

**WALK-BEHIND  
SNOWTHROWERS**

**555  
755E**



**OPERATOR'S  
MANUAL**

**This manual covers the following Mfg. Nos.:**

555: **Mfg. No. 1690900**  
**Mfg. No. 1691011**  
**Mfg. No. 1691411**  
**Mfg. No. 1691415**

755: **Mfg. No. 1691181**  
**Mfg. No. 1691413**  
**Mfg. No. 1691414**

## Contents

---

<b>SERVICE PARTS</b> .....	ii	<b>SERVICE</b> .....	14
<b>IDENTIFICATION &amp; ACCESSORIES</b> .....	1	TROUBLESHOOTING CHART .....	14
<b>SAFETY RULES</b> .....	2	DRIVE BELT ADJUSTMENT .....	16
<b>DECALS</b> .....	3	SHIFT CONTROL ADJUSTMENT .....	17
<b>OPERATION</b> .....	7	CARBURETOR ADJUSTMENT .....	18
CONTROLS .....	7	SPARK PLUG ADJUSTMENT .....	18
PRE-USE CHECK OF CONTROLS .....	8	DRIVE BELT REPLACEMENT .....	18
BEFORE STARTING ENGINE .....	8	ROLLER CHAIN REPLACEMENT .....	20
TO START ENGINE .....	8	SHEAR PIN REPLACEMENT .....	21
SNOWTHROWER OPERATION .....	10	TRANSMISSION REPLACEMENT .....	21
AFTER EACH USE .....	10	WHEEL AXLE BEARING REPLACEMENT .....	21
<b>NORMAL CARE</b> .....	11	(Early Models)	
ENGINE STORAGE .....	11	AUGER SHAFT BEARING REPLACEMENT .....	22
STARTING AFTER STORAGE .....	11	(Early Models)	
LUBRICATION .....	12	WHEEL AXLE BEARING REPLACEMENT .....	23
TIRE PRESSURE .....	12	(Later Models)	
LUBRICATION CHART .....	13	AUGER SHAFT BEARING REPLACEMENT .....	23
		(Later Models)	
		<b>SPECIFICATIONS</b> .....	24
		<b>PARTS MANUAL AVAILABLE</b> .....	25

## Service Parts

Listed below are part numbers for the more common maintenance items. Use the order form at the back of the manual to order a complete, illustrated manual. Use only Genuine Simplicity Replacement Parts to assure optimum performance and safety.

<u>DESCRIPTION</u>	<u>PART NUMBER</u>	<u>DESCRIPTION</u>	<u>PART NUMBER</u>
<b><u>MAINTENANCE ITEMS</u></b>			
<b>Simplicity Brand SAE 5W30-Cold Weather Engine Oil (case of 12 qts.)</b> <i>Use for engine and all lubrication - see page 13.</i>	<b>1685576</b> (case of 12 qts. - see your dealer for individual quarts)	<b>Gas Can, 2½ Gal.</b>	<b>1685555</b>
<b>Touch-Up Paint</b>		<b>Gas Can, 5¼ Gal.</b>	<b>1685556</b>
Orange Spray Paint, 13 Oz. Can	<b>1685558</b>	<b>Drift Cutter Kit</b>	<b>1685189</b>
Powder Orange Spray Paint, 13 Oz. Can	<b>1685589</b>	<b>"Do-It-Yourself" Repair Manual</b>	<b>1678586</b>
Powder Orange Spray Paint, 13 Oz. Can, Case of 12	<b>1685590</b>	<b><u>REPLACEMENT PARTS</u></b>	
Powder Orange Paint, 1 Qt.	<b>1685593</b>	<b>Knob, Chute Control</b>	<b>1668190</b>
Deep Orange Spray Paint, 13 Oz. Can	<b>1685611</b>	<b>Pushnut (for Chute Control Knob)</b>	<b>1960093</b>
Deep Orange Spray Paint, 13 Oz. Can, Case of 12	<b>1685614</b>	<b>Shear Pin, Auger</b>	<b>1668344</b>
Deep Orange Paint, 1 Qt.	<b>1685612</b>	<b>Cotter Pin (for Shear Pin)</b>	<b>1918447</b>
White Spray Paint, 13 Oz. Can	<b>103049</b>	<b>Keys, Ignition</b>	<b>122203</b>
Touch-Up Daubers		<b>Belt, Auger Drive - All Models</b>	<b>1674312</b>
Regular Orange	<b>1685562</b>	<b>Belt, Traction Drive - 5 HP</b>	<b>1674308</b>
Powder Orange	<b>1685593</b>	<b>Belt, Traction Drive - 7 HP</b>	<b>1678600</b>
Deep Orange	<b>1685613</b>	<b>Handle Grip</b>	<b>1676954</b>
<i>(6 orange &amp; 6 white - see your dealer for individual daubers.)</i>		<b>Skid Shoes (Set of 2)</b>	<b>1685501</b>
<b>Grease Gun Kit</b>	<b>1685510</b>	<b>Pneumatic Tire Sealant - Prevent Flats</b> 1 - 11 Oz. Tube <b>1685523</b> 6 - 11 Oz. Tubes <b>1685525</b>	
<b>8 Oz. Lithium Grease Tube for above</b>	<b>103077</b>	<b>USE ONLY GENUINE SIMPLICITY REPLACEMENT PARTS</b> <b>Available through your local authorized Simplicity dealer.</b>	

## Identification & Accessories

Record your model and serial numbers here for reference.  
The snowthrower I.D. tag is located on rear of frame.

\_\_\_\_\_  
Snowthrower I.D. Number

\_\_\_\_\_  
Snowthrower Serial Number

\_\_\_\_\_  
Engine Model and Type

\_\_\_\_\_  
Engine Serial Number

(See engine Owner's Manual for location of serial number).

See your dealer to purchase any of the following accessories for your snowthrower.

### Tire Chains

Increase traction on snowy surfaces (use with caution to avoid marking surfaces). For use with pneumatic tires.

### Electric Starter Kit (120V AC):

Offers operator the convenience of electric starting.



### WARNING

This unit is a "two-stage" snowthrower. The first stage is the auger, which feeds the snow back into the impeller housing. The second stage is the impeller which throws the snow out the discharge chute. If bodily contact is made with the auger or impeller when they are rotating, severe personal injury will occur. To avoid injury, keep others and yourself away from the auger and the discharge chute whenever the engine is running. See Safety Rules on the following pages.



### WARNING

To avoid serious injury do not put your hands into the auger housing or discharge chute. If auger stalls or chute plugs, use the following procedure to remove objects or clear the chute.

1. Release both drive levers.
2. Shut off the engine.
3. Wait for moving parts to stop.
4. Use a narrow board to remove foreign objects and clear the chute. Never put your hands into the auger or discharge chute, because tension buildup due to plugging could cause parts to rotate upon clearing.

## Safety Rules



*Read these safety rules and follow them closely. Failure to obey these rules can result in loss of control of machine, severe personal injury to yourself or bystanders, or damage to property or equipment affecting safety. The triangle  in the text signifies important cautions or warnings which must be followed.*

### TRAINING

- Read the operating and service instruction in this manual carefully. Be thoroughly familiar with the controls and the proper use of the equipment. Know how to stop the unit and disengage the controls quickly.
- Never allow children to operate the equipment. Never allow adults to operate the equipment without proper instruction.
- Keep the area of operation clear of all persons, particularly small children, and pets.
- Exercise caution to avoid slipping or falling, especially when operating in reverse.

### PREPARATION

- Thoroughly inspect the area where the equipment is to be used and remove all doormats, sleds, boards, wires, and other foreign objects.
- Disengage all clutches and shift into neutral before starting the engine (motor).
- Do not operate the equipment without wearing adequate winter outer garments. Wear footwear that will improve footing on slippery surfaces.

- Handle fuel with care; it is highly flammable.
  - a. Use an approved fuel container.
  - b. Never add fuel to a running engine or hot engine.
  - c. Fill fuel tank outdoors with extreme care. Never fill fuel tank indoors.
  - d. Replace gasoline cap securely and wipe up spilled fuel.
- Use extension cords and receptacles as specified by the manufacturer for all units with electric drive motors or electric starting motors.
- Adjust the collector housing height to clear gravel or crushed rock surface.
- Never attempt to make any adjustments while the engine (motor) is running (except when specifically recommended by manufacturer).
- Let engine (motor) and machine adjust to outdoor temperatures before starting to clear snow.
- Always wear safety glasses or eye shields during operation or while performing an adjustment or repair to protect eyes from foreign objects that may be thrown from the machine.

**OPERATION**

- Do not put hands or feet near or under rotating parts. Keep clear of the discharge opening at all times.
- Exercise extreme caution when operating on or crossing gravel drives, walks, or roads. Stay alert for hidden hazards or traffic.
- After striking a foreign object, stop the engine (motor), remove the wire from the spark plug, thoroughly inspect the snowthrower for any damage, and repair the damage before restarting and operating the snowthrower.
- If the unit should start to vibrate abnormally, stop the engine (motor) and check immediately for the cause. Vibration is generally a warning of trouble.
- Stop the engine (motor) whenever you leave the operating position, before unclogging the collector/impeller housing or discharge guide, and when making any repairs, adjustments, or inspections.
- When cleaning, repairing, or inspecting, make certain the collector/impeller and all moving parts have stopped. Disconnect the spark plug wire and keep the wire away from the plug to prevent accidental starting.
- Do not run the engine indoors, except when starting the engine and for transporting the snowthrower in or out of the building. Open the outside doors; exhaust fumes are dangerous.

- Do not clear snow across the face of slopes. Exercise extreme caution when changing direction on slopes. Do not attempt to clear steep slopes.
- Never operate the snowthrower without proper guards, plates, or other safety protective devices in place.
- Never operate the snowthrower near glass enclosures, automobiles, window wells, drop-offs, and the like without proper adjustment of the snow discharge angle. Keep children and pets away.
- Do not overload the machine capacity by attempting to clear snow at too fast a rate.
- Never operate the machine at high transport speeds on slippery surfaces. Look behind and use care when backing.
- Never direct discharge at bystanders or allow anyone in front of unit.
- Disengage power to the collector/impeller when the snowthrower is transported or not in use.
- Use only attachments and accessories approved by the manufacturer of the snowthrower (such as wheel weights, counterweights, cabs, and the like).
- Never operate the snowthrower without good visibility or light. Always be sure of your footing, and keep a firm hold on the handles. Walk; never run.

**MAINTENANCE & STORAGE**

- Check shear pins and other fasteners at frequent intervals

## *Safety Rules*

---

for proper tightness to be sure the equipment is in safe working condition.

- Never store the machine with fuel in the fuel tank inside a building where ignition sources are present such as hot water and space heaters, clothes dryers, and the like. Allow the engine to cool before storing in any enclosure.
- Always refer to operator's guide instructions for important details if the snowthrower is to be stored for an extended period.
- Maintain or replace safety and instruction labels, as necessary.
- Run the machine a few minutes after throwing snow to prevent freeze-up of the collector/impeller.



## Safety Decals

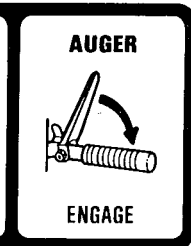
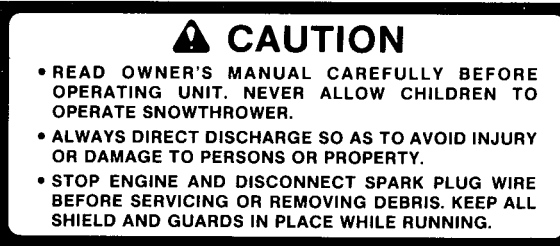
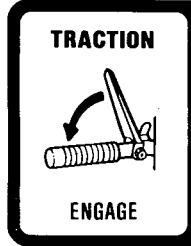
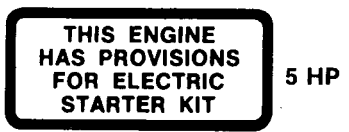
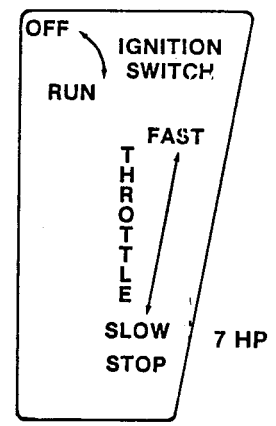
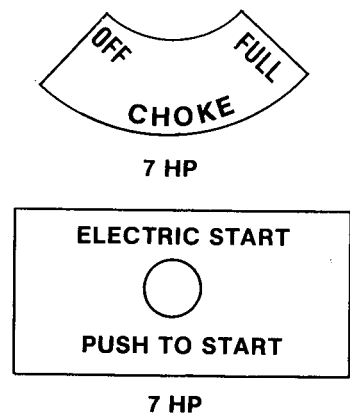
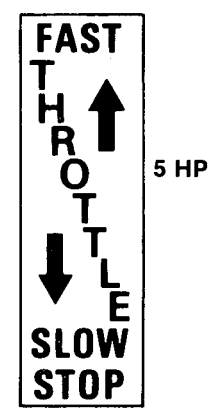
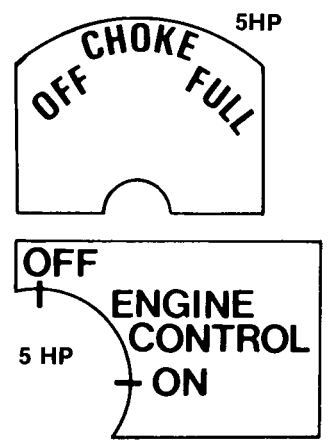

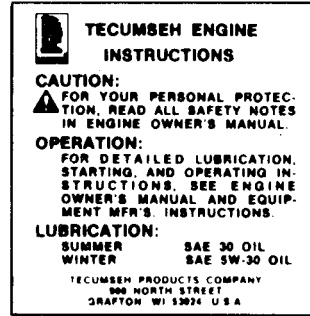
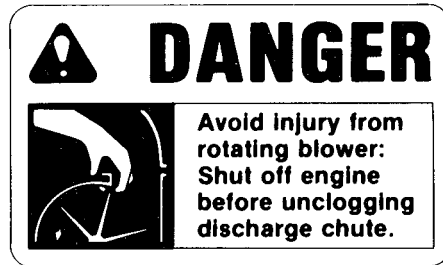

**Safety Decals**

Safety warning signs are placed at strategic locations on the snowthrower as a constant reminder to the operator of the most important safety precautions. All Warning, Caution, and instructional messages on your snowthrower should be carefully read and obeyed.

If any of these signs are lost or damaged, replace them at once. They can be purchased from your dealer.

## Operation

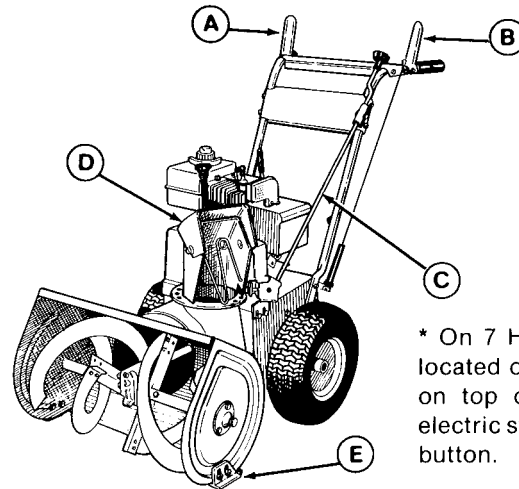

\* On 7 HP model, choke is located on top. Also located on top of 7 HP engine is electric start plug and starter button.

ITEM	NAME	FUNCTION
A	Auger Control Clutch Lever	Engages auger/impeller when depressed; disengages when released.
B	Drive Control Clutch Lever	Engages drive to wheels when depressed; disengages when released.
C	Chute Control Rod	Controls direction snow is thrown.
D	Discharge Chute Deflector	Controls angle snow is thrown.

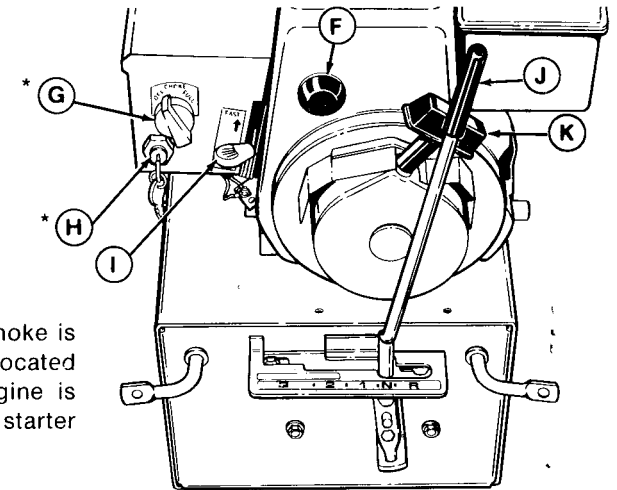

ITEM	NAME	FUNCTION
E	Skid Shoe	Controls height of scraper bar.
F	Primer Button	Primes carburetor.
G	Choke	Enriches fuel supply.
H	Ignition Switch	Allows starting and stopping of engine.
I	Throttle Lever	Controls engine speed.
J	Shift Lever	Controls ground speed and direction.
K	Starter Handle	Used to start engine.

Figure 1. Controls



**WARNING**

**Before leaving the operator's position for any reason, such as to make an adjustment or clear the chute, stop the engine and remove the key. Disconnect the spark plug wire and secure away from plug to prevent accidental starting.**

**PRE-USE CHECK OF CONTROLS**

1. Check discharge control rod for proper function. Check to make sure sprocket teeth on lower chute control rod fully engage holes in flange around bottom of discharge chute. The bracket that holds lower chute control rod is slotted and can be moved up or down to obtain full engagement of sprocket teeth. Make sure upper and lower chute control rods are properly assembled.
2. Check shift lever for proper position (See Drive Control Adjustment paragraph in Service section of this manual.)
3. Check drive control clutch lever, auger control clutch lever and discharge chute deflector for proper operation (see Drive Belt Adjustment paragraph in Service section of this manual.)
4. After servicing engine and before beginning snow removal, check controls again with engine running.
5. Check skid height if necessary for area to be cleared (see Skid Height Adjustment paragraph in Service section of this manual).

6. Check to make sure spark plug wire is attached to plug and plug is tightened securely into engine. If torque wrench is available, torque to 15 foot pounds.

**BEFORE STARTING ENGINE**

1. Check engine oil level, add oil as needed.

**NOTE**

New engine is supplied with NO OIL. Be sure oil has been added (see Engine Manual for proper procedure.) Ask your dealer for recommended cold weather engine oil.



**WARNING**

**Gasoline is highly flammable and must be handled with care. Never fill the tank when the engine is hot or running. Always move the unit outdoors to fill the tank. Keep snowthrower and gasoline away from open flame or spark.**

2. Fill gas tank with clean, fresh, lead-free grade automotive gasoline. Low-lead or regular grade gasoline is an acceptable substitute.

**TO START ENGINE**

**NOTE**

Also read the starting instructions in your engine Owner's Manual.

1. Move shift lever (J, figure 1) to NEUTRAL position.

2. Rotate ignition switch key (H, figure 1) clockwise to ON or RUN position.
3. Move throttle control lever (I, figure 1) to FAST position.
4. Move choke lever (G, figure 1) to FULL CHOKE position. Do not choke a warm engine.
5. Push primer button (F, figure 1) two times. Do not prime a warm engine.



**WARNING**

Never run engine indoors or in enclosed, poorly ventilated areas. Engine exhaust contains CARBON MONOXIDE, an ODORLESS, DEADLY GAS.

Keep hands, feet, hair and loose clothing away from any moving parts on engine and snowthrower.

WARNING - Temperature of muffler and nearby areas may exceed 150° F. Avoid these areas.

6. Pull starter handle (K, figure 1) rapidly or push starter button if equipped. Do not allow starter handle to snap back but rewind slowly while keeping a firm hold of starter handle.
7. As engine warms up and begins to operate evenly, move choke lever slowly to OFF position. If engine falters, return to ½ choke until it runs smoothly, then move to OFF choke position.

**NOTE:**

Allow the engine to warm up for a few minutes as the engine will not develop full power until it reaches operating temperature.

8. Run engine at or near top speed. To help prevent possible freeze-up of rewind starter, proceed as follows after each snow blowing job:
  - a. With engine running, pull starter rope hard with a continuous full arm stroke three or four times. Pulling of starter rope will produce a loud clattering sound. This is not harmful to the engine or starter.
9. To stop forward motion, release drive control clutch lever (B, figure 1) on left handle. To stop engine, move throttle control lever to STOP position and move ignition switch key to OFF position. To help prevent possible freeze-up of engine controls, proceed as follows after each snow blowing job:
  - a. With engine not running, wipe all snow and moisture from carburetor cover in area of control levers. Also move control levers backward and forward several times.

**Important:** After each use of the snowthrower, stop the engine, remove the ignition key, remove all accumulated snow from the snowthrower and wipe clean. Store the snowthrower in a protected area.

## SNOWTHROWER OPERATION

The most effective use of the snowthrower will be established by experience, taking into consideration the terrain, wind conditions and the depth and weight of the snow. It is the wind conditions and building location which will determine the direction of the discharge chute. Since the wind will tend to blow the discharged snow back into the cleared area, it will be necessary to change the chute direction to offset this condition.

### NOTE

Do not throw snow towards a building as hidden objects could be thrown with sufficient force to cause damage.

To engage the self-propelling drive mechanism, proceed as follows:

1. Start the engine as described in paragraph To Start Engine.
2. Using the chute control rod (C, figure 1), position the discharge chute so as to discharge the snow with the wind.
3. Set the discharge deflector (D, figure 1) for desired angle.
4. Select proper speed for snow conditions as outlined below and set shift lever to desired position.
  - a. Number 1 position is for extra deep, wet heavy snow.
  - b. Number 2 position is for deep, wet heavy snow. Experience will help make the choice between positions 1 and 2.
  - c. Number 3 position is for light fluffy snow and for transporting snowthrower over bare or cleared areas.

5. Press the auger clutch lever on right hand grip to begin auger rotation.
6. Press the drive clutch lever, on left hand grip, and snowthrower will begin forward (or backward, depending on drive control lever position) motion.
7. To disengage the drive mechanism: Release both clutch levers. Set the shift lever to the NEUTRAL position.
8. To move snowthrower backwards: Place shift lever in REVERSE position and press the drive control clutch lever on left hand grip. To stop backward motion: Release pressure from drive control clutch lever. Return shift lever to NEUTRAL position.

### NOTE

Adjustment of V-belt may be necessary after a normal break-in period of 2 to 4 hours of use. See Drive Belt Adjustment paragraph in Service section of this manual.

### AFTER EACH USE.

1. See Engine Manual for proper care of engine between uses.
2. Turn ignition off and remove key to prevent unauthorized use.
3. Clean snow and ice from snowthrower.
4. If snowthrower is kept in a cold storage area, fill gas tank to prevent condensation.

## Normal Care

The snowthrower should be immediately prepared for storage at the end of the season or if the snowthrower is to be unused for 30 days or more.



### WARNING

**Never store engine with fuel in tank indoors or in enclosed, poorly ventilated enclosures, where fuel fumes may reach an open flame, spark or pilot light as on a furnace, water heater, clothes dryer, etc.**

**Handle gasoline carefully. It is highly flammable and careless use could result in serious fire damage to your person and/or property.**

**Drain fuel into approved container outdoors, away from open flame.**

### ENGINE STORAGE

Gasoline, if permitted to stand unused for extended periods (30 days or more), may develop gummy deposits which can adversely affect the engine carburetor and cause engine malfunction. To avoid this condition, add a gasoline stabilizer (available from your dealer) or proceed as follows:

1. Prior to shutdown for 30 days or more, and for seasonal storage, drain gasoline from fuel tank. It is not necessary to drain tank if stabilizer is used.

2. Run engine until fuel tank is empty and engine stops due to lack of fuel.
3. Remove fuel line at tank or carburetor and drain any remaining gasoline from system.
4. Remove spark plug and pour one (1) ounce of engine oil through spark plug hole into cylinder. Crank engine several times to distribute oil. Reinstall spark plug.
5. Clean the snowthrower thoroughly; remove all debris and wipe the snowthrower dry. Coat all exposed bare metal parts with a good quality paint (available from your dealer) or a light film of grease, oil or automotive wax.
6. Inspect the snowthrower for worn or damaged parts; tighten all loose hardware.
7. Oil all points described in "Lubrication" section.
8. Store snowthrower in wheels down, operating position. If stored in any other position, oil from crankcase could enter cylinder head, causing a service problem. Store in protected area and cover for additional protection.

**Important:** A yearly checkup or tuneup by your dealer is a good way of insuring that your snowthrower will provide maximum performance for the next season.

### STARTING AFTER STORAGE

1. Remove spark plug and wipe dry. Crank engine a few times to blow excess oil out of plug hole. Reinstall plug.
2. Fill gas tank with fresh gasoline (unless a gasoline stabilizer was used).
3. Check to make sure engine is clean.
4. Start engine outdoors. Do not run engine at high speeds immediately after starting.
5. Check operation of controls. Lubricate as instructed in Lubrication Chart on page 13.

### LUBRICATION

For lubrication points, frequency of lubrication and type of lubricant, see Lubricant Chart on page 13.

1. Check crankcase oil level before starting engine and after each 5 hours of continuous use. Add oil as required. Change crankcase oil after first 2 hours of operation and every 25 hours of operation thereafter, or at beginning of each season. To drain oil, proceed as follows:

- a. Remove oil fillcap/dipstick.
  - b. Remove oil drain cap.
  - c. Tip snowthrower toward oil drain cap and drain oil into a suitable container. Oil will drain more freely when warm.
  - d. Reinstall oil drain cap and tighten securely and fill crankcase to proper level shown on dipstick (approximately 1¼ pints). Reinstall oil fill cap/dipstick.
2. The transmission and auger gear case have been factory lubricated for life. If for some reason lubricant should leak out, have transmission or auger gear case checked by your dealer. To check level, remove the check plug (figure 2). The fluid should be level with hole. If not, add Simplicity worm gear oil (available from your dealer).

### TIRE PRESSURE

Snowthrower tires, whether pneumatic or Snow Hog, should be inflated to 20 psi (136 kPa).



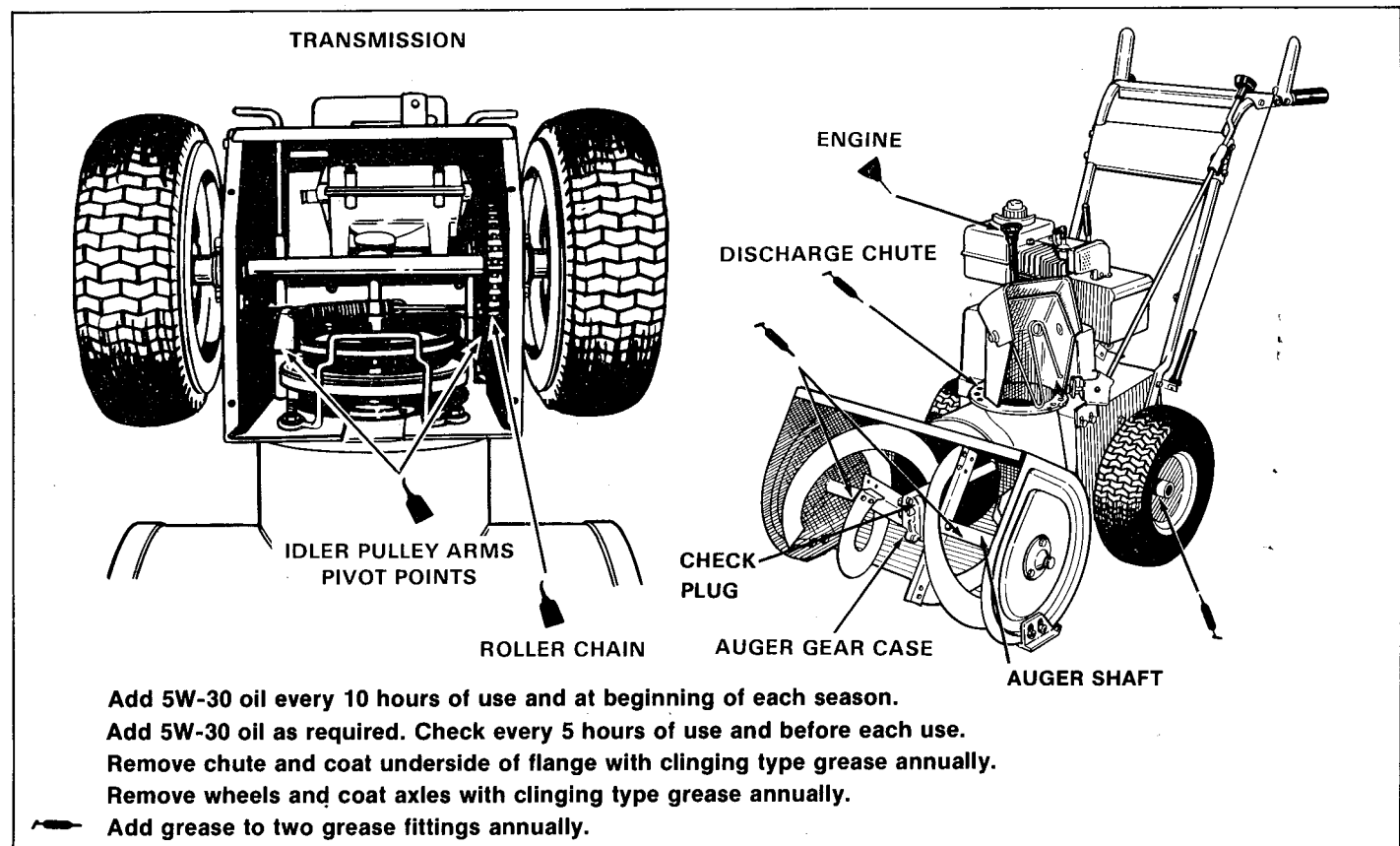

Figure 2. Lubrication Chart



## WARNING

Always disconnect the spark plug wire and tie back away from spark plug before making any repairs or adjustments.

## TROUBLESHOOTING

Locate the problem in Troubleshooting Chart. Check the possible causes. Correct any problems and try to operate the snowthrower again to see if you have eliminated the problem.

This section provides troubleshooting and service instructions. For problems not covered here, contact your dealer.

## TROUBLESHOOTING CHART

PROBLEM	CAUSE	REMEDY
Difficult starting; Engine runs erratic	Defective spark plug.	Replace defective plug.
	Blocked fuel line or empty gas tank	Clean fuel line; check fuel supply.
	Review paragraph To Start Engine	
Engine stalls; Loss of power; Engine runs erratic	Engine running on CHOKE	Set choke lever to RUN position.
	Obstruction in auger housing	Remove obstruction; clean auger housing. Refer to Warning on page 1.
	Water in fuel system	Remove carburetor bowl to drain fuel. Refill with fresh fuel. CAUTION: Do not remove carburetor bowl when engine is hot.
Excessive vibration	Loose parts; Damaged auger	Stop engine immediately; tighten all bolts and make all necessary repairs. If vibration continues, have the snowthrower serviced by your dealer.

PROBLEM	CAUSE	REMEDY
Snowthrower fails to propel itself	Drive belt loose or damaged	Adjust or replace drive belt. Refer to Drive Belt Replacement paragraph.
	Drive roller chain damaged	Replace roller chain. Refer to Roller Chain Replacement paragraph.
	Unit (wheel) drive belt loose or damaged	Adjust unit drive belt; replace if damaged. Refer to Drive Belt Adjustment paragraph or Drive Belt Replacement paragraph.
	Transmission trouble	Have transmission checked by your dealer.
Snowthrower fails to discharge snow	Auger drive belt loose or damaged	Adjust auger drive belt; replace if damaged. Refer to Drive Belt Adjustment paragraph or Drive Belt Replacement paragraph.
	Shear pin broken	Replace shear pin. Refer to Shear Pin Replacement paragraph.
	Discharge chute clogged	Clean discharge chute and inside of auger housing. Refer to Warning on page 1.
	Foreign object lodged in auger	Remove object from auger. Refer to Warning on page 1.
	Auger gear case trouble	Check auger gear case for broken or bound parts. Have gear case checked by your dealer.
	Transmission trouble	Have transmission checked by your dealer.
Improper shifting	Shift control lever out of adjustment	Make adjustment as instructed in Shift Control Adjustment paragraph.

**WARNING**

Always disconnect the spark plug wire and tie back away from plug before making any repairs.

**DRIVE BELT ADJUSTMENT**

This snowthrower is equipped with two drive belts located just in front of engine under belt cover (figure 3). Figure 4 shows both belts and idler pulleys. Belt nearest engine is unit drive (wheels) belt. Other belt (farthest from engine) is auger/impeller drive belt.

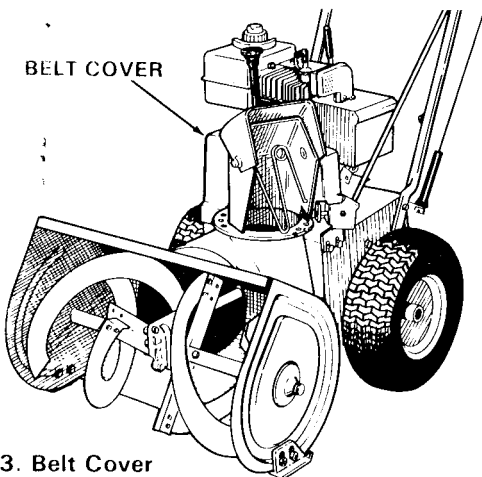
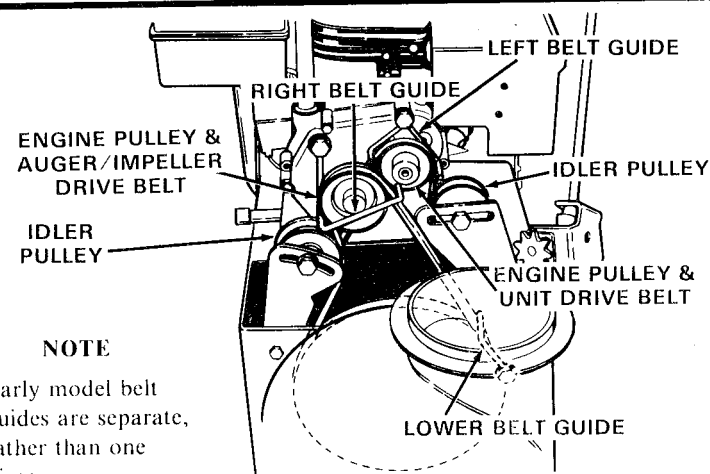

Figure 3. Belt Cover

If adjustment becomes necessary due to wear or stretch of either belt:

1. Disconnect spark plug wire, tie back away from plug and remove belt cover (figure 3).
2. Loosen locknut on idler pulley and move idler pulley 1/4 inch toward belt. Determine if additional adjustment is needed by trying unit.
3. Check belt guides (figure 4) for proper clearances as follows. Belt guides on 7 HP models are slightly different than shown, but adjustment is the same.
  - a. Have someone hold auger and auger/impeller clutch levers (on upper handle) down against hand grips.
  - b. Right belt guide (figure 4) should be adjusted to a position where it clears auger/impeller drive belt by not less than 1/16 inch or more than 1/8 inch. The clearance should be even on both sides of pulley. Make sure that guide does not touch hub on unit drive engine pulley and that screw holding belt guide is tightened securely.
  - c. Left belt guide on unit drive belt and engine pulley should be adjusted to clear belt by not less than 1/16 inch or more than 1/8 inch. The clearance should be even on both sides.
  - d. Adjust lower belt stop to not less than 1/16 inch or more than 1/8 inch from auger/impeller drive belt.
  - e. Reconnect spark plug wire.

**NOTE**

Early model belt guides are separate, rather than one piece.

**Figure 4. Drive Belt Adjustment**

**SHIFT CONTROL ADJUSTMENT**

Adjustment to shift control lever will be necessary if:

1. Snowthrower is not in neutral when shift lever is in NEUTRAL position.
2. Reverse position cannot be fully reached.
3. Third (3rd) gear cannot be fully reached. If any of these three conditions exists, adjust as follows:
  - a. Disconnect spark plug wire.

- b. Locate neutral position of shift lever by moving unit back and forth with traction lever engaged. Unit will move easily in neutral.
- c. Leave shift lever in position where neutral was obtained.
- d. Loosen screws in shift control bracket (figure 5) rear of snowthrower.
- e. Slide shift control bracket left or right until shift lever is in proper neutral position. Tighten screws in drive control bracket.

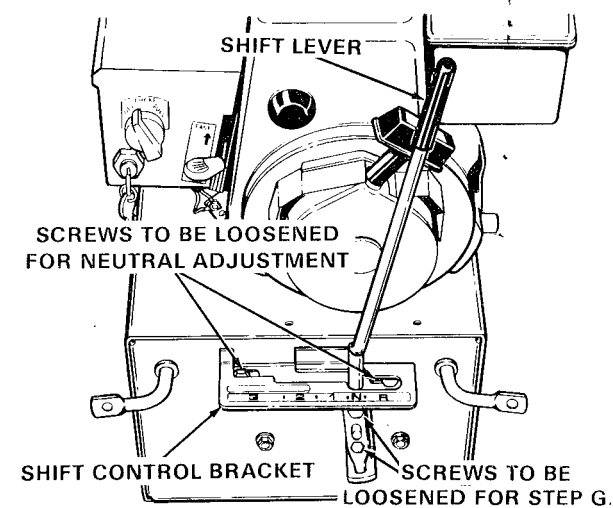

**Figure 5. Shift Control Adjustment**

- f. Check adjustment by moving lever to each position. Be sure to check to see that NEUTRAL is properly reached from both directions (from reverse and from forward gear).
- g. Check shift lever movement from reverse to 3rd and make sure lever does not contact handles. To adjust, loosen two screws, move lever slightly, then tighten the screws and check again. (Not adjustable for Mfg. No. 1690900).
- h. Reconnect spark plug wire.

**CARBURETOR ADJUSTMENT**

See Engine Owner's Manual for proper procedure.

**SPARK PLUG ADJUSTMENT**

See Engine Owner's Manual for proper procedure.

Before reinstalling spark plug, coat threads lightly with graphite grease to insure easy removal. If torque wrench is available, torque plug to 15 foot pounds.

**DRIVE BELT REPLACEMENT**

The drive belts on this snowthrower are of special construction and should be replaced with original equipment belts available from your dealer.

**To replace unit drive belt (belt nearest engine):**

- 1. Remove gas from fuel tank and run engine until it dies from lack of fuel.
- 2. Disconnect spark plug wire, tie back away from plug and remove belt cover (figure 3).

- 3. Loosen screw holding left belt guide (figure 6).
- 4. Remove belt from pulley (figure 6). Pivot belt guide as necessary.
- 5. Stand snowthrower up on auger end.

**CAUTION**  
A block (approximately 4 inches high) will have to be placed under top front edge of auger housing or snowthrower will not stand on end.

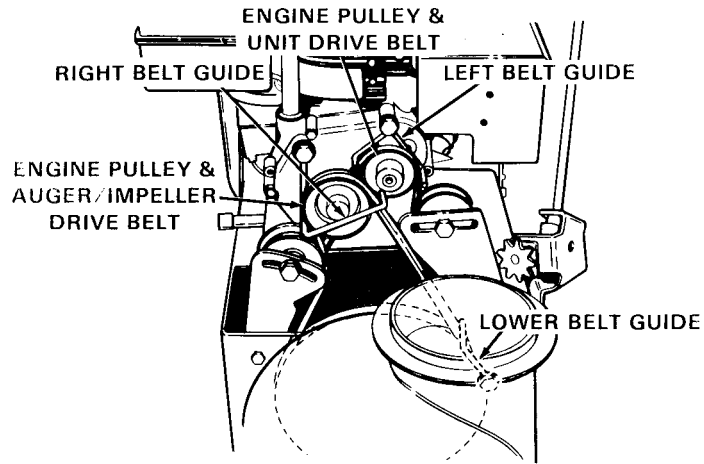

Figure 6. Drive Belt Replacement

6. Loosen nuts holding lower belt guard (figure 7) and slide guard away from belt.
7. Remove belt between large drive pulleys.
8. Install new belt in reverse order.
9. Slide belt guard back to within 1/16 inch of large drive pulley and tighten nuts.

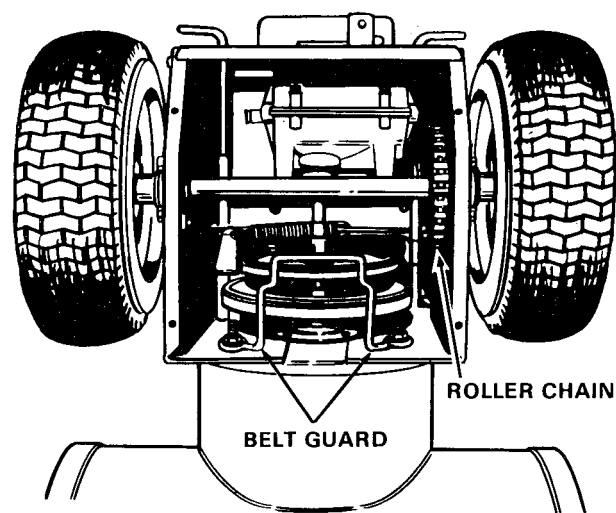

Figure 7. Drive Belt Replacement

10. Return snowthrower to operating position.
11. Place new belt onto engine pulley.
12. Adjust belt guides as instructed in step 3 of Drive Belt Adjustment.
13. Adjust belt as instructed in Drive Belt Adjustment.
14. Reinstall belt cover, reconnect spark plug wire and refill fuel tank.

**To replace auger/impeller drive belt (belt farthest from engine):**

1. Remove gas from fuel tank and run engine until it dies from lack of fuel.
2. Disconnect spark plug wire, tie wire away from plug and remove belt cover (figure 3).
3. Loosen screw holding right belt guide (figure 6).
4. Remove belt from engine pulley. Pivot belt guide as necessary.
5. Stand snowthrower up on auger.

**CAUTION**

A block (approximately 4 inches high) will have to be placed under top front edge of auger housing or snowthrower will not stand on end.

6. Remove the bottom pan.

7. Loosen nuts holding lower belt guard (figure 7) and slide guard away from belt.
8. Remove belt between large pulleys.
9. Install new belt in reverse order.
10. Slide belt guard back to within 1/16 inch of large drive pulley and tighten nuts.
11. Return snowthrower to operating position.
12. Place new belt onto engine pulley.
13. Adjust belt guide as instructed in step 3 of Drive Belt Adjustment.
14. Adjust belt as instructed in Drive Belt Adjustment.
15. Reinstall belt cover, pan, reconnect spark plug wire and refill fuel tank.

### ROLLER CHAIN REPLACEMENT

1. Remove gas from fuel tank and run engine until it dies from lack of fuel. Disconnect spark plug wire and tie away from plug.
2. Stand snowthrower up on auger end.

#### CAUTION

A block (approximately 4 inches high) will have to be placed under top front edge of auger housing or snowthrower will not stand on end.

3. Locate master link (figure 8) in chain to be replaced.
4. Check position of open end keeper link (figure 8) so that replacement link can be installed in the same manner. Open end of keeper link must be in trailing position when chain is operating in direction required for forward motion of snowthrower.
5. Remove master link and remove chain.
6. Install new chain in reverse order of removal.
7. Return snowthrower to operating position.
8. Reconnect spark plug wire and refill fuel tank.

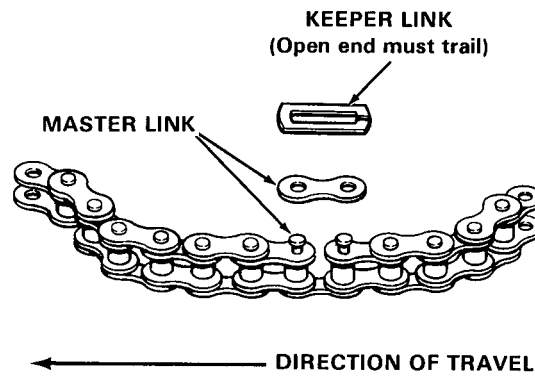

Figure 8. Roller Chain Replacement



**SHEAR PIN REPLACEMENT****NOTE**

Mfg. no. 1690900 has bolts rather than pins.

The auger assembly is made up of a right and left auger. Each is secured with a shear pin (figure 9). These pins are designed to break (to prevent damage to snowthrower) if an object becomes lodged in the auger. Two shear pins have been furnished with your snowthrower. If additional pins are required, order genuine replacement pins. Use of a harder pin will destroy the protection provided by this special pin. To replace a broken shear pin proceed as follows:

1. Disconnect spark plug wire, tie wire away from plug and

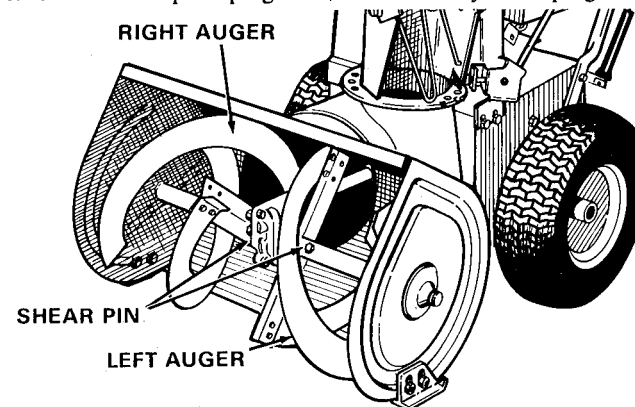

Figure 9. Shear Pin Replacement

remove the parts of the broken pin.

2. Align the hole in the auger with the hole in the auger shaft. Install new shear pin and coter pin.
3. Reconnect spark plug wire.

**TRANSMISSION REPLACEMENT**

The replacement of the transmission on this snowthrower is a major service operation and should be done by your dealer.

**WHEEL AXLE BEARING REPLACEMENT  
(Mfg. No. 1691181 and Below)**

After approximately 100 hours (about 5 years) of use or if drive chain jumps off sprockets, bearing on wheel axle may need to be replaced. To replace bearings:

1. Disconnect spark plug wire and tie back away from spark plug.
2. Place a block (just enough to raise wheels off ground) under rear of snowthrower.
3. Remove pin (figure 10) that secures wheel to axle and remove (mfg. no. 1690900 has bolt).
4. Remove spacer and washer that is behind wheel and remove three nuts that secure bearing to rear frame assembly.
5. Remove old bearing from axle shaft and install new bearing. Reinstall removed parts in reverse order of removal.

**NOTE**

Hold down on wheel axle while tightening bearing screws to tension roller chain.

6. Repeat steps 3 through 5 on opposite side. Remove block from under snowthrower and reconnect spark plug wire.

**AUGER SHAFT BEARING REPLACEMENT  
(Mfg. No. 1691181 and Below)**

If auger shaft bearings (at center of auger housing ends) ever need to be replaced, proceed as follows:

1. Disconnect spark plug wire and tie back away from plug.
2. Remove three screws (figure 10) that secure bearing to outside of auger housing end.
3. Install new bearing and secure with removed screws, washers and locknuts.

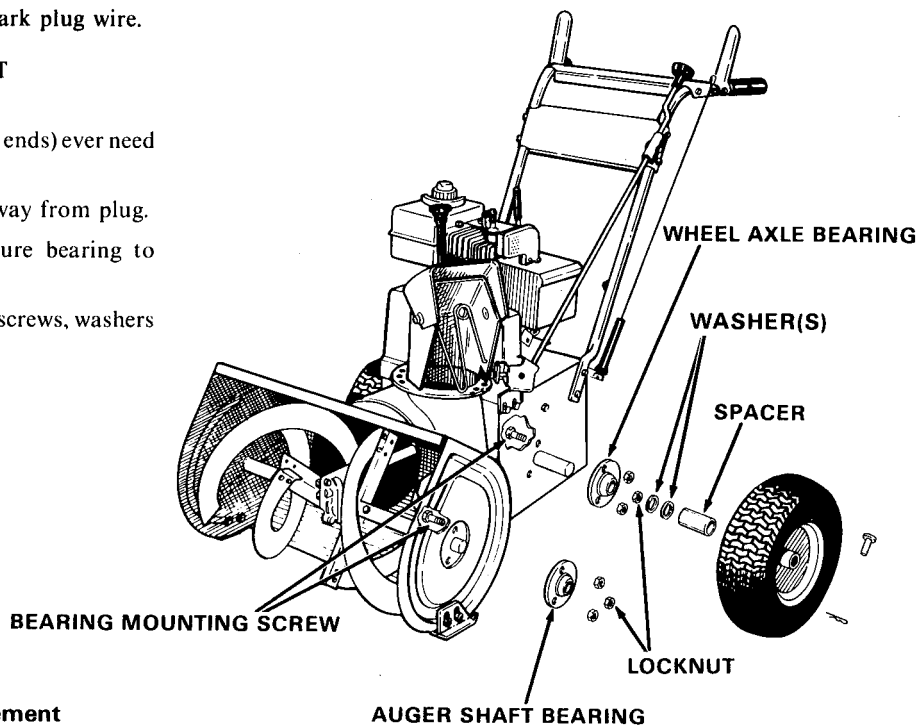

Figure 10. Wheel & Auger Bearing Replacement

### WHEEL AXLE BEARING REPLACEMENT (Mfg. Nos. 1691411 and Above)

After approximately 100 hours (about 5 years) of use or if drive chain jumps off sprockets, bearing on wheel axle may need to be replaced. To replace bearings:

1. Disconnect spark plug wire and tie back away from spark plug.
2. Place a block (just enough to raise wheels off ground) under rear of snowthrower.
3. Remove ring pin that secures wheel and remove from axle.

#### CAUTION

Note the number and placement of washers used between wheel and long spacer, or between spacer and bearing. Snowthrowers before serial number 3890 may have an uneven number of washers from side to side (example: two washers on left shaft, one washer on right shaft). On serial number 3890 and after, an even number of washers must be used on each side of shaft.

4. Slide off the washers and long spacer. Then, pull bearing out of housing opening and off the shaft.
5. Install new bearing by aligning "flats" with hole.
6. Install parts in original position. Refer to figure 11.

### AUGER SHAFT BEARING REPLACEMENT (Mfg. Nos. 1691411 and Above)

If auger shaft bearings (at ends of auger shaft) ever need to be replaced, proceed as follows:

1. Pry off the E-ring (figure 11).
2. Remove the washers, then pull bearing out of housing and off shaft.
3. Install new bearing by aligning "flat." Install washers on the shaft. Install E-ring securely in groove.

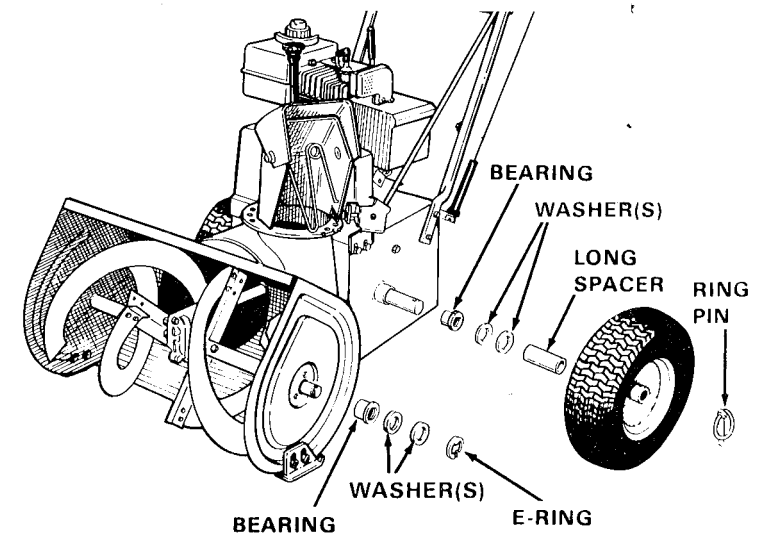

Figure 11. Wheel & Auger Bearing Replacement

# Specifications

---

## ENGINE

**Make:** Tecumseh

**Cylinders:** 1

**Cycles:** 4

**Crankshaft:** Horizontal

**Model No.:** See engine I.D. plate

**Type:** See engine I.D. plate

**5 HP - Bore & Stroke:** 2 - 13/16 In. (71.44 mm) x 1 - 15/16 In.  
(49.23 mm)

**5 HP - Displacement:** 12.04 Cu. In. (197.34 cc)

**7 HP - Bore & Stroke:** 2-3/4 In. (69.86 mm) x 2-17/32 In.  
(64.31 mm)

**7 HP - Displacement:** 15.04 Cu. In. (246.5 cc)

**Ignition:** Magneto with Key Switch

**Governor:** Mechanical

**Choke:** Manual

**Lubrication:** Splash System

**Oil Capacity:** 21 Oz. (Crankcase)

**Fuel Capacity:** 2 Qts. (1.9 L)

## DRIVE

**Type:** Gear drive transmission w/chain and speed selection

**Speeds:** Three forward, one reverse

**Axle:** Solid

**Tires:** 4.10 x 3.50-6 Turf Saver pneumatic tires or  
4.10 x 3.50-6 Snow Hog tires.

**Tire Pressure:** 20 psi (136 kPa)

## IMPELLER

**Construction:** 4 steel blades

**Diameter:** 10 In. (25.4 cm)

**Bearings:** Prelubricated and sealed ball bearing

## AUGER

**Construction:** Ribbon flite welded steel

**Bearings:** Ultra High Molecular Weight  
Polyethylene

## BLOWER HOUSING

**Construction:** Welded Steel Stampings

**Effective Width:** 22 In. (55.88)

**Auger Opening Height:** 14 In (35 mm)

**Spout:** 186° rotation with adjustable deflector

**Scraper Bar:** Wear resistant steel

**Skid Shoes:** Adjustable, heat treated steel

## AUGER & IMPELLER DRIVE

**Type:** Cushion V-belt and worm gear housing

## OVERALL DIMENSIONS & WEIGHT

**Length:** 51 In. (130 cm)

**Width:** 24 In. (60.96 cm)

**Height:** 43-1/2 In. (110 cm)

**Weight:** 5 HP - 158 lbs. (72 kg)

7 HP - 178 lbs. (80 kg)

#### PARTS MANUAL AVAILABLE

*Simplicity* parts manuals are fully illustrated. All of the assemblies are shown in exploded views which show the relationship of the parts and how they go together. Important assembly notes and special torque values are included in the illustrations. For standard hardware, a torque specifications chart is included.

To order a Parts Manual for your snowthrower, fill out the form and enclose it in an envelope with a check or money order made out to *SIMPLICITY*.

Simplicity Manufacturing, Inc.  
Attn: Cashier  
500 N. Spring Street  
P.O. Box 210  
Port Washington, WI 53074

#### SERVICE MANUAL AVAILABLE

A Do-It-Yourself service manual is available from your dealer (part number 1678586). This manual contains fully illustrated step-by-step instructions for complete maintenance, troubleshooting and repair.

**Extend Equipment Life - Use Only Genuine  
Simplicity Repair Parts**

- I would like a Parts Manual (TP-1097) for my Snowthrower. I am enclosing a check or money order for \$5.50
- I would like a Service Manual (Part No. 1678586) for my Snowthrower. I am enclosing a check or money order for \$7.00
- Please include \$1.50 for postage and handling.

(Print clearly, this will be your mailing label.)

NAME \_\_\_\_\_

STREET OR RFD \_\_\_\_\_

CITY \_\_\_\_\_ STATE \_\_\_\_\_ ZIP \_\_\_\_\_

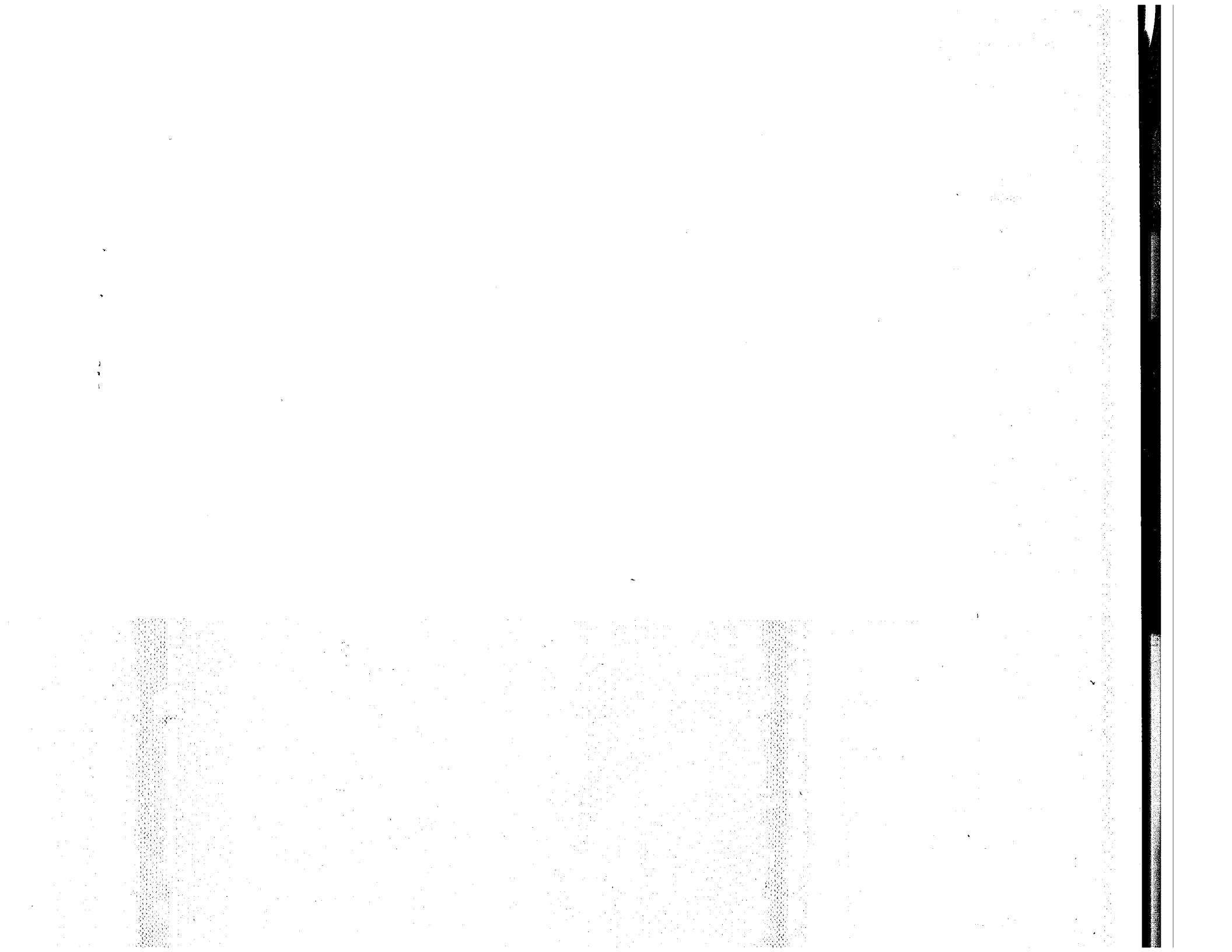

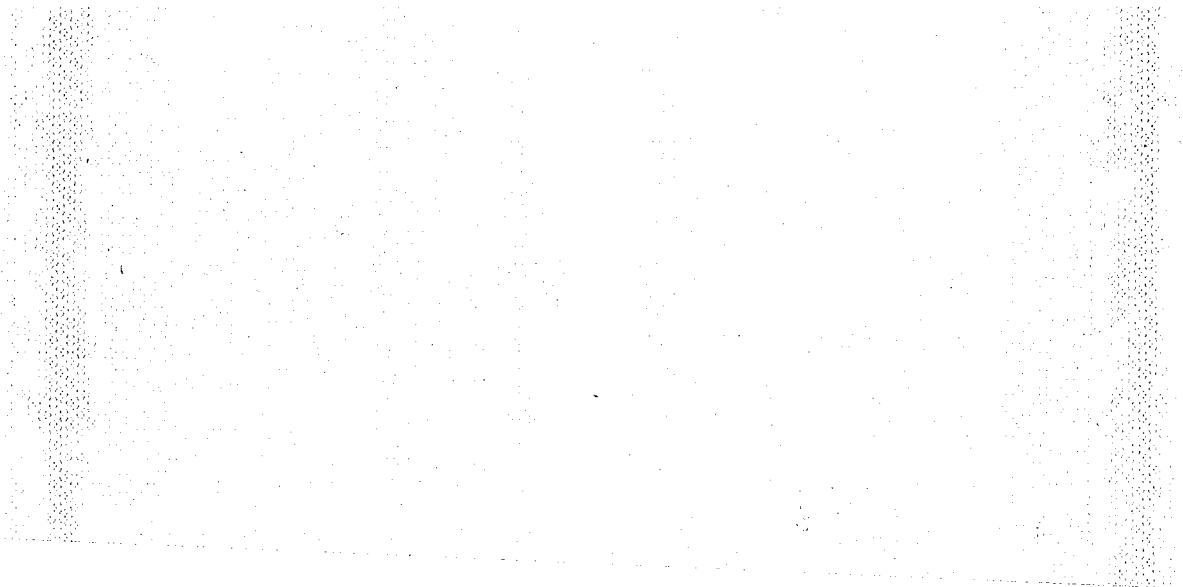

**SIMPLICITY MANUFACTURING, INC.**  
500 N. Spring St., P.O. Box 997  
Port Washington, WI USA 53074-0997

FORM-1701460-03  
PRINTED IN U.S.A.  
©1990 6/90