

# ***Simplicity***

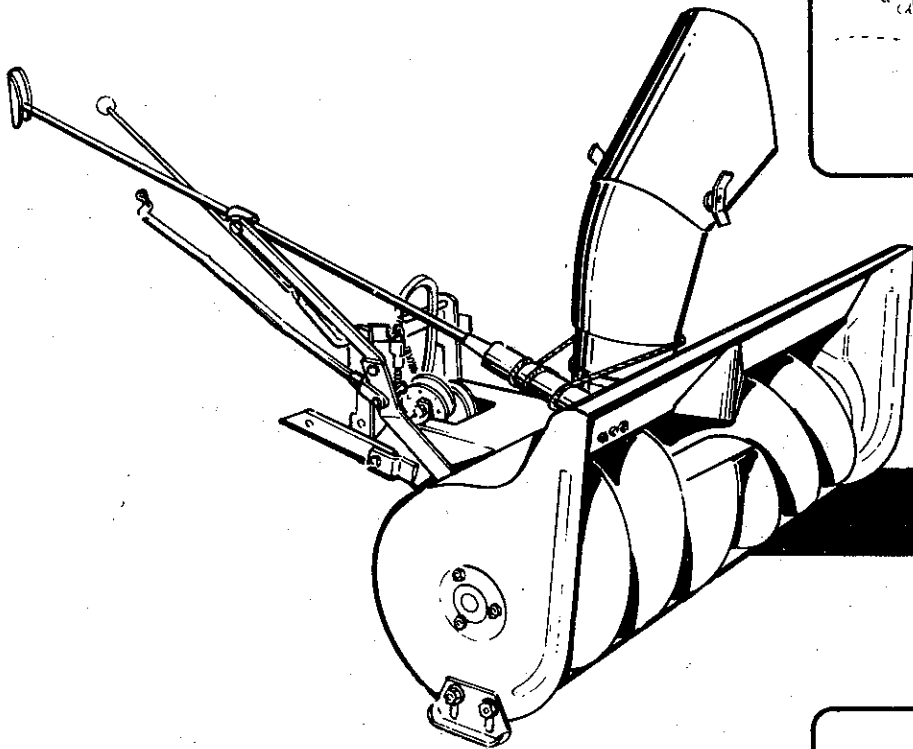

**MFRS. NO. 563**

**36" ROTARY  
SNOW THROWER**

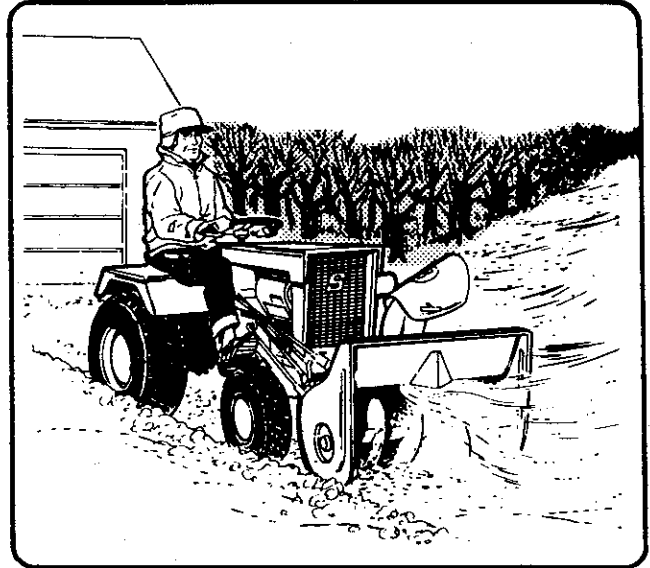

SER. FORM-P49

**SIMPLICITY MANUFACTURING COMPANY,**

**1317**

LITHO IN U.S.A.

---

## **SAFE SNOW REMOVAL IS NO ACCIDENT**

Improper use of snow removal equipment on the part of the operator can result in injury. To reduce this possibility, give complete and undivided attention to the job at hand.

Protect Yourself and Others By Following These Safety Tips.

1. Disengage power and stop motor before cleaning discharge, removing obstacles, making adjustment, or when leaving operating position.
  2. Never direct discharge at bystanders nor allow anyone in front of machine -- debris may be hidden in the snow.
  3. Keep children and pets a safe distance away.
  4. Do not allow children to operate machine nor allow adults to operate it without proper instructions.
  5. Adjust height to clear gravel or crushed rock surface.
  6. Exercise caution to avoid slipping or falling, especially when operating in reverse.
  7. Know the controls and how to stop quickly -- read the owner's manual.
  8. Handle gasoline with care -- it is highly flammable.
    - a. Use approved gasoline container.
    - b. Never add gasoline to a running motor -- fill tank out of doors and wipe up spilled gasoline.
    - c. Replace gasoline cap securely.
    - d. Open doors if motor is run in garage -- exhaust gases are dangerous.
  9. Disengage all clutches and shift into neutral before starting motor. Keep hands, feet and clothing away from power driven parts.
  10. Use a grounded three wire extension cord for all plug-in electric units.
  11. Keep machine in good operating condition and keep safety devices in place.
-

## PACKING INFORMATION

The Rotary Snow Thrower is delivered complete in one carton. The Carton contains:

- 1 Hitch Assembly
- 1 Lift Rod Assembly
- 1 Clutch Rod Assembly
- 1 Spout Control Rod
- 1 Spout Tube and Rope Assembly
- 1 Spout Control Rod Support
- 1 Heat Deflector Clamp
- 2 Skid Shoes
- 1 Engine Pulley
- 1 Clutch Rod Bracket

- 1 Pulley Cover
- 1 Spout Assembly
- 1 Body and Rotor Assembly
- 1 Bag of Hardware
- 1 Winter Gas Cap

Should any shortage of the above items occur, advise by stating packers number listed on green packing slip, part number and description of items missing.

1. For ease of access to the bearing housing rotate the body assembly so that front of the unit is flat on work surface. See Ill. at right. Block up the body assembly to avoid its moving or falling while it is in this upright position. See Ill. at the right.

2. Loosen the 5/16 - 18 x 1 - 1/2" lg. capscrew, 5/16" lockwasher and 5/16 - 18 full hex nut holding the belt guard assembly to the bearing housing. Slide the belt guard assembly out of the way along the bearing housing. See Ill. at right.

3. Secure the hitch assembly to the body assembly with (2) 3/8"-24 x 1-1/2" long hex capscrews, (2) 3/8 plain washers, (2) 3/8" spring washers and 3/8-24 hex nut, full lock, 3/8"-24. See illustration at right.

It is necessary for the hitch assembly to pivot so be sure not to fasten the hardware too tight.

4. Place the "V" belt around the pulley in the body housing. Slide the belt guard back to its normal position around the pulley. See Ill. at right. Make sure the top of the belt guard hits the under side of the housing assembly. See Ill. at right. At this time, secure the hardware loosened for Step 2 of these instructions.

5. On each side of the body assembly attach a skid shoe with (2) carriage bolts, 3/8 - 16 x 3/4 lg. (2) plain washers, 3/8, (2) lockwashers, 3/8" and (2) full hex nut, 3/8 - 16. The heads of the carriage bolts must be on the inside of the body assembly. See Ill. at right. Remove the blocking holding the rotor body assembly and return it to its normal position. Check to see that the skid shoes are flat on the bottom surface of the skid. See Ill. at right.

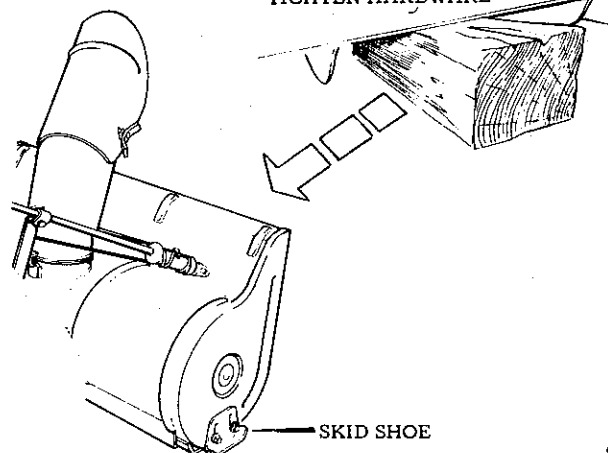
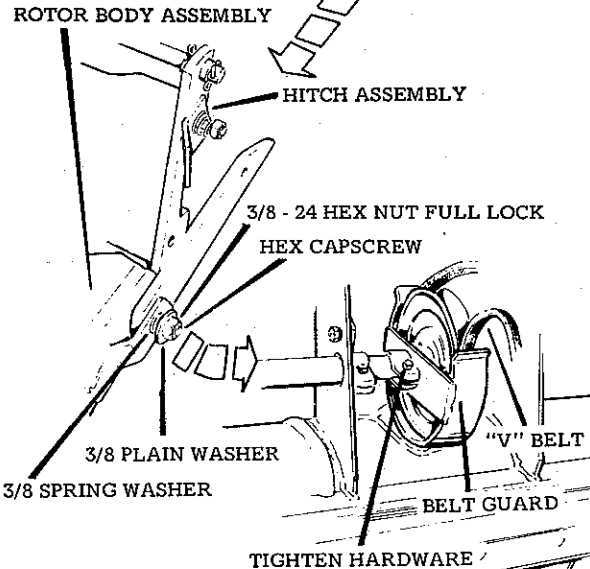
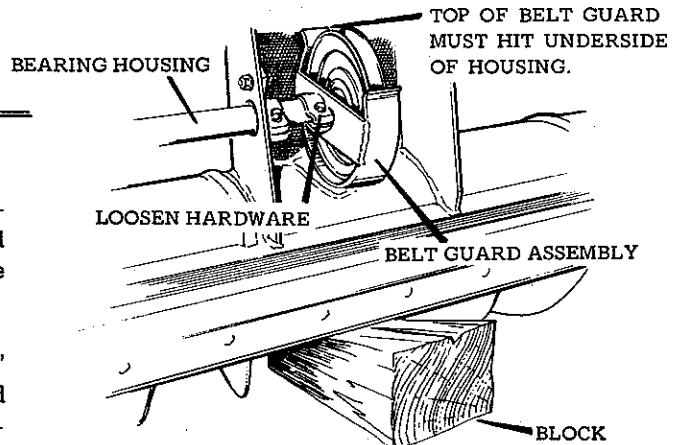

6. Line up the clip on the spout of the rotor body assembly with the notch on the spout assembly. With the clip and notch lined up, place the spout assembly over the spout of the rotor body assembly and rotate slightly right or left. See Ill. at right.

7. Assemble the spout extension to the spout assembly using two each of 5/16" - 18 x 3/4" carriage bolt, 3/8" special hex lockwasher, 3/8" plain washer and wing nuts. The points of the special hex lock washer are to face in towards the spout extension. See Ill. at right. Apply a light coat of oil to the neck of the discharge spout.

8. Install the rod guide support to the top hole of the bracket of the rotor body assembly. Fasten the rod guide support on the outside of this bracket using one each 3/8" 16 x 1 - 1/4 hex capscrew, 3/8" lockwasher and 3/8" - 16 hex nut. See Ill. at left.

9. Attach the spout control tube assembly to the rotor body assembly by pushing the rod of the spout control through the nylon bearing of the rotor body. For ease of installation, push the spout control rod as far as possible through the bearing before securing it with a 1/8" x 3/4" cotter pin. Now pull back on the control rod until it is possible to insert and secure the other 1/8" x 3/4" cotter pin. See Ill. at right.

10. Position the discharge spout directly forward. Position the control tube so the cable clamp is facing out. See Ill. at right. Provide 2-1/2 coils below the clamp and 2-1/2 coils above the clamp. The end of the cable above the clamp (closest to operator) passes under the tube and around the spout assembly. Place the loop of the cable over the stud of the spout assembly. The end of the cable below the clamp (closest to rotor body) passes over the tube and around the spout assembly. Place the loop end of the cable over the stud on the spout assembly and secure with a cup washer (edge of slip washer faces out), 5/16 - lockwasher and 5/16 - 18 full hex nut. Place the liner and rod guide over the spout control rod. Secure the rod guide to the outside of the rod guide support with a 5/16" - 18 x 1 - 1/4" long hex capscrew and a 5/16" - 18 full hex lock nut. Tighten securely enough to permit spout control rod to be turned with slight pressure applied. See Ill. at right.

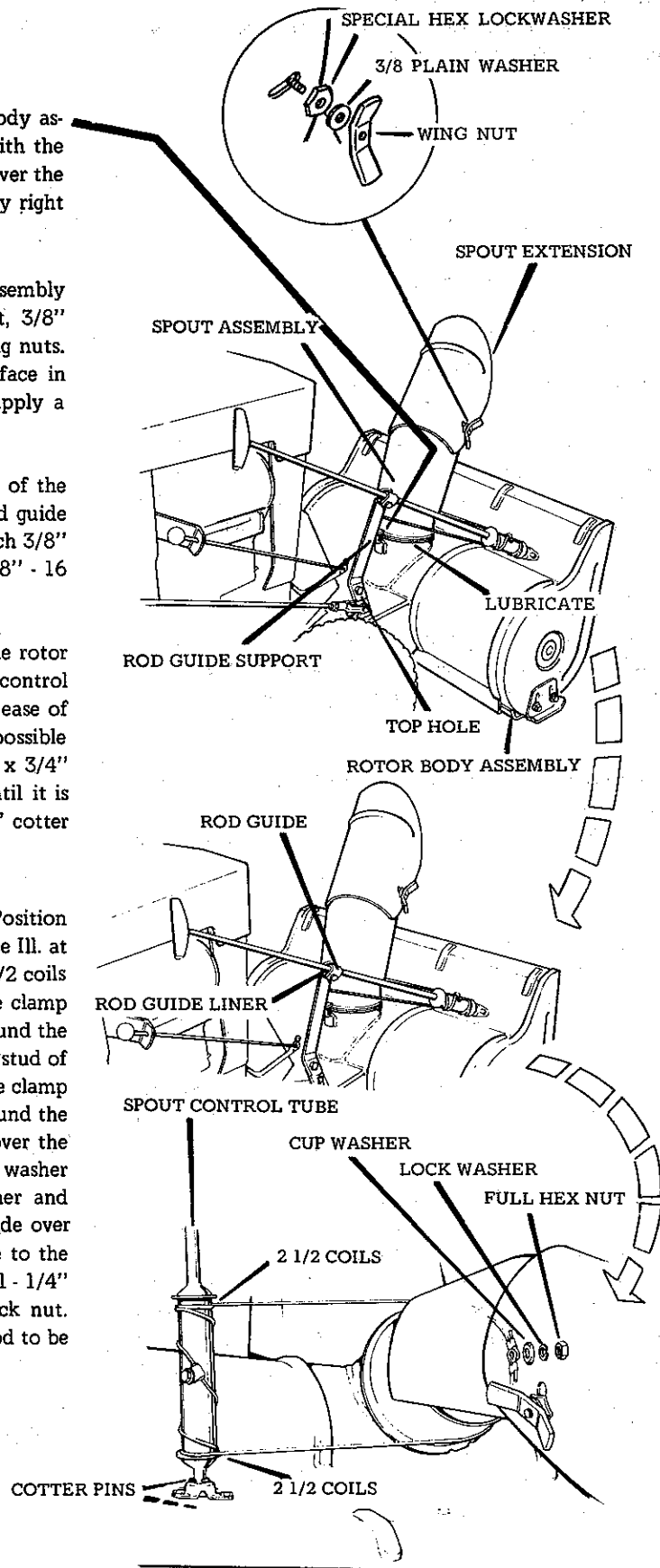

11. Remove protective cover from tractor PTO shaft. Remove all burrs and rough edges from keyway and bore of engine pulley. Apply a light coat of grease to front PTO shaft. Mount the engine pulley to the PTO shaft with the hub of pulley facing the tractor and the center of the pulley 3/4" from the end of the shaft. Secure the pulley to the PTO shaft with a key and 3/8" - 24 set screw. See Ill. at right.

12. Remove the 5/16" - 18 x 1 - 1/4" lg. hex capscrew, lock washer and plain washer from directly below the front PTO shaft of the tractor. Insert this capscrew through the two belt stops with the left hand belt stop next to the tractor and the right hand closest to the bolt head. Secure the capscrew with the belt stops approx. 1/16" away from the PTO pulley. See Ill. at right.

13. Remove forward, middle capscrew from right hand side panel. Insert clutch handle bracket between side panel and side member of fuel tank and steering post support assembly. Secure with same hardware removed above. See Ill. at left.

14. Replace the regular gas cap with the winter gas cap. See Ill. at right.

15. Position the heat deflector over the muffler to the inside of the exhaust port. Flap of the deflector is to be positioned against the air cleaner and adjacent to the engine. Secure with clamp.

**IMPORTANT**

To prevent exposure to carbon monoxide, the exhaust port of the muffler must be outside of the heat deflector and pointed forward and down at all times. Do not alter this position.

This deflector is provided for winter use only and must be removed in warm weather to prevent overheating and damage to the engine. See Ill. at right.

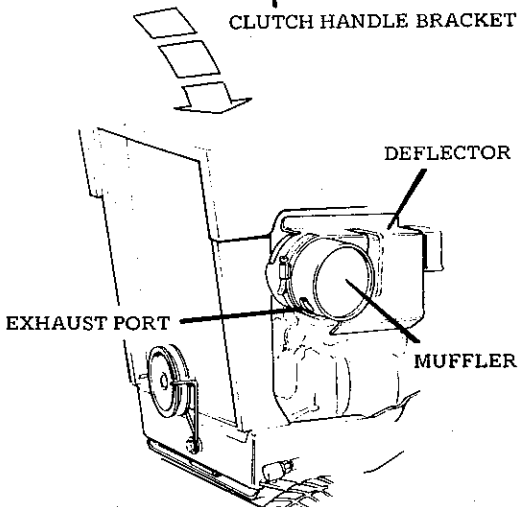
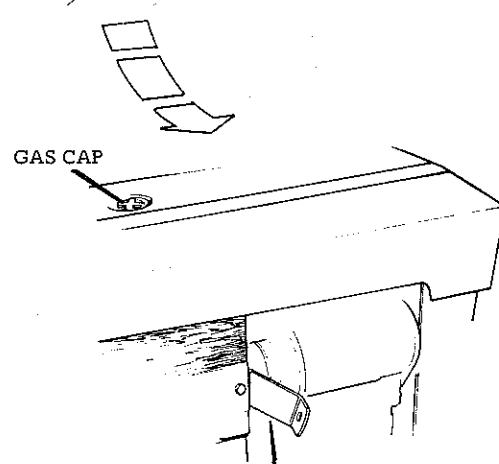
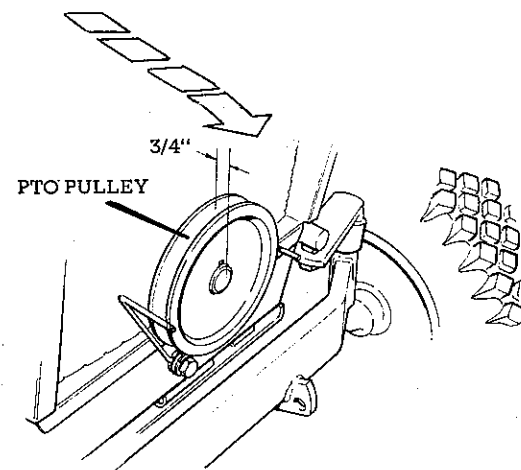
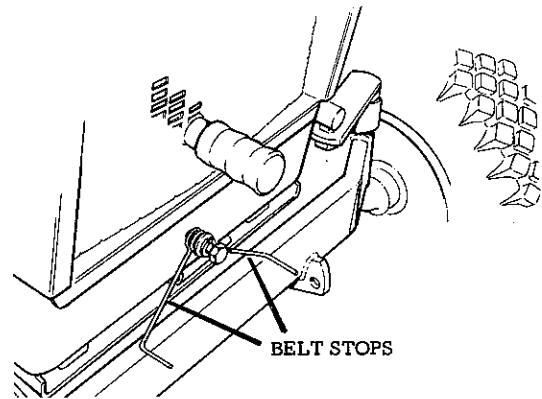

16. Mount the assembled snow thrower to the tractor. The cut out of the hitch assembly fits over the bumper of the tractor. The snow thrower is secured to the power unit with two each pins and spring cups. See Ill. at right.

NOTE: Make sure unit is free to pivot up and down.

17. Place belt around front mounted PTO pulley and set the two belt stops approx. 1/16" from pulley.

18. Place clutch handle through the bracket on the R.H. side of the tractor and secure to the hitch assembly with a spring clip. See Ill. at right. Engage unit and make certain that the belt stops are 1/16" from the belt. Hold stops in this position and secure the hardware holding them to the tractor.

19. Attach the lift rod to the lift lever on the tractor and the rotor body on the snow thrower; the clevis and pin will be on the tractor. Secure with spring clips.

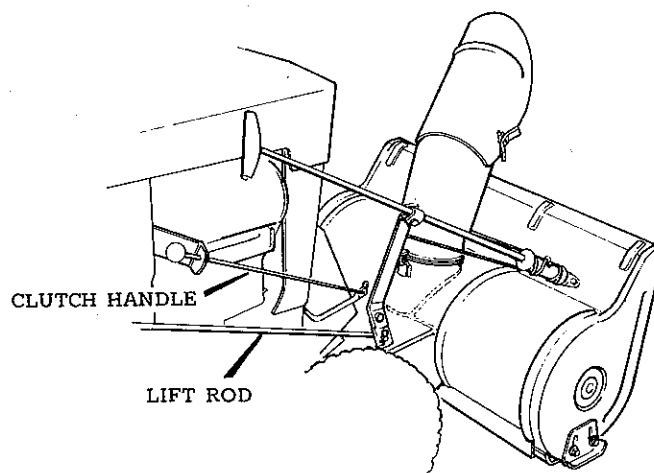
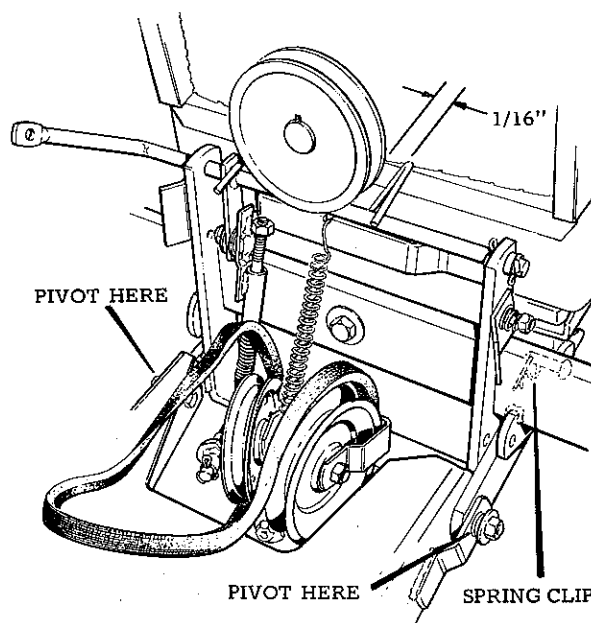

## OPERATION

1. Engagement of Snow Thrower is accomplished by pushing the clutch handle forward. Pull knob to operator for disengagement. It is **IMPORTANT** to maintain constant torque on the nut (Ref. Let. AP on Hitch & Pulley Group. This will keep Snow Thrower disengaged when clutch handle is in the disengaged position.

2. The skid shoes on each side of the rotor housing are adjustable either up or down, to suit the surface over which the snow thrower is to be operated. For a smooth surface, loosen the nuts and set the shoes so that the lower edge of the rotor housing rides on the surface. For use over an uneven or rough surface, adjust the shoes for maximum lift.

When using the snow thrower, set the discharge spout so that the snow will be thrown with the wind and never into the wind. Throwing snow into the wind will be a source of discomfort to the operator. To alter the direction of discharge, rotate the spout by means of the spout adjusting handle. The distance that the snow may be thrown may be adjusted by loosening the two wing nuts on the discharge

spout extension and raising or lowering the extension to give the desired angle. After adjusting, push the extension snugly against the spout assembly to prevent snow from being blown backwards against the tractor and the operator. Slotted holes beneath the wing nuts will allow this to be done before tightening the wing nuts to hold the extension in the desired position.

3. When operating through excessively heavy drifts of snow, pull back on the lift lever and raise the snow thrower while taking the first pass through the drift. Then back off and lower the snow thrower and go through again. After the first path through the drift has been opened, it may be convenient to use only a portion of the width of the snow thrower on succeeding passes. Naturally, efficient plowing methods will vary from one snowfall to another and from location to location. The operator must judge for himself which methods produce the best results.

## NOTE

4. When transporting the snow thrower from one location to another, disengage the power take-off and pull the lift lever back to the latched position and carry snow thrower in raised position.

5. When throwing snow, it is recommended that the tractor be operated in first or second gear and the throttle be at 3/4 to full, depending on conditions.

When operating in extremely heavy and/or wet snow, a path less than a full width should be taken. In this type of situation the operator should ease the blower into the snow by using the clutch and brake pedal and keeping the engine at top speed. This will alleviate the problem of the auger becoming plugged up and burning the belt.

## ADJUSTMENTS

1. Engine pulley must face toward grill. A dimension of 3/4" from the end of the engine shaft to the center of the groove of the pulley must be obtained for correct operation. See No. 1 in Illustration.

2. Adjust PTO tension spring so the spring is completely compressed when the belt is engaged. See No. 2 in Illustration.

PULLEY HUB MUST FACE  
TOWARDS GRILL OF TRACTOR

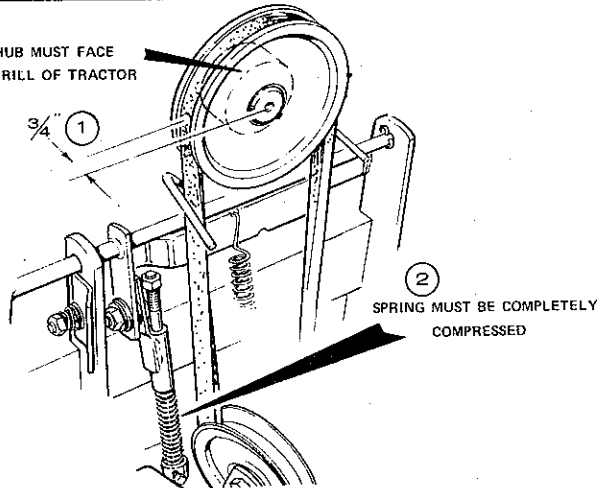

## LUBRICATION

There is one grease fitting on the Snow Thrower. See page 10. Lubricate with a general purpose automotive type grease every 15 hours of operation. Remove the chain guard and apply a coating of grease on chain every 15 hours of operation. Occasional application of light motor oil as indicated on Page 9 will also assist in the operation of the snow thrower.

## STORAGE

After completion of the plowing operation, allow the tractor engine to operate in a sheltered area for about 5 minutes to dry itself and prevent the formation of ice. When possible, store the snow thrower in a cold area so that clinging snow will not melt and re-freeze into ice.

## BELT REPLACEMENT

1. Remove the snow thrower from the tractor.
  - a. Disconnect the lift rod
  - b. Disconnect the clutch rod
  - c. Remove the belt from the engine pulley
  - d. Remove the two pins holding the snow thrower to the tractor
2. Turn the spout control rod to position the spout to either the left or right.
3. For easy accessibility, position the snow thrower on the front opening. A block placed under the unit will insure against tipping.
4. To keep the hitch assembly properly oriented, using a 9/16" socket and open end wrench, tighten one of the bolts holding the hitch assembly to the blower housing as shown at right.

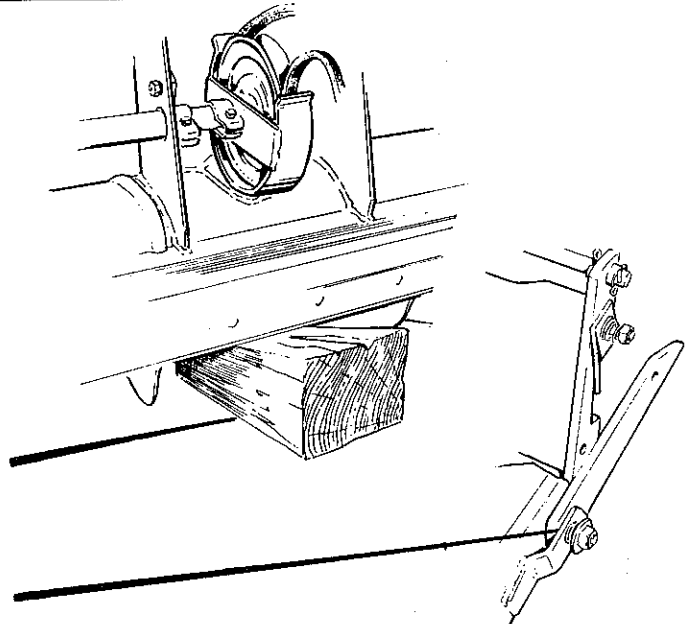

5. Remove defective belt. NOTE: If the belt is not broken, cut the belt for easy removal.

6. Using a 1/2" socket and open end wrench, loosen the belt guard and slide belt guard to the left. (See Ill. at right.)

7. Install the new belt around the pulley. Return the belt guard all the way to the right, being sure that the top of the belt guard is tight against the blower housing when tightening the guard bolt. (See Ill. at right.)

8. Using a 9/16" socket and open end wrench, remove the nut and the belt guard from the bolt holding the left side pulley. The bolt does not have to be completely removed from the pulley. (See Ill. at right.)

9. Position the new belt around the left side pulley as shown at right. Reinstall the belt guard and nut previously removed. Before tightening, be sure the belt guard is positioned as shown at right ( 90° to belt).

10. Using a 9/16" socket and open end wrench, remove the locknut holding the tension spring on the right side pulley, (left side from the top of snow thrower,) and remove the spring from the bolt. The other end of the spring can remain in position.

11. Loosen (but do not remove) the nut on the bolt holding the right side, (left side from the top of snow thrower) pulley and belt guard.

12. Install the new belt with the back of the belt against the pulley as shown at right. Retighten the nut holding the pulley and belt guard, being sure that the belt guard is positioned as shown at right.

13. Replace the end of the tension spring on the pulley bolt and reinstall and tighten the locknut. Be sure the belt guard remains in the proper position when tightening the locknut holding the spring.

14. Loosen the bolt holding the hitch assembly to the blower housing that was tightened in Step No. 4. The bolt must be loosened sufficiently to allow the hitch assembly to pivot freely.

15. Check to insure that the two belt guides next to the engine pulley on the tractor are within 1/16" of the pulley. Be sure the bolt holding these guides in place is tight.

16. Attach the snow thrower to the tractor, reversing Step No. 1, a. through d. when installing the belt around the engine pulley. Be sure the two belt guides remain 1/16" away from the belt when the belt is tight.

BELT GUARD MUST BE TIGHT AGAINST THE BLOWER HOUSING

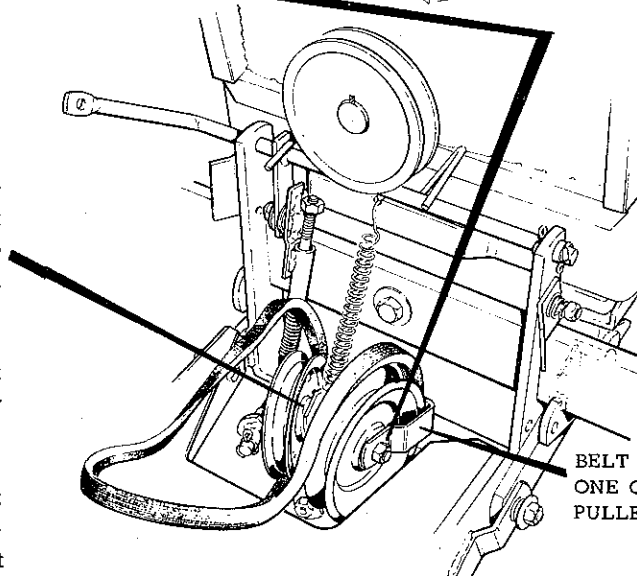
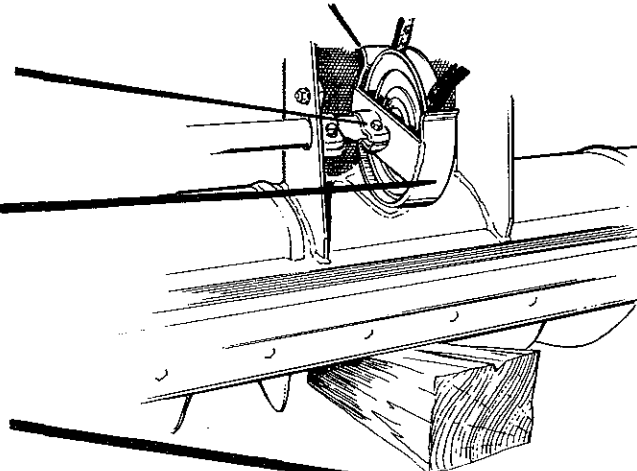

BELT GUIDES. ONE ON EACH PULLEY

PULLEY HUB MUST FACE TOWARDS GRILL OF TRACTOR

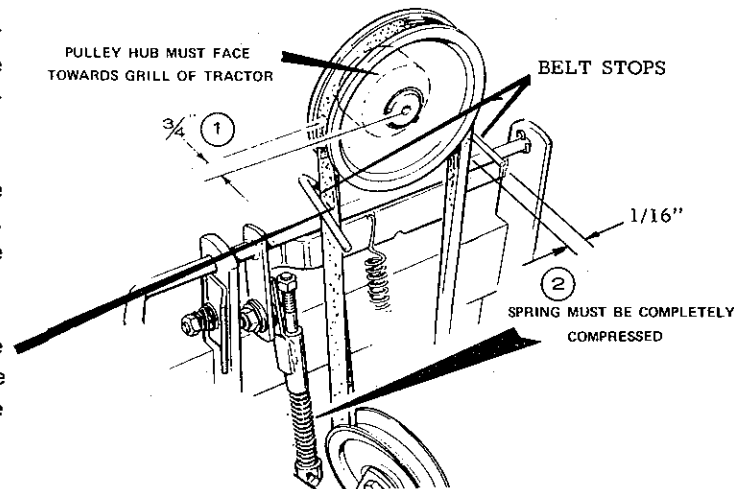

17. With the tractor engine off, engage the snow thrower and check to insure that the belt stops on the engine pulley and the belt guides on the left and right pulleys on the hitch assembly do not touch the belt and are positioned as shown above. Adjust as necessary. Disengage snow thrower.



# ROTOR, BODY & DRIVE GROUP

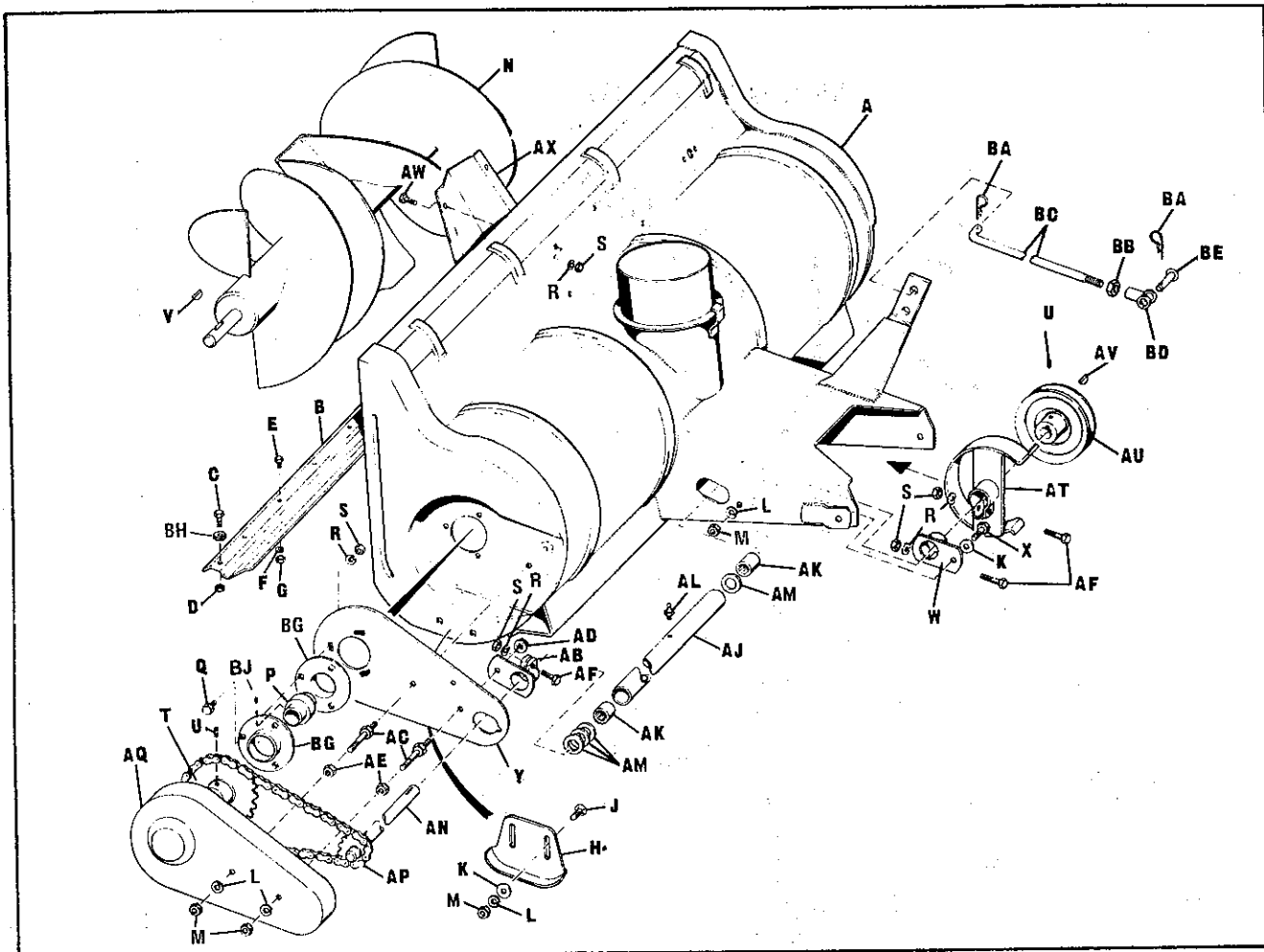

Ref. Let.	Part No.	Description
A	161202	Body Assembly
B	106863	Body Scraper
C	715071	Hex. Cap Screw, 5/16"-18 x 5/8"
D	717511	Full Lock Hex. Nut, 5/16"-18
E	715018	Hex. Cap Screw, 1/4"-20 x 5/8"
F	720003	Lock Washer, 1/4"
G	717005	Full Hex. Nut, 1/4"-20
H	106747	Skid
J	703004	Carriage Bolt, 3/8"-16 x 3/4"
K	719001	Plain Washer, 3/8"
L	720002	Lock Washer, 3/8"
M	717003	Full Hex. Nut, 3/8"-16
N	106856	Rotor Assembly
P	106732	Bearing Cartridge w/713509 Set Screw
Q	705017	Hex. Cap Screw, 5/16"-18 x 3/4"
R	720001	Lock Washer, 5/16"
S	717001	Full Hex. Nut, 5/16"-18
T	106653	Rotor Sprocket
U	713503	Set Screw, 5/16"-18 x 5/16"
V	151040	Hi-Pro Key
W	106476	Support Assembly Clamp
X	705005	Hex. Cap Screw, 3/8"-16 x 1"
Y	170754	Side Plate
AB	106476	Support Assembly Clamp

Ref. Let.	Part No.	Description
AC	106771	Stud
AD	718035	Nut, Flange, 3/8"-16
AE	717510	Full Lock Hex. Nut, 3/8"-16
AF	705018	Hex. Cap Screw, 5/16"-18 x 1-1/2"
AJ	106864	Bearing Housing
AK	154258	Needle Bearing
AL	727002	Grease Fitting
AM	8061012	Washer
AN	106860	Shaft Assembly
AP	106058	Chain
AQ	170865	Chain Guard
AT	106660	Belt Guard Assembly
AU	106663	Pulley
AV	725003	Key, 3/16" Dia. x 3/4"
AW	705012	Hex. Cap Screw, 5/16"-18 x 5/8"
AX	106774	Deflector
BA	106788	Spring Clip
BB	717008	Full Hex. Nut, 1/2" x 20
BC	106773	Front Lift Rod
BD	157631	Adjusting End Yoke
BE	154305	Yoke Pin
BG	161069	Bearing Flange
BH	719006	Washer
BJ	713509	Set Screw 1/4"-28 x 1 1/4 LG

## SPOUT GROUP

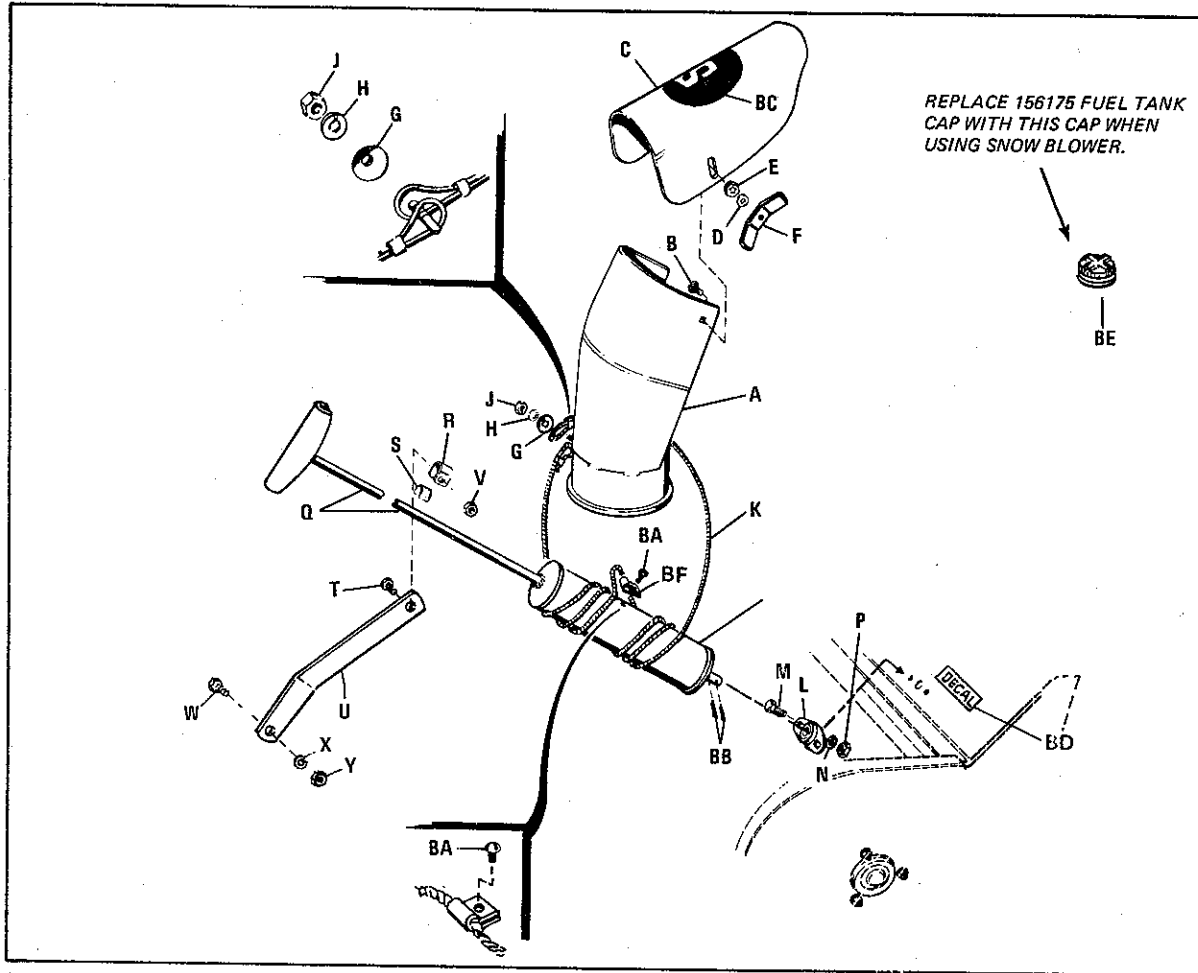

Ref. Let.	Part No.	Description
A	106762	Spout Assembly
B	703005	Carriage Bolt, 5/16"-18 x 3/4"
C	106760	Spout Extension
D	719001	Plain Washer, 3/8"
E	721601	Special Hex. Lock Washer, 3/8"
F	106229	Wing Nut
G	106785	Cup Washer
H	720001	Lock Washer, 5/16"
J	717001	Full Hex. Nut, 5/16"-18
K	161133	Cable Assembly
L	106491	Bearing
M	705015	Screw Hex Cap 16 1/4"-20 x 5/8" LG
N	720003	Lock Washer, 1/4"
P	717005	Full Hex. Nut, 1/4"-20
Q	170132	Tube Assembly - Spout Control

Ref. Let.	Part No.	Description
R	152050	Rod Guide
S	121175	Guide Liner
T	705019	Hex. Capscrew, 5/16"-18x1-1/4"
U	106666	Rod Guide Support
V	717511	Full Hex. Lock Nut, 5/16"-18
W	705016	Hex. Capscrew, 3/8"-16x1-1/4"
X	720002	Lock Washer, 3/8"
Y	717003	Hex. Nut, 3/8"-16
BA	715067	Self-Tapping Screw, 1/4-20 x 3/8"lg.
BB	722016	Cotter Pin, 3/32" x 5/8"
BC	161252	Decal
BD	161247	Safety Decal
BE	106798	Cap-Fuel, Tank
BF	154247	Clamp (For Service Only)

## HITCH & PULLEY GROUP

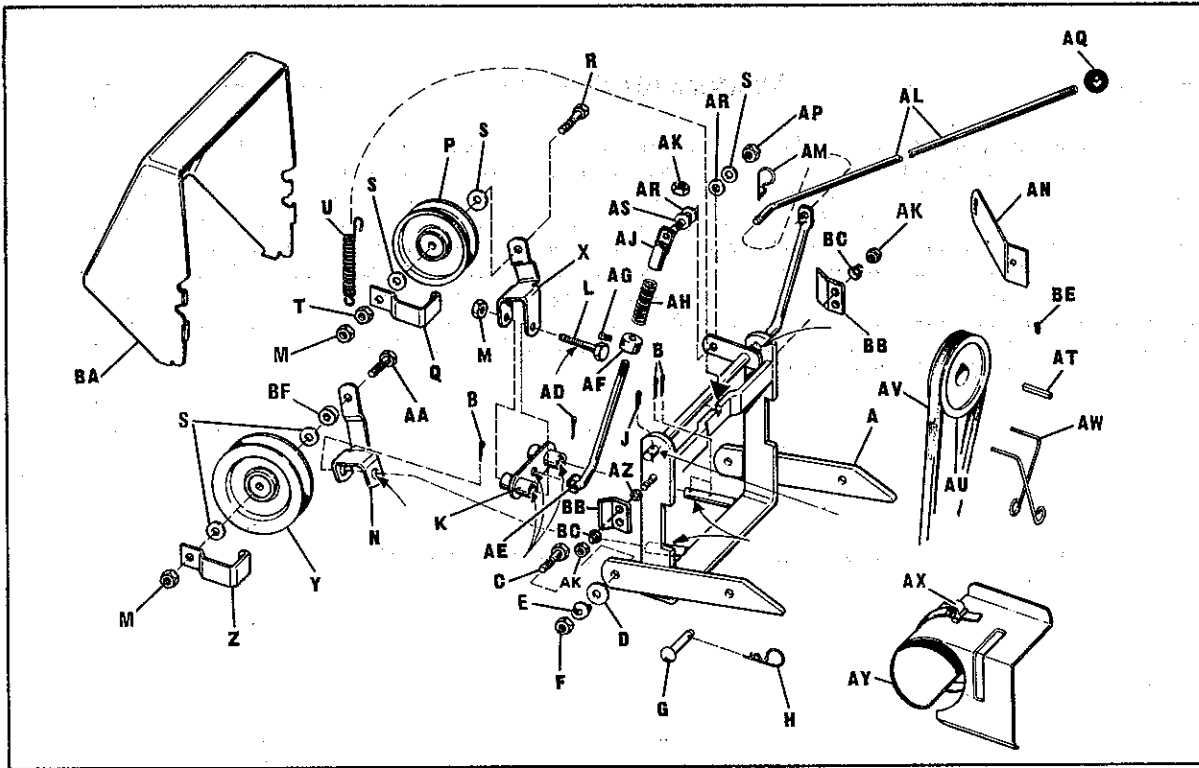

Ref. Let.	Part No.	Description
A	106726	Hitch Assembly
B	722006	Cotter Pin, 1/8" Dia. x 1"
C	121184	Hex. Cap Screw
D	719001	Plain Washer, 3/8"
E	721701	Spring Washer, 3/8"
F	717515	Full Lock Hex Nut, 3/8"-24
G	118053	Pin
H	106788	Spring Clip
J	722006	Cotter Pin, 1/8" Dia. x 1
K	106674	Lever Ass'y Idler
L	705003	Hex. Cap Screw
M	717510	Full Lock Hex. Nut, 3/8"-16
N	161154	Idler Bracket
P	106716	Idler Pulley
Q	106717	Guide Belt
R	705009	Hex. Cap Screw, 3/8"-16 x 1-1/2"
S	719002	Plain Washer, 5/16"
T	717013	Hex. Jam Nut
U	106681	Return Spring
X	106694	Idler Bracket
Y	101096	Idler Pulley
Z	106690	Belt Guide
AA	705016	Hex. Cap Screw, 3/8"-16 x 1-1/4"
AD	722001	Cotter Pin, 3/32" Dia. x 3/4"
AE	106770	Clutch Rod

Ref. Let.	Part No.	Description
AF	8191022	Set Collar
AG	713001	Set Sq. Hd. Cup Pt. Screw, 1/4"-20 x 3/8" lg.
AH	8191045	Spring
AJ	106768	Road Assembly Guide
AK	717511	Hex. Full Lock Nut, 5/16"-18
AL	106710	Clutch Handle
AM	106787	Spring Clip
AN	106687	Bracket
AP	717525	Nut, Stop, 5/16"-18
AQ	122005	Knob
AR	159134	Nylon Washer
AT	159129	Key
AU	106761	Engine Pulley
AV	106769	V-Belt
AW	106707	Belt Stop
AX	106692	Deflector Clamp
AY	106789	Heat Deflector
AZ	106731	Spacer
BA	106730	Cover, Pulley
BB	106728	Clip, Pulley Cover
BC	157127	Spring, Concial
BE	715049	Set Screw
BF	154177	Bushing

## WARRANTY

The company warrants Simplicity Products to be free from defects in material and workmanship except the company makes no warranty express or implied with respect to tires, engines and engine accessories which generally are warranted by their respective manufacturers. Any part covered by this warranty which is proven defective within one year, under normal use, from date of purchase, will be replaced free of charge, f.o.b. Port Washington, Wisconsin, provided such part is returned to factory transportation charges prepaid and is found to be defective upon examination at the factory. The company is not obligated under this warranty to bear cost of labor or delivery charges in replacement of defective parts. This warranty does not apply to any Simplicity Products altered outside of Simplicity's factory. Such replacement of defective parts shall be the exclusive remedy and in no event shall Simplicity be liable for consequential damages. EXCEPT AS SPECIFICALLY PROVIDED HEREIN, THERE ARE NO WARRANTIES WHICH EXTEND BEYOND THE DESCRIPTION ON ANY SIMPLICITY PRODUCT.

Should warranty service be necessary, the information below should be presented to the authorized SIMPLICITY Dealer.

Customer's Name \_\_\_\_\_

Address \_\_\_\_\_

Mfg. No. \_\_\_\_\_ Serial No. \_\_\_\_\_

Date Purchased \_\_\_\_\_

Purchased From \_\_\_\_\_

Address \_\_\_\_\_

Engine Model No. \_\_\_\_\_ Serial No. \_\_\_\_\_ Type No. \_\_\_\_\_

To obtain replacement parts from dealer, advise quantity, part number and description.



Remember...

### FOR YOUR SAFETY

1. ALWAYS STOP ENGINE BEFORE LEAVING MACHINE
2. ALWAYS STOP ENGINE BEFORE SERVICING OR ADJUSTING MACHINE OR EQUIPMENT
3. ALWAYS KEEP HANDS, FEET AND CLOTHING AWAY FROM POWER-DRIVEN PARTS