

# Attachment Illustrated Parts List



## Attachment

Mfg. No.	Description
1694401	Deluxe Hard Snow Cab

## **Simplicity**

MANUFACTURING, INC.  
500 N. Spring Street / PO Box 997  
Port Washington, WI 53074-0997 USA

[www.simplicitymfg.com](http://www.simplicitymfg.com)

© Copyright 2007 Simplicity Manufacturing, Inc. All Rights Reserved. Printed In USA.

**Part No.:** 1731934

**Rev.** 01/2007

TP 400-4281-00-AT-SMA

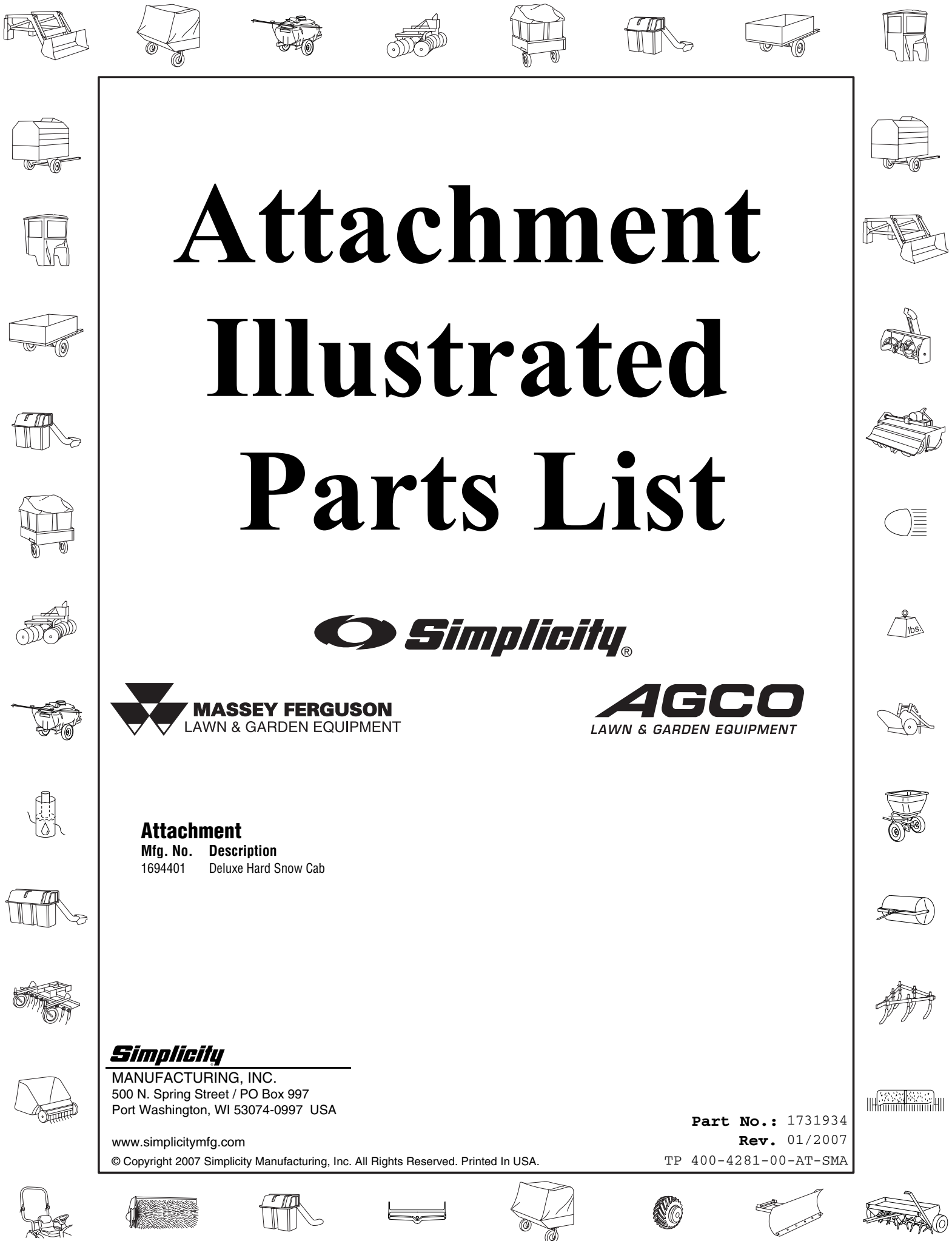



<b>PRODUCT COMPONENTS</b>	<b>PAGES</b>
Additive Parts Group .....	4
Electrical Controls Group .....	6
Frame Group .....	8
Front Windshield Group .....	10
Glass Door Group .....	12
Rear Windshield Group .....	14
Roof Group .....	16
<b>Torque Specification Chart .....</b>	<b>Inside Back Cover</b>

## Additive Parts Group

1\4281apg

NOTE: Unless noted otherwise,  
use the standard hardware torque  
specification chart.

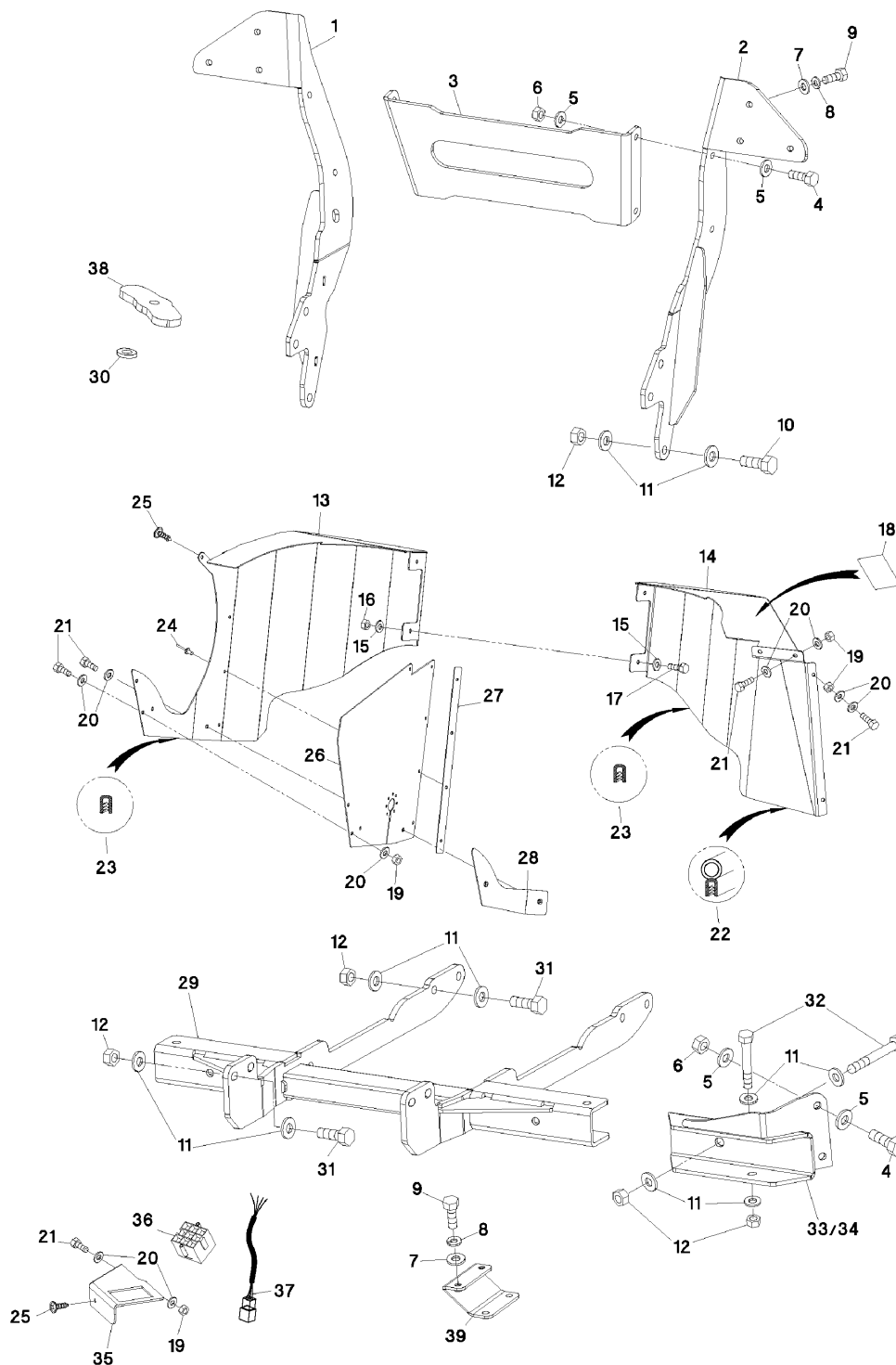

The above parts group applies to the following Mfg. Nos.:  
1694401 - Deluxe Hard Snow Cab

## Additive Parts Group

REF NO	PART NO.	QTY.	DESCRIPTION
1	1732678SM	1	Strut right
2	1732677SM	1	Strut left
3	1732690SM	1	Cross-stay below
4	1732639SM	8	Hexagon head screw M10x30
5	1732657SM	16	Shim disk M10
6	1732649SM	8	Stop nut M10
7	1732656SM	8	Shim disk M8
8	1732661SM	8	Retainer ring M8
9	1732638SM	8	Hexagon head screw M8x25
10	1732631SM	6	Hexagon head screw M12x45
11	1732658SM	36	Shim disk M12
12	1732650SM	18	Stop nut M12
13	1732680SM	1	Spoiler right
14	1732679SM	1	Spoiler left
15	1732655SM	4	Shim disk M6
16	1732647SM	2	Stop nut M6
17	1732635SM	2	Hexagon head screw M6x16
18	1732682SM	1	Sticker
19	1732646SM	8	Stop nut M5
20	1732654SM	16	Shim disk M5
21	1732634SM	8	Hexagon head screw M5x20
22	1721316SM	0.3m	Tube profile
23	1732713SM	1m	Edge-protection small
24	1732663SM	4	Blind rivet 4x12
25	1721415SM	2	Sheet metal screw 4.8x16
26	1732692SM	1	Brake pedal cover
27	1732686SM	1	Strip
28	1732685SM	1	Screw-on plate
29	1732681SM	1	Attachment bracket
30	1732709SM	2	Spacer
31	1732633SM	8	Hexagon head screw M12x40
32	1732632SM	4	Hexagon head screw M12x100
33	1732675SM	1	Bracket front left
34	1732676SM	1	Bracket front right
35	1732687SM	1	Mounting fuse box
36	1732707SM	1	Fuse box
37	1732683SM	1	Cable loom
38	1732691SM	2	Safety belt fastening
39	1732688SM	1	Mounting front-loader locking device

## Footnotes

**The above parts group applies to the following Mfg. Nos.:**

1694401 - Deluxe Hard Snow Cab

## Electrical Controls Group

1\4281ecg

NOTE: Unless noted otherwise,  
use the standard hardware torque  
specification chart.

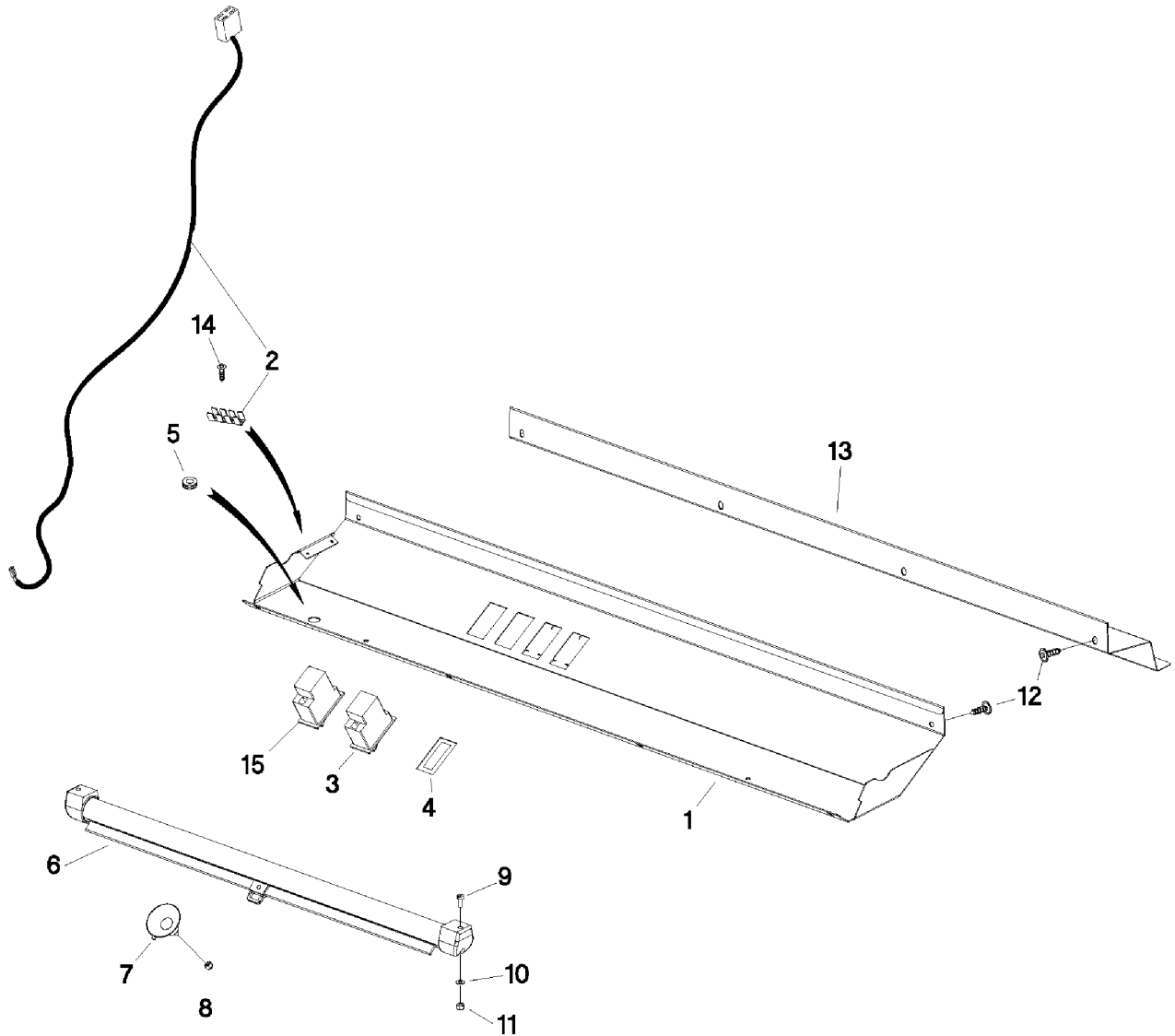

The above parts group applies to the following Mfg. Nos.:

1694401 - Deluxe Hard Snow Cab

## **Electrical Controls Group**

---

<b>REF NO</b>	<b>PART NO.</b>	<b>QTY.</b>	<b>DESCRIPTION</b>
1	1732684SM	1	Frame cover panel front top
2	1732683SM	1	Cable loom
3	1732708SM	1	Switch wiper-washer system
4	1732715SM	2	Blind cover
5	1721319SM	3	Blind plug 12mm
6	1732599SM	1	Sun blind
7	1721438SM	1	Nipple with screw
8	1721437SM	1	Cap nut M4
9	1732641SM	2	Oval countersunk head screw M4x15
10	1732653SM	2	Shim disk M4
11	1732645SM	2	Nut M4
12	1721415SM	10	Sheet metal screw 4.8x16
13	1732666SM	1	Frame cover panel rear top
14	1732643SM	2	Sheet metal screw 3.5x16
15	1732714SM	1	Switch (13.350) 1-stage

### **Footnotes**

---

**The above parts group applies to the following Mfg. Nos.:**

1694401 - Deluxe Hard Snow Cab

## Frame Group

1\4281fg

NOTE: Unless noted otherwise,  
use the standard hardware torque  
specification chart.

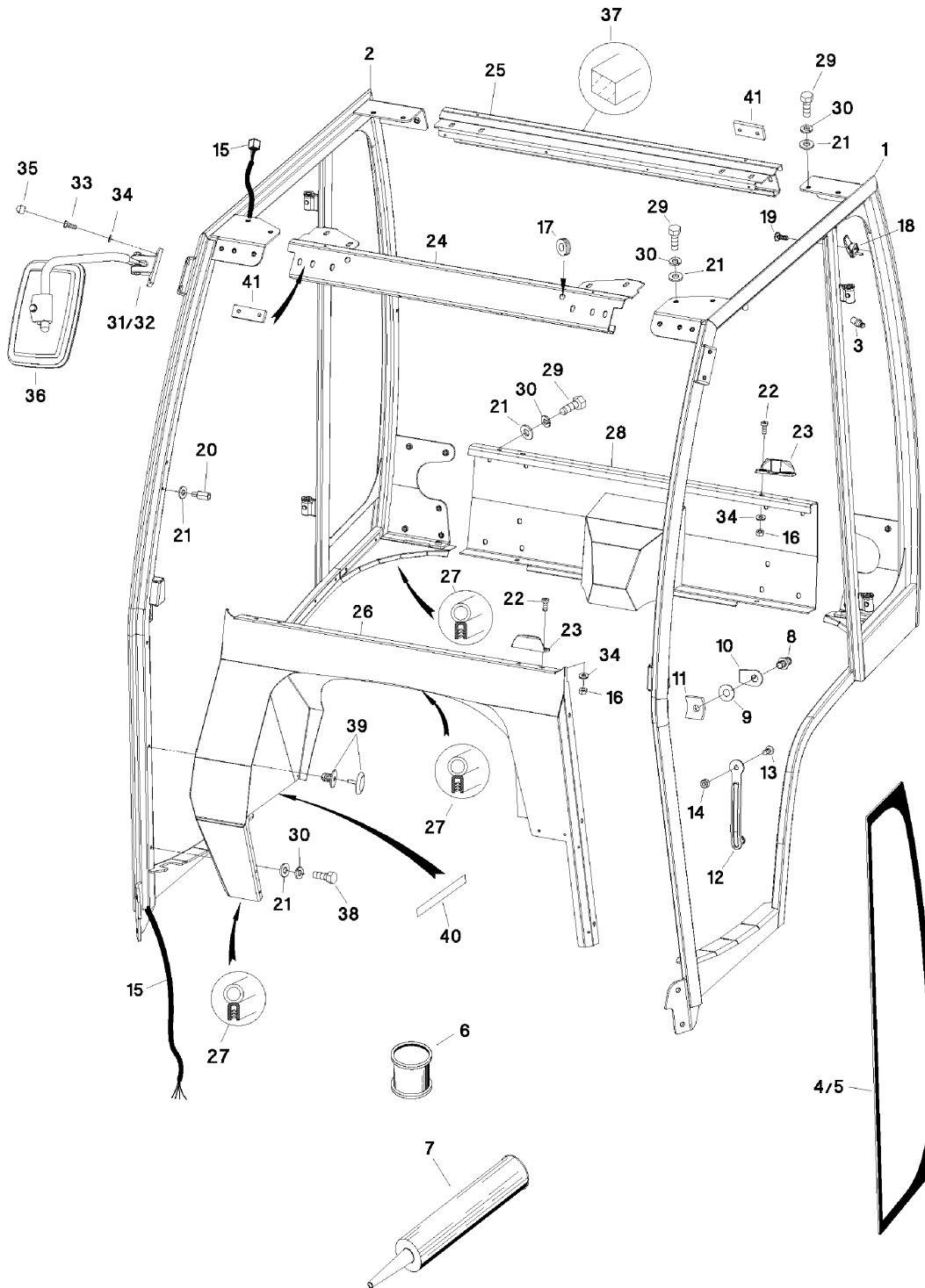

The above parts group applies to the following Mfg. Nos.:  
1694401 - Deluxe Hard Snow Cab



## Frame Group

REF NO	PART NO.	QTY.	DESCRIPTION
1	1732671SM	1	Side frame left
2	1722672	1	Side frame right
3	1732662SM	4	Impact nipple H1 d=6mm
4	1732703SM	1	Glass SH left
5	1732689SM	1	Glass SH right
6	*	1	Activator 30ml
7	*	1	Adhesive for panel (Sikadrive)
8	1721434SM	2	Locking pin 13mm
9	1732597SM	2	Washer
10	1732696SM	2	Slide-off strap
11	1732695SM	2	Threaded plate
12	1721391SM	2	Door push-out
13	1732640SM	2	Countersunk head screw M8x20
14	1732648SM	2	Stop nut M8
15	1732683SM	1	Cable loom
16	1732647SM	8	Stop nut M6
17	1732664SM	4	Blind plug 18mm
18	1732700SM	1	Coat hook
19	1732642SM	1	Sheet metal screw 3.9x13
20	1721313SM	2	Pneumatic spring sleeve l=22mm / 2x M8
21	1732656SM	25	Shim disk M8
22	1732644SM	8	Oval head screw M6x16 cross-recessed
23	1732710SM	4	Locking device
24	1732669SM	1	Cross-strut front above
25	1732670SM	1	Cross-strut rear above
26	1732673SM	1	Front panel
27	1721316SM	3.9m	Tube profile
28	1732674SM	1	Rear panel
29	1732637SM	18	Hexagon head screw M8x20
30	1732661SM	23	Retainer ring
31	1732699SM	1	Mirror left complete 602001 (Includes Ref. No. 36)
32	1732698SM	1	Mirror left complete 602001 (Includes Ref. No. 36)
33	1732635SM	6	Hexagon head screw M6x16
34	1732655SM	10	Shim disk M6
35	1732717SM	4	Cover cap d=6mm
36	**	1	Mirror
37	1721323SM	3.4m	Compriband A20/15
38	1732636SM	5	Hexagon head screw M8x12
39	1732712SM	1	Expansion rivet
40	1732665SM	0.3m	Velour band
41	1732711SM	8	Distance plate hinge t=8mm

### Footnotes

NOTE\* Not a serviceable part.

NOTE\* Not a serviceable part.

**The above parts group applies to the following Mfg. Nos.:**

1694401 - Deluxe Hard Snow Cab

# Front Windshield Group

1\4281fwg

**NOTE:** Unless noted otherwise,  
use the standard hardware torque  
specification chart.

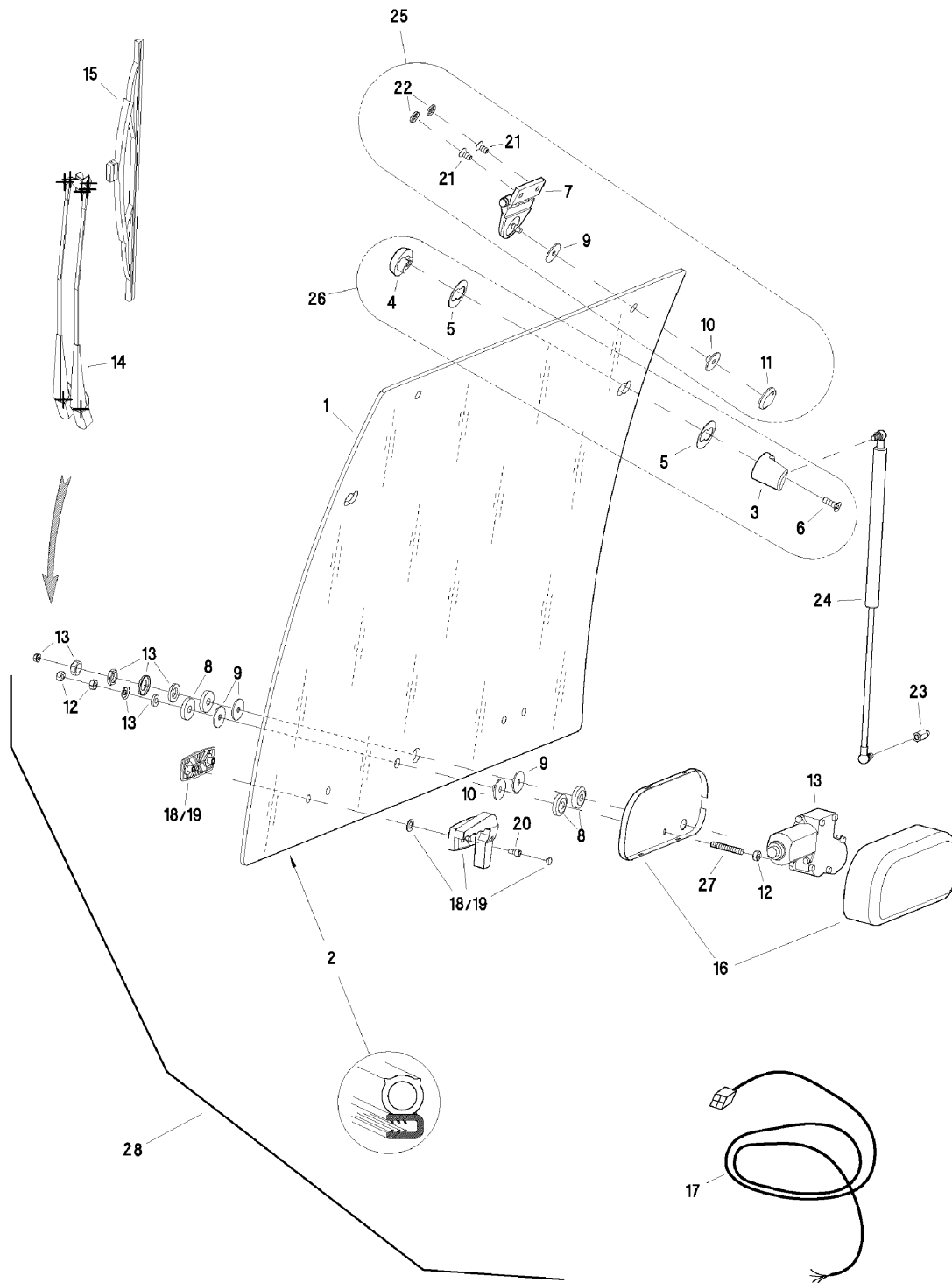

**The above parts group applies to the following Mfg. Nos.:**  
1694401 - Deluxe Hard Snow Cab

## Front Windshield Group

REF NO	PART NO.	QTY.	DESCRIPTION
1	*	1	Glass WS
2	1721325SM	4 lfm	Sealing tube profile
3	*	2	Pneumatic spring mounting inside
4	1721335SM	2	Pneumatic spring mounting outside
5	1721431SM	4	Rubber washer
6	*	2	Countersunk head screw M8x25
7	1721336SM	2	PVC hinge complete
8	1721432SM	4	PVC-disk
9	1721427SM	5	Rubber washer
10	1721428SM	3	Rubber washer with neck
11	1721429SM	2	PA - disk M8
12	1732648SM	3	Nut M8
13	1732721SM	1	Wiper motor 85 degrees / 12V
14	1732719SM	1	Wiper arm 400-500mm lg.
15	1732718SM	1	Wiper blade 450mm lg.
16	1732720SM	1	Cover wiper motor
17	1732702SM	1	Cable harness wiper motor
18	1732705SM	1	Locking device handle left
19	1732706SM	1	Locking device handle right
20	*	4	Socket head screw (hexagon socket)M6x12
21	*	4	Countersunk head screw M8x35
22	1721433SM	4	Cover cap countersunk head screw
23	1721313SM	2	Pneumatic spring sleeve l=22mm 2x M8
24	1732598SM	2	Pneumatic spring 320mm 150N
25	1721348SM	2	Set of hinges
26	1721349SM	2	Set of pneumatic spring mounting
27	1732701SM	1	M8 threaded rod l=75mm
28	1732697SM	1	Windshield complete (Includes all ref. nos. except ref. nos. 21 & 22)

### Footnotes

NOTE\* Not a serviceable part, must order complete windshield.

---

**The above parts group applies to the following Mfg. Nos.:**

1694401 - Deluxe Hard Snow Cab

## Glass Door Group

1\4281gdg

**NOTE:** Unless noted otherwise,  
use the standard hardware torque  
specification chart.

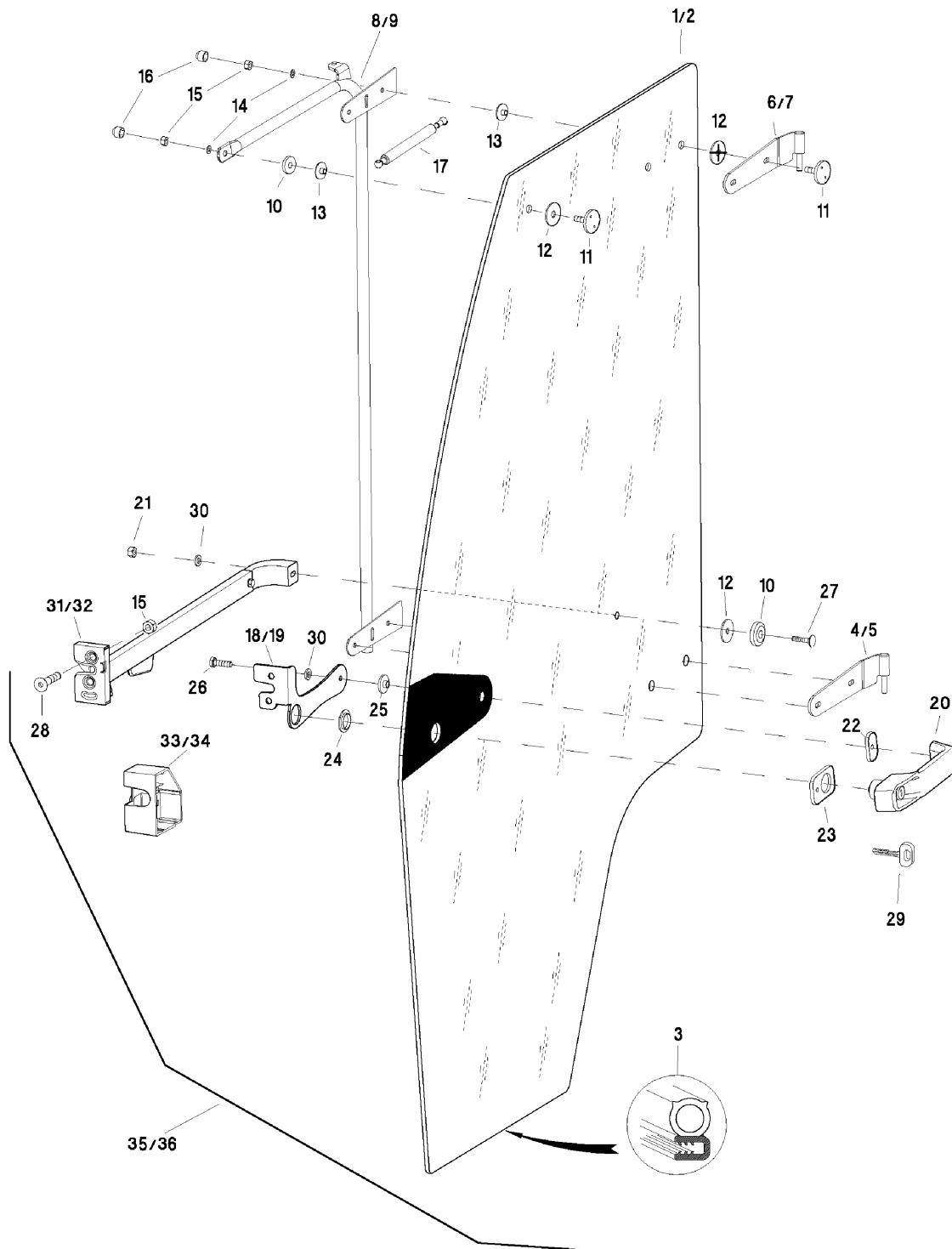

**The above parts group applies to the following Mfg. Nos.:**

1694401 - Deluxe Hard Snow Cab

## Glass Door Group

REF NO	PART NO.	QTY.	DESCRIPTION
1	*	1	Door window glass left
2	*	1	Door window glass right
3	1721325SM	4.4m	Sealing tube profile
4	*	1	Door hinge bottom left
5	*	1	Door hinge bottom right
6	*	1	Door hinge top left
7	*	1	Door hinge top right
8	*	1	Door strap left
9	*	1	Door strap right
10	1721432SM	1	PVC - disk
11	1721435SM	5	PVC - disk with screw M8x30
12	1721427SM	5	Rubber washer
13	1721428SM	5	Rubber washer with neck
14	1732656SM	5	Shim disk M8
15	1732648SM	6	Stop nut M8
16	1721402SM	6	Cover cap dm8
17	1721376SM	1	Pneumatic spring 320mm300N w/end-damp
18	1721374SM	1	Lock plate for complete glass door left
19	1721375SM	1	Lock plate for complete glass door right
20	1721377SM	1	Door handle with lockable latch
21	1732647SM	1	Stop nut M6
22	1721378SM	1	Rubber shim medium
23	1721379SM	1	Rubber shim large
24	1721380SM	1	Rubber washer with neck large
25	1721381SM	1	Rubber washer with neck small
26	*	1	Hexagon head screw M6x20
27	*	1	Hinge plate screw M6x30
28	*	1	Countersunk head screw M8x40
29	1721387SM	1	Key
30	1732655SM	2	Shim disk M6
31	1721382SM	1	Turn-catch lock left with cross arm
32	1721384SM	1	Turn-catch lock right with cross arm
33	1721383SM	1	Lock cover left
34	1721385SM	1	Lock cover right
35	1732693SM	1	Door left complete (Includes all ref. nos. except ref. nos. 2, 5, 7, 9, 19, 32 & 34)
36	1732694SM	1	Door right complete (Includes all ref. nos. except ref. nos. 1, 4, 6, 8, 18, 31 & 33)

### Footnotes

NOTE\* Not a serviceable part, must order complete door.

**The above parts group applies to the following Mfg. Nos.:**

1694401 - Deluxe Hard Snow Cab

## Rear Windshield Group

1\4281rwg

NOTE: Unless noted otherwise,  
use the standard hardware torque  
specification chart.

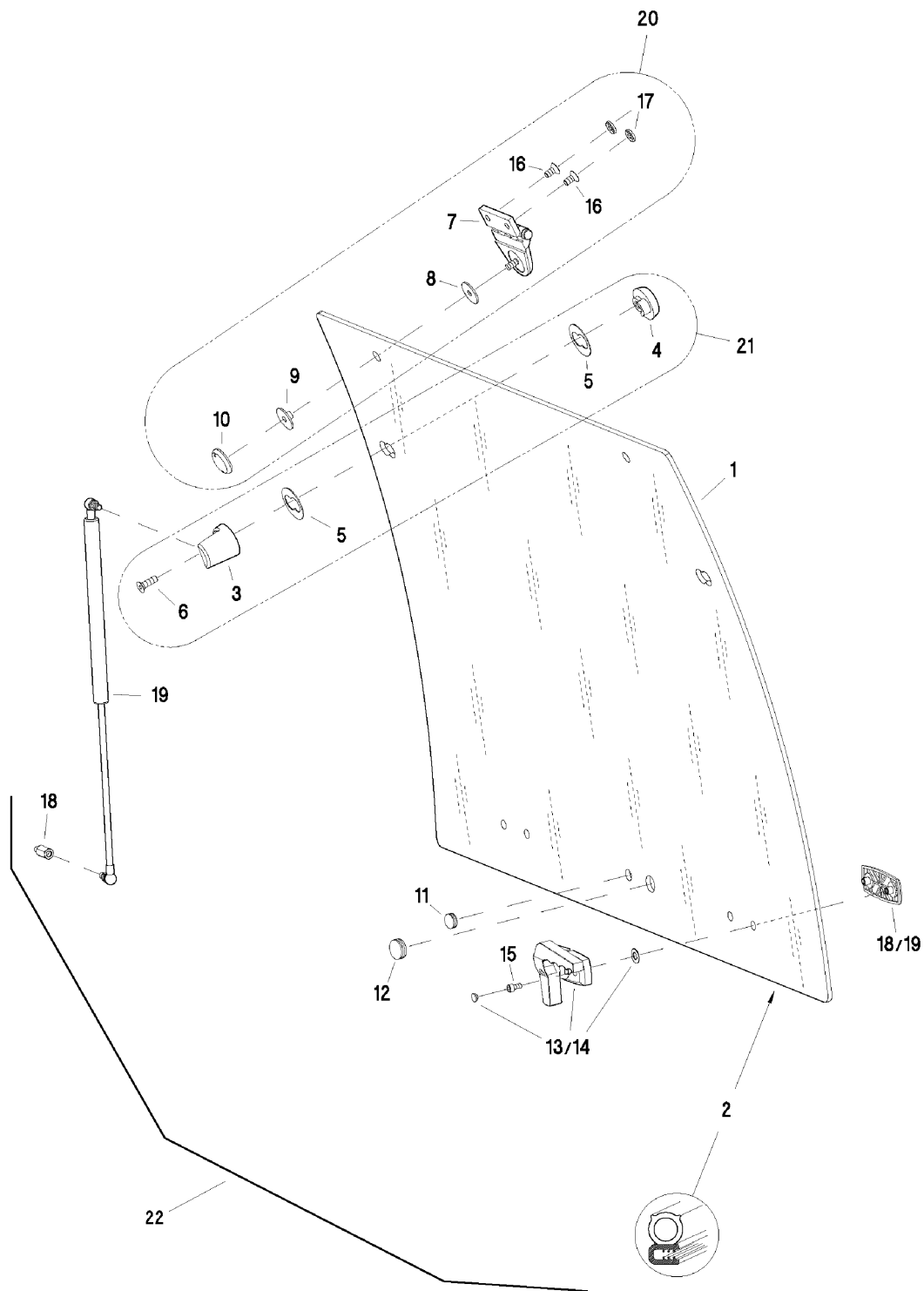

The above parts group applies to the following Mfg. Nos.:

1694401 - Deluxe Hard Snow Cab

## Rear Windshield Group

REF NO	PART NO.	QTY.	DESCRIPTION
1	*	1	Rear glass identical to glass WS
2	1721325SM	4 lfm	Sealing tube profile
3	*	2	Pneumatic spring mounting inside
4	1721335SM	2	Pneumatic spring mounting outside
5	1721431SM	4	Rubber washer
6	*	2	Countersunk head screw M8x25
7	1721336SM	2	PVC hinge complete
8	1721427SM	5	Rubber washer
9	1721428SM	3	Rubber washer with neck
10	1721429SM	2	PA - disk M8
11	1732664SM	1	Blind plug 18mm
12	1721373SM	1	Rubber stopper D=20mm
13	1732705SM	1	Locking device handle left
14	1732706SM	1	Locking device handle right
15	*	4	Socket head screw (hexagon socket)M6x12
16	*	4	Countersunk head screw M8x35
17	1721433SM	4	Cover cap countersunk head screw
18	1721313SM	2	Pneumatic spring sleeve l=22mm 2x M8
19	1732598SM	2	Pneumatic spring 320mm / 150N
20	1721348SM	2	Set of hinges
21	1721349SM	2	Set of pneumatic spring mounting
22	1732596SM	1	Rear glass complete (Includes all ref nos. except ref. nos. 16 & 17)

### Footnotes

NOTE\* Not a serviceable part, must order complete rear glass

---

**The above parts group applies to the following Mfg. Nos.:**

1694401 - Deluxe Hard Snow Cab

## Roof Group

1\4281rg

**NOTE:** Unless noted otherwise,  
use the standard hardware torque  
specification chart.

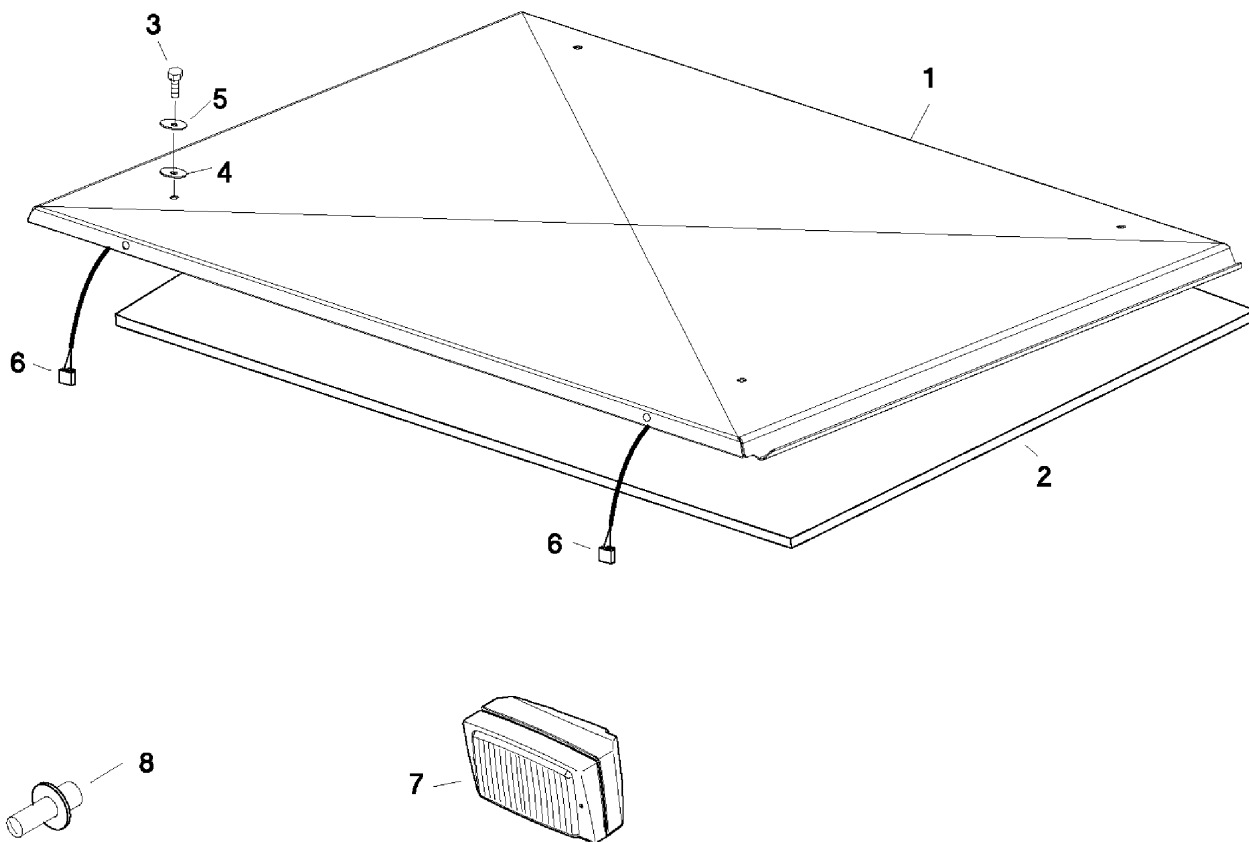

**The above parts group applies to the following Mfg. Nos.:**

1694401 - Deluxe Hard Snow Cab



## Roof Group

---

REF NO	PART NO.	QTY.	DESCRIPTION
1	1732667SM	1	Flat roof
2	1732716SM	1	Material lining fareb 201
3	1732635SM	4	Hexagon head screw M6x16
4	1732660SM	4	Rubber washer 5x20x2
5	1732659SM	4	Auto body washer 6x20x1.5
6	1732683SM	1	Cable loom
7	1732723SM	2	Headlamp H3
8	1732704SM	2	Halogen lamp H3

## Footnotes

---

**The above parts group applies to the following Mfg. Nos.:**

1694401 - Deluxe Hard Snow Cab



# Hardware Identification & Torque Specifications

## Common Hardware Types

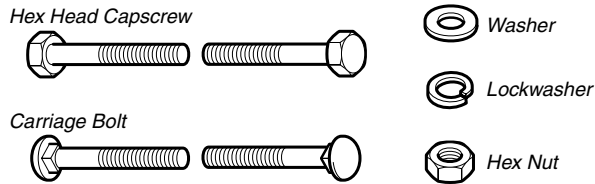

## Standard Hardware Sizing

When a washer or nut is identified as **1/2"**, this is the *Nominal size*, meaning the *inside diameter* is 1/2 inch; if a second number is present it represent the *threads per inch*

When bolt or capscrew is identified as **1/2 - 16 x 2"**, this means the *Nominal size*, or *body diameter* is 1/2 inch; the second number represents the *threads per inch* (16 in this example, and the final number is the *body length* of the bolt or screw (in this example 2 inches long).

**The guides and ruler furnished below are designed to help you select the appropriate hardware and tools.**

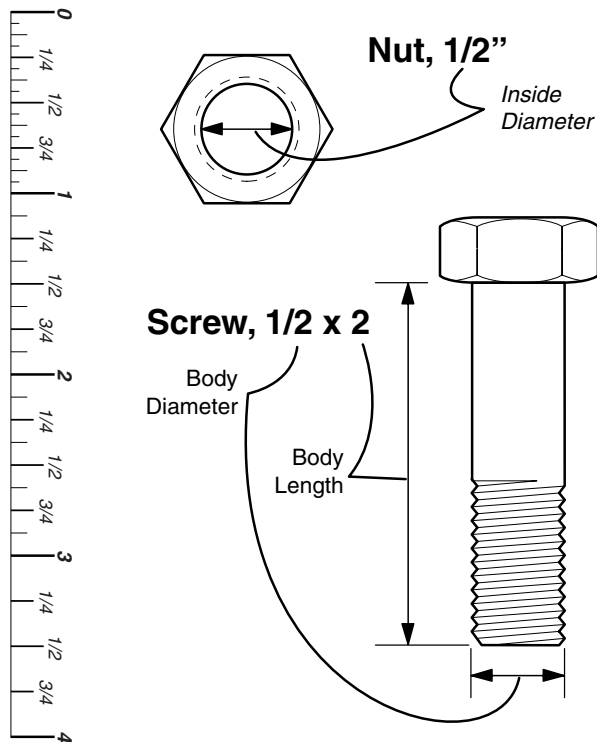

## Torque Specification Chart

FOR STANDARD MACHINE HARDWARE (Tolerance  $\pm 20\%$ )

Hardware Grade	No Marks		SAE Grade 2		SAE Grade 5		SAE Grade 8	
	in/lbs	Nm.	in/lbs	Nm.	in/lbs	Nm.	in/lbs	Nm.
8-32	19	2.1	30	3.4	41	4.6		
8-36	20	2.3	31	3.5	43	4.9		
10-24	27	3.1	43	4.9	60	6.8		
10-32	31	3.5	49	5.5	68	7.7		
1/4-20	66	7.6	8	10.9	12	16.3		
1/4-28	76	8.6	10	13.6	14	19.0		
5/16-18	11	15.0	17	23.1	25	34.0		
5/16-24	12	16.3	19	25.8	27	34.0		
3/8-16	20	27.2	30	40.8	45	61.2		
3/8-24	23	31.3	35	47.6	50	68.0		
7/16-14	30	40.8	50	68.0	70	95.2		
7/16-20	35	47.6	55	74.8	80	108.8		
1/2-13	50	68.0	75	102.0	110	149.6		
1/2-20	55	74.8	90	122.4	120	163.2		
9/16-12	65	88.4	110	149.6	150	204.0		
9/16-18	75	102.0	120	163.2	170	231.2		
5/8-11	90	122.4	150	204.0	220	299.2		
5/8-18	100	136	180	244.8	240	326.4		
3/4-10	160	217.6	260	353.6	386	525.0		
3/4-16	180	244.8	300	408.0	420	571.2		
7/8-9	140	190.4	400	544.0	600	816.0		
7/8-14	155	210.8	440	598.4	660	897.6		
1-8	220	299.2	580	788.8	900	1,244.0		
1-12	240	326.4	640	870.4	1,000	1,360.0		

### NOTES

- These torque values are to be used for all hardware excluding: locknuts, self-tapping screws, thread forming screws, sheet metal screws and socket head setscrews.
- Recommended seating torque values for locknuts:
  - for prevailing torque locknuts - use 65% of grade 5 torques.
  - for flange whizlock nuts and screws - use 135% of grade 5 torques.
- Unless otherwise noted on assembly drawings, all torque values must meet this specification.

## Wrench & Fastener Size Guide



1/4" Bolt or Nut  
Wrench—7/16"

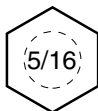

5/16" Bolt or Nut  
Wrench—1/2"

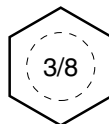

3/8" Bolt or Nut  
Wrench—9/16"



7/16" Bolt or Nut  
Wrench (Bolt)—5/8"  
Wrench (Nut)—11/16"

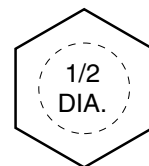

1/2" Bolt or Nut  
Wrench—3/4"

