

shindaiwa®

*HomePro*TM

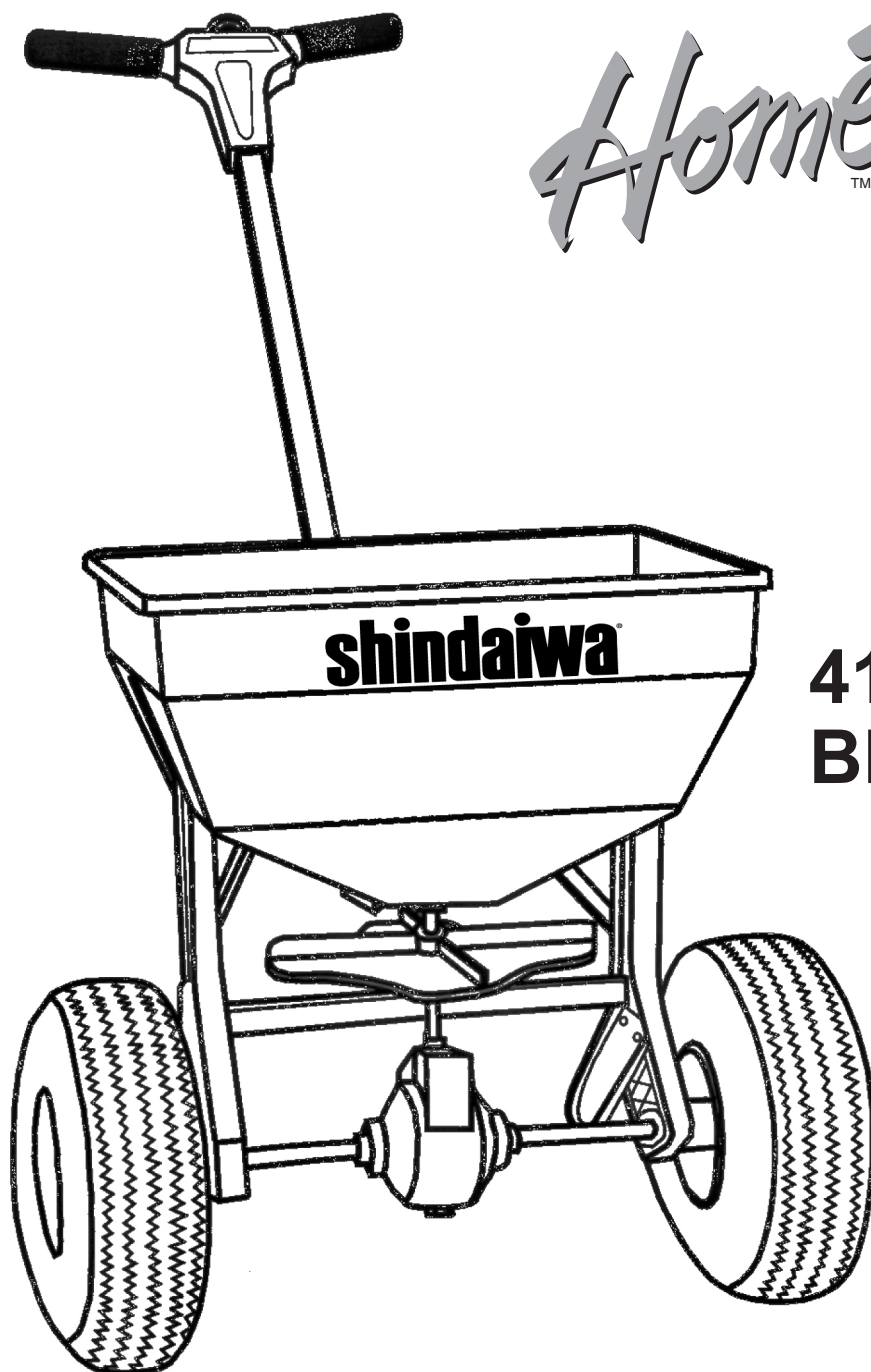

**41RS
BROADCAST**

OWNER'S MANUAL

ASSEMBLY

1. Remove the spreader and components from the carton. Turn spreader upside down. Insert (2) 1/4-20 x 1 1/2" hex bolts through the flattened end of handle brace, frame and leg as shown. Install hex nuts but do not tighten. Repeat on opposite side. Make sure braces are parallel and tighten all nuts.

1/4-20 x 1 1/2"
Hex Bolt

Frame

Leg

1/4-20
Hex
Nut

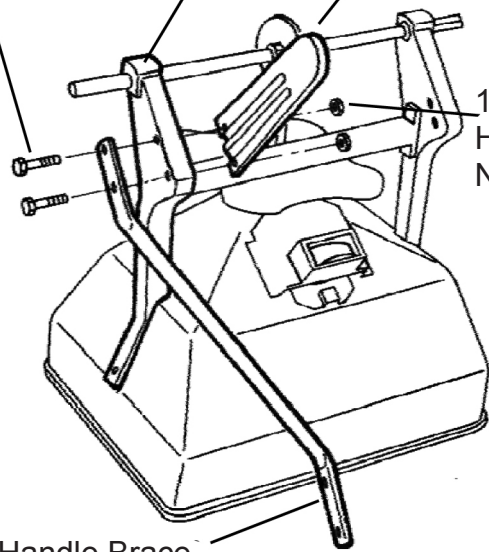

Handle Brace

2. Slide wheels onto axle with the longer portion of the wheel facing the frame. The wheels are identical to ease assembly. Secure free turning wheel with (1) 1/8 x 1" cotter pin and (1) 5/32 x 2" cotter pin on the drive wheel.

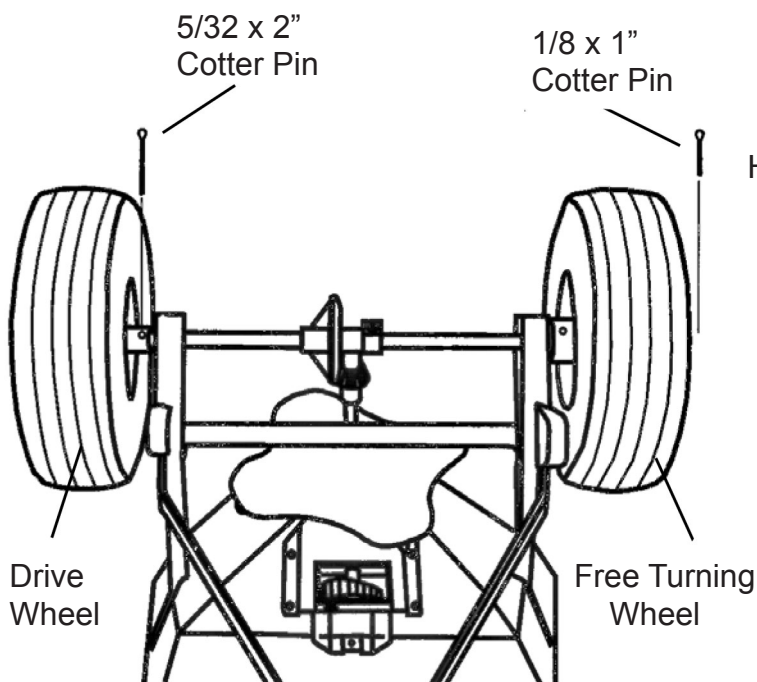

5/32 x 2"
Cotter Pin

1/8 x 1"
Cotter Pin

Drive
Wheel

Free Turning
Wheel

VIEWED FROM REAR OF SPREADER

3. Turn spreader upright and install handle tube between braces. Secure with (2) 1/4-20 x 2" hex bolts and nuts. Tighten handle brace nuts installed in step 1.

Handle Tube

1/4-20 x 2"
Hex Bolt

1/4-20 Hex
Nut

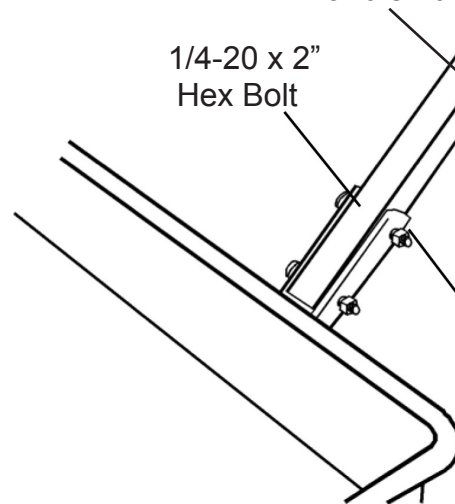

4. Feed control knob/wire through the T-handle until spring touches the round hole. **CAUTION: Do Not Compress Spring At This Time.** Feed wire through the square handle tube. Be sure wire passes above the bolts in the handle brace. Secure T-handle to the tube with (1) 1/4-20 x 2" hex bolt, (2) washers, and (1) hex nut in the bottom hole, and (1) 1/4-20 x 2 1/4" hex bolt, (2) washers, and (1) hex nut in the top hole as shown. Remove caution label and push the thumb release toward the center and push down knob and shutoff spring until knob latches.

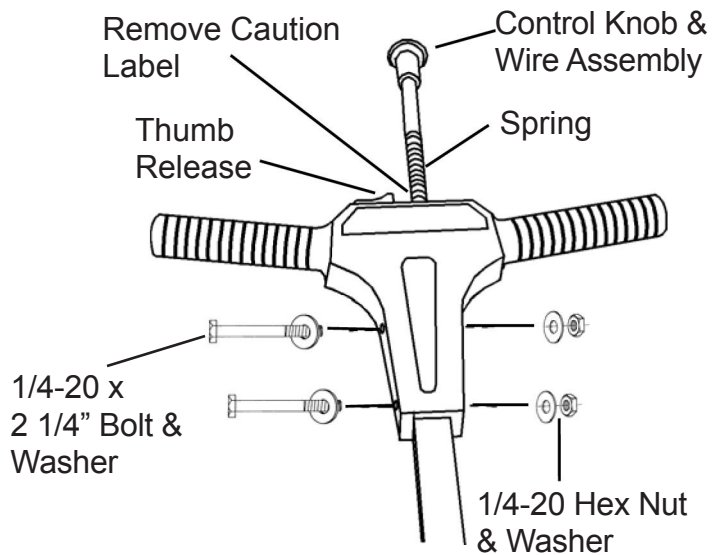

CAUTION: ONCE KNOB IS LATCHED, DO NOT MOVE THUMB RELEASE UNTIL YOU HAVE COMPLETED STEP #5.

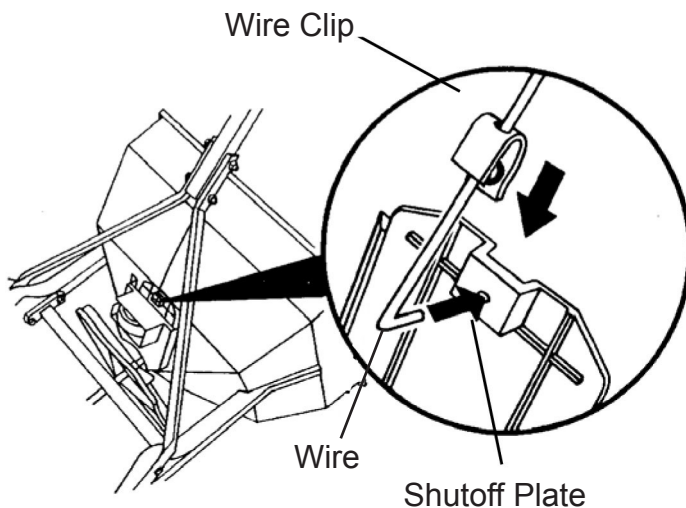

5. Slide wire retaining clip onto wire as shown. Insert wire through hole shutoff plate. Slide wire retaining clip over shutoff plate and wire until the clip locks into place.

6. Install gear cover assembly over gears and secure with (2) #6-32 screws. The 41RS spreader should now be completely assembled and ready for use. Slide handle grips onto handle. Soapy water will ease installation. (Do not use petroleum based products.)

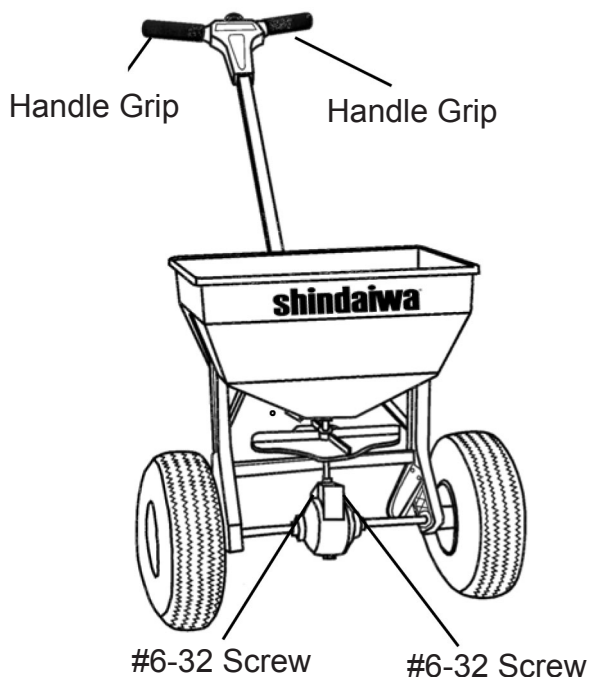

shindaiwa®

OPERATION

1. Check the product package for the rate setting, and recommended swath width. Turn the spreader off by pushing the control knob in. Rotate the rate cam to the proper setting.

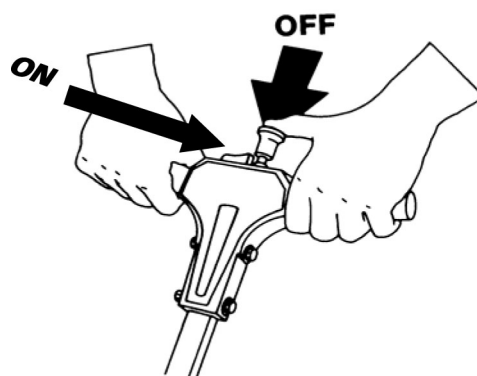

2. Always fill the spreader on the driveway or sidewalk-not on the lawn. Make sure spreader is in the "OFF" position. Empty after each use.

3. Start spreader moving, then open spreader by pushing the thumb release to the "ON" position. Always push spreader, never pull. Push knob down to close spreader.

4. Hold handle so top of spreader is level. Tipping the spreader too far can cause uneven spreading.

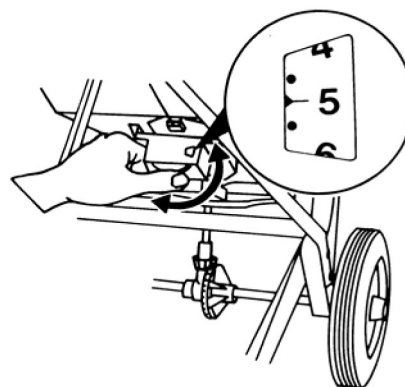

5. The settings and swath widths on the product label are recommended starting points. Always check the delivery rate and pattern on a small area before treating a large area. Actual delivery rate can vary due to weather conditions, operating variables, and condition of the product being applied. See "HOW TO DETERMINE SPREADER SETTING AND SWATH WIDTH" for details.

6. Push spreader 3 1/2 m.p.h. (26 feet in 5 seconds) for full 8' to 10' spread pattern when applying fertilizer products. Apply header strips at each end of area to be treated then space trips across the area as shown.

7. Push spreader at 2 1/2 mph (18 feet in 5 seconds) to reduce width of spread when applying ice melt products to sidewalks.

8. Empty spreader after each use. Return leftover material to its original container.

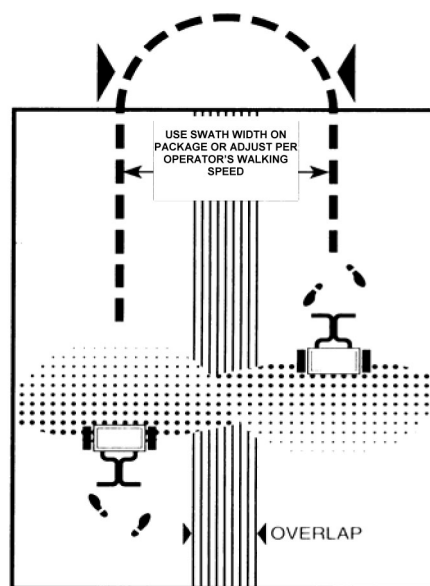

HOW TO DETERMINE SPREADER SETTINGS AND SPREAD WIDTH

Two major factors should be considered when determining correct spreader settings of any product:

1. The product application rate, or the amount of material applied per 1,000 square feet.
2. The effective pattern width, or the actual width in which material is applied. Label settings are a guide and can be affected by numerous factors.

EFFECTIVE PATTERN WIDTH

A simple visual pattern test can be made by operating the spreader over a non-turf area and evaluating the pattern. A more accurate method is to place a row of common, disposable, aluminum cake pans approximately 1 foot on centers. Set the rate cam at a middle setting and make 3 or 4 passes in the same direction as shown. Pour the material collected from each pan into individual bottles of the same size. Set them side by side in order, and visually inspect their volume. The effective pattern width is the distance out from the spreader to a point where the amount of material is 1/2 the average amount in the center pans. This distance is multiplied by 2 to achieve the total effective pattern width.

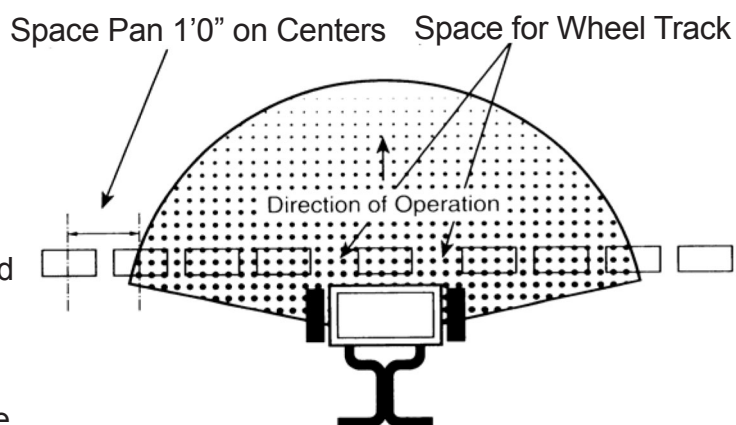

APPLICATION RATE

Knowing the effective pattern width (for example, 10 feet), measure a distance equal to 100 square feet (10' x 10' swath width). Determine the product coverage is pounds/ 100 sq. ft. by the recommended square foot coverage (add two zeroes to the weight of the bag).

EXAMPLE: Product weight: 25 lbs. sq. ft.
coverage: 5,000 sq. ft. 2500 lbs. - 5,000
sq. ft. = .5 lbs. / 100 sq. ft.

Weigh out between 15 to 20 lbs. of material and spread over the 100 sq. ft. area. Weigh remaining material left in hopper and adjust rate setting as required. Repeat test until application rate is correct.





shindaiwa[®]

RATE SETTING CONVERSION

The following provides approximate **shindaiwa**® 41RS settings for those units listed.

Shindaiwa 41RS Setting	2	3	4	5	6	7	8	9	10	11	12	13	14	15	16	17	18
Scott Speedy Green Setting	2	3	4	5	6	7	8	9	10	11	12	13	14	15	16	17	18
Prizelawn BF1 / BF1SS Setting	E	I	K	M	O	R	W	Z	—	—	—	—	—	—	—	—	—
Lesco #029600	D	—	H	—	K	M	Q	S	—	—	—	—	—	—	—	—	—
Scotts R8A/ SR-1 Setting	G	K	M	O	Q	T	—	Z	—	—	—	—	—	—	—	—	—
Earthway 2200/2400 Setting	10	—	15	17	19	22	26	30	—	—	—	—	—	—	—	—	—
Spyker 76/78-2 Setting	4	—	5	6	7	8	9	10	—	—	—	—	—	—	—	—	—

The following provides approximate **shindaiwa**® 41RS settings when only the product weight, square foot coverage, and visual inspection of the material is available.

FERTILIZER PARTICLE SIZE		BAG RATE Pounds of fertilizer used per 1,000 sq. ft. of coverage	APPROX. SETTING	SPREAD WIDTH
Large, heavy particles		5	3 1/2	8
		10	4	8
		15	4 1/2	8
Medium-mixed particles		5	2 1/2	8
		10	3 1/2	8
		15	4	8
Small particles (nitrogen)		1	2	8
		2	2 1/2	8
		3	3	8
Mixed size particles-some fines		5	3	6
		10	3 1/2	6
		15	4	6
Light weight particles		5	2	4
		10	2 1/2	To
		15	3	6

Conversions should be used as guidelines for establishing proper rate settings. To obtain the most accurate application rate, follow the procedures described in the Effective Pattern Width and Application Rate sections. The settings shown here are only approximations and will vary due to physical characteristics of the product, walking speed, turf condition, humidity, etc. Warranty and guarantees of actual coverage or uniformity are neither expressed nor implied.

shindaiwa®

MAINTENANCE

1. Never store unused material in spreader. Return unused product to its original container.
2. Wash spreader thoroughly after each use and dry completely in sun or heated area.
3. Oil the axle bearings, impeller shaft bearing in hopper, control knob in T-handle.
4. Remove gear cover and wash gears thoroughly. Oil all bearing areas and face of gear teeth. Re-install gear cover.
5. Gear mesh should be checked on a regular basis during high use periods. Clearance between the axle gear and pinion gear should be minimal but not tight. If adjustment is necessary, loosen axle collar set screw and hold gears together. Slide axle collar against the gear support and tighten axle collar set screw. Spin drive wheel. Gears should run freely and smoothly.
6. Impeller surface should be cleaned periodically to remove build-up of product. Build-up can cause the spread pattern to change.
7. Tire pressure should be 20-25 PSI.

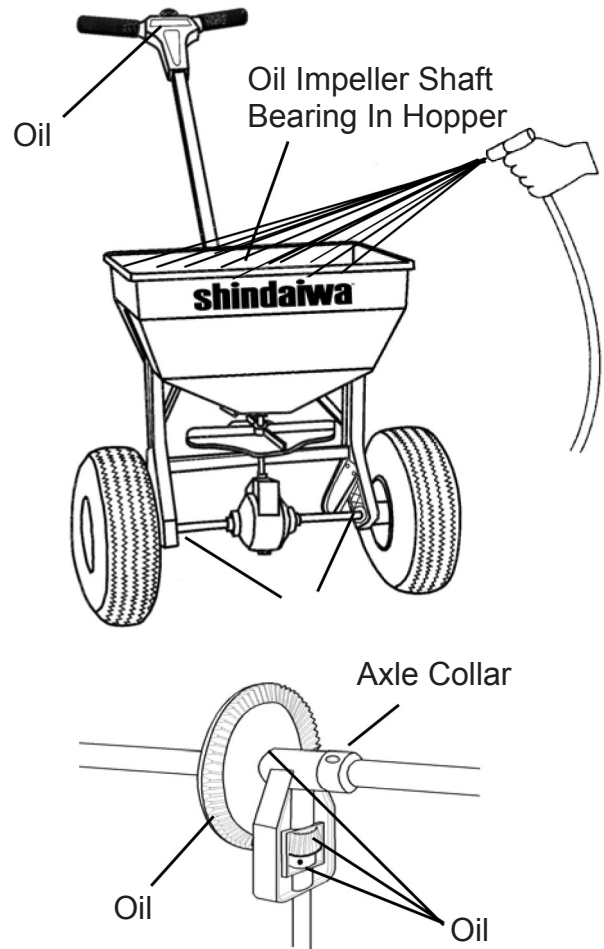

WARRANTY

Shindaiwa Inc. manufactures its products to superior standards of quality to ensure customers obtain the highest level of satisfaction. In keeping with this goal, Shindaiwa Inc. warrants the unit to the original purchaser as follows:

WARRANTY PERIOD

One year from the delivery date to the original purchaser for consumer and commercial applications. 90 days for rental applications.

WARRANTY ADMINISTRATION

Within the covered warranty period, Shindaiwa Inc. will, at their option, repair or replace any defect in material or workmanship, without charge for parts or labor, if this product is presented at an authorized Shindaiwa dealer.

WARRANTY EXCLUSIONS AND LIMITATIONS

Shindaiwa Inc. assumes no responsibility for damages, loss, or injury resulting from:

- Normal wear and tear
- Misuse or neglect
- Modifications to or removal of original component parts

The warranty is limited to the terms stated herein. Shindaiwa Inc. disclaims all liability for incidental or consequential damages. Some states do not allow the exclusion of incidental or consequential damages, so these limitations may not apply to you.

This warranty give you specific legal rights, and you may also have other rights which may vary from state to state.

Shindaiwa reserves the right to change the design or specifications of this product without obligation to modify previously manufactured products.

OWNER'S RESPONSIBILITIES

The owner of the unit must demonstrate reasonable care in the use, maintenance, and storage of this Shindaiwa product. If a warrantable failure should occur, the owner must deliver the product to an authorized Shindaiwa servicing dealer for correction. All residual chemicals must be flushed from the tank prior to delivery.

Unidentified chemicals left in the tank can pose a serious health threat to anyone servicing the unit and unaware of its presence!

To obtain warranty service, proof of purchase must be presented to the authorized Shindaiwa servicing dealer when the product is presented for repairs.

Proof of purchase must include date of purchase and the name and address of the selling dealer.

shindaiwa®

Parts List for SHINDAIWA MODEL 41RS

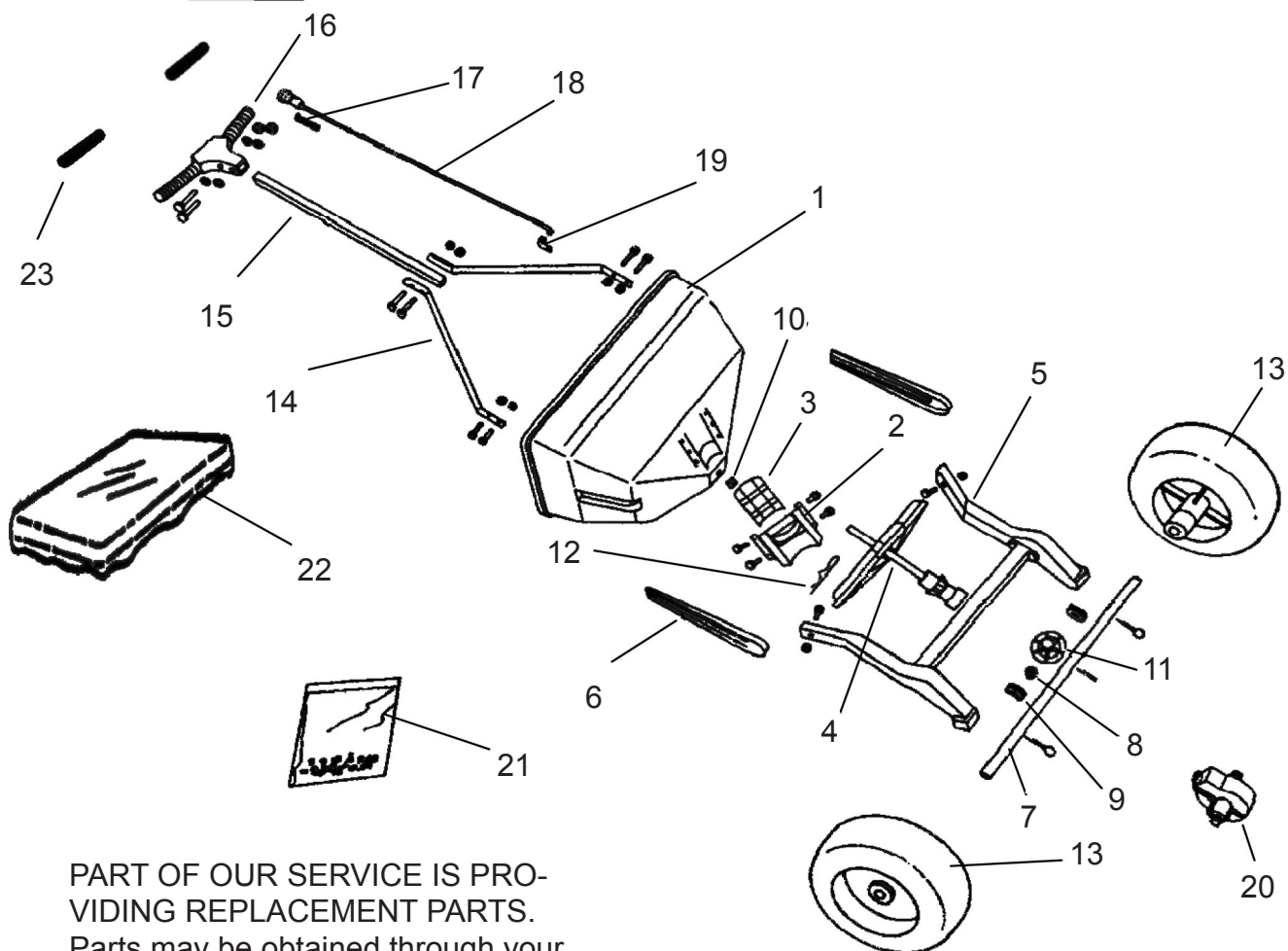

PART OF OUR SERVICE IS PROVIDING REPLACEMENT PARTS. Parts may be obtained through your local distributor. be sure to give:

1. SPREADER MODEL NUMBER
2. SPREADER NAME
3. PART NUMBER
4. NAME OF PART AS SHOWN

shindaiwa®

11975 SW Herman Rd.
Tualatin, Or. 97062
503-692-3070 Fax 503-692-6696
www.shindaiwa.com
P / N 82010

Key No.	Description	Part No.	Key No.	Description	Part No.
1	Hopper Ass'y-includes #2 & 3	15845	13	Drive & Free Turning Wheel	14939-1
2	Rate Cam & Chute Assembly	14455-1	14	Handle Braces (2)	13613-1
3	Shutoff Plate	14454-1	15	Handle Tube	14513-1
4	Impeller Assembly	15849	16	T-Handle Assembly	13634-2
5	Frame Assembly	15837	17	Control Knob Spring	14462
6	Legs (2)	13619-1	18	Control Knob & Wire Ass'y	13640-1
7	Axle	15842	19	Wire Retaining Clip	13643-1
8	Axle Collar	13362	20	Gear Cover Assembly	13623-1
9	Axle Bushings (2)	12696	21	Fastener Package	15880
10	Impeller Shaft Bearing	15833	22	Hopper Cover	15209
11	Axle Gear	13625-1	23	Handle Grip (2)	15264
12	Agitator	15866			

shindaiwa®