

BUNN®

TW

TWF

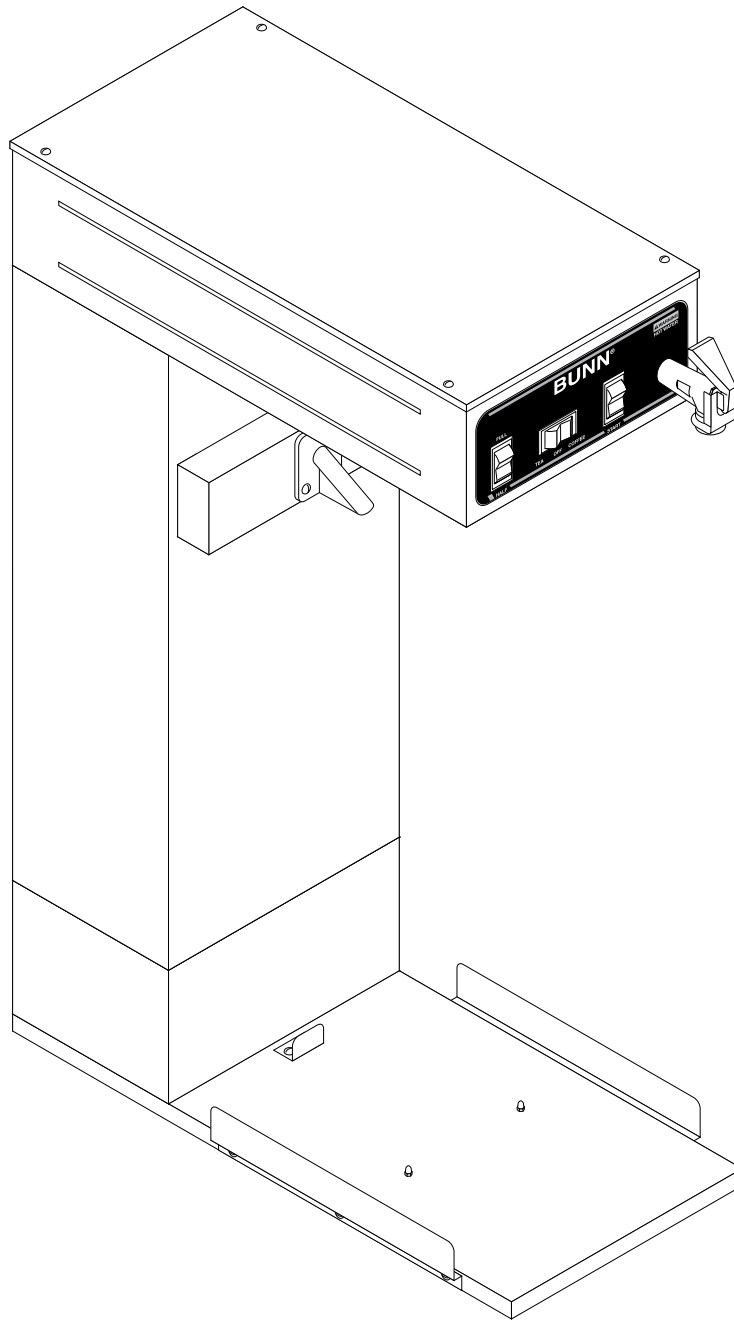

OPERATING & SERVICE MANUAL

BUNN-O-MATIC CORPORATION

POST OFFICE BOX 3227

SPRINGFIELD, ILLINOIS 62708-3227

TELEPHONE: (217) 529-6601 FAX: (217) 529-6644

CONTENTS

Introduction	2
Warranty	2
User Notices	3
Electrical Requirements	4
Plumbing Requirements	4
Initial Set-Up	5
Adjusting Brew Controls	6
Cleaning	6
Operating Controls	7
Tea Brewing	7
Troubleshooting	8
Service	14
Wiring Diagram	31

INTRODUCTION

This equipment will brew a half-gallon batch of hot coffee into an airpot server or dispenser and a three-gallon batch of fresh tea into a dispenser and dispense at approximately room temperature to conserve ice. The brewer is only for indoor use on a sturdy counter or shelf.

WARRANTY

Bunn-O-Matic Corp. ("Bunn") warrants the equipment manufactured by it to be commercially free from defects in material and workmanship existing at the time of manufacture and appearing within one year from the date of installation. In addition:

- 1.) Bunn warrants electronic circuit and/or control boards to be commercially free from defects in material and workmanship for two years from the date of installation.
- 2.) Bunn warrants the compressor on refrigeration equipment to be commercially free from defects in material and workmanship for two years from the date of installation.
- 3.) Bunn warrants that the grinding burrs on coffee grinding equipment will grind coffee to meet original factory screen sieve analysis for three years from date of installation or for 30,000 pounds of coffee, whichever comes first.

This warranty does not apply to any equipment, component or part that was not manufactured by Bunn or that, in Bunn's judgement, has been affected by misuse, neglect, alteration, improper installation or operation, improper maintenance or repair, damage or casualty.

THE FOREGOING WARRANTY IS EXCLUSIVE AND IS IN LIEU OF ANY OTHER WARRANTY, WRITTEN OR ORAL, EXPRESS OR IMPLIED, INCLUDING, BUT NOT LIMITED TO, ANY IMPLIED WARRANTY OF EITHER MERCHANTABILITY OR FITNESS FOR A PARTICULAR PURPOSE. The agents, dealers or employees of Bunn are not authorized to make modifications to this warranty or to make additional warranties that are binding on Bunn. Accordingly, statements by such individuals, whether oral or written, do not constitute warranties and should not be relied upon.

The Buyer shall give Bunn prompt notice of any claim to be made under this warranty by telephone at (217) 529-6601 or by writing to Post Office Box 3227, Springfield, Illinois, 62708-3227. If requested by Bunn, the Buyer shall ship the defective equipment prepaid to an authorized Bunn service location. If Bunn determines, in its sole discretion, that the equipment does not conform to the warranty, Bunn shall repair the equipment with no charge for parts during the warranty period and no charge for labor by a Bunn Authorized Service Representative during the warranty period. If Bunn determines that repair is not feasible, Bunn shall, at its sole option, replace the equipment or refund the purchase price for the equipment.

THE BUYER'S REMEDY AGAINST BUNN FOR THE BREACH OF ANY OBLIGATION ARISING OUT OF THE SALE OF THIS EQUIPMENT, WHETHER DERIVED FROM WARRANTY OR OTHERWISE, SHALL BE LIMITED, AS SPECIFIED HEREIN, TO REPAIR OR, AT BUNN'S SOLE OPTION, REPLACEMENT OR REFUND.

In no event shall Bunn be liable for any other damage or loss, including, but not limited to, lost profits, lost sales, loss of use of equipment, claims of Buyer's customers, cost of capital, cost of down time, cost of substitute equipment, facilities or services, or any other special, incidental or consequential damages.

ELECTRICAL REQUIREMENTS

CAUTION - The brewer must be disconnected from the power source until specified in *Initial Set-Up*.

120V model brewers require 2-wire, grounded service rated 120 volt ac, 15 amp, single phase, 60 Hz.

120/208V model brewers require 3-wire, grounded service rated 120/208 volt, 20 amp, single phase, 60 Hz.

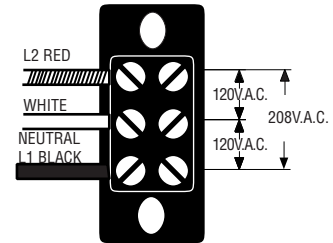

Electrical Hook-Up

CAUTION – Improper electrical installation will damage electronic components.

1. An electrician must provide electrical service as specified.
2. Remove the top lid and rotate the control thermostat knob fully counterclockwise to the "OFF" position.
3. a) 120V brewers have an attached cordset. Plug in the brewer and proceed to #6.
b) 120/208V brewers, feed the cord through the strain relief at the rear of the brewer and connect it to the terminal block.
4. Using a voltmeter, check the voltage and color coding of each conductor at the power source.
5. Connect the brewer to the power source and verify the voltage at the terminal block.
6. If plumbing is to be hooked up later be sure the brewer is disconnected from the power source. If plumbing has been hooked up, the brewer is ready for *Initial Set-Up*.

PLUMBING REQUIREMENTS

These brewers must be connected to a cold water system with operating pressure between 20 (128) and 90 psi (620 kPa) from a ½" or larger supply line. A shut-off valve should be installed in the line before the brewer. Install a regulator in the line when pressure is greater than 90 psi (620 kPa) to reduce it to 50 psi (345 kPa). The water inlet fitting is ¼" flare.

NOTE - Bunn-O-Matic recommends ¼" copper tubing for installations of less than 25 feet and ⅜" for more than 25 feet from the ½" water supply line. A tight coil of copper tubing in the water line will facilitate moving the brewer to clean the countertop. Bunn-O-Matic does not recommend the use of a saddle valve to install the brewer. The size and shape of the hole made in the supply line by this type of device may restrict water flow.

1. Remove the shipping cap(s) from the bulkhead fitting(s) on the rear of the brewer.
2. Attach the flare fitting from the short piece of tubing on the strainer/flow control (supplied) to the water inlet fitting(s) at the rear of the brewer.
3. Flush the water line and securely attach it to the flare fitting on the tee or strainer/flow control.
4. Turn on the water supply.
5. On brewers with a faucet, place an empty vessel beneath the faucet and lift the handle until water is dispensed.

This equipment must be installed to comply with the Basic Plumbing Code of the Building Officials and Code Administrators International, Inc. (BOCA) and the Food Service Sanitation Manual of the Food and Drug Administration (FDA).

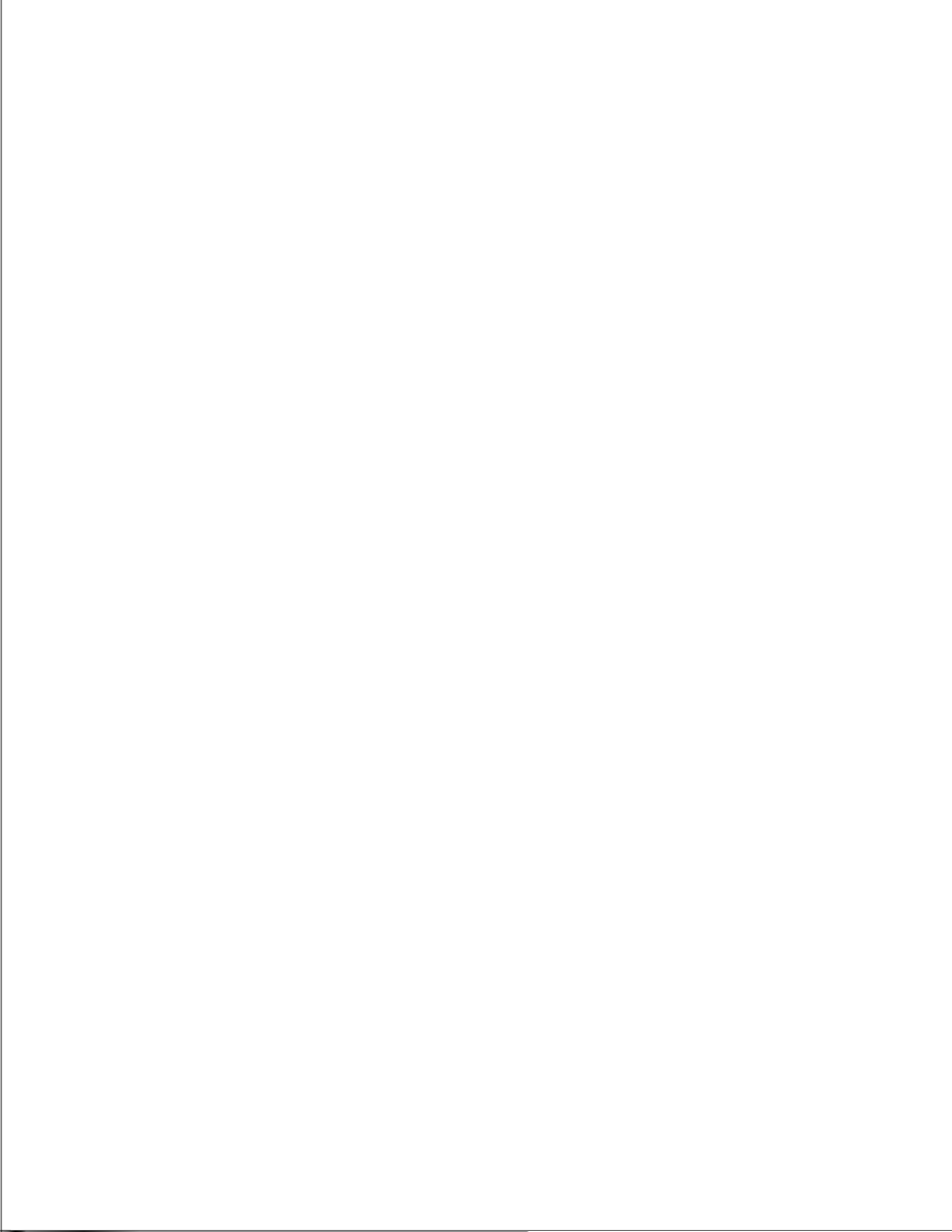

INITIAL SET-UP (cont.)

ADJUSTING BREW VOLUMES

CAUTION - Disconnect the power source from the brewer prior to the removal of any panel for the replacement or adjustment of any component.

NOTE: Prior to setting or modifying batch sizes, check that the brewer is connected to water supply, the tank is properly filled, and a funnel and server are in place.

1. **Modifying batch sizes.** To modify a batch volume, first check that the SET/LOCK switch is in the “SET” position on the circuit board.

To increase a batch size. Press and hold the START or BREW switch until three clicks are heard. Release the switch (Failure to release the switch within two seconds after the third click causes the volume setting to be aborted and previous volume setting will remain in memory) and press it again one or more times. Each time the switch is pressed, two seconds are added to the brew time period. Allow the brew cycle to finish in order to verify that the desired volume has been achieved.

To decrease a batch size. Press and release the START or BREW switch once for every two-second interval to be removed from the total brew time period; then immediately press and hold down the START or BREW switch until three clicks are heard. Release the switch. (Failure to release the switch within two seconds after the third click causes the volume setting to be aborted and previous volume setting will remain in memory). Allow the brew cycle to finish in order to verify that the desired volume has been achieved.

2. **Setting batch sizes.** To set a batch volume, first check that the SET/LOCK switch is in the “SET” position on the circuit board. Press and hold the START or BREW switch until three distinct clicks are heard, and then release the switch. (Failure to release the switch within two seconds after the third click causes the volume setting to be aborted and previous volume setting will remain in memory). View the level of the liquid being dispensed. When the desired level is reached, turn the ON/OFF switch to “OFF” (lower). The brewer remembers this volume and will continue to brew batches of this size until the volume setting procedure is repeated.

NOTE: When brewing coffee, batch volumes will decrease due to absorption by the coffee grounds.

3. **Setting programming disable feature.** If it becomes necessary to prevent anyone from changing brew times once programmed, you can set the SET/LOCK switch to the “LOCK” position. This will prevent any programming to be done until switch is once again placed in the “SET” position.

CLEANING

CAUTION – Do not keep brewed tea overnight. Clean and sanitize your iced tea dispenser **daily**

1. Remove and thoroughly clean the brew funnel. The funnel tip and screen must be free from any tea particles or residue. Reassemble the funnel.
2. Unplug the brewer. Remove and thoroughly rinse the sprayhead. The holes must be open and clear of any mineral deposits. Wipe the sprayhead panel clean with a damp cloth.
3. Insert the delimiting spring into the sprayhead fitting until no more than one inch is visible and move it in and out 5 or 6 times. Insert the spring into the airvent hole in the sprayhead panel and move it in and out 5 or 6 times. Reattach the sprayhead.
4. Wash the entire outside surface of the brewer with a clean damp cloth.

OPERATING CONTROLS

A. TEA/OFF/COFFEE Switch

TEA– Placing the switch in the left position allows the start switch to activate a timed brew cycle delivering .5 gallon of tea concentrate and 2.5 gallons of dilution water into the dispenser.

OFF – Placing the switch in the center position stops the brew cycle. Stopping a brew cycle after it has started will not stop the flow of water into the funnel until the tank syphons down to its level. The switch should always be placed in this position after a brew cycle and whenever the brewer is unattended.

COFFEE– Placing the switch in the right position allows the start switch to activate a timed brew cycle delivering .5 gallon of hot coffee into an airpot dispenser.

B. Start Switch

Starts a brew cycle when the TEA/OFF/COFFEE switch is in either the “TEA” or “COFFEE” position.

BREWING

1. Begin brewing with a clean empty brew funnel and dispenser. (Be sure the server lid doesn't interfere with the flow of dilution water)
2. Insert a BUNN® filter into the funnel.
3. Pour the packet of fresh tea leaves or coffee into the filter. Approximately 4 ounces is recommended for tea.
4. Level the bed of tea leaves or coffee by gently shaking.
5. Slide the funnel into the funnel rails until it stops.
6. Place the TEA/OFF/COFFEE switch in the desired position.
7. Momentarily press the start switch.

CAUTION – The funnel contains hot liquid. Remove funnel slowly.

8. Carefully remove the brew funnel and discard its contents after liquid stops flowing from the funnel.
9. Place the TEA/OFF/COFFEE switch in the “OFF” position to prevent a false start.

TROUBLESHOOTING

A troubleshooting guide is provided to suggest probable causes and remedies for the most likely problems encountered. If the problem remains after exhausting the troubleshooting steps, contact the Bunn-O-Matic Technical Service Department.

- Inspection, testing, and repair of electrical equipment should be performed only by qualified service personnel.
- All electronic components have 120 volt ac and low voltage dc potential on their terminals. Shorting of terminals or the application of external voltages may result in board failure.
- Intermittent operation of electronic circuit boards is unlikely. Board failure will normally be permanent. If an intermittent condition is encountered, the cause will likely be a switch contact or a loose connection at a terminal or crimp.
- Solenoid removal requires interrupting the water supply to the valve. Damage may result if solenoids are energized for more than ten minutes without a supply of water.
- The use of two wrenches is recommended whenever plumbing fittings are tightened or loosened. This will help to avoid twists and kinks in the tubing.
- Make certain that all plumbing connections are sealed and electrical connections tight and isolated.
- This brewer is heated at all times. Keep away from combustibles.

WARNING –

- Exercise extreme caution when servicing electrical equipment.
- Unplug the brewer when servicing, except when electrical tests are specified.
- Follow recommended service procedures
- Replace all protective shields or safety notices

Problem	Probable Cause	Remedy
Brew cycle(s) will not start	1. No water	Water lines and valves to the brewer must be open.
	2. No power or incorrect voltage to the brewer	Check circuit breakers or fuses.
	3. External Strainer/ Flow Control (.750 GPM)	(A) Direction of flow arrow must be pointing towards the brewer.
		(B) Remove the strainer/flow control and check for obstructions. Clear or replace.
	4. TEA/OFF/COFFEE Switch	Refer to <i>Service</i> - TEA/OFF/COFFEE Switch for testing. See page 26
5. Start Switch	Refer to <i>Service</i> - Start Switch for testing procedures. See page 27	

TROUBLESHOOTING (cont.)

PROBLEM

Brew cycle(s) will not start (cont.)

PROBABLE CAUSE

6. Brew Timer
 - A) Iced Tea

 - B) Hot Coffee

7. Brew Solenoid Valve
 - A) Iced Tea

 - B) Hot Coffee

8. Internal Flow control (.195 GPM)
(Hot Coffee Only)

REMEDY

Refer to *Service* - Brew Timer (Iced Tea) for testing procedures. See page 20 or 21

Refer to *Service* - Brew Timer (Hot Coffee) for testing procedures. See page 17 or 18

Refer to *Service* - Brew Solenoid Valve (Iced Tea) for testing procedures. See page 16

Refer to *Service*- Brew Solenoid Valve (Hot Coffee) for testing procedures. See page 15

(A) Direction of flow arrow must be pointing towards brewer.

(B) Remove the flow control and check for obstructions. Clear or replace.

Brew water is not hot

1. Limit Thermostat
CAUTION - Do not eliminate or bypass limit thermostat. Use only BOM replacement part #29329.1000

Refer to *Service* - Limit Thermostat for testing procedures. See page 25

2. Thermal Fuse
CAUTION - Do not eliminate or bypass thermal fuse.

Refer to *Service* - Thermal fuse for testing procedures. See page 29

3. Control Thermostat

Refer to *Service* - Control Thermostat for testing procedures. See page 23

4. Tank Heater

Refer to *Service* - Tank Heater for testing procedures. See page 28

Dilution (Iced Tea) cycle will not start

1. TEA/OFF/COFFEE Switch

Refer to *Service* - TEA/OFF/COFFEE Switch for testing procedures. See page 26

TROUBLESHOOTING (cont.)

PROBLEM

Dilution (Iced Tea) cycle will not start (cont.)

PROBABLE CAUSE

2. Start Switch

3. Brew Timer (Iced Tea)

4. Brew Solenoid Valve (Iced Tea)

5. Dilution Solenoid Valve

REMEDY

Refer to *Service* - Start Switch for testing procedures. See page 27

Refer to *Service*- Brew Timer (Iced Tea) for testing procedures. See page 20 or 21

Refer to *Service* - Brew Solenoid Valve (Iced Tea) for testing procedures. See page 16

Refer to *Service* - Dilution Solenoid Valve for testing procedures. See page 24

Inconsistent beverage level in dispenser (Hot Coffee)

1. Internal Flow Control (.195 GPM)

(A) Direction of flow arrow must be pointing towards the brewer.

(B) Remove the flow control and check for obstruction. Clear or replace.

2. Syphon System

The brewer must be level or slightly lower in front to syphon properly.

3. Lime Build-up

CAUTION - Tank and tank components should be delimed regularly depending on local water conditions. Excessive mineral build-up on stainless steel surfaces can initiate corrosive reactions resulting in serious leaks.

Inspect the tank assembly for excessive lime deposits. Delime as required.

4. Water Pressure

The water pressure to the brewer must be at least 20 psi (128 kPa).

Consistently high or low beverage level in the dispenser

1. Brew Timer

With the TEA/OFF/COFFEE switch in the "TEA" position adjust the needle valve to achieve the recommended 76 oz of concentrate then the timer to achieve a total of 396 oz for each three-gallon brew cycle.

TROUBLESHOOTING (cont.)

PROBLEM

PROBABLE CAUSE

REMEDY

Consistently high or low beverage level in the dispenser. (cont.)

2. External Strainer/Flow Control (.750 GPM)

(A) Direction of flow arrow must be pointing towards brewer.

(B) Remove the strainer/flow control and check for obstructions. Clear or replace.

Spitting or excessive steaming

1. Lime Build-up
CAUTION - Tank and tank components should be delimed regularly depending on local water conditions. Excessive mineral build-up on stainless steel surfaces can initiate corrosive reactions resulting in serious leaks.

Inspect tank assembly for excessive lime deposits. Delime as required.

2. Control Thermostat

Refer to *Service* - Control Thermostat for testing procedures. See page 23

Drip-out time too long

1. Funnel Tip

The brew funnel should be cleaned thoroughly before each brew cycle to lessen the chance of tea leaf particles clogging the drip-out tip.

Dripping from sprayhead

1. Syphon System

The brewer must be level or slightly lower in front to syphon properly.

2. Lime Build-up
CAUTION - Tank and tank components should be delimed regularly depending on local water conditions. Excessive mineral build-up on stainless steel surfaces can initiate corrosive reactions resulting in serious leaks.

Inspect the tank assembly for excessive lime deposits. Delime as required.

3. Brew Solenoid Valve
A) Iced Tea

Refer to *Service* - Brew Solenoid Valve (Iced Tea) for testing procedures. See page 16

B) Hot Coffee

Refer to *Service*- Brew Solenoid Valve (Hot Coffee) for testing procedures. See Page 15

TROUBLESHOOTING (cont.)

PROBLEM

PROBABLE CAUSE

REMEDY

Water flows into tank continuously (TEA/OFF/COFFEE Switch in the "TEA or "COFFEE" position)

1. Brew Timer
 - A) Iced Tea
 - B) Hot Coffee

Refer to *Service* - Brew Timer (Iced Tea) for testing procedures. See page 20 or 21

Refer to *Service*- Brew Timer (Hot Coffee) for testing procedures. See page 17 or 18

Water flows into tank continuously (TEA/OFF/COFFEE Switch in the "OFF" position)

1. Brew Solenoid Valve
 - A) Iced Tea
 - B) Hot Coffee

Refer to *Service* - Brew Solenoid Valve (Iced Tea) for testing procedures. See page 16

Refer to *Service*- Brew Solenoid Valve (Hot Coffee) for testing procedures. See page 15

Beverage overflows dispenser

1. Dispenser
2. Brew Timer
 - A) Iced Tea
 - B) Hot Coffee
3. Brew Solenoid Valve
 - A) Iced Tea
 - B) Hot Coffee
4. Dilution Solenoid Valve

The dispenser must be completely empty before starting a brew cycle.

Refer to *Service* - Brew Timer (Iced Tea) for testing procedures. See page 20 or 21

Refer to *Service*- Brew Timer (Hot Coffee) for testing procedures. See page 17 or 18

Remove the Iced Tea Brew Solenoid Valve and clean any obstruction. Rebuild or replace the valve if necessary. See page 16

Remove the Hot Coffee Brew Solenoid Valve and clean any obstruction. Rebuild or replace the valve if necessary. See page 15

Refer to *Service* - Dilution Solenoid Valve for testing procedures. See page 24

TROUBLESHOOTING (cont.)

PROBLEM	PROBABLE CAUSE	REMEDY
Weak beverage	1. Filter Type	BUNN® paper filters must be used for proper extraction.
	2. Tea or Coffee	A sufficient quantity of fresh tea leaves or coffee should be used for proper extraction.
	3. Sprayhead	A six-hole (or seven-hole for Models with 90 oz concentrate option) stainless steel sprayhead must be used for proper extraction.
	4. Funnel Loading	The BUNN® paper filter must be centered in the funnel and the bed of tea leaves leveled by gentle shaking.
	5. Water Temperature	Place an empty funnel on an empty dispenser beneath the sprayhead. Initiate a brew cycle and check the water temperature immediately below the sprayhead with a thermometer. The reading should not be less than 200°F(93°C). Adjust the control thermostat to increase the water temperature. Replace if necessary.
Dry tea leaves remain in the funnel	1. Funnel Loading	The BUNN® paper filter must be centered in the funnel and the bed of grounds leveled by gently shaking.
Brewer is making unusual noises	1. Solenoid(s)	The nut on the solenoid(s) must be tight or it will vibrate during operation.
	2. Plumbing Lines	Plumbing lines should not be resting on the counter top.
	3. Water Supply	(A) The brewer must be connected to a cold water line. (B) Water pressure to the brewer must not exceed 90 psi(620 kPa). Install a regulator if necessary to lower the working pressure to approximately 50 psi(345 kPa).
	4. Tank Heater	Remove and clean lime off the tank heater. See page 28

SERVICE

This section provides procedures for testing and replacing various major components used in this brewer should service become necessary. Refer to *Troubleshooting* for assistance in determining the cause of any problem.

WARNING - Inspection, testing, and repair of electrical equipment should be performed only by qualified service personnel. The brewer should be disconnected from the power source when servicing, except when electrical tests are required and the test procedure specifically states to plug-in the brewer.

COMPONENT ACCESS

WARNING - Disconnect the brewer from the power source before the removal of any panel or the replacement of any component.

All components are accessible by the removal of the top cover and rear inspection panel.

The top cover is attached with four #6-32 screws. Removal of the top cover will allow access to TEA/OFF/COFFEE switch, start switch, brew timers, control thermostat, limit thermostat, thermal fuse and tank heater.

The rear inspection panel is attached with six #8-32 screws. Remove of the rear panel will allow access to the brew solenoid valves and the dilution solenoid valve .195 GPM flow control and check valve.

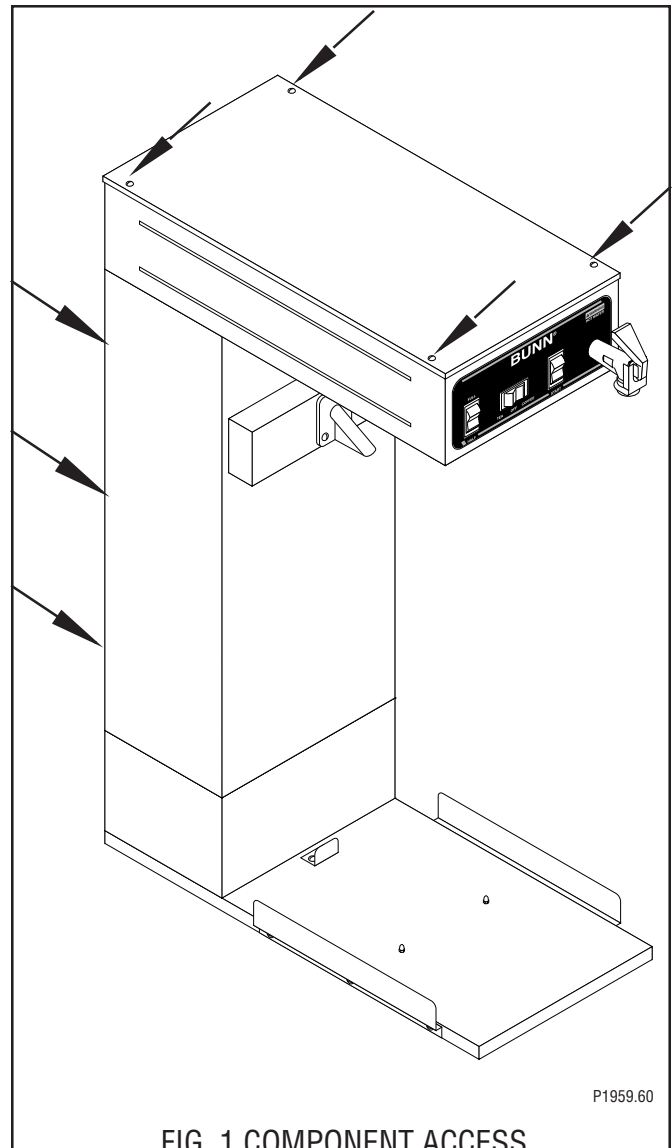

Contents

Brew Solenoid Valve (Hot Coffee)	15
Brew Solenoid Valve (Iced Tea)	16
Brew Timer (Hot Coffee- Early Models)	17
Digital Brew Timer (Hot Coffee-Late Models)	18
Brew Timer (Iced Tea - Early Models)	20
Digital Brew Timer (Iced Tea-Late Models)	21
Control Thermostat	23
Dilution Solenoid Valve	24
Limit Thermostat	25
TEA/OFF/COFFEE Switch	26
Start Switch	27
Tank Heater	28
Thermal Fuse	29
Half Batch Switch (Optional)	30
Wiring Diagrams	31

SERVICE (cont.)
BREW SOLENOID VALVE (HOT COFFEE)

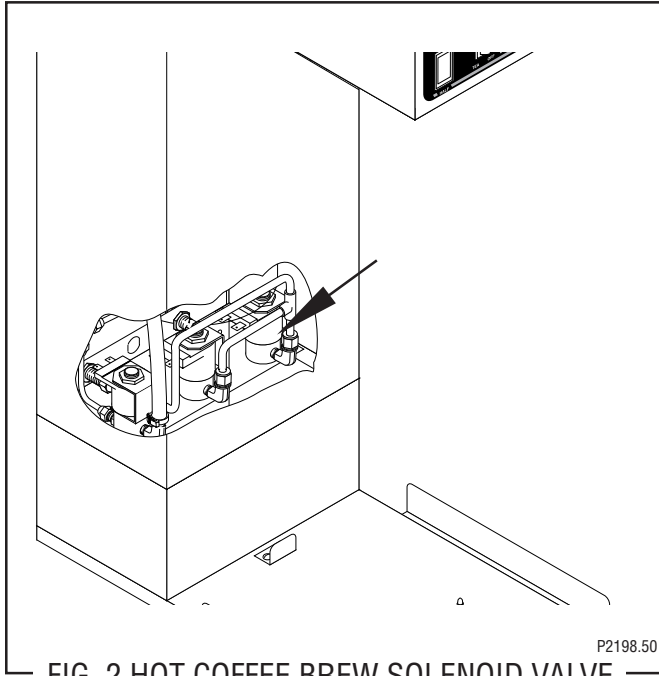

FIG. 2 HOT COFFEE BREW SOLENOID VALVE

Location:

Viewing the brewer from the rear the hot coffee brew solenoid valve is mounted on the left side of the mounting bracket.

Test Procedures:

1. Disconnect the brewer from the power source.
2. Disconnect the white/red and white/green wires from the hot coffee solenoid valve. With the TEA/OFF/COFFEE switch in the "COFFEE" position press the START switch.
3. With a voltmeter, check the voltage across the white/red and white/green wires. Connect the brewer to the power source. The indication must be 120 volts ac for two wire 120 volt models and three wire 120/208 volt models.
4. Disconnect the brewer from the power source.

If voltage is present as described, proceed to #5
 If voltage is not present as described, refer to *Wiring Diagrams* and check brewer wiring harness.

5. Check for continuity across the hot coffee solenoid valve coil terminals.

If continuity is present as described, reconnect the white/red and white/green wires from the hot coffee brew timer.

If continuity is not present as described, replace the solenoid valve.

6. Check the hot coffee solenoid valve for coil action. Connect the brewer to the power source. With TEA/OFF/COFFEE switch in the "COFFEE" position press the START switch and listen carefully in the vicinity of the solenoid valve for a "clicking" sound as the coil magnet attracts.
7. Disconnect the brewer from the power source.

If the sound is heard as described and water will not pass through the solenoid valve, there may be a blockage in the water line before the solenoid valve or, the solenoid valve may require inspection for wear, and removal of waterborne particles.

If the sound is not heard as described, replace the solenoid valve.

Removal and Replacement:

1. Remove all wires from solenoid valves.
2. Turn off the water supply to the brewer.
3. Disconnect the water lines to and from the solenoid valves.
4. Remove the two #8-32 keps nuts holding the mounting bracket to the brewer base.
5. Lift out the bracket.
6. Remove the two #10-32 slotted-head screws holding the hot coffee solenoid valve to the mounting bracket.
7. Securely install the new hot coffee solenoid valve to the mounting bracket.
8. Attach the mounting bracket to the brewer base.
9. Securely fasten the water lines to and from the solenoid valves.
10. Refer to Fig. 3 when reconnecting the wires.

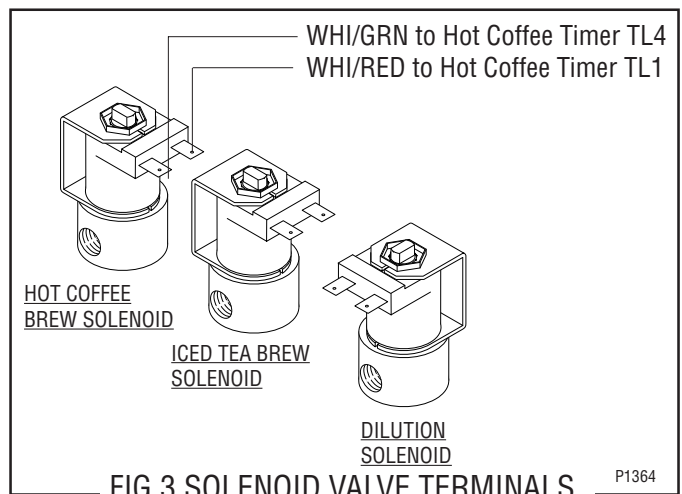

FIG.3 SOLENOID VALVE TERMINALS

SERVICE (cont.)

BREW SOLENOID VALVE (ICED TEA)

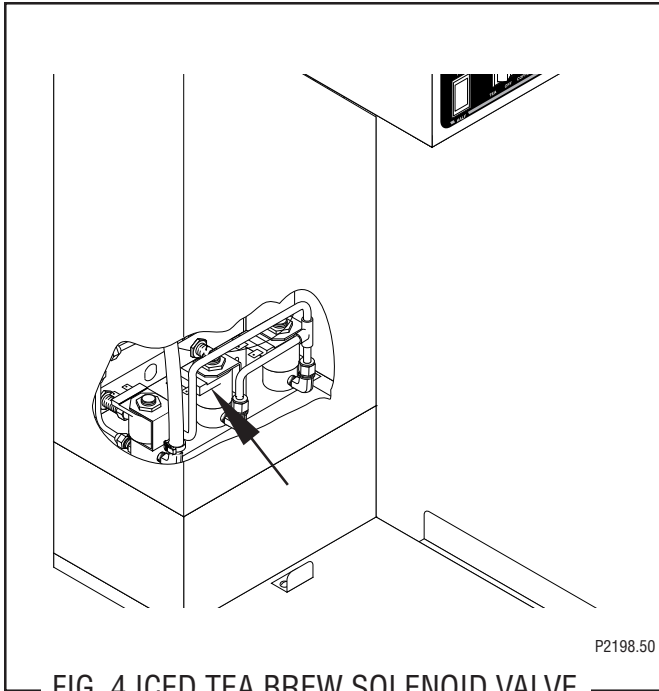

FIG. 4 ICED TEA BREW SOLENOID VALVE

Location:

Viewing the brewer from the rear, the iced tea brew solenoid valve is mounted in the center of the mounting bracket.

Test Procedures:

1. Disconnect the brewer from the power source.
2. Disconnect the white/violet and white/blue wires from the iced tea brew solenoid valve. With the TEA/OFF/COFFEE switch in the "TEA" position press the START switch.
3. With a voltmeter, check the voltage across the white/violet and white/blue wires. Connect the brewer to the power source. The indication must be 120 volts ac for two wire 120 volt models and three wire 120/208 volt models.
4. Disconnect the brewer from the power source.

If voltage is present as described, proceed to #5
If voltage is not present as described, refer to *Wiring Diagrams* and check brewer wiring harness.

5. Check for continuity across the iced tea brew solenoid valve coil terminals.

If continuity is present as described, reconnect the white/violet and white/blue wires from the iced tea brew timer.

If continuity is not present as described, replace the solenoid valve.

6. Check the iced tea solenoid valve for coil action. Connect the brewer to the power source. With TEA/OFF/COFFEE switch in the "TEA" position press the START switch and listen carefully in the vicinity of the solenoid valve for a "clicking" sound as the coil magnet attracts.
7. Disconnect the brewer from the power source.

If the sound is heard as described and water will not pass through the solenoid valve, there may be a blockage in the water line before the solenoid valve or, the solenoid valve may require inspection for wear, and removal of waterborne particles.

If the sound is not heard as described, replace the solenoid valve.

Removal and Replacement:

1. Remove all wires from solenoid valves.
2. Turn off the water supply to the brewer.
3. Disconnect the water lines to and from the solenoid valves.
4. Remove the two #8-32 keps nuts holding the mounting bracket to the brewer base.
5. Lift out the bracket.
6. Remove the two #10-32 slotted-head screws holding the iced tea brew solenoid valve to the mounting bracket.
7. Securely install the new iced tea brew solenoid valve to the mounting bracket.
8. Attach the mounting bracket to the brewer base.
9. Securely fasten the water lines to and from the solenoid valves.
10. Refer to Fig. 5 when reconnecting the wires.

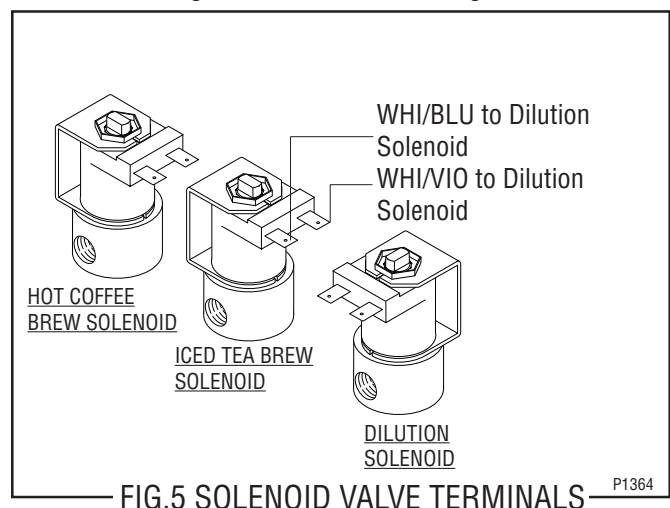
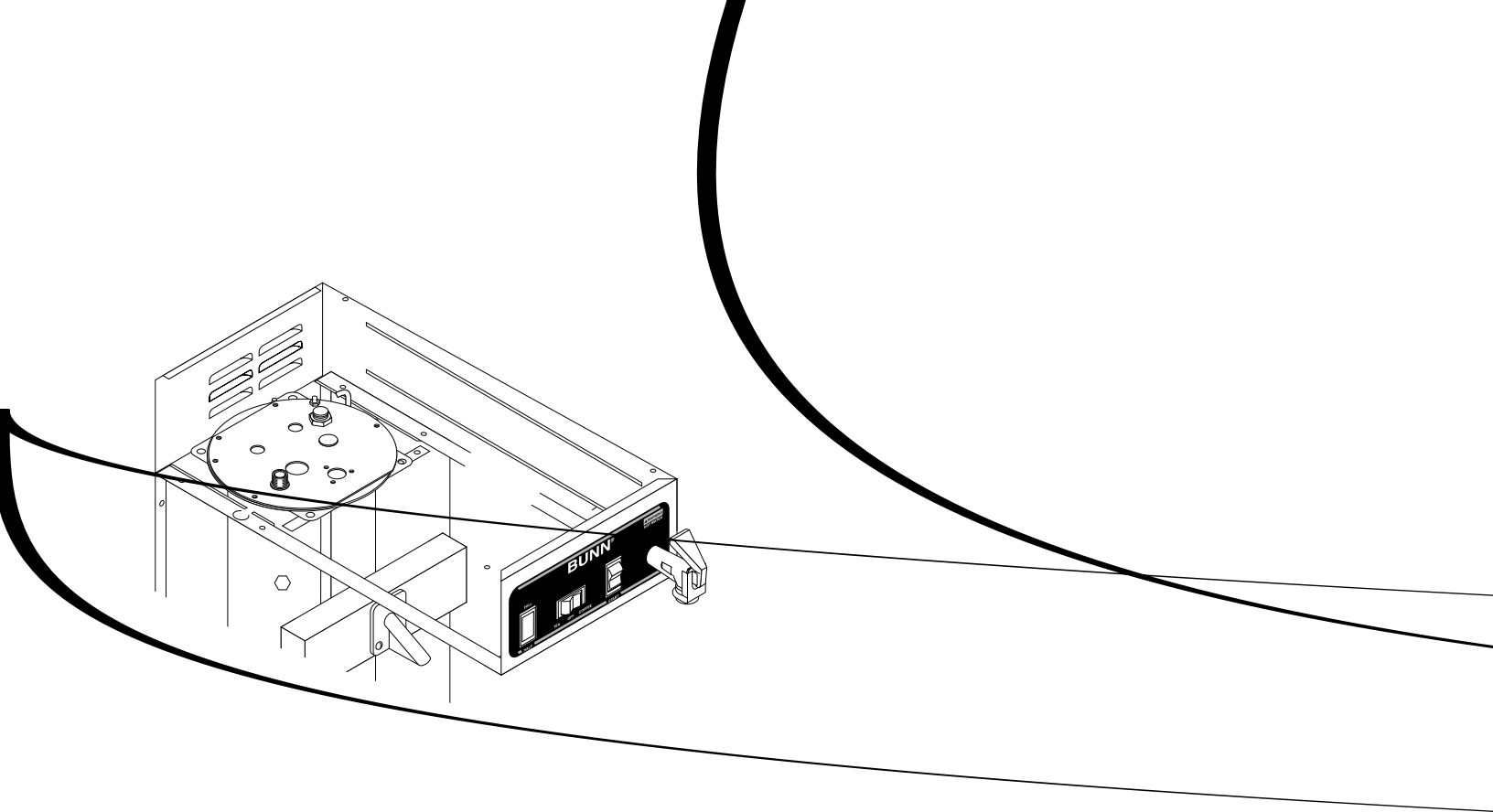
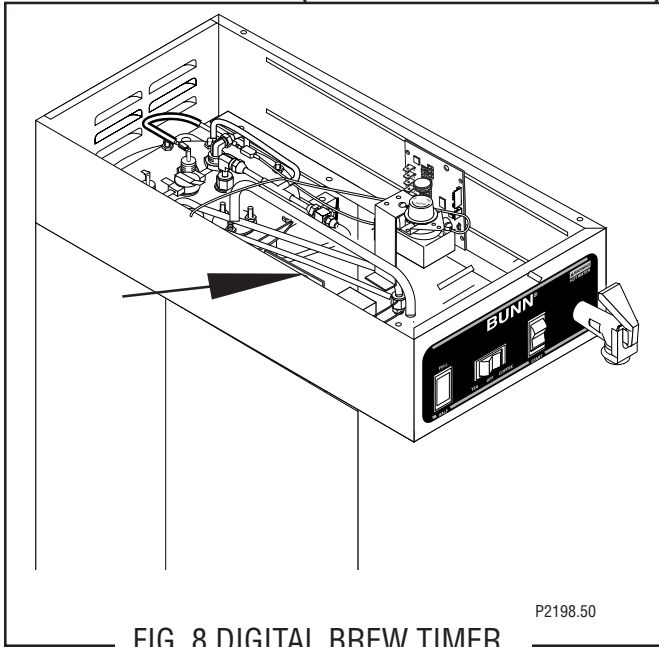

FIG.5 SOLENOID VALVE TERMINALS



SERVICE (cont.)

DIGITAL BREW TIMER (HOT COFFEE -Late Models)



Location:

The timer is located inside the hood on the left side.

Test Procedure.

NOTE: Do not remove or install wires while timer board is installed. Pressure applied to one side may cause damage to the board.

1. Disconnect the brewer from the power source and remove the front access panel.
2. Remove the two #8-32 screws securing circuit board to the mounting bracket.
3. Remove circuit board and spacers (as required).
4. With a voltmeter, check the voltage across terminals TL1 and TL2 when the "TEA/OFF/COFFEE" switch is in the "COFFEE" position. Connect the brewer to the power source. The indication must be 120 volts ac for two wire 120 volt models and three wire 120/208 volt models.
5. Disconnect the brewer from the power source.

If voltage is present as described, proceed to #6. If voltage is not present as described, refer to the *Wiring Diagrams* and check the brewer wiring harness.

6. With a voltmeter, check the voltage across terminals TL1 and TL4 when the "TEA/OFF/COFFEE" switch is in the "COFFEE" position. Connect the brewer to the power source. The indication must be 0 volts.

If voltage is as described, proceed to #7.

If voltage is not as described, disconnect the brewer from the power source and replace the timer.

7. With a voltmeter, check the voltage across terminals TL1 and TL4 when the "TEA/OFF/COFFEE" switch is in the "COFFEE" position. Connect the brewer to the power source and press the START switch. The indication must be 120 volts ac for two wire 120 volt models and three wire 120/208 volt models.

If voltage is present as described, the brew timer is operating properly. Reset the timer as required, to obtain the desired brew volume.

If voltage is not present as described, disconnect the brewer from the power source and replace the timer.

Removal and Replacement:

1. Remove the two #8-32 screws securing circuit board to the mounting bracket.
2. Remove circuit board and spacers (as required).
3. Remove all wires from the timer.
4. Attach all wires to the replacement timer board prior to installation to the component mounting bracket. Refer to FIG. 9 when reconnecting the wires.
5. Install new circuit board with spacers (as required) to the component mounting bracket.
6. Adjust the timer as described below.

Timer Setting:

NOTE: Prior to setting or modifying volumes, check that the brewer is connected to water supply, the tank is properly filled, and a funnel and server are in place.

NOTE: All volume settings must be done with the sprayhead installed.

SERVICE (cont.)

DIGITAL BREW TIMER (HOT COFFEE - Late Models)(cont.)

1. **Modifying brew volumes.** To modify a brew volume, first check that the SET/LOCK switch is in the “SET” position on the circuit board.

To increase a brew volume, place the TEA/OFF/COFFEE switch in the “COFFEE” position, press and hold the START switch until three clicks are heard. Release the switch and press it again one or more times. (Failure to release the switch within two seconds after the third click causes the volume setting to be aborted and previous volume setting will remain in memory.) Each time the switch is pressed, two seconds are added to the brew time period. Allow the brew cycle to finish in order to verify that the desired volume has been achieved.

To decrease a brew volume, place the TEA/OFF/COFFEE switch in the “COFFEE” position, press and release the START switch once for every two-second interval to be removed from the total brew time period; then immediately press and hold down the START switch until three clicks are heard. Release the switch. (Failure to release the switch within two seconds after the third click causes the volume setting to be aborted and previous volume setting will remain in memory). Allow the brew cycle to finish in order to verify that the desired volume has been achieved.

2. **Setting brew volumes.** To set a brew volume, first check that the SET/LOCK switch is in the “SET” position on the circuit board. Place the TEA/OFF/COFFEE switch in the “COFFEE” position, press and hold the START switch until three distinct clicks are heard and then release the switch. (Failure to release the switch within two seconds after the third click causes the volume setting to be aborted and previous volume

ume setting will remain in memory.)

View the level of the liquid being dispensed. When the desired level is reached, turn the TEA/OFF/COFFEE switch to “OFF”.

NOTE: Several ounces of water will continue to syphon from the tank after turning the switch “OFF”. The brewer remembers this volume and will continue to brew batches of this size until the volume setting procedure is repeated.

NOTE: When brewing coffee, volume will decrease due to absorption by the coffee grounds.

3. **Setting programming disable feature.** If it becomes necessary to prevent anyone from changing brew time once programmed, you can set the SET/LOCK switch to the “LOCK” position. This will prevent any further programming until switch is once again put into the “SET” position.

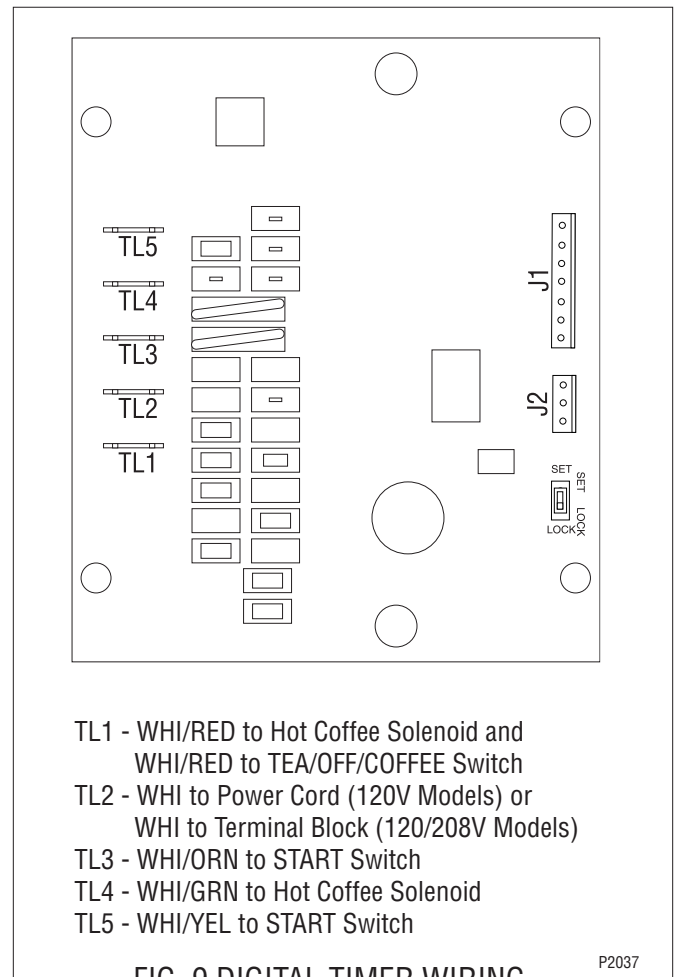

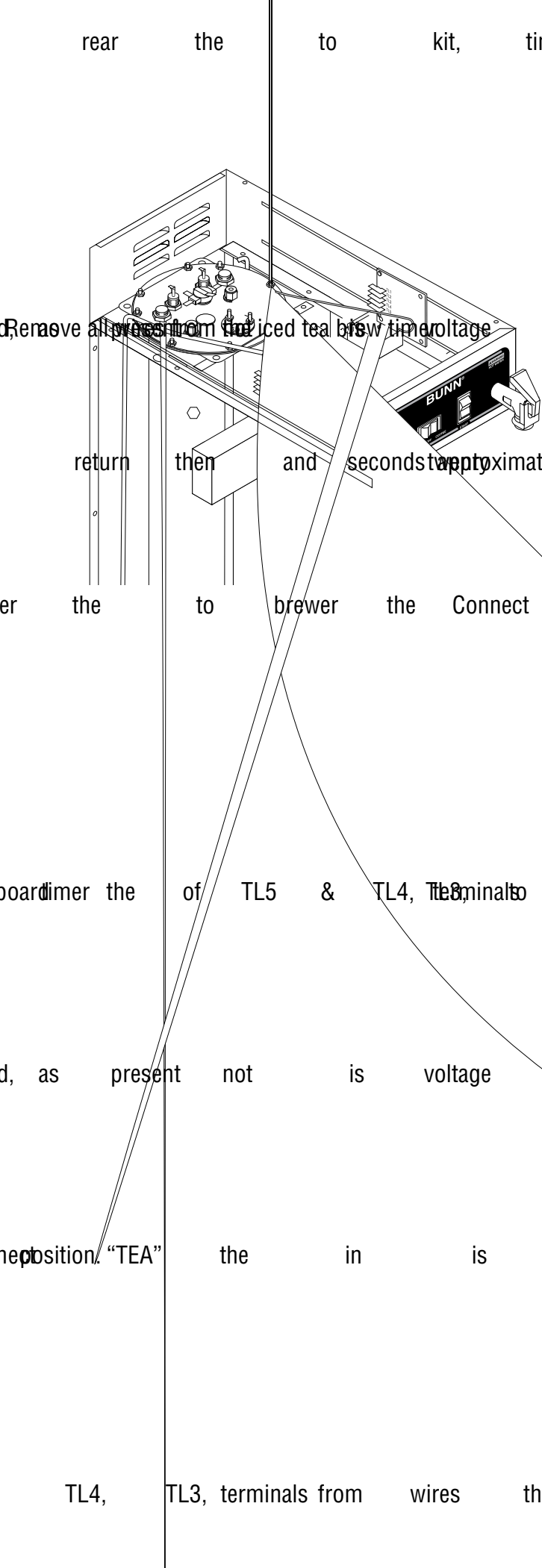

5. Install the Timer Setting decal, provided with the
4. Refer to Fig. 13 when reconnecting the wires.
3. Install the new timer circuit board as described in Late Model Section
- brackets.
2. Remove the circuit board and dial plate from the
- If
6. Disconnect the brewer from the power source.
- ing properly. Adjust the timer dial as required.
- to its previous indication.
- If voltage is present as described, the timer is operat-
- volt models and three wire 120/208 volt models
- indication must be 120 volts ac for two wire 120
- tion.
- switch is momentarily placed in the lower posi-
- switch is in the "TEA" position and the START
- nals TL1 and TL4 when the TEA/OFF/COFFEE
5. With a voltmeter, check the voltage across the
- Wiring Diagrams and
- and proceed to #5.
- wires
- If continuity is present as described, reconnect the
- lower position.
- ing Diagram and check the wiring harness, when
3. Disconnect the brewer from the power source.
4. Check for continuity across the orange and yel-
- wire 120/208 volt models.
- If voltage is present as described, proceed to #4.
- volts ac for two wire 120 volt models and three
- to the power source. The indication must be 120
- switch
- nals TL1 and TL2 when the TEA/OFF/COFFEE
2. With a voltmeter, check the voltage across termi-
- terclockwise.
- of the iced tea timer and rotate the dial fully coun-

SERVICE (cont.)

DIGITAL BREW TIMER (ICED TEA - Late Models)

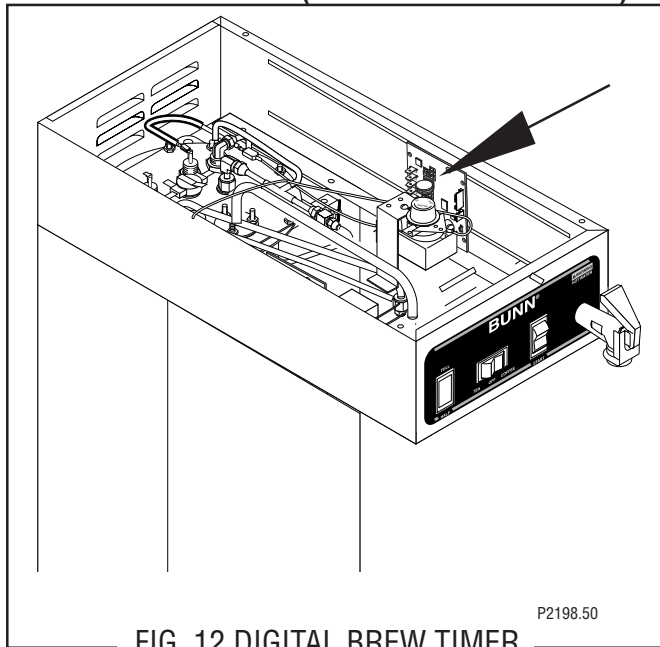

FIG. 12 DIGITAL BREW TIMER

Location:

The timer is located inside the hood, on the right side.

Test Procedure.

NOTE: Do not remove or install wires while timer board is installed. Pressure applied to one side may cause damage to the board.

1. Disconnect the brewer from the power source and remove the front access panel.
2. Remove the two #8-32 screws securing circuit board to the hood.
3. Remove circuit board and spacers (as required).
4. With a voltmeter, check the voltage across terminals TL1 and TL2 when the "TEA/OFF/COFFEE" switch is in the "TEA" position. Connect the brewer to the power source. The indication must be 120 volts ac for two wire 120 volt models and three wire 120/208 volt models.
5. Disconnect the brewer from the power source.

If voltage is present as described, proceed to #6.

If voltage is not present as described, refer to the *Wiring Diagrams* and check the brewer wiring harness.

6. With a voltmeter, check the voltage across terminals TL1 and TL4 when the "TEA/OFF/COFFEE" switch is in the "TEA" position. Connect the brewer to the power source. The indication must be 0 volts.

If voltage is as described, proceed to #7.

If voltage is not as described, disconnect the brewer from the power source and replace the timer.

7. With a voltmeter, check the voltage across terminals TL1 and TL4 when the "TEA/OFF/COFFEE" switch is in the "TEA" position. Connect the brewer to the power source and press the START switch. The indication must be 120 volts ac for two wire 120 volt models and three wire 120/208 volt models.

If voltage is present as described, the brew timer is operating properly. Reset the timer as required, to obtain the desired brew volume.

If voltage is not present as described, disconnect the brewer from the power source and replace the timer.

Removal and Replacement:

1. Remove the two #8-32 screws securing circuit board to the mounting bracket.
2. Remove circuit board and spacers (as required).
3. Remove all wires from the timer.
4. Attach all wires to the replacement timer board prior to installation to the component mounting bracket. Refer to FIG. 13 when reconnecting the wires.
5. Install new circuit board with spacers (as required) to the component mounting bracket.
6. Adjust the timer as described below.

Timer Setting:

NOTE: Prior to setting or modifying volumes, check that the brewer is connected to water supply, the tank is properly filled, and a funnel and server are in place.

NOTE: All volume settings must be done with the sprayhead installed.

SERVICE (cont.)

DIGITAL BREW TIMER (ICED TEA - Late Models)(cont.)

1. **Modifying brew volumes.** To modify a brew volume, first check that the SET/LOCK switch is in the “SET” position on the circuit board.

To increase a brew volume, place the TEA/OFF/COFFEE switch in the “TEA” position, press and hold the START switch until three clicks are heard. Release the switch and press it again one or more times. (Failure to release the switch within two seconds after the third click causes the volume setting to be aborted and previous volume setting will remain in memory.) Each time the switch is pressed, two seconds are added to the brew time period. Allow the brew cycle to finish in order to verify that the desired volume has been achieved.

To decrease a brew volume, place the TEA/OFF/

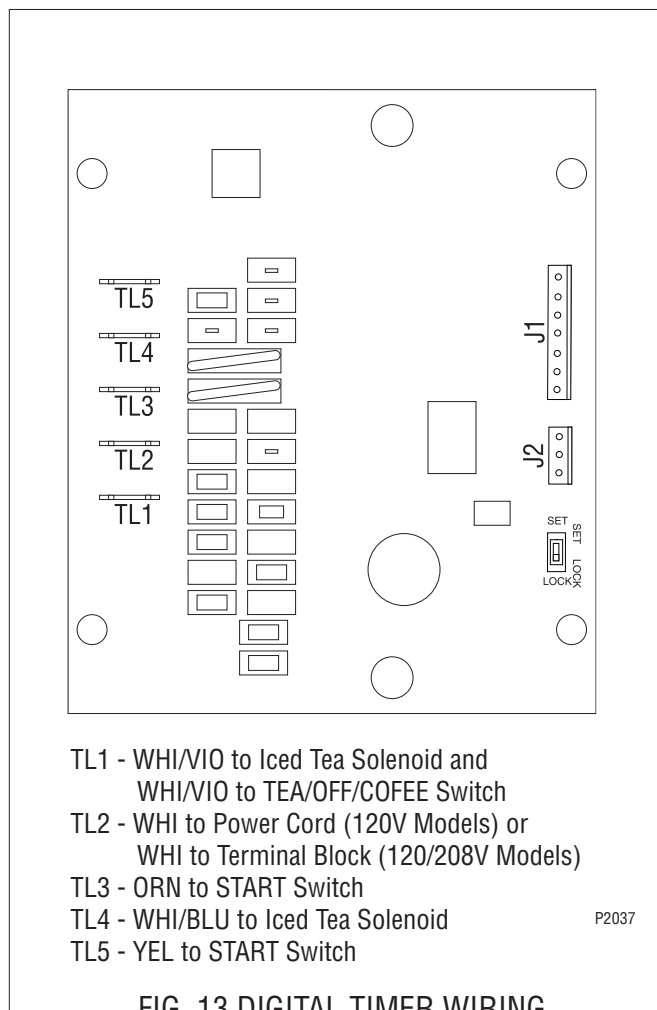

SERVICE (cont.)

CONTROL THERMOSTAT

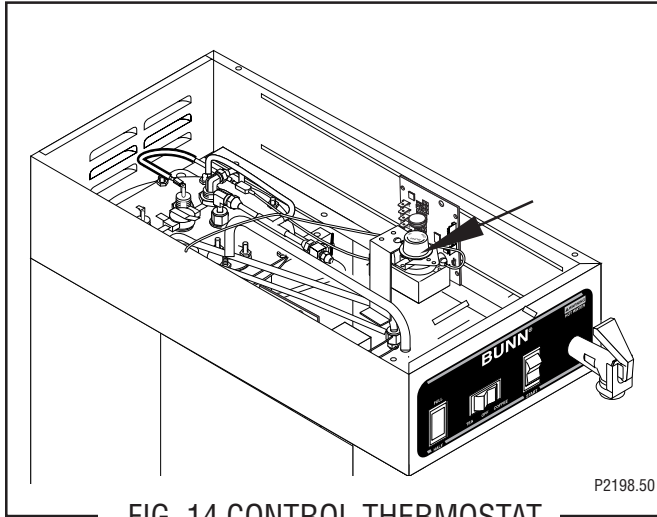

FIG. 14 CONTROL THERMOSTAT

Location:

The control thermostat is located inside hood on the right side to the left of the iced tea brew timer.

Test Procedures:

1. Disconnect the brewer from the power source.
2. With a voltmeter, check the voltage across the blue wire on the control thermostat and the white wire on the tank heater for 120 volt two wire models or red wire on the tank heater for 120/208 volt three wire models. Connect the brewer to the power source. The indication must be 120 volts ac for two wire 120 volt models and 208 volts ac for three wire 120/208 volt models.
3. Disconnect the brewer from the power source.

If voltage is present as described, proceed to #4.

If voltage is not present as described, refer to the *Wiring Diagrams* and check the brewer wiring harness.

4. Locate the black wire on the control thermostat.
5. Gently remove the capillary bulb and grommet from the tank.
6. With a voltmeter, check the voltage across the black wire of the control thermostat and the white wire on the tank heater for 120 volt two wire models or red wire on the tank heater for 120/208 volt three wire models when the control thermostat is turned fully clockwise. Connect the brewer to the power source. The indication must be 120 volts ac for two wire 120 volt models and 208 volts ac for three wire 120/208 volt models.

8. Disconnect the brewer from the power source.

If voltage is present as described, reinstall the capillary tube into the tank to the line 4.5" above the bulb, the control thermostat is operating properly.

If voltage is not present as described, replace the thermostat.

Removal and Replacement:

1. Remove both wires from the control thermostat terminals.
2. Remove the thermostat capillary bulb by firmly pulling up on the capillary tube at the tank lid. This will disengage the grommet from the tank lid.
3. Remove the #8-32 screw holding the control thermostat to its bracket.
4. Slide the grommet to the line 4.5" above the bulb on the new capillary tube.
5. Insert the capillary bulb through the hole in the tank lid and press the grommet firmly and evenly so that the groove in the grommet fits into the tank lid.
6. Carefully bend the capillary tube so that the tube and bulb inside the tank are in a vertical position.

NOTE – The capillary tube must be clear of any electrical termination and not kinked.

7. Fasten the new control thermostat to its bracket.
8. Refer to Fig. 15 when reconnecting the wires.
9. Adjust the control thermostat as required.

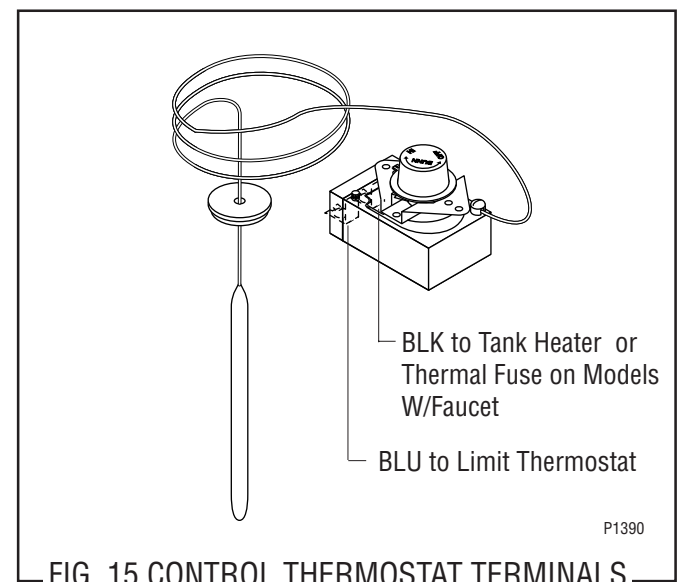

FIG. 15 CONTROL THERMOSTAT TERMINALS

SERVICE (cont.)

DILUTION SOLENOID VALVE

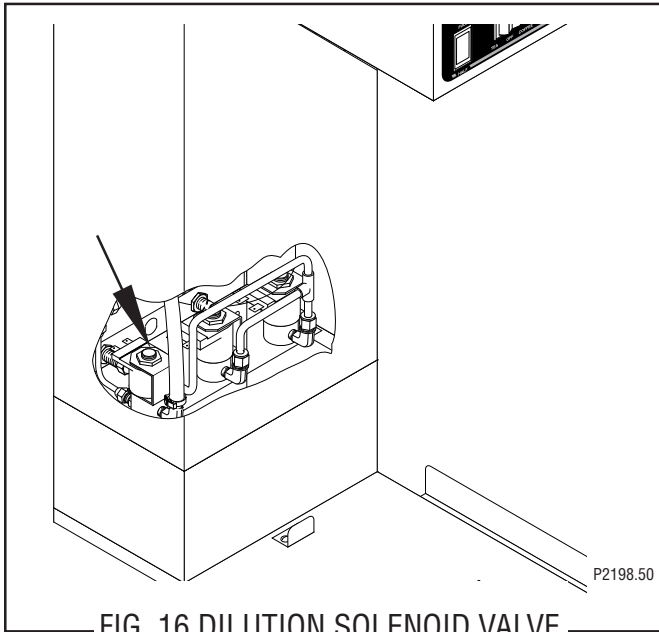

FIG. 16 DILUTION SOLENOID VALVE

Location:

Viewing the brewer from the rear the dilution solenoid is mounted on the right side of the solenoid mounting bracket which is secured to the trunk base.

Test Procedure:

1. Disconnect the brewer from the power source.
2. With a voltmeter, check the voltage across the white/blue and white/violet wires on the dilution solenoid terminals when the TEA/OFF/COFFEE switch is in the "TEA" position and the START switch is momentarily placed in the lower position. Connect the brewer to the power source. The indication must be 120 volts ac for two wire 120 volt models and three wire 120/208 volt models.
3. Disconnect the brewer from the power supply.

If voltage is present as described, proceed to #4.

If voltage is not present as described, refer to the *Wiring Diagrams* and check the wiring harness.

4. Remove both wires from the coil and check for continuity across the coil terminals.

If continuity is present as described, reconnect the white/blue and white/violet wires and proceed to #5. If continuity is not present as described, replace the solenoid valve.

5. Check the solenoid valve for coil action. Connect the brewer to the power source, place the TEA/OFF/COFFEE switch in the "TEA" position and momentarily place the START switch in the lower position and release. Listen carefully in the vicinity of the solenoid valve for a "clicking" sound as the coil magnet attracts.
6. Disconnect the brewer from the power source.

If the sound is heard as described and water will not pass through the solenoid valve, there may be a blockage in the water line before or after the solenoid valve or, the solenoid valve may require inspection for wear, and removal of waterborne particles.

If the sound is not heard as described, replace the solenoid valve.

Removal and Replacement:

1. Remove all wires from the solenoid valves.
2. Turn off the water supply to the brewer.
3. Disconnect the water lines to and from the solenoid valves.
4. Remove the two #8-32 keps nuts holding the mounting bracket to the trunk base.
5. Lift out the bracket.
6. Remove the two #10-32 slotted-head screws holding the solenoid valve to the mounting bracket.
7. Securely install the new solenoid valve to the mounting bracket.
8. Attach the mounting bracket to the trunk base.
9. Securely fasten the water lines to and from the solenoid valves.
10. Refer to Fig. 17 when reconnecting the wires.



FIG. 17 SOLENOID VALVE TERMINALS

SERVICE (cont.)

LIMIT THERMOSTAT

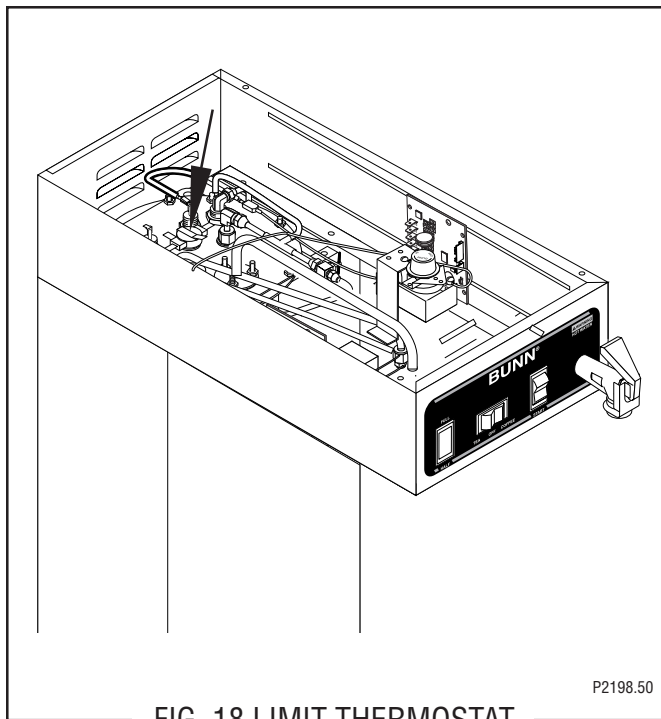

FIG. 18 LIMIT THERMOSTAT

Location:

The limit thermostat is located inside the hood on the tank lid.

Test Procedure:

1. Disconnect the brewer from the power source and remove the black wire from the limit thermostat.
2. With a voltmeter, check the voltage across the black wire removed from the limit thermostat and the white or red wire on the tank heater terminal. Connect the brewer to the power source. The indication must be:
 - a) 120 volts ac for two wire 120 volt models.
 - b) 208 volts ac for three wire 120/208 volt models.
3. Disconnect the brewer from the power source.

If voltage is present as described, reconnect the black wire and proceed to #4.

If voltage is not present as described, refer to the *Wiring Diagrams* and check the wiring harness.

4. Remove the blue wire from the limit thermostat.

5. With a voltmeter, check the voltage across the exposed terminal of the limit thermostat and the white wire from the power cord or the red wire from the terminal block. Connect the brewer to the power source. The indication must be:
 - a) 120 volts ac for two wire 120 volt models.
 - b) 208 volts ac for three wire 120/208 volt models.
6. Disconnect the brewer from the power source.

If voltage is present as described, reconnect the blue wire to the limit thermostat. The limit thermostat is operating properly.

If voltage is not present as described, replace the limit thermostat.

Removal and Replacement

1. Remove both wires from the limit thermostat terminals.
2. Carefully slide the limit thermostat out from under the retaining clip.
3. Carefully slide the new limit thermostat into the retaining clip.
4. Refer to Fig. 19 when reconnecting the wires.

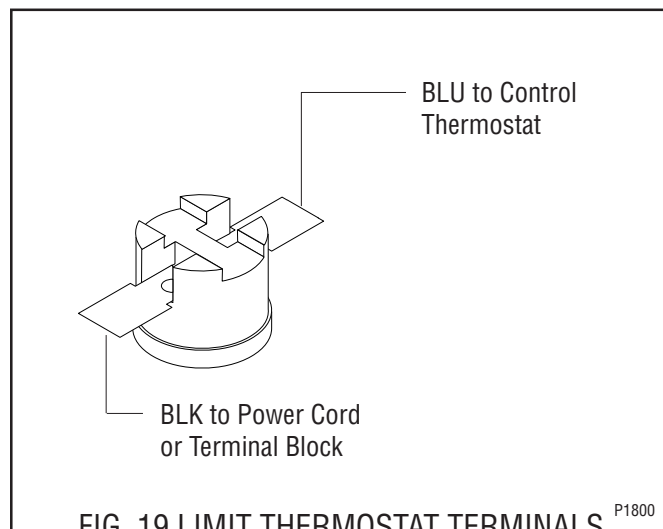

FIG. 19 LIMIT THERMOSTAT TERMINALS

SERVICE (cont.)

TEA/OFF/COFFEE SWITCH

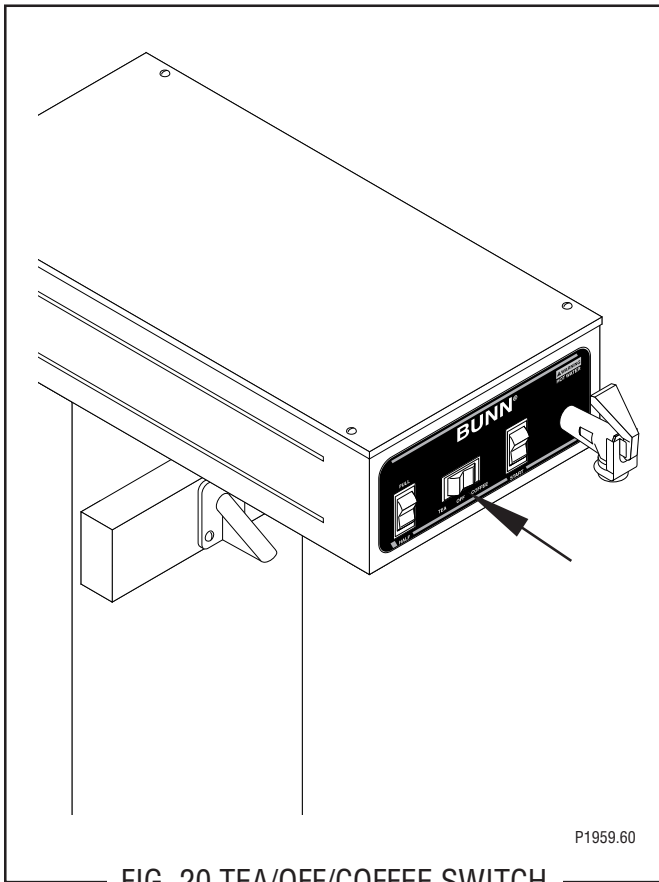

FIG. 20 TEA/OFF/COFFEE SWITCH

Location:

The TEA/OFF/COFFEE switch is located in the front of the hood, above and to the left of the brew funnel.

Test Procedure:

1. Disconnect the brewer from the power source.
2. Remove the black, white/violet and white/red wires from the switch terminals.
3. With a voltmeter, check the voltage across the black wire removed from the TEA/OFF/COFFEE switch and the white wire remaining on the switch terminal.
4. Connect the brewer to the power source. The indication must be 120 volts ac for two wire 120 volt models and three wire 120/208 volt models,
5. Disconnect the brewer from the power source.

If voltage is present as described, proceed to #6. If voltage is not present as described, refer to the *Wiring Diagrams* and check the wiring harness.

6. Check for continuity across the center and left terminals of the top row when switch is in the "TEA" position and the center and right terminals of the top row when the switch is in the "COFFEE" position.

If continuity is present as described, replace the wires, the switch is operating properly.

If continuity is not present as described, replace the switch.

Removal and Replacement:

1. Remove the wires from the switch terminals.
2. Compress the clips inside the hood and gently push the switch through the opening.
3. Push the new switch into the opening and spread the clips to hold the switch captive in the hood.
4. Refer to FIG. 21 when reconnecting the wires.

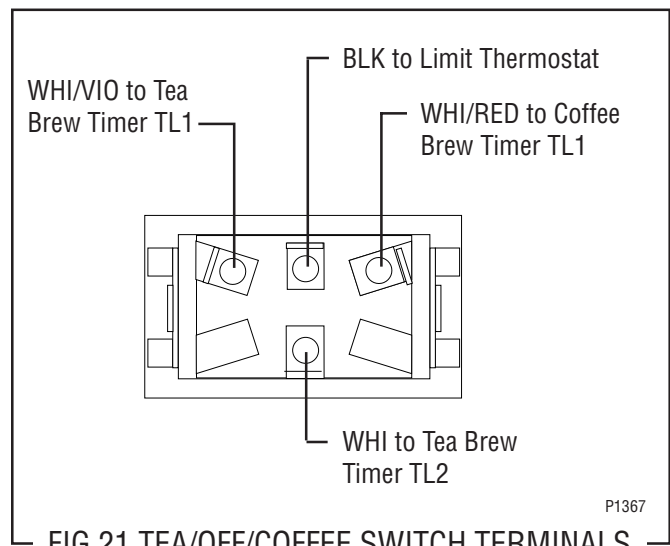

FIG. 21 TEA/OFF/COFFEE SWITCH TERMINALS

SERVICE (cont.)

START SWITCH

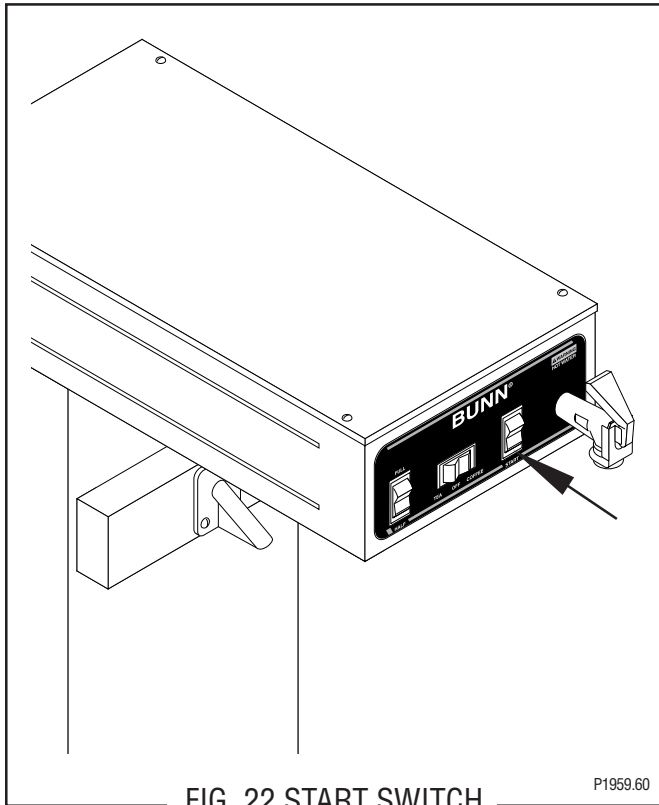

FIG. 22 START SWITCH

Location:

The start switch is located in the front of the hood, above and to the right of the brew funnel.

Test Procedure:

1. Disconnect the brewer from the power source.
2. Remove the wires from all four terminals.
3. Check for continuity across the two terminals on the right side of the switch when it is held in the lower position. Continuity must not be present across these terminals in the upper position.

If continuity is present as described, proceed to #4. If continuity is not present as described, replace the switch.

4. Check for continuity across the two terminals on the left side of the switch when it is held in the lower position. Continuity must not be present across these terminals in the upper position.

If continuity is present as described, reconnect the wires, the switch is operating properly.

If continuity is not present as described, replace the switch.

Removal and Replacement:

1. Remove the wires from the switch terminals.
2. Compress the clips inside the hood and gently push the switch through the opening.
3. Push the new switch into the opening and spread the clips to hold the switch captive in the hood.
4. Refer to Fig. 23 when reconnecting the wires.

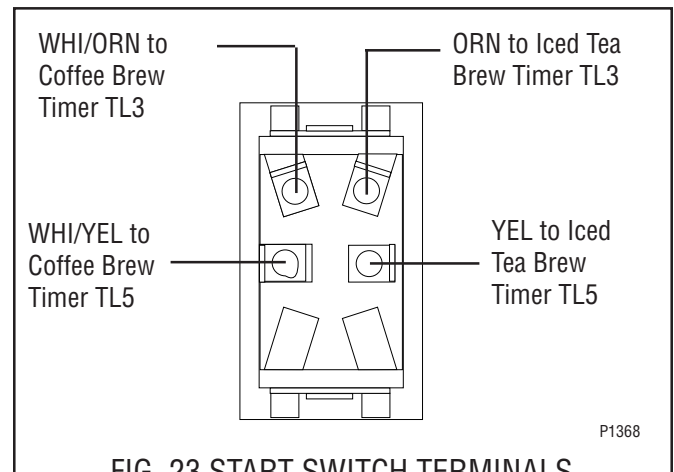
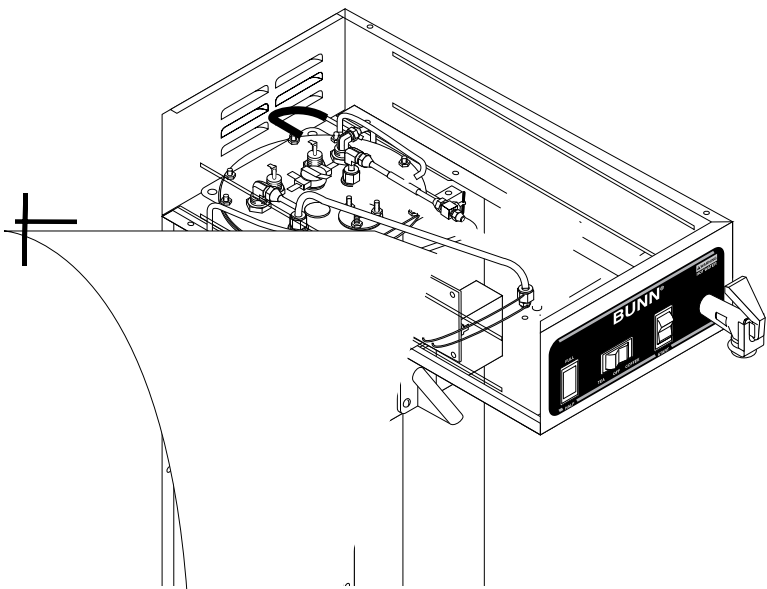

FIG. 23 START SWITCH TERMINALS



SERVICE (cont.)

HALF BATCH SWITCH (Optional)

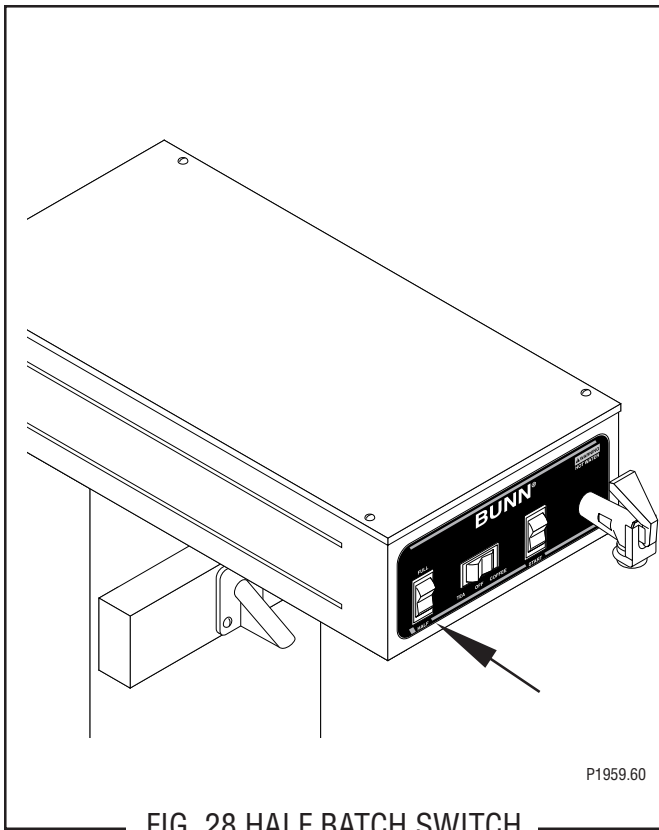

FIG. 28 HALF BATCH SWITCH

Removal and Replacement:

1. Remove the wires from the switch terminals.
2. Compress the clips inside the hood and gently push the switch through the opening.
3. Push the new switch into the opening and spread the clips to hold the switch captive in the hood.
4. Refer to FIG. 29 when reconnecting the wires.

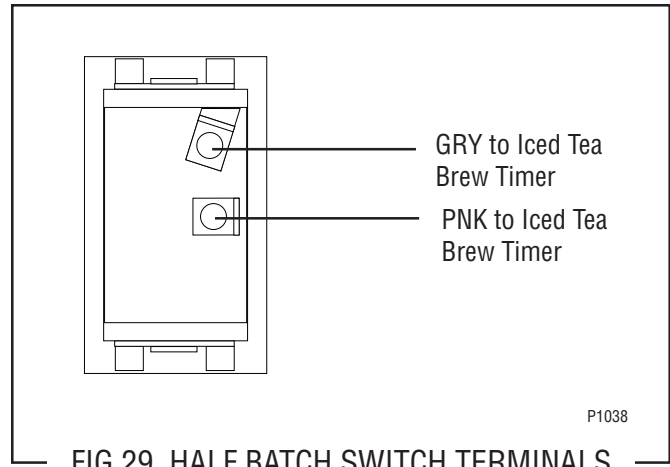

FIG.29 HALF BATCH SWITCH TERMINALS

Location:

The HALF BATCH switch is located in the front of the hood, above and to the far left of the brew funnel.

Test Procedure:

1. Disconnect the brewer from the power source.
2. With an ohmmeter, check for continuity between the two terminals of the switch.

If continuity is present as described, the switch is operating properly.

If continuity is not present as described, replace the switch.

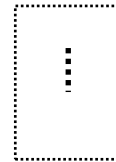

SCHEMATIC WIRING DIAGRAM TW & TWF

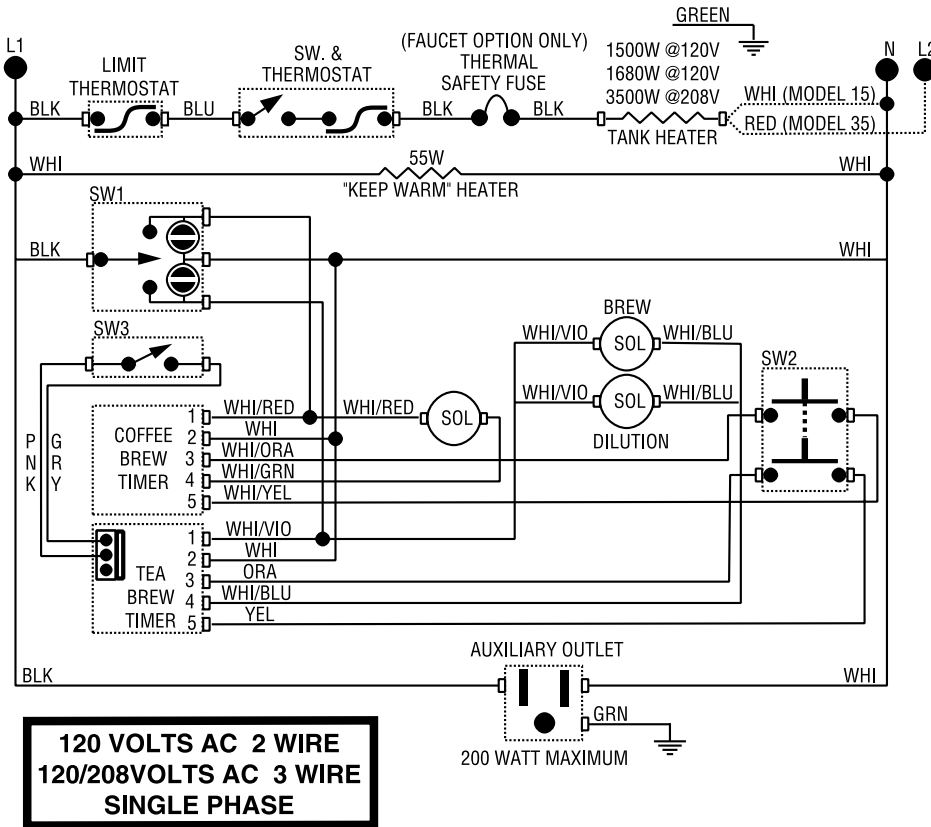

SCHEMATIC WIRING DIAGRAM TWDB

