

SFW10XP

Sencomatic

FINE WIRE STAPLER



Parts Reference Guide



*Repair Kits
YK0321
YK0398*



* Schematic Drawings inside

Senco Products, Inc.
8485 Broadwell Road
Cincinnati, Ohio 45244

Visit our Website www.senco.com

Questions? Comments? call SENCO's toll-free Action-line:
1-800-543-4596 (North & South America only)
or e-mail: toolprof@senco.com

SFW10XP Sencomatic Fine Wire Stapler

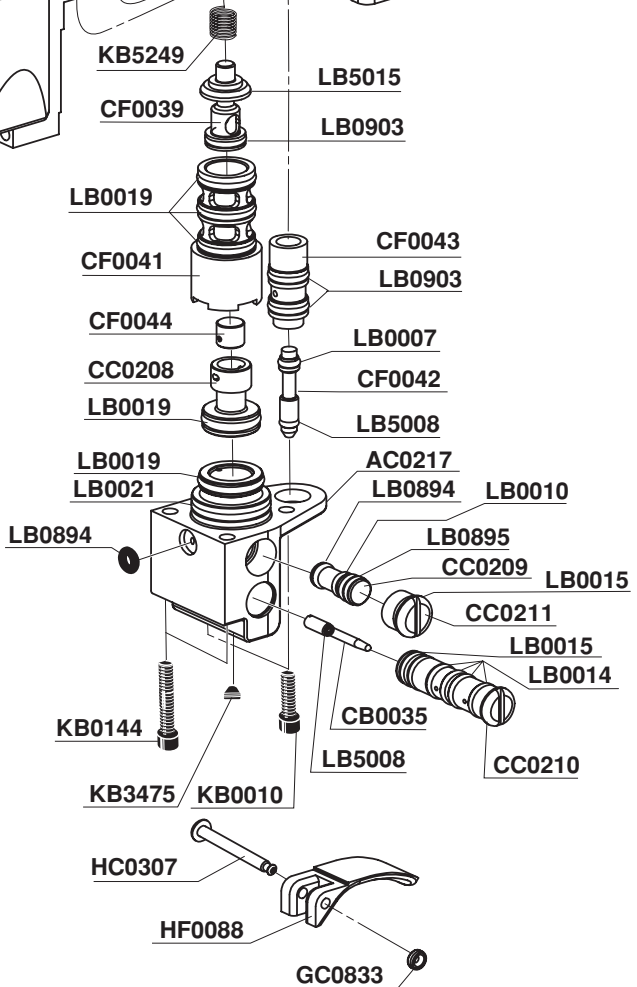
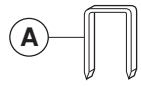
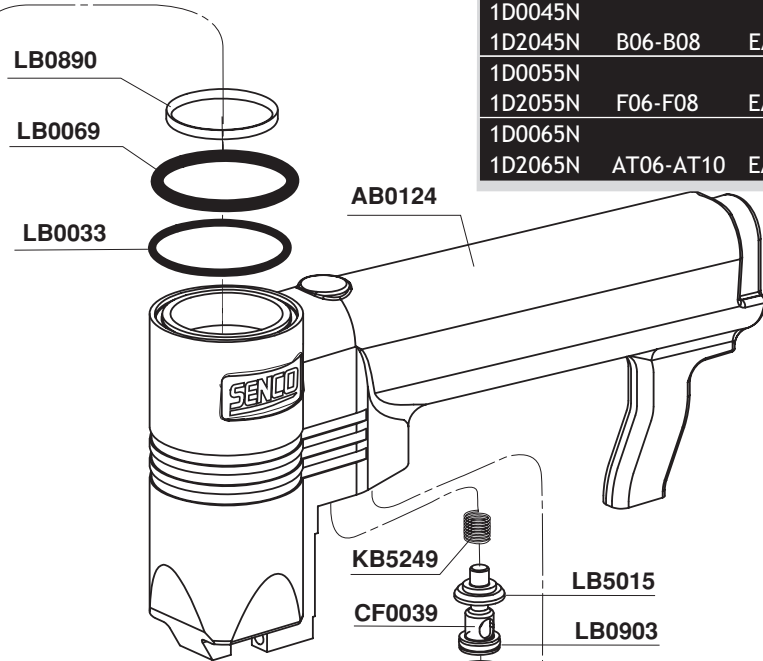
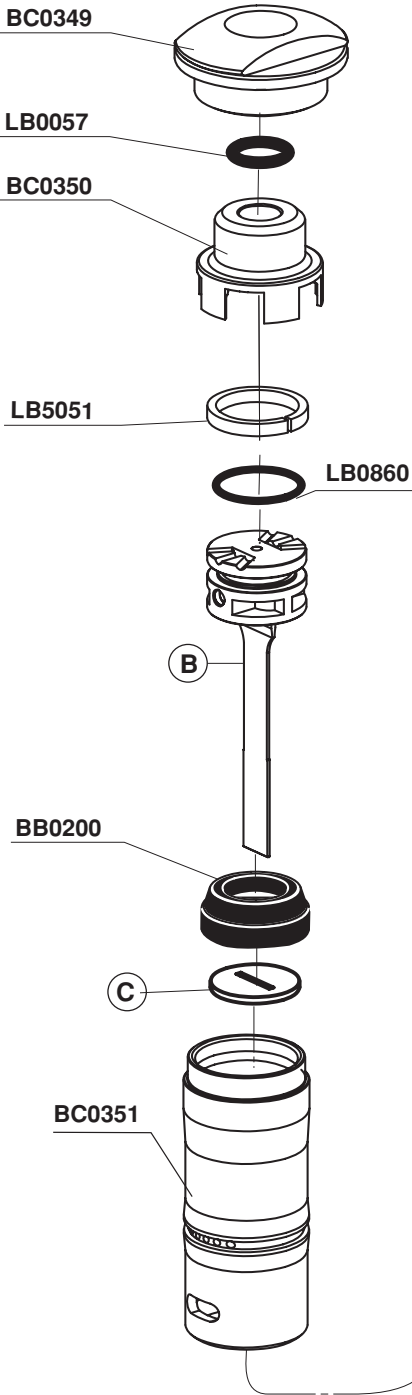

S/M Model	A	B	C
1D0005N			
1D2005N	A06-D10	EA0144	BF0222
1D0015N			
1D2015N	E06-E10	EA0058	BF0222
1D0025N			
1D2025N	C06-C10	EA0036	BF0218
1D0035N			
1D2035N	G06-G10	EA0038	BF0221
1D0045N			
1D2045N	B06-B08	EA0039	BF0220
1D0055N			
1D2055N	F06-F08	EA0037	BF0221
1D0065N			
1D2065N	AT06-AT10	EA0130	BF0220

- * Does Not Include O-rings
- * No incluye sellos de gomas
- * Ohne Dichtringe
- * Joints exclus

SFW10XP Sencomatic



****Use Loctite #243 & Coat threads.**

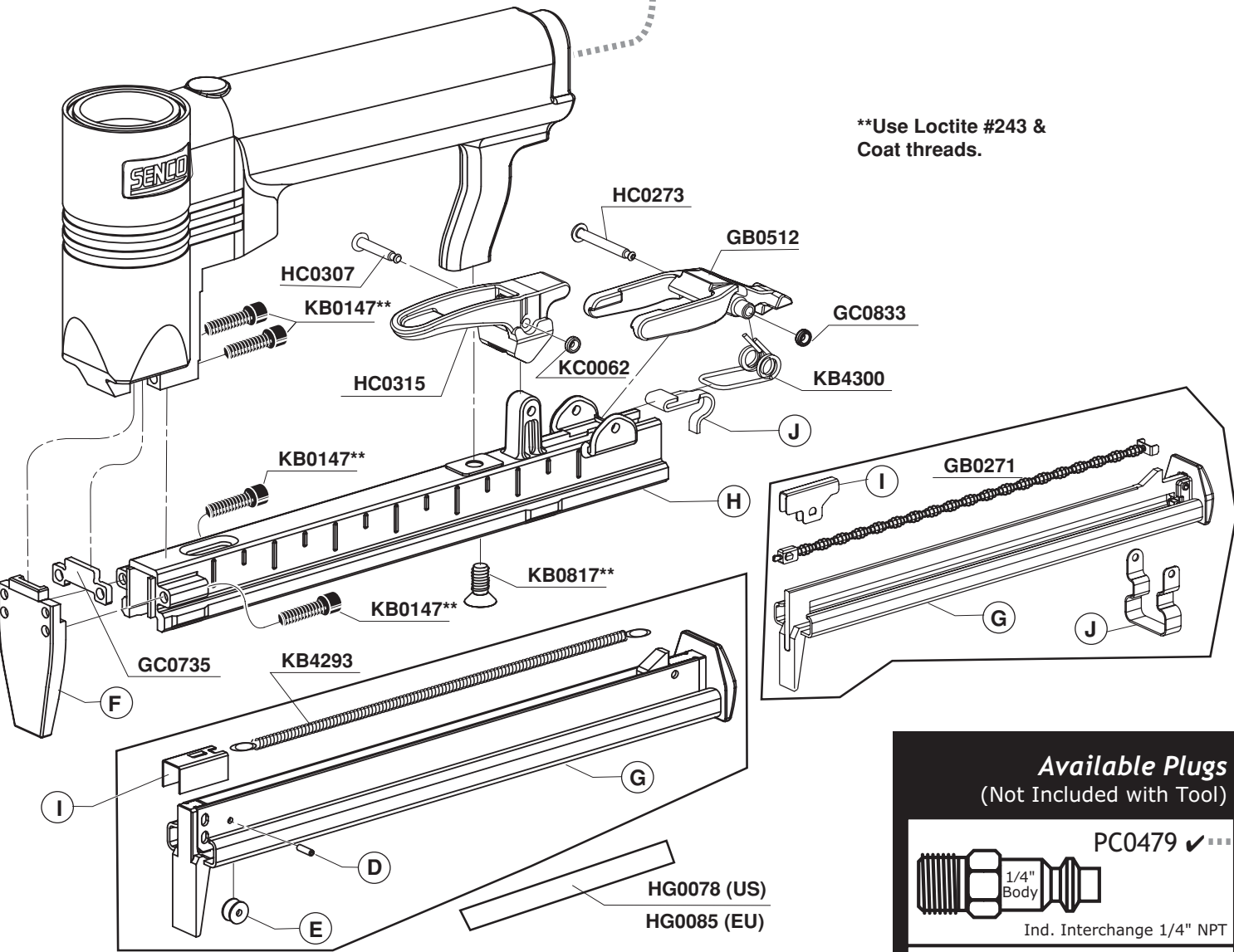

NFG11D Revised April 21, 2003 (Replaces 4/10/03) © 2001, 2003 by SENCO Products, Inc. Cincinnati, Ohio 45244-U.S.A.

Available Plugs (Not Included with Tool)

PC0479 ✓

1/4" Body
Ind. Interchange 1/4" NPT

PC0486

3/8" Body
Ind. Interchange 1/4" NPT

PC0468 ✓

1/4" Body
Tru-Flate 1/4" NPT

PC0474

3/8" Body
Tru-Flate 1/4" NPT

✓ **Recommended Plugs**
Plugs shown smaller than actual size

S/M Model	A	D	E	F	G	H	I	J
1D0005N	A06-D10	N/A	N/A	FC0425	GB0526	GB0532	GC0770	GC0769
1D2005N	A06-D10	N/A	N/A	FC0425	GB0536	GB0532	GC0770	GC0769
1D0015N	E06-E10	N/A	N/A	FC0426	GB0526	GB0533	GC0770	GC0769
1D2015N	E06-E10	N/A	N/A	FC0426	GB0536	GB0533	GC0770	GC0769
1D0025N	C06-C10	KB5145	GC0759	FC0418	GB0473	GB0527	GC0758	GC0763
1D2025N	C06-C10	KB5145	GC0759	FC0418	GB0475	GB0527	GC0758	GC0763
1D0035N	G06-G10	KB5145	GC0759	FC0419	GB0473	GB0528	GC0758	GC0763
1D2035N	G06-G10	KB5145	GC0759	FC0419	GB0475	GB0528	GC0758	GC0763
1D0045N	B06-B08	KB5144	GC0756	FC0420	GB0474	GB0529	GC0755	GC0763
1D2045N	B06-B08	KB5144	GC0756	FC0420	GB0476	GB0529	GC0755	GC0763
1D0055N	F06-F08	KB5144	GC0756	FC0421	GB0474	GB0530	GC0755	GC0763
1D2055N	F06-F08	KB5144	GC0756	FC0421	GB0476	GB0530	GC0755	GC0763
1D0065N	AT06-AT10	KB5144	GC0756	FC0422	GB0474	GB0531	GC0755	GC0763
1D2061N	AT06-AT10	KB5144	GC0756	FC0422	GB0476	GB0531	GC0755	GC0763

SFW10XP Sencomatic Fine Wire Stapler

REPLACEMENT PARTS LIST • LISTA DE PARTES DE REPUESTO • ERSATSTEILE-LISTE • LISTE DE PIÈCES DE RECHANGE

PART NO.	DESCRIPTION	DESCRIPCIÓN	BESCHREIBUNG	DÉSIGNATION
AB0124	BODY	CARCASA	GEHÄUSE	CORPS
AC0217	PLATE	PLACA	PLATTE	PLAQUE
BB0200	STOP	TOPE	PUFFER	ARRÊT
BC0349	CAP	TAPA	KAPPE	BOUCHON
BC0350	VALVE ASSEMBLY	ASAMBLE DE VALVULA	VENTIL-ZUSAMMENBAU	VALVE D'ASSEMBLÉE
BC0351	CYLINDER	CILINDRO	ZYLINDER	CYLINDRE
BF0218	SEAL (C)	SELLO	DICHTUNG	JOINT
BF0220	SEAL (B & AT)	SELLO	DICHTUNG	JOINT
BF0221	SEAL (F & G)	SELLO	DICHTUNG	JOINT
BF0222	SEAL (A & E)	SELLO	DICHTUNG	JOINT
CB0035	CORE	VÁSTAGO	VENTILSTIFT	NOYAU
CC0208	PISTON, LOWER	PISTON	KOLBEN	PISTON
CC0209	PISTON	PISTON	KOLBEN	PISTON
CC0210	VALVE	VALVULA	VENTIL	VALVE
CC0211	CAP	TAPA	KAPPE	BOUCHON
CF0039	PISTON, UPPER	PISTON	KOLBEN	PISTON
CF0041	HOUSING	ALOJAMIENTO	GEHÄUSE	CORPS
CF0042	REMOTE CORE	VÁSTAGO	VENTILSTIFT	NOYAU
CF0043	HOUSING, REMOTE	ALOJAMIENTO	GEHÄUSE	CORPS
CF0044	SEAL	SELLO	DICHTUNG	JOINT
EA0036	PISTON ASSY (C)	ASAMBLE DE PISTON	KOLBEN-ZUSAMMENBAU	PISTON D'ASSEMBLÉE
EA0037	PISTON ASSY (F)	ASAMBLE DE PISTON	KOLBEN-ZUSAMMENBAU	PISTON D'ASSEMBLÉE
EA0038	PISTON ASSY (G)	ASAMBLE DE PISTON	KOLBEN-ZUSAMMENBAU	PISTON D'ASSEMBLÉE
EA0039	PISTON ASSY (B)	ASAMBLE DE PISTON	KOLBEN-ZUSAMMENBAU	PISTON D'ASSEMBLÉE
EA0058	PISTON ASSY (E)	ASAMBLE DE PISTON	KOLBEN-ZUSAMMENBAU	PISTON D'ASSEMBLÉE
EA0130	PISTON ASSY (AT)	ASAMBLE DE PISTON	KOLBEN-ZUSAMMENBAU	PISTON D'ASSEMBLÉE
EA0144	PISTON ASSY (A)	ASAMBLE DE PISTON	KOLBEN-ZUSAMMENBAU	PISTON D'ASSEMBLÉE
FC0418	GUIDE BODY (C)	PLACA DE NARIZ	KLAMMERFÜHRUNG	FRONT
FC0419	GUIDE BODY (G)	PLACA DE NARIZ	KLAMMERFÜHRUNG	FRONT
FC0420	GUIDE BODY (B)	PLACA DE NARIZ	KLAMMERFÜHRUNG	FRONT
FC0421	GUIDE BODY (F)	PLACA DE NARIZ	KLAMMERFÜHRUNG	FRONT
FC0422	GUIDE BODY (AT)	PLACA DE NARIZ	KLAMMERFÜHRUNG	FRONT
FC0425	GUIDE BODY (A)	PLACA DE NARIZ	KLAMMERFÜHRUNG	FRONT
FC0426	GUIDE BODY (E)	PLACA DE NARIZ	KLAMMERFÜHRUNG	FRONT
GB0271	SPRING	RESORTE	FEDER	RESSORT
GB0473	RAIL ASSY (C) (US)	ASAMBLE DE CARRIL	SCHIENE-ZUSAMMENBAU	RAIL D'ASSEMBLÉE
GB0474	RAIL ASSY (B & AT) (US)	ASAMBLE DE CARRIL	SCHIENE-ZUSAMMENBAU	RAIL D'ASSEMBLÉE
GB0475	RAIL ASSY (C) (Euro)	ASAMBLE DE CARRIL	SCHIENE-ZUSAMMENBAU	RAIL D'ASSEMBLÉE
GB0476	RAIL ASSY (B & AT) (Euro)	ASAMBLE DE CARRIL	SCHIENE-ZUSAMMENBAU	RAIL D'ASSEMBLÉE
GB0512	LATCH	UNETA	VERSCHLUSS	DOIGT DE RETENUE
GB0526	RAIL ASSY (A & E) (US)	ASAMBLE DE CARRIL	SCHIENE-ZUSAMMENBAU	RAIL D'ASSEMBLÉE
GB0527	HOUSING (C)	ALOJAMIENTO	GEHÄUSE	CORPS
GB0528	HOUSING (G)	ALOJAMIENTO	GEHÄUSE	CORPS
GB0529	HOUSING (B)	ALOJAMIENTO	GEHÄUSE	CORPS
GB0530	HOUSING (F)	ALOJAMIENTO	GEHÄUSE	CORPS
GB0531	HOUSING (AT)	ALOJAMIENTO	GEHÄUSE	CORPS
GB0532	HOUSING (A)	ALOJAMIENTO	GEHÄUSE	CORPS
GB0533	HOUSING (E)	ALOJAMIENTO	GEHÄUSE	CORPS
GB0536	RAIL ASSY (A & E) (Euro)	ASAMBLE DE CARRIL	SCHIENE-ZUSAMMENBAU	RAIL D'ASSEMBLÉE
GC0735	PLATE	PLACA	PLATTE	PLAQUE
GC0755	FEEDER SHOE (C)	ALIMENTADOR	KLAMMERSCHIEBER	POUSSOIR
GC0756	ROLLER (B, F & AT)	RODILLO	ROLLE	GALET
GC0757	HOUSING (B & AT)	ALOJAMIENTO	GEHÄUSE	CORPS
GC0758	FEEDER SHOE (B & AT)	ALIMENTADOR	KLAMMERSCHIEBER	POUSSOIR
GC0759	ROLLER (C & G)	RODILLO	ROLLE	GALET
GC0763	RETAINER (B, C, F, G & AT)	JUNTA TÓRICA	SICHERUNGSRING	RETENUE
GC0769	RETAINER (A & E)	JUNTA TÓRICA	SICHERUNGSRING	RETENUE
GC0770	FEEDER SHOE (A & E)	ALIMENTADOR	KLAMMERSCHIEBER	POUSSOIR
GC0833	RETAINER	RETÉN	SICHERUNGSRING	RETENUE
HC0273	PIN	PASADOR	STIFT	GOUPILLE
HC0307	PIN	PASADOR	STIFT	GOUPILLE
HC0315	LEVER	PALANCA	HEBEL	LEVIER
HF0088	TRIGGER	GATILLO	AUSLÖSER	GACHETTE
HG0075	SAFETY LABEL (US)	ETIQUETA	AUFKLEBER	ÉTIQUETTE
HG0083	SAFETY LABEL (Euro)	ETIQUETA	AUFKLEBER	ÉTIQUETTE
KB0010	SCREW	TORNILLO	SCHRAUBE	VIS
KB0144	SCREW	TORNILLO	SCHRAUBE	VIS
KB0147	SCREW	TORNILLO	SCHRAUBE	VIS
KB0817	SCREW	TORNILLO	SCHRAUBE	VI
KB4293	SPRING	RESORTE	FEDER	RESSORT
KB4300	SPRING	RESORTE	FEDER	RESSORT
KB5144	PIN (B, F & AT)	PASADOR	STIFT	GOUPILLE
KB5145	PIN (C & G)	PASADOR	STIFT	GOUPILLE
KB5249	SCREW	TORNILLO	SCHRAUBE	VIS
LB0007	SEAL	SELLO	DICHTUNG	JOINT
LB0014	SEAL	SELLO	DICHTUNG	JOINT
LB0015	SEAL	SELLO	DICHTUNG	JOINT
LB0019	SEAL	SELLO	DICHTUNG	JOINT
LB0021	SEAL	SELLO	DICHTUNG	JOINT
LB0033	SEAL	SELLO	DICHTUNG	JOINT
LB0057	SEAL	SELLO	DICHTUNG	JOINT
LB0069	SEAL	SELLO	DICHTUNG	JOINT
LB0860	SEAL	SELLO	DICHTUNG	JOINT
LB0890	SEAL	SELLO	DICHTUNG	JOINT
LB0894	SEAL	SELLO	DICHTUNG	JOINT
LB0895	SEAL	SELLO	DICHTUNG	JOINT
LB0903	SEAL	SELLO	DICHTUNG	JOINT
LB5008	SEAL	SELLO	DICHTUNG	JOINT
LB5015	SEAL	SELLO	DICHTUNG	JOINT
LB5051	SEAL	SELLO	DICHTUNG	JOINT

Questions? Comments? call SENCO's toll-free Action-line: 1-800-543-4596 (North & South America only) or e-mail: toolprof@senco.com