

SLS15

ProSeries 18 Gauge Finish Stapler



The SLS15 finish stapler from SENCOR is both powerful and lightweight. The ergonomically correct design increases quality and productivity in a wide variety of applications.

Applications:

Cabinets, soffit, fascia, drawer assembly, picture frames, case backs, craft assembly

Features and Benefits:

- Adjustable depth-of-drive
- Rear exhaust – keeps oil and dust away from the work surface
- Easy-open latch – for quick loading
- Hardened steel driver – for extended life
- Full soft grip – for comfort and control
- Low load indicator – visible fastener indicator
- Available dual action or restrictive fire
- One-year warranty
- Includes case, fitting, oil, hex wrench and fastener rebate

Tool Specifications:

Tool Weight: 2.4 lbs (1.08 kg)
Height: 7.5" (190 mm)
Length: 10" (254 mm)
Staple Capacity: 100
Reg. Operating Pressure: 70-120 psig
Mode of Operation: Available with either Dual Action or Restrictive Trigger activating mechanisms

Fastener Specifications:

Gauge: 18
Crown: 1/4" (6.35 mm)
Fastener Range: 1/2" – 1"
Finish: Galvanized

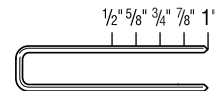



HARD WORK. BRING IT ON.™

SLS15

ProSeries 18 Gauge Finish Stapler

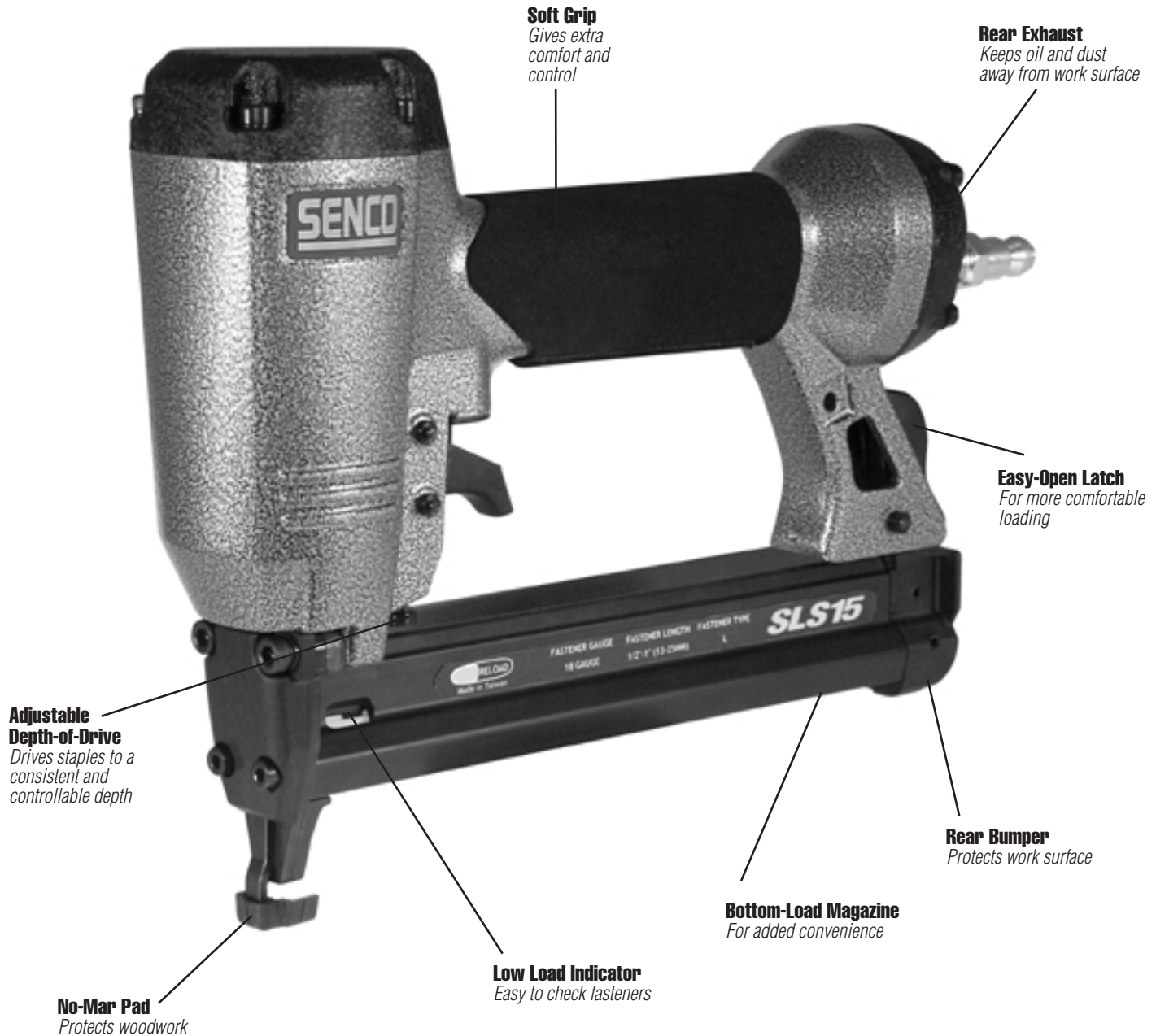

For additional information on how SENC Fastening Systems will save you time, reduce costs and increase quality, call your nearest Authorized SENC Dealer or Distributor listed in the Yellow Pages under "Nails," or call our toll-free Action Line: 1-800-543-4596.