

RYOBI®

OPERATOR'S MANUAL 3/8 in. (10 mm) Drill-Driver Model No. D40 DOUBLE INSULATED

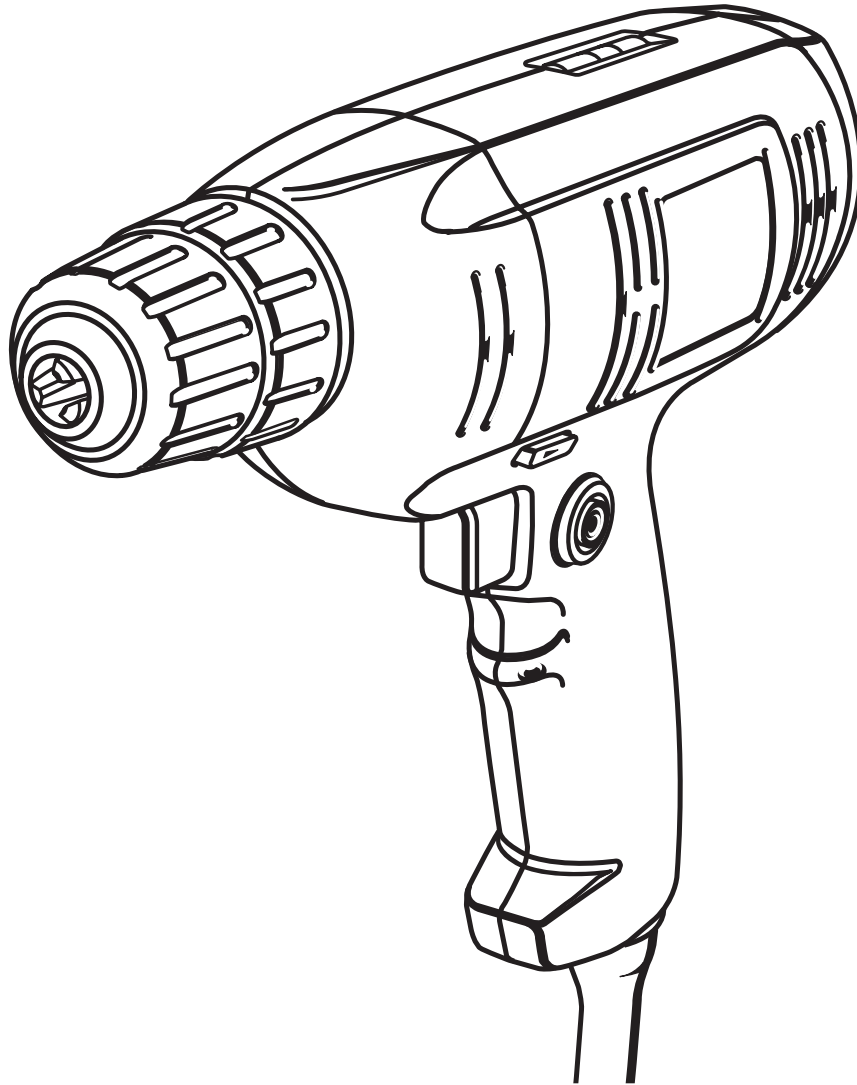

THANK YOU FOR BUYING A RYOBI DRILL-DRIVER

Your new drill has been engineered and manufactured to Ryobi's high standard for dependability, ease of operation, and operator safety. Properly cared for, it will give you years of rugged, trouble-free performance.



CAUTION: Carefully read through this entire operator's manual before using your new drill-driver.

Pay close attention to the Rules for Safe Operation, Warnings, and Cautions. If you use your drill properly and only for what it is intended, you will enjoy years of safe, reliable service.

Thank you again for buying Ryobi tools.

SAVE THIS MANUAL FOR FUTURE REFERENCE

TABLE OF CONTENTS

■ Table of Contents / Introduction	2
■ General Safety Rules	3-4
■ Specific Safety Rules	4
■ Symbols	5
■ Features	6-7
■ Operation	8-10
■ Maintenance	11
■ Exploded View and Repair Parts List	13
■ Parts Ordering / Service	14

INTRODUCTION

DOUBLE INSULATION

Your Ryobi power tool is double insulated. This means you are separated from the tool's electrical system by two complete sets of electrical insulation. This extra layer of insulation is intended to protect the user from electrical shock due to a break in the wiring insulation. All exposed metal parts are isolated from the internal metal motor components with protecting insulation. Double insulated tools do not need to be grounded.



WARNING:

The double insulated system is intended to protect the user from shock resulting from a break in the tool's internal wiring. Observe all normal safety precautions related to avoiding electrical shock.

IMPORTANT

Servicing of a tool with double insulation requires extreme care and knowledge of the system and should be performed only by a qualified service technician. For service we suggest you return the tool to your nearest **RYOBI AUTHORIZED SERVICE CENTER** for repair. When servicing use only identical Ryobi replacement parts.



WARNING:

Do not attempt to operate this tool until you have read thoroughly and understand completely all instructions, safety rules, etc. contained in this manual. Failure to comply can result in accidents involving fire, electric shock, or serious personal injury. Save owner's manual and review frequently for continuing safe operation, and instructing others who may use this tool.



WARNING:



The operation of any power tool can result in foreign objects being thrown into your eyes, which can result in severe eye damage. Before beginning tool operation, always wear safety goggles or safety glasses with side shields and a full face shield when needed. We recommend Wide Vision Safety Mask for use over eyeglasses or standard safety glasses with side shields. Always wear eye protection which is marked to comply with ANSI Z87.1.



Look for this symbol to point out important safety precautions. It means attention!!! Your safety is involved.

GENERAL SAFETY RULES



WARNING:

Read and understand all instructions. Failure to follow all instructions listed below, may result in electric shock, fire and/or serious personal injury.

SAVE THESE INSTRUCTIONS

Work Area

- **Keep your work area clean and well lit.** Cluttered benches and dark areas invite accidents.
- **Do not operate power tools in explosive atmospheres, such as in the presence of flammable liquids, gases, or dust.** Power tools may create sparks which may ignite the dust or fumes.
- **Keep bystanders, children, and visitors away while operating a power tool.** Distractions can cause you to lose control.

Electrical Safety

- **Double insulated tools are equipped with a polarized plug (one blade is wider than the other).** This plug will fit in a polarized outlet only one way. If the plug does not fit fully in the outlet, reverse the plug. If it still does not fit, contact a qualified electrician to install a polarized outlet. **Do not change the plug in any way.** Double insulation  eliminates the need for the three-wire grounded power cord and grounded power supply system.
- **Avoid body contact with grounded surfaces, such as pipes, radiators, ranges, and refrigerators.** There is an increased risk of electric shock if your body is grounded.
- **Don't expose power tools to rain or wet conditions.** Water entering a power tool will increase the risk of electric shock.
- **Do not abuse the cord. Never use the cord to carry the tools or pull the plug from an outlet. Keep cord away from heat, oil, sharp edges, or moving parts. Replace damaged cords immediately.** Damaged cords increase the risk of electric shock.
- **When operating a power tool outside, use an outdoor extension cord marked "W-A" or "W".** These cords are rated for outdoor use and reduce the risk of electric shock.

Personal Safety

- **Stay alert, watch what you are doing and use common sense when operating a power tool. Do not use tool while tired or under the influence of drugs, alcohol, or medication.** A moment of inattention while operating power tools may result in serious personal injury.

- **Dress properly. Do not wear loose clothing or jewelry. Contain long hair. Keep your hair, clothing, and gloves away from moving parts.** Loose clothes, jewelry, or long hair can be caught in moving parts.
- **Avoid accidental starting. Be sure switch is off before plugging in.** Carrying tools with your finger on the switch or plugging in tools that have the switch on, invites accidents.
- **Remove adjusting keys or wrenches before turning the tool on.** A wrench or a key that is left attached to a rotating part of the tool may result in personal injury.
- **Do not overreach. Keep proper footing and balance at all times.** Proper footing and balance enables better control of the tool in unexpected situations. Do not use on a ladder or unstable support.
- **Use safety equipment. Always wear eye protection.** Dust mask, nonskid safety shoes, hard hat, or hearing protection must be used for appropriate conditions.

Tool Use and Care

- **Use clamps or other practical way to secure and support the workpiece to a stable platform.** Holding the work by hand or against your body is unstable and may lead to loss of control.
- **Do not force tool. Use the correct tool for your application.** The correct tool will do the job better and safer at the rate for which it is designed.
- **Do not use tool if switch does not turn it on or off.** Any tool that cannot be controlled with the switch is dangerous and must be repaired.
- **Disconnect the plug from power source before making any adjustments, changing accessories, or storing the tool.** Such preventive safety measures reduce the risk of starting the tool accidentally.
- **Store idle tools out of the reach of children and other untrained persons.** Tools are dangerous in the hands of untrained users.
- **Maintain tools with care. Keep cutting tools sharp and clean.** Properly maintained tools with sharp cutting edges are less likely to bind and are easier to control.
- **Check for misalignment or binding of moving parts, breakage of parts, and any other condition that may affect the tool's operation. If damaged, have the tool serviced before using.** Many accidents are caused by poorly maintained tools.
- **Use only accessories that are recommended by the manufacturer for your model.** Accessories that may be suitable for one tool, may become hazardous when used on another tool.

GENERAL SAFETY RULES

Service

- **Tool service must be performed only by qualified repair personnel.** Service or maintenance performed by unqualified personnel could result in a risk of injury.
- **When servicing a tool, use only identical replacement parts. Follow instructions in the Maintenance section of this manual.** Use of unauthorized parts or failure to follow Maintenance Instructions may create a risk of electric shock or injury.

SPECIFIC SAFETY RULES

Hold tool by insulated gripping surfaces when performing an operation where the cutting tool may contact hidden wiring or its cord. Contact with a “live” wire will make exposed metal parts of the tool “live” and shock the operator.

Additional Rules For Safe Operation

- **Know your power tool.** Read operator’s manual carefully. Learn its applications and limitations, as well as the specific potential hazards related to this tool. Following this rule will reduce the risk of electric shock, fire, or serious injury.
- **Always wear safety glasses. Everyday eyeglasses have only impact-resistant lenses; they are NOT safety glasses.** Following this rule will reduce the risk of serious personal injury.
- **Protect your lungs. Wear a face or dust mask if the operation is dusty.** Following this rule will reduce the risk of serious personal injury.
- **Protect your hearing. Wear hearing protection during extended periods of operation.** Following this rule will reduce the risk of serious personal injury.
- **Inspect tool cords periodically and, if damaged, have repaired at your nearest Factory Service Center or other Authorized Service Organization. Constantly stay aware of cord location.** Following this rule will reduce the risk of electric shock or fire.
- **Check damaged parts. Before further use of the tool, a guard or other part that is damaged should be carefully checked to determine that it will operate properly and perform its intended function. Check for alignment of moving parts, binding of moving parts, breakage of parts, mounting, and any other conditions that may affect its operation. A guard or other part that is damaged should be properly repaired or replaced by an authorized service center.** Following this rule will reduce the risk of shock, fire, or serious injury.
- **Do not abuse cord. Never carry the tool by the cord or yank it to disconnect it from the receptacle. Keep cord away from heat, oil, and sharp edges.** Following this rule will reduce the risk of electric shock or fire.
- **Make sure your extension cord is in good condition. When using an extension cord, be sure to use one heavy enough to carry the current your product will draw. A wire gage size (A.W.G.) of at least 16 is recommended for an extension cord 100 feet or less in length. A cord exceeding 100 feet is not recommended. If in doubt, use the next heavier gage. The smaller the gage number, the heavier the cord.** An undersized cord will cause a drop in line voltage resulting in loss of power and overheating.
- **Inspect for and remove all nails from lumber before drilling.** Following this rule will reduce the risk of serious personal injury.
- **Drugs, alcohol, medication. Do not operate tool while under the influence of drugs, alcohol, or any medication.** Following this rule will reduce the risk of electric shock, fire, or serious personal injury.
- **Save these instructions. Refer to them frequently and use them to instruct others who may use this tool. If you loan someone this tool, loan them these instructions also.**

WARNING:



Some dust created by power sanding, sawing, grinding, drilling, and other construction activities contains chemicals known to cause cancer, birth defects or other reproductive harm. Some examples of these chemicals are:

- lead from lead-based paints,
- crystalline silica from bricks and cement and other masonry products, and
- arsenic and chromium from chemically-treated lumber.

Your risk from these exposures varies, depending on how often you do this type of work. To reduce your exposure to these chemicals: work in a well ventilated area, and work with approved safety equipment, such as those dust masks that are specially designed to filter out microscopic particles.

SYMBOLS

Important: Some of the following symbols may be used on your tool. Please study them and learn their meaning. Proper interpretation of these symbols will allow you to operate the tool better and safer.

SYMBOL	NAME	DESIGNATION/EXPLANATION
V	Volts	Voltage
A	Amperes	Current
Hz	Hertz	Frequency (cycles per second)
W	Watt	Power
min	Minutes	Time
~	Alternating Current	Type or a characteristic of current
n_0	No Load Speed	Rotational speed, at no load
	Class II Construction	Designates Double Insulated Construction tools
.../min	Revolutions or Reciprocation Per Minute	Revolutions, strokes, surface speed, orbits etc. per minute
	Safety Alert Symbol	Indicates danger, warning or caution. It means attention!!! Your safety is involved.

The purpose of safety symbols is to attract your attention to possible dangers. The safety symbols, and the explanations with them, deserve your careful attention and understanding. The safety warnings do not by themselves eliminate any danger. The instructions or warnings they give are not substitutes for proper accident prevention measures.

SYMBOL MEANING



SAFETY ALERT SYMBOL:

Indicates danger, warning, or caution. May be used in conjunction with other symbols or pictographs.



DANGER: Failure to obey a safety warning will result in serious injury to yourself or to others. Always follow the safety precautions to reduce the risk of fire, electric shock and personal injury.



WARNING: Failure to obey a safety warning can result in serious injury to yourself or to others. Always follow the safety precautions to reduce the risk of fire, electric shock and personal injury.



CAUTION: Failure to obey a safety warning may result in property damage or personal injury to yourself or to others. Always follow the safety precautions to reduce the risk of fire, electric shock and personal injury.

NOTE: Advises you of information or instructions vital to the operation or maintenance of the equipment.

SAVE THESE INSTRUCTIONS

FEATURES

KNOW YOUR DRILL-DRIVER

See Figure 1.

Before attempting to operate your drill, familiarize yourself with all operating features and safety requirements.

WARNING:

Carefully read through this entire operator's manual before using your new drill. Pay close attention to the Safety Rules, Warnings and Cautions. If you use your drill properly and only for what it is intended, you will enjoy years of safe, reliable service.

ELECTRICAL CONNECTION

Your drill has a precision built electric motor. It should be connected to a **power supply that is 120 volts, 60 Hz, AC only (normal household current)**. Do not operate this tool on direct current (DC). A substantial voltage drop will cause a loss of power and the motor will overheat. If your drill does not operate when plugged into an outlet, double-check the power supply.

WARNING:

Do not allow familiarity with your drill to make you careless. Remember that a careless fraction of a second is sufficient to inflict severe injury.

KEYLESS CHUCK

Your drill has a keyless chuck that allows you to hand tighten or release drill bit in the chuck jaws.

SWITCH

To turn your drill **ON**, depress the switch trigger. Release switch trigger to turn your drill **OFF**.

FORWARD/REVERSE SELECTOR (DIRECTION OF ROTATION SELECTOR)

Your drill has a forward/reverse selector located above the switch trigger.

VARIABLE SPEED

This tool has a variable speed switch that delivers higher speed with increased trigger pressure. Speed is controlled by the amount of switch trigger depression.

LEVEL

Two levels are recessed in the motor housing of your drill. They can be used to keep drill bits level during both horizontal and vertical drilling operations.

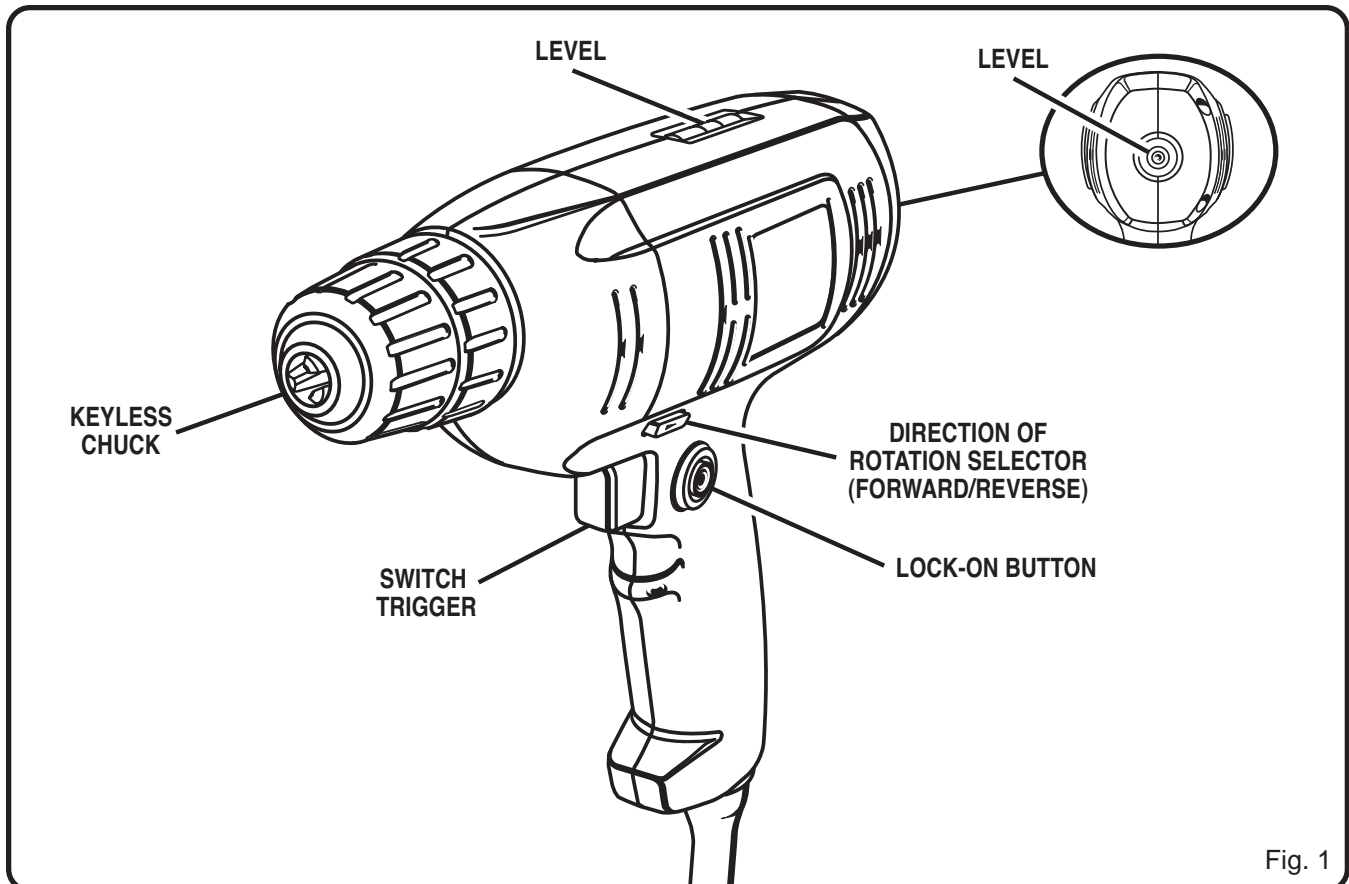

Fig. 1

FEATURES

PRODUCT SPECIFICATIONS:

DRILL-DRIVER

D40

Chuck Capacity	1/16 in. to 3/8 in. (1.6 mm to 10 mm)
Rating	120 V, 60 Hz, AC only
Input	4.5 Amperes
Switch	Variable Speed
No Load Speed	0-1400 RPM

APPLICATIONS

(Use only for the purpose listed below)

- Drilling in wood.
- Drilling in ceramics, plastics, fiberglass, and laminates.
- Drilling in both hard and soft metals.
- Using driving accessories, such as driving screws with screwdriver bits.
- Mixing paints.

WARNING:

If any parts are missing, do not operate your drill until the missing parts are replaced. Failure to do so could result in possible serious personal injury.

OPERATION

SWITCH

See Figure 2.

To turn your drill **ON**, depress the switch trigger. Release switch trigger to turn your drill **OFF**.

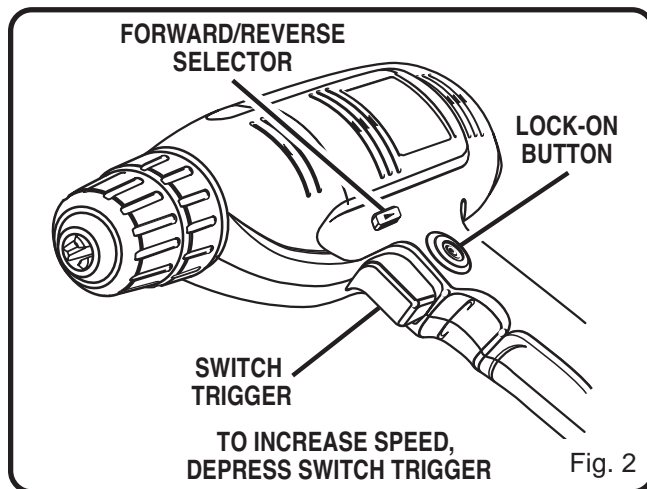

LOCK-ON BUTTON

See Figure 2.

Your drill is equipped with a lock-on feature which is convenient when continuous drilling for extended periods of time is required. To lock-on, depress the switch trigger, push in and hold the lock-on button located on the side of the handle, then release switch trigger. Release lock-on button and your drill will continue running. To release the lock, depress the switch trigger and release.

If you have the lock-on feature engaged during use and your drill becomes disconnected from power supply, disengage the lock-on feature immediately.

VARIABLE SPEED

See Figure 2.

Your drill has a variable speed switch designed to allow operator control of speed and torque limits. The speed and torque of your drill can be increased by depressing the switch trigger.

Note: Depress switch trigger all the way for maximum speed and torque of your drill. Depress switch trigger only part of the way for less speed and torque.

Avoid running your drill at low speeds for extended periods of time. Running at low speeds under constant usage may cause your drill to become overheated. If this occurs, cool your drill by running it without a load and at full speed.

The following guidelines may be used in determining correct speed for various applications:

- **Low** speed is ideal when minimum speed and power is required. For example, starting holes without center punching, driving screws, mixing paint, and drilling in ceramics.
- **Medium** speed is suitable for drilling hard metals, plastics, and laminates.
- **High** speed produces best results when maximum power is required. For example, drilling in wood; soft metals such as aluminum, brass, and copper, and when using driving accessories.

OPERATION

REVERSIBLE

See Figure 3.

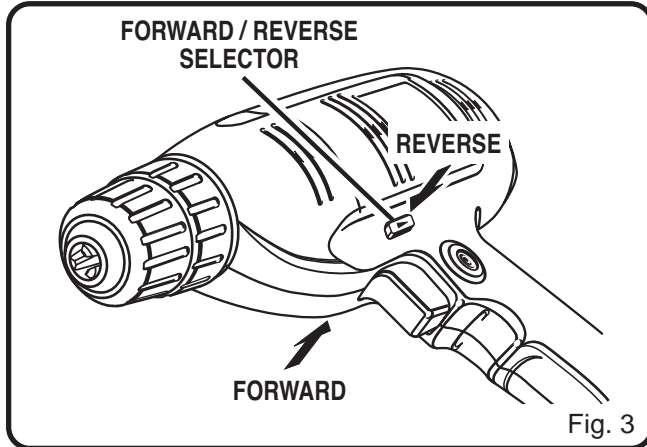

This tool has the feature of being reversible. The direction of rotation is controlled by a selector located above the switch trigger. With the drill held in normal operating position, the direction of rotation selector should be positioned to the left of the switch for drilling. The drilling direction is reversed when the selector is to the right of the switch.

⚠ CAUTION:

To prevent gear damage, always allow chuck to come to a complete stop before changing the direction of rotation.

To stop, release switch trigger and allow the chuck to come to a complete stop.

⚠ WARNING:

Your drill should never be connected to power supply when you are assembling parts, making adjustments, installing or removing drill bits, cleaning, or when not in use. Disconnecting your drill will prevent accidental starting that could cause serious personal injury.

KEYLESS CHUCK

See Figure 4.

A keyless chuck has been provided with your drill to allow for easy installation and removal of bits. As the name implies, you can hand tighten or release drill bits in the chuck jaws. Arrows on the chuck indicate which direction to rotate the chuck body in order to **LOCK** (tighten) or **UNLOCK** (release) the chuck jaws. Grasp and hold the collar of the chuck with one hand. Rotate the chuck body with your other hand. Insert drill bit straight into the chuck the full length of the jaws, and tighten securely by rotating the chuck body in a clockwise direction.

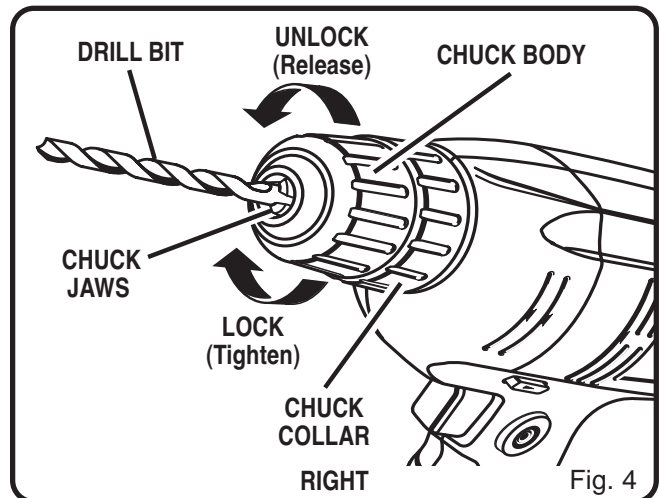

⚠ WARNING:

Do not hold chuck body with one hand and use power of the drill to tighten chuck jaws on drill bit. Chuck body could slip in your hand or your hand could slip and come in contact with rotating drill bit. This could cause an accident resulting in serious personal injury.

INSTALLING BITS

See Figure 4.

- Unplug your drill.

⚠ WARNING:

Failure to unplug your drill could result in accidental starting causing serious injury.

- Open or close the chuck jaws to a point where the opening is slightly larger than the bit size you intend to use. Also, raise the front of your drill slightly to keep the bit from falling out of the chuck jaws.
- Insert drill bit straight into chuck the full length of the jaws as shown in figure 4.
- Tighten the chuck jaws on drill bit.
- To tighten the chuck jaws on drill bit; grasp and hold the collar of the chuck with one hand, while rotating the chuck body with your other hand.

Note: Rotate the chuck body in the direction of the arrow marked **LOCK** to tighten chuck jaws.

- **Do not** use a wrench to tighten or loosen the chuck jaws.

OPERATION

⚠ WARNING:

Make sure to insert drill bit straight into chuck jaws. Do not insert drill bit into chuck jaws at an angle and then tighten, as shown in Figure 5. This could cause drill bit to be thrown from drill, resulting in possible serious personal injury or damage to the chuck.

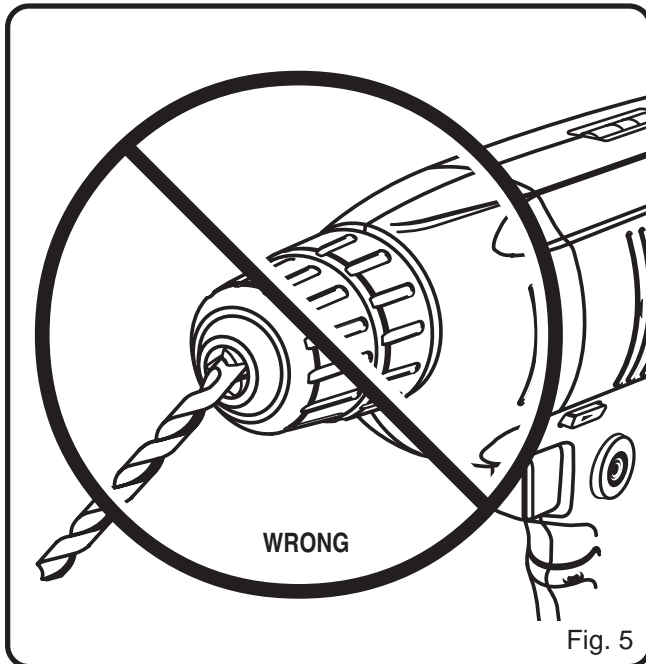

REMOVING BITS

See Figure 4.

- Unplug your drill.

⚠ WARNING:

Failure to unplug your drill could result in accidental starting causing serious injury.

- Loosen the chuck jaws from drill bit.
- To loosen: grasp and hold the collar with one hand, while rotating chuck body with your other hand.
Note: Rotate chuck body in the direction of the arrow marked **UNLOCK** to loosen chuck jaws.
- **Do not** use a wrench to tighten or loosen the chuck jaws.
- Remove drill bit from chuck jaws.

⚠ WARNING:

Always wear safety goggles or safety glasses with side shields when operating your drill. Failure to do so could result in dust, shavings, loose particles or foreign objects being thrown into your eyes, causing possible serious injury.

DRILLING

See Figure 6.

When drilling hard smooth surfaces use a center punch to mark desired hole location. This will prevent the drill bit from slipping off center as the hole is started. However, the low speed feature allows starting holes without center punching if desired. To accomplish this, simply operate your drill at a low speed until the hole is started.

The material to be drilled should be secured in a vise or with clamps to keep it from turning as the drill bit rotates.

Hold tool firmly and place the bit at the point to be drilled. Depress the switch trigger to start tool.

Move the drill bit into the workpiece applying only enough pressure to keep the bit cutting. Do not force or apply side pressure to elongate a hole.

⚠ WARNING:

Be prepared for binding or bit breakthrough. When these situations occur, drill has a tendency to grab and kick opposite to the direction of rotation and could cause loss of control when breaking through material. If not prepared, this loss of control can result in possible serious injury.

When drilling metals, use a light oil on the drill bit to keep it from overheating. The oil will prolong the life of the bit and increase the drilling action.

If the bit jams in workpiece or if the drill stalls, release switch trigger immediately. Remove the bit from the workpiece and determine the reason for jamming.

OPERATION

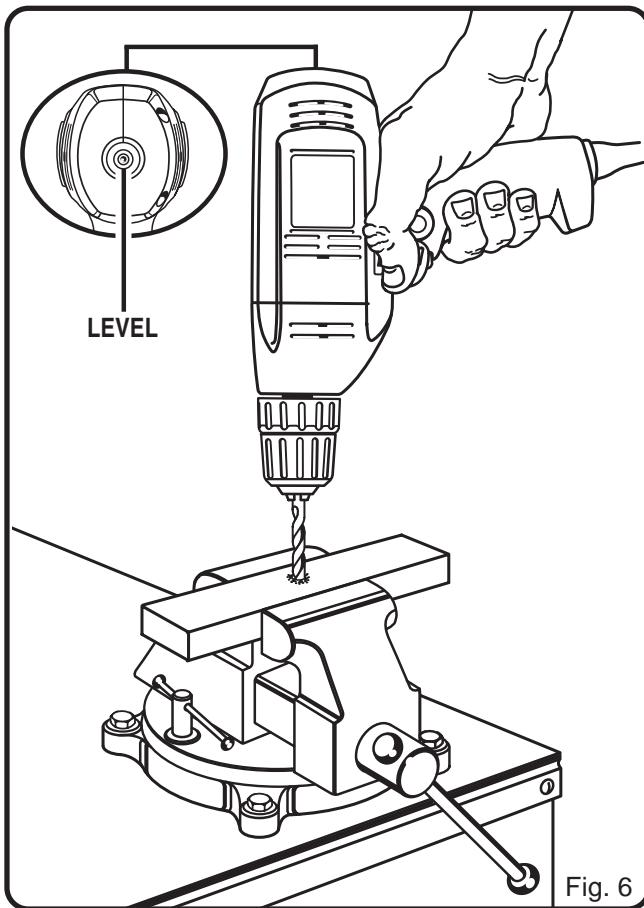

Fig. 6

LEVEL DRILLING

See Figures 6 and 7.

Two levels are recessed in the motor housing of your drill. One is located on top, while the other is located on the end. They can be used to keep drill bits level during both horizontal and vertical drilling operations.

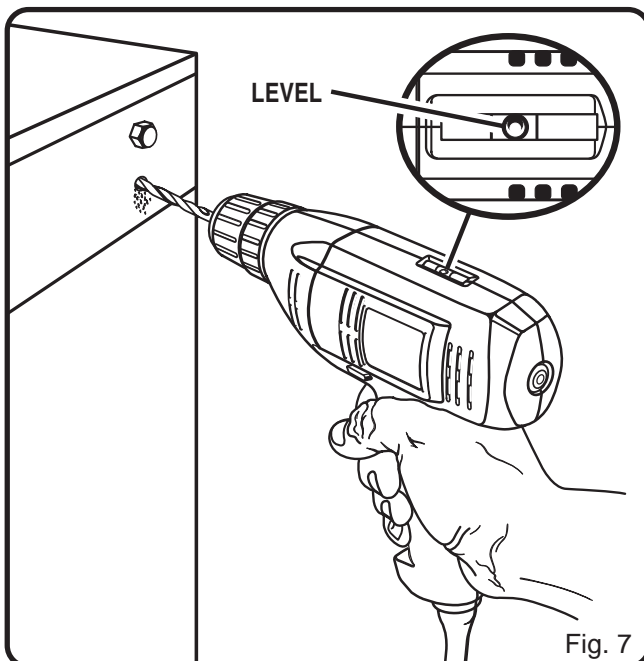

Fig. 7

CHUCK REMOVAL

See Figure 8.

Whenever necessary to remove the chuck for replacement, etc. use the following procedure:

- Unplug your drill.

⚠ WARNING:

Failure to unplug your drill could result in accidental starting causing serious injury.

- Rotate torque adjusting ring to the maximum torque setting.
- Insert a 8 mm (5/16 in.) or larger hex key into the chuck of your drill and tighten chuck jaws securely.
- Tap the hex key sharply with a mallet in a counterclockwise direction. See Figure 8.
- This will loosen the chuck on the spindle.
- It can now be unscrewed by hand. See Figure 8.
- Open chuck jaws and remove hex key.

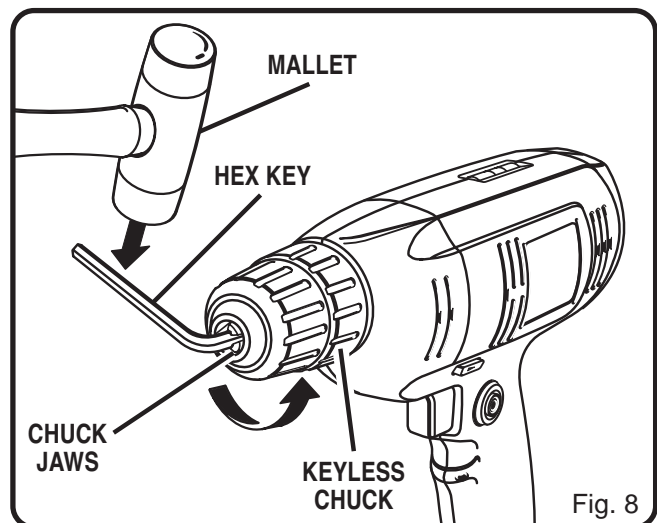

Fig. 8

TO RETIGHTEN A LOOSE CHUCK

The chuck may become loose on the spindle and develop a wobble.

To tighten, follow these steps:

- Unplug your drill.

⚠ WARNING:

Failure to unplug your drill could result in accidental starting causing serious injury.

- Open the chuck jaws.
- Insert hex key into chuck and tighten chuck jaws securely. Tap hex key sharply with a mallet in a clockwise direction.
- This will tighten the chuck on the spindle.
- Open the chuck jaws and remove the hex key.

MAINTENANCE

WARNING:

When servicing use only identical Ryobi replacement parts. Use of any other parts may create a hazard or cause product damage.

GENERAL

All parts represent an important part of the double insulation system and should be serviced only at an authorized service center.

Avoid using solvents when cleaning plastic parts. Most plastics are susceptible to damage from various types of commercial solvents and may be damaged by their use. Use clean cloths to remove dirt, carbon dust, etc.

WARNING:

Do not at any time let brake fluids, gasoline, petroleum-based products, penetrating oils, etc. come in contact with plastic parts. They contain chemicals that can damage, weaken or destroy plastic.

It has been found that electric tools are subject to accelerated wear and possible premature failure when they are used on fiberglass boats, sports cars, wallboard, spackling compounds, or plaster. The chips and grindings from these materials are highly abrasive to electric tool parts, such as bearings, brushes, commutators, etc. Consequently, it is not recommended that this tool be used for extended work on any fiberglass material, wallboard, spackling compounds, or plaster. During any use on these materials, it is extremely important that the tool is cleaned frequently by blowing with an air jet.

LUBRICATION

All of the bearings in this tool are lubricated with a sufficient amount of high-grade lubricant for the life of the unit under normal operating conditions. Therefore, no further lubrication is required.

WARNING:

Always wear safety goggles or safety glasses with side shields during power tool operation or when blowing dust. If operation is dusty, also wear a dust mask.

DOUBLE INSULATION

Double insulation is a concept in safety in electric power tools, which eliminates the need for the usual three-wire grounded power cord. All exposed metal parts are isolated from the internal metal motor components with protecting insulation. Double insulated tools do not need to be grounded.

IMPORTANT

Servicing of a tool with double insulation requires extreme care and knowledge of the system and should be performed only by a qualified service technician. For service, we suggest you return the tool to your nearest authorized service center for repair. Always use original factory replacement parts when servicing.

EXTENSION CORDS

The use of any extension cord will cause some loss of power. To keep the loss to a minimum and to prevent tool overheating, use an extension cord that is heavy enough to carry the current the tool will draw.

A wire gage size (A.W.G.) of at least **16** is recommended for an extension cord 100 feet or less in length. When working outdoors, use an extension cord that is suitable for outdoor use. The cord's jacket will be marked **WA**.

CAUTION:

Keep extension cords away from the drilling area and position the cord so that it will not get caught on lumber, tools, etc., during drilling operation.

WARNING:

Check extension cords before each use. If damaged replace immediately. Never use tool with a damaged cord since touching the damaged area could cause electrical shock resulting in serious injury.

Extension cords suitable for use with your drill are available at your nearest authorized service center.

RYOBI 3/8 in. DRILL-DRIVER – MODEL NO. D40

The model number will be found on a plate attached to the motor housing. Always mention the model number in all correspondence regarding your 3/8 in. DRILL-DRIVER or when ordering parts.

SEE BACK PAGE FOR PARTS ORDERING INSTRUCTIONS

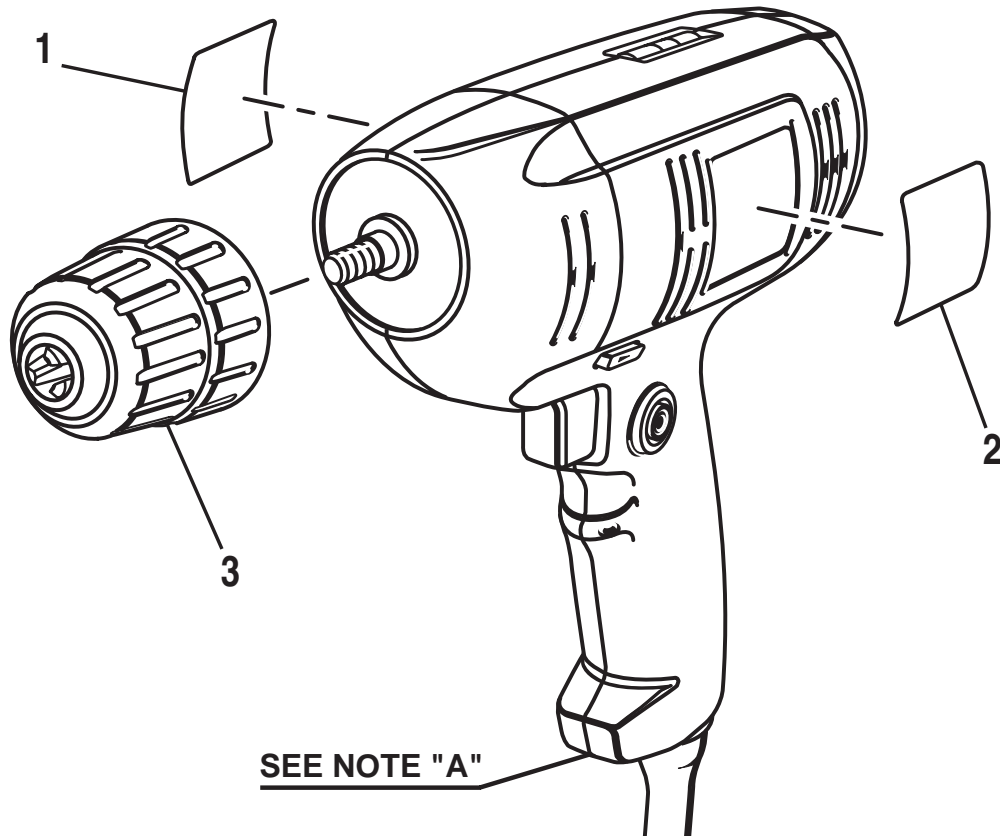

PARTS LIST

Key No.	Part No.	Description	Quan.
1	9418678	Data Plate	1
2	9418536	Logo Plate	1
3	6903201	3/8 in. Chuck	1
	983000-032	Operator's Manual	

NOTE: "A"– The assembly shown represents an important part of the Double Insulated System. To avoid the possibility of alteration or damage to the system, service should be performed by your nearest authorized service center.



OPERATOR'S MANUAL

3/8 in. (10 mm) Drill-Driver

Model No. D40

DOUBLE INSULATED

- **SERVICE**

Now that you have purchased your tool, should a need ever exist for repair parts or service, simply contact your nearest Ryobi Authorized Service Center. Be sure to provide all pertinent facts when you call or visit. Please refer to the insert or call 1-800-525-2579 in the United States or 1-800-265-6778 in Canada for your nearest Ryobi Authorized Service Center. You can also check our website at www.ryobitools.com for a complete list of Authorized Service Centers.

- **MODEL NO. AND SERIAL NO.**

The model number of this tool will be found on a plate attached to the motor housing. Please record the model number and serial number in the space provided below.

- **HOW TO ORDER REPAIR PARTS**

WHEN ORDERING REPAIR PARTS,
ALWAYS GIVE THE FOLLOWING INFORMATION:

- MODEL NUMBER D40
- SERIAL NUMBER _____

RYOBI TECHNOLOGIES, INC.

1428 Pearman Dairy Road Anderson SC 29625
Post Office Box 1207 Anderson SC 29622-1207
Phone 1-800-525-2579

RYOBI TECHNOLOGIES, INC.

P.O. Box 910
Cambridge, Ontario N1R 6K2
Phone 1-800-265-6778