

RYOBI® **OWNER'S OPERATOR'S MANUAL** **CORDLESS DRILL-DRIVER** **MODEL NO. HP61**

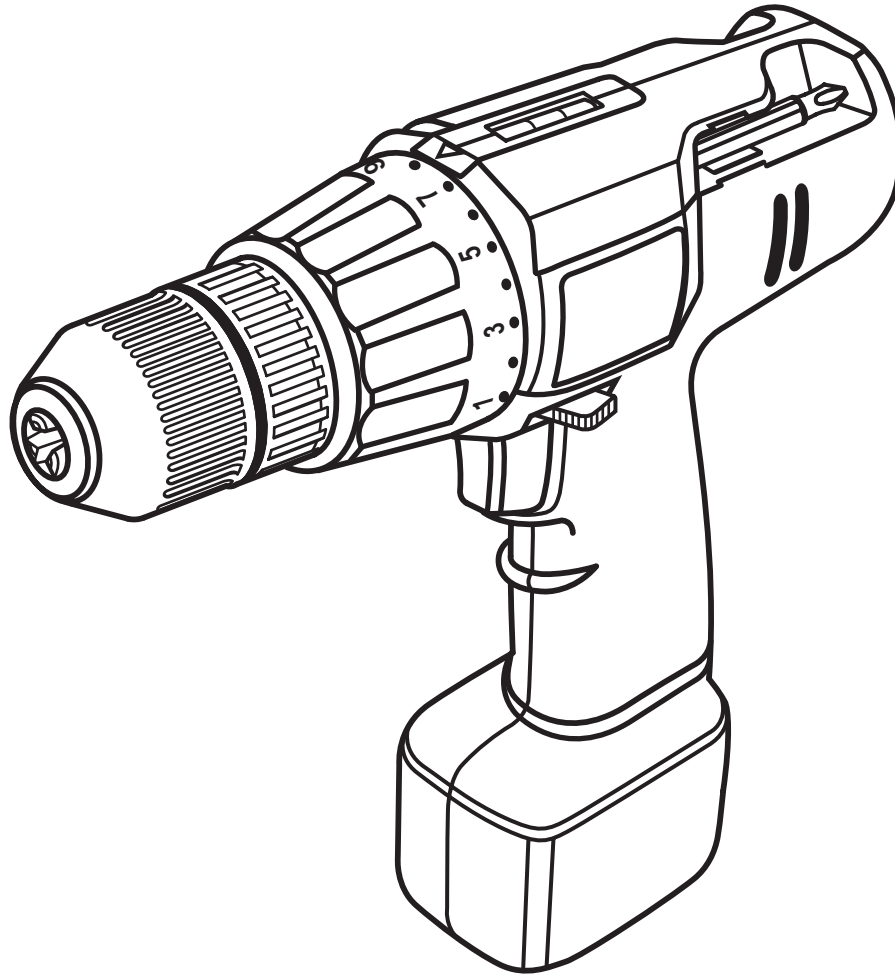

THANK YOU FOR BUYING A RYOBI CORDLESS DRILL-DRIVER.

Your new cordless drill-driver has been engineered and manufactured to Ryobi's high standard for dependability, ease of operation, and operator safety. Properly cared for, it will give you years of rugged, trouble-free performance.

⚠ CAUTION: Carefully read through this entire operator's manual before using your new cordless drill-driver.

Pay close attention to the Rules for Safe Operation, Warnings, and Cautions. If you use your cordless drill-driver properly and only for what it is intended, you will enjoy years of safe, reliable service.

Thank you again for buying Ryobi tools.

SAVE THIS MANUAL FOR FUTURE REFERENCE

TABLE OF CONTENTS

- Table Of Contents/Typical Applications 2
- Rules For Safe Operation 3-5
 - A. Precautions On Using Your Cordless Tool 4
 - B. Important Safety Instructions For Charger 4-5
 - C. Precautions Regarding The Use Of Charger And Batteries 5
- Operation 6-11
 - A. Specifications 6
 - B. Know Your Drill-Driver, Charging Your Drill-Driver 6
 - C. Important Information For Recharging Hot Batteries, Switch, Switch Lock, Reversible 7
 - D. Keyless Chuck, Installing Bits 8
 - E. Removing Bits, Screwdriving, Bit Storage, Level Drilling 9
 - F. Drilling 10
 - G. Chuck Removal, To Retighten a Loose Chuck 11
- Maintenance 12
- Battery Removal 13
 - A. Disposal Of Exhausted Batteries
 - B. Battery Removal, Preparation For Recycling 13
- Service Information 14

⚠ CAUTION: Carefully read through this entire manual before using your new drill-driver.

TYPICAL APPLICATIONS

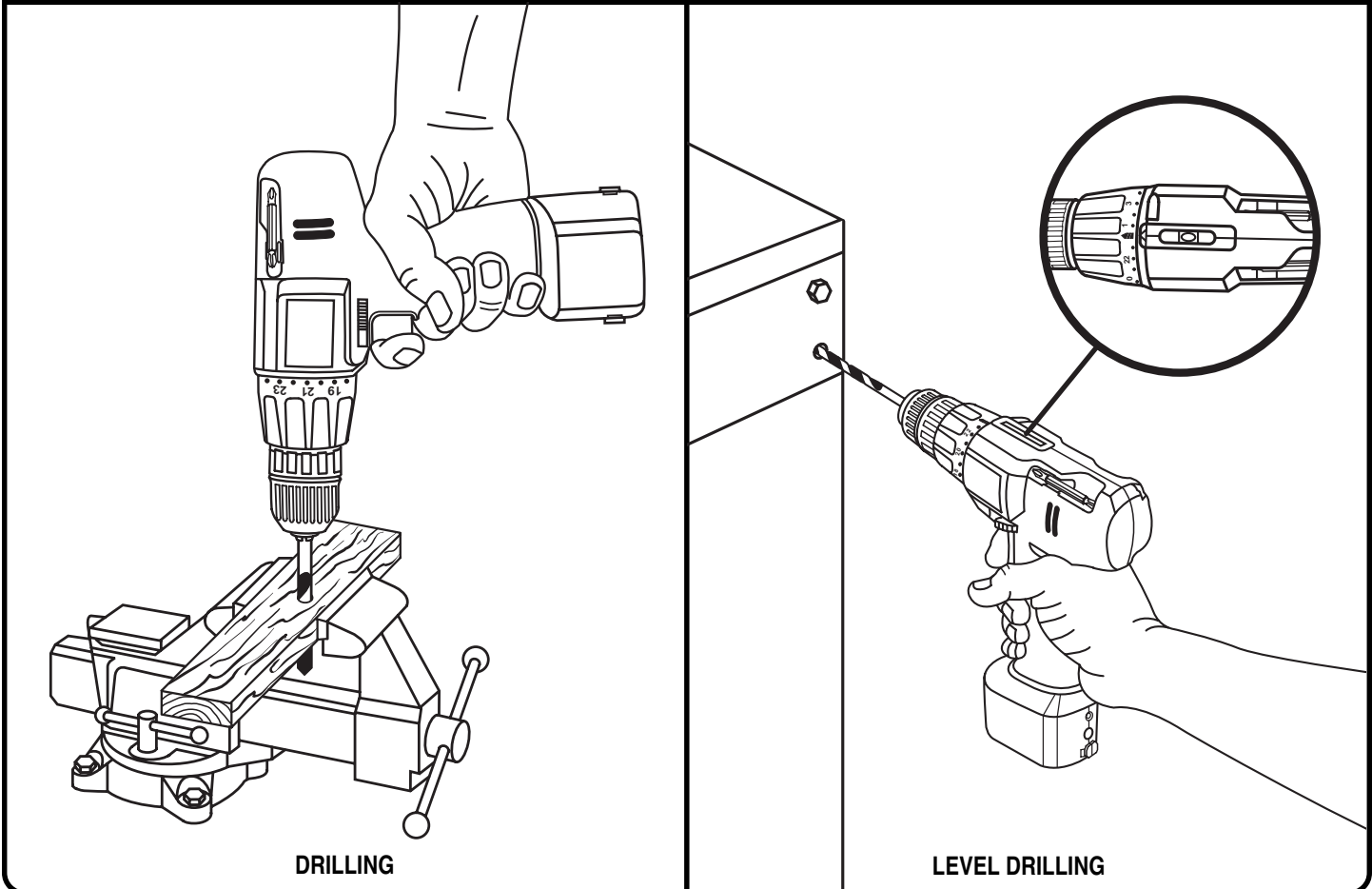

RULES FOR SAFE OPERATION

The purpose of safety symbols is to attract your attention to possible dangers. The safety symbols, and the explanations with them, deserve your careful attention and understanding. The safety warnings do not by themselves eliminate any danger. The instructions or warnings they give are not substitutes for proper accident prevention measures.

SYMBOL	MEANING
	SAFETY ALERT SYMBOL: Indicates danger, warning, or caution. May be used in conjunction with other symbols or pictographs.
	DANGER: Failure to obey a safety warning will result in serious injury to yourself or to others. Always follow the safety precautions to reduce the risk of fire, electric shock, and personal injury.
	WARNING: Failure to obey a safety warning can result in serious injury to yourself or to others. Always follow the safety precautions to reduce the risk of fire, electric shock and personal injury.
	CAUTION: Failure to obey a safety warning may result in property damage or personal injury to yourself or to others. Always follow the safety precautions to reduce the risk of fire, electric shock and personal injury.
NOTE:	Advises you of information or instructions vital to the operation or maintenance of the equipment.

**SAFETY ALERT SYMBOL:**

Indicates danger, warning, or caution. May be used in conjunction with other symbols or pictographs.



DANGER: Failure to obey a safety warning will result in serious injury to yourself or to others. Always follow the safety precautions to reduce the risk of fire, electric shock, and personal injury.



WARNING: Failure to obey a safety warning can result in serious injury to yourself or to others. Always follow the safety precautions to reduce the risk of fire, electric shock and personal injury.



CAUTION: Failure to obey a safety warning may result in property damage or personal injury to yourself or to others. Always follow the safety precautions to reduce the risk of fire, electric shock and personal injury.

NOTE: Advises you of information or instructions vital to the operation or maintenance of the equipment.

KNOW YOUR CORDLESS TOOL

Safe operation of this cordless tool requires that you read and understand this Operator's Manual and all labels affixed to the tool. Learn its applications and limitations as well as the potential hazards related to a cordless tool. Keep this manual readily available for future reference.

IMPORTANT

Servicing of a tool requires extreme care and knowledge of the system and should be performed only by a qualified service technician. For service we suggest you return the tool to your nearest **Authorized Service Center** for repair. When servicing, use only identical replacement parts.

**WARNING:**

Do not attempt to operate this tool until you have read thoroughly and understand completely all instructions, safety rules, etc. contained in this manual. Failure to comply can result in accidents involving fire, electric shock, or serious personal injury. Save this operator's manual and review it frequently for continuing safe operation, and instructing others who may use this tool.

**WARNING:**

When using power tools, basic safety precautions should always be followed to reduce the risk of fire, electric shock, and personal injury, including the following precautions.

READ ALL INSTRUCTIONS

1. **KEEP THE WORK AREA CLEAN.** Cluttered work areas and work benches invite injuries.
2. **CONSIDER WORK AREA ENVIRONMENT.** Keep work area well lit. Do not use tool in presence of flammable liquids or gases.
3. **GUARD AGAINST ELECTRICAL SHOCK BY PREVENTING BODY CONTACT WITH GROUNDED SURFACES.** For example: Pipes, radiators, ranges, refrigerator enclosures.
4. **KEEP CHILDREN AND VISITORS AWAY.** All visitors should wear safety glasses and be kept a safe distance from work area. Do not let visitors contact tool or extension cord.
5. **STORE IDLE TOOLS.** When not in use tools should be stored in a dry and high or locked-up place - out of the reach of children.
6. **DON'T FORCE TOOL.** It will do the job better and safer at the rate for which it was designed.
7. **USE RIGHT TOOL.** Don't force small tool or attachment to do the job of a heavy duty tool. Don't use tool for purpose not intended - for example - A circular saw should never be used for cutting tree limbs or logs.
8. **WEAR PROPER APPAREL.** Do not wear loose clothing or jewelry that can get caught in tool's moving parts and cause personal injury. Rubber gloves and nonskid footwear are recommended

RULES FOR SAFE OPERATION (Continued)

- when working outdoors. Wear protective hair covering to contain long hair and keep it from being drawn into nearby air vents.
- 9. ALWAYS WEAR SAFETY GLASSES.** Everyday eyeglasses have only impact-resistant lenses; they are **NOT** safety glasses.
 - 10. PROTECT YOUR LUNGS.** Wear a face mask or dust mask if operation is dusty.
 - 11. PROTECT YOUR HEARING.** Wear hearing protection during extended periods of operation.
 - 12. SECURE WORK.** Use clamps or a vise to hold work. It's safer than using your hand and it frees both hands to operate tool.
 - 13. DON'T OVERREACH.** Keep proper footing and balance at all times. Do not use on a ladder or unstable support.
 - 14. MAINTAIN TOOLS WITH CARE.** Keep tools sharp at all times, and clean for best and safest performance. Follow instructions for lubricating and changing accessories.
 - 15. REMOVE ADJUSTING KEYS AND WRENCHES.** Form habit of checking to see that keys and adjusting wrenches are removed from tool before turning it on.
 - 16. AVOID UNINTENTIONAL STARTING.** Do not carry the tool with your finger on the switch. Be sure switch is off when not in use.
 - 17. STAY ALERT.** Watch what you are doing and use common sense. Do not operate tool when you are tired. Do not rush.
 - 18. CHECK DAMAGED PARTS.** Before further use of the tool, a guard or other part that is damaged should be carefully checked to determine that it will operate properly and perform its intended function. Check for alignment of moving parts, binding of moving parts, breakage of parts, mounting, and any other conditions that may affect its operation. A guard or other part that is damaged should be properly repaired or replaced by an authorized service center unless indicated elsewhere in this instruction manual.
 - 19. DO NOT USE TOOL IF SWITCH DOES NOT TURN IT ON AND OFF.** Have defective switches replaced by an Authorized Service Center.
 - 20. DRUGS, ALCOHOL, MEDICATION.** Do not operate tool while under the influence of drugs, alcohol, or any medication.
 - 21. INSPECT FOR** and remove all nails from lumber before drilling.
 - 22. DO NOT CHARGE BATTERY TOOL IN A DAMP OR WET LOCATION.**

PRECAUTIONS ON USING YOUR CORDLESS TOOL

This product contains Nickel-Cadmium batteries which must be disposed of properly.

1. Be aware that this tool is always in an operating condition, because it does not have to be plugged into an electrical outlet.
2. First, charge the batteries.
3. When not in use, lock the switch.
4. When operating at a high place, be aware of things below you.
5. Before drilling into walls, ceilings, or floors, make sure that there are no concealed power cables inside.

WARNING:

Drilling into electrical wiring can cause drill bit and chuck to become electrically live. Do not touch the chuck or metal housing when drilling into a wall; grasp only the insulated handle(s) provided on the tool.

IMPORTANT SAFETY INSTRUCTIONS FOR CHARGER

1. **SAVE THESE INSTRUCTIONS.** This manual contains important safety and operating instructions for battery charger part number 4400001.
2. Before using battery charger, read all instructions and cautionary markings in the manual, on battery charger, and product using battery charger.

WARNING:

To reduce risk of injury, charge only nickel-cadmium type rechargeable batteries. Other types of batteries may burst causing personal injury and damage.

3. Do not expose charger to rain or snow.
4. Use of an attachment not recommended or sold by the battery charger manufacturer may result in a risk of fire, electric shock, or injury to persons.
5. To reduce risk of damage to electric plug and cord, pull by the plug rather than the cord when disconnecting charger.
6. Make sure cord is located so that it will not be stepped on, tripped over, or otherwise subjected to damage or stress.

RULES FOR SAFE OPERATION (Continued)

7. An extension cord should not be used unless absolutely necessary. Use of improper extension cord could result in a risk of fire and electric shock. If extension cord must be used, make sure:
 - a. That pins on plug of extension cord are the same number, size and shape as those of plug on charger.
 - b. That extension cord is properly wired and in good electrical condition; and
 - c. That wire size is large enough for AC ampere rating of charger as specified below:

Cord Length (Feet)	25 ft.	50 ft.	100 ft.
Cord Size (AWG)	16	16	16

Note: AWG = American Wire Gage
 8. Do not operate charger with a damaged cord or plug. Replace immediately.
 9. Do not operate charger if it has received a sharp blow, been dropped, or otherwise damaged in any way; take it to an **AUTHORIZED SERVICE CENTER**.
 10. Do not disassemble charger; take it to an **AUTHORIZED SERVICE CENTER** when service or repair is required. Incorrect reassembly may result in a risk of electric shock or fire.
 11. To reduce risk of electric shock, unplug charger from outlet before attempting any maintenance or cleaning. Turning off controls will not reduce this risk.
4. Do not charge by means of an engine generator or DC power source.
 5. Do not store the tool in locations where the temperature may reach or exceed 104° F (40° C), such as outside sheds or metal buildings in summer.
 6. Do not incinerate the tool, even if it is severely damaged or completely worn out. The batteries may explode in fire.
 7. Battery leakage may occur under conditions of extreme usage or temperature. If liquid comes in contact with skin, wash quickly with soap and water, then with lemon juice or vinegar. If liquid gets in your eyes, wash for at least 10 minutes and seek medical attention immediately.
 8. Do not short-circuit the battery.



WARNING:

Some dust created by power sanding, sawing, grinding, drilling, and other construction activities contains chemicals known to cause cancer, birth defects or other reproductive harm. Some examples of these chemicals are:

- lead from lead-based paints,
- crystalline silica from bricks and cement and other masonry products, and
- arsenic and chromium from chemically-treated lumber.

Your risk from these exposures varies, depending on how often you do this type of work. To reduce your exposure to these chemicals: work in a well ventilated area, and work with approved safety equipment, such as those dust masks that are specially designed to filter out microscopic particles.

PRECAUTIONS REGARDING THE USE OF CHARGER AND BATTERIES

1. Do not charge batteries when temperature is below 50° F (10° C) or above 95° F (35° C).
2. The charger is designed to operate on standard household electrical power. Do not attempt to use it on any other voltage.
3. Consecutive charging may cause overheating. If you need to recharge batteries consecutively, wait

SAVE THESE INSTRUCTIONS



Look for this symbol to point out important safety precautions. It means attention!!! Your safety is involved.

OPERATION

SPECIFICATIONS:

Chuck	3/8 in. Keyless
Motor	DC Motor 6.0V
Switch	Two-Speed
No Load Speed	300/500 RPM
Clutch	24 Positions
Charger Input	120V, 60 Hz, AC only
Charge Rate	3-6 Hours

KNOW YOUR DRILL-DRIVER

See Figure 1.

Before attempting to use any tool, familiarize yourself with all operating features and safety requirements.

WARNING:

Do not allow familiarity with tools to make you careless. Remember that a careless fraction of a second is sufficient to inflict severe injury.

CHARGING YOUR DRILL-DRIVER

This tool has been shipped in a low charge condition to prevent possible problems. Therefore, you should charge it at least 6 hours prior to use.

Note: Batteries will not reach full charge the first time they are charged. Allow several cycles (drilling followed by recharging) for them to become fully charged.

TO CHARGE

- Charge only with the charger provided.
- Connect charger to the tool by inserting charger plug into input jack. **Note:** As shown in figure 2, input jack is located at rear of tool.
- **Make sure power supply is normal house voltage, 120 volts, 60 Hz, AC only.**
- Connect charger to power supply.
- The charge indicator light (**LED**) indicator, which is located on rear of drill, will light up when charger is properly connected to power supply. This red light indicates your drill is charging and will remain on until charger is disconnected from power supply.

WARNING:



The operation of any power tool can result in foreign objects being thrown into your eyes, which can result in severe eye damage. Before beginning power tool operation, always wear safety goggles or safety glasses with side shields and a full face shield when needed. We recommend Wide Vision Safety Mask for use over eyeglasses or standard safety glasses with side shields.

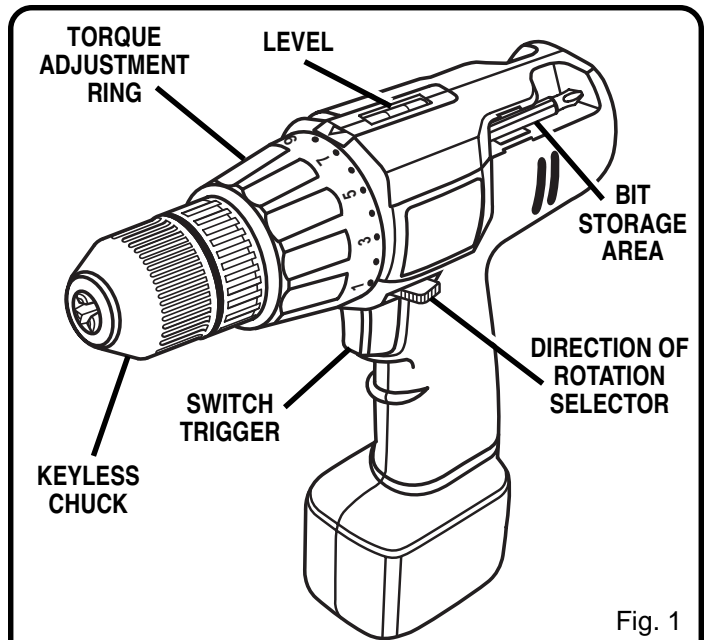

Fig. 1

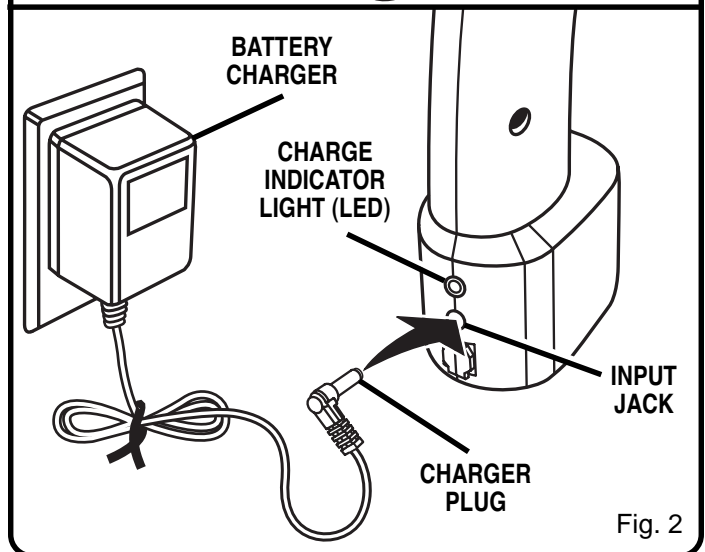

Fig. 2

- After normal usage, 3 hours of charging time is required to be fully charged. A minimum charge time of 6 hours is required to recharge a completely discharged battery.
- The charger housing and the tool handle will become slightly warm to the touch while charging. This is normal and does not indicate a problem.
- **DO NOT** operate drill while it is connected to the charger. The driving ability will not increase.
- **DO NOT** place charger in an area of extreme heat or cold. It works best at normal room temperature.

OPERATION

IMPORTANT INFORMATION FOR RECHARGING HOT BATTERIES

When using your drill-driver continuously, the batteries become hot. You should let the batteries cool down for approximately 30 minutes before attempting to recharge.

Note: This situation occurs when continuous use of your drill-driver causes the batteries to become hot. It does not occur under normal circumstances. Refer to "**Charging Your Drill-Driver**" for normal recharging of batteries. If the charger does not charge your batteries under normal circumstances, return **both** the drill-driver and charger to your nearest **AUTHORIZED SERVICE CENTER** for electrical check.

For more information on the battery recycling call **1-800-8 BATTERY**.

CAUTION:

Your drill contains special high temperature batteries to help prevent battery damage when left on charge for extended periods of time. However, once the batteries become fully charged, we recommend that you unplug your charger from power supply and disconnect it from drill.

WARNING:

If any parts are missing, do not operate tool until the missing parts are replaced. Failure to do so could result in possible serious personal injury.

SWITCH

See Figure 3.

Your drill starts and stops by depressing and releasing the switch trigger.

Your drill has a two-speed feature in the switch. Depress the switch trigger halfway for driving screws at low speed. Depress the switch trigger all the way for normal drilling. Release the switch trigger to turn drill **OFF**.

SWITCH LOCK

See Figure 3.

The switch trigger can be locked in the **OFF** position. This feature helps reduce the possibility of accidental starting when not in use. To lock the switch trigger, place the direction of rotation selector in the center position.

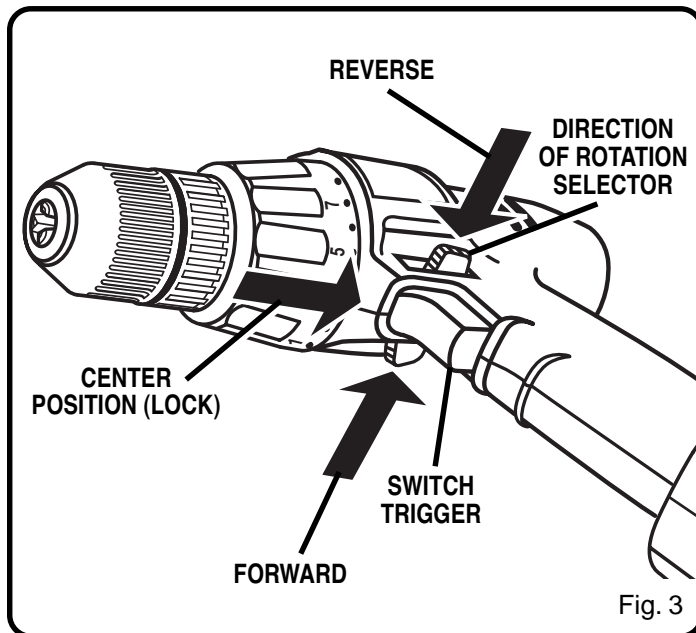

REVERSIBLE

See Figure 3.

This tool is reversible. The direction of rotation is controlled by a selector located above the switch trigger. With the drill held in normal operating position, the direction of rotation selector should be positioned to the left of the switch for drilling. The drilling direction is reversed when the selector is to the right of the switch. When the selector is in center position, the switch trigger is locked.

CAUTION:

To prevent gear damage, always allow chuck to come to a complete stop before changing the direction of rotation.

To stop, release switch trigger and allow the chuck to come to a complete stop.

WARNING:

Battery tools are always in operating condition. Therefore, switch should always be locked when not in use or when carrying at your side.

OPERATION

KEYLESS CHUCK

See Figure 4.

A keyless chuck has been provided with your drill to allow for easy installation and removal of bits. As the name implies, you can hand tighten or release drill bits in the chuck jaws. Grasp and hold the collar of the chuck with one hand. Rotate the chuck body with your other hand. The arrows on the chuck indicate which direction to rotate the chuck body in order to **GRIP** (tighten) or **RELEASE** (unlock) the drill bit.



WARNING:

Do not hold the chuck body with one hand and use the power of the drill to tighten chuck jaws on drill bit. Chuck body could slip in your hand or your hand could slip and come in contact with rotating drill bit. This could cause an accident resulting in serious personal injury.

INSTALLING BITS

- Place the direction of rotation selector in center position. This will turn off the power to your drill.
- Open or close the chuck jaws to a point where the opening is slightly larger than the bit size you intend to use. Also, raise the front of your drill slightly to keep the bit from falling out of the chuck jaws.
- Insert your drill bit into the chuck the full length of the jaws. See Figure 5.
- Tighten the chuck jaws on the drill bit. To tighten, grasp and hold the collar of the chuck with one hand, while rotating the chuck body with your other hand.

Note: Rotate the chuck body in the direction of the arrow marked **GRIP** to tighten the chuck jaws. **DO NOT** use a wrench to tighten or loosen the chuck jaws.



WARNING:

Do not insert drill bit into chuck jaws and tighten as shown in figure 6. This could cause drill bit to be thrown from drill resulting in possible serious personal injury or damage to the chuck.

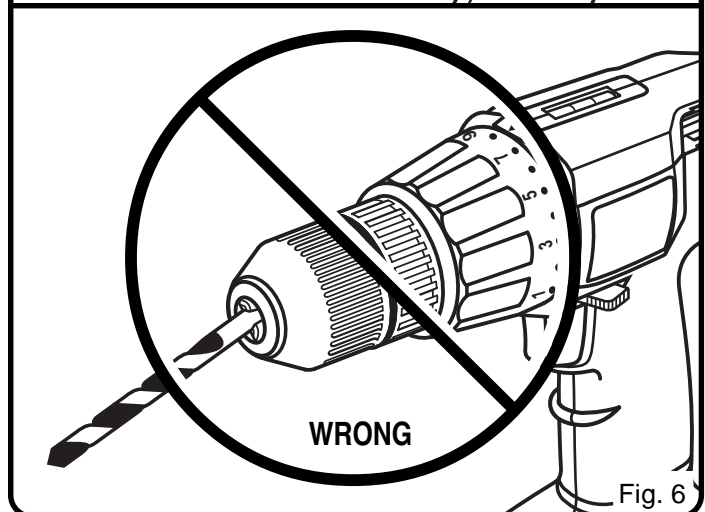
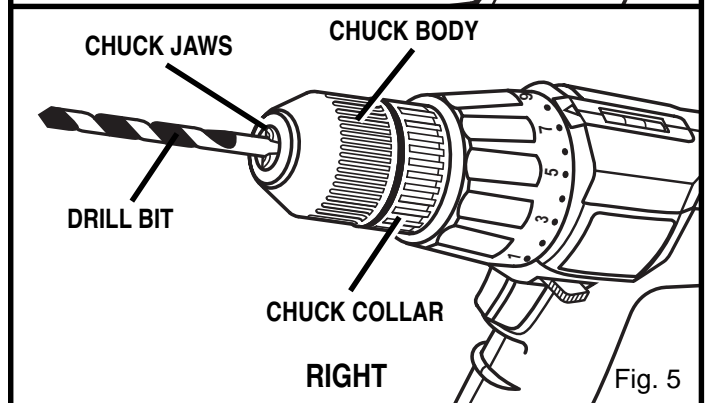
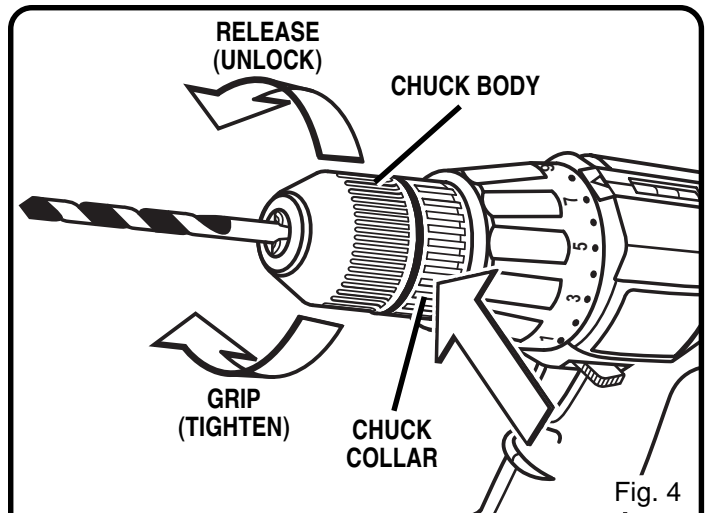

OPERATION

REMOVING BITS

See Figure 5.

- Place the direction of rotation selector in center position. This will turn off the power to your drill.
- Loosen the chuck jaws from drill bit.
- To loosen: grasp and hold the collar of the chuck with one hand, while rotating chuck body with your other hand.
Note: Rotate chuck body in the direction of the arrow marked **RELEASE** to loosen chuck jaws. **DO NOT** use a wrench to tighten or loosen the chuck jaws.
- Remove drill bit from chuck jaws.

SCREWDRIVING

TORQUE ADJUSTMENT

(Driving power of your drill-driver)

When using your drill-driver for various driving applications, it becomes necessary to increase or decrease the torque in order to help prevent the possibility of damaging screw heads, threads, workpiece, etc. In general, torque should correspond to the intensity of the screw diameter. If the torque is too high or the screws too small, the screws may be damaged or broken.

The torque is adjusted by rotating the torque adjustment ring. See Figure 7. The torque is greater when the torque adjustment ring is set on a higher setting. The torque is less when the torque adjustment ring is set on a lower setting.

The proper setting depends on the type of material and the size of screw you are using.

TO ADJUST TORQUE

- Identify the twenty four torque indicator settings located on the front of your drill. See Figure 7.
- Rotate adjustment ring to the desired setting.
 - 1 - 4 For driving small screws.
 - 5 - 8 For driving screws into soft material.
 - 9 - 12 For driving screws into soft and hard materials.
 - 13 - 16 For driving screws in hard wood.
 - 17 - 20 For driving large screws.
 - 21 - 24 For heavy drilling.

BIT STORAGE

See Figure 8.

When not in use, bits provided with your drill can be placed in the storage area located on the top of your drill as shown in figure 8.

LEVEL DRILLING

See Figure 9.

A convenient new feature provided with your drill is a level. It is recessed in the motor housing on top of your drill. It can be used to keep drill bit level during drilling operations.

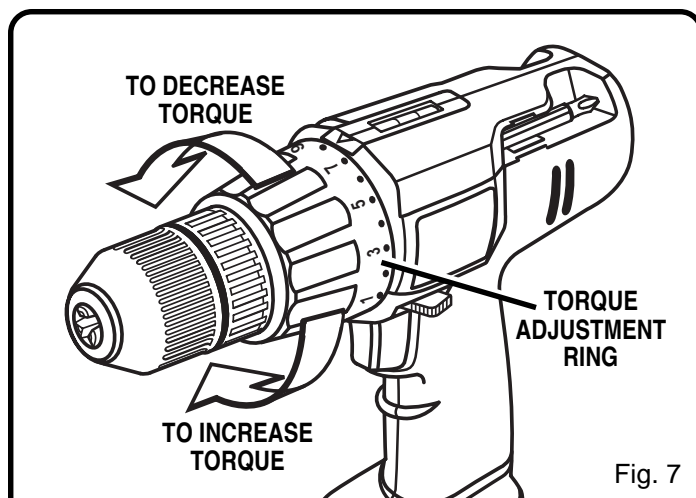

Fig. 7

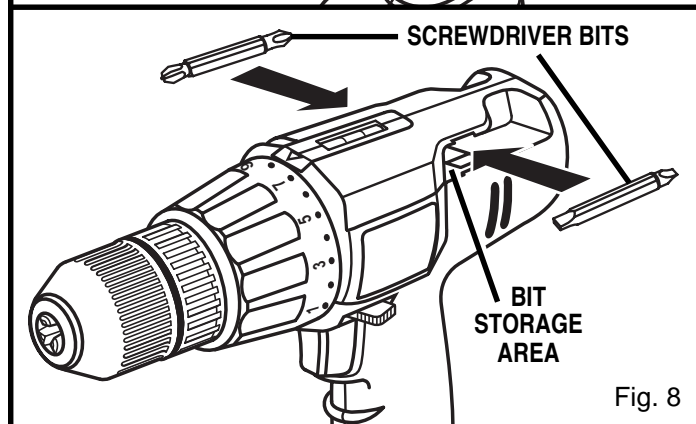

Fig. 8

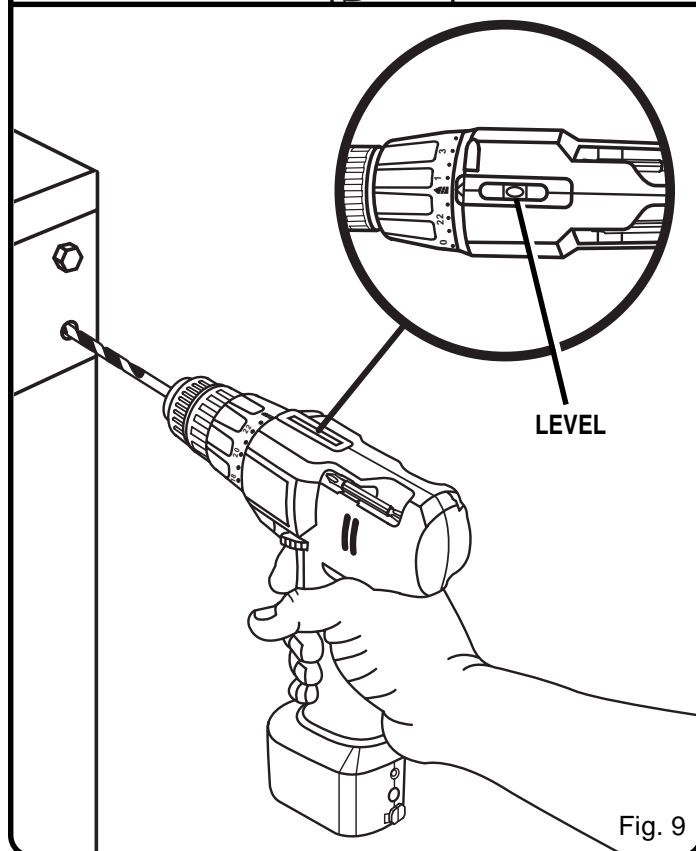

Fig. 9

OPERATION

WARNING:

Always wear safety goggles or safety glasses with side shields when operating tool. Failure to do so could result in objects being thrown into your eyes, resulting in possible serious injury.

DRILLING

See Figure 10.

When drilling hard, smooth surfaces, use a center punch to mark the desired hole location. This will prevent the drill bit from slipping off center as the hole is started. However, the lower speed feature allows starting holes without center punching if desired. To accomplish this, simply operate your drill at lower speed until the hole is started.

The material to be drilled should be secured in a vise or with clamps to keep it from turning as the drill bit rotates.

Hold tool firmly and place the bit at the point to be drilled. Depress the switch trigger to start tool.

Move the drill bit into the workpiece, applying only enough pressure to keep the bit cutting. Do not force or apply side pressure to elongate a hole.

WARNING:

Be prepared for binding or breakthrough. When these situations occur, the drill has a tendency to grab and kick in the opposite direction, and could cause loss of control when breaking through material. If you are not prepared, this loss of control can result in possible serious injury.

When drilling metals, use a light oil on the drill bit to keep it from overheating. The oil will prolong the life of the bit and increase the drilling action.

If the bit jams in workpiece or if the drill stalls, release switch trigger immediately. Remove the bit from the workpiece and determine the reason for jamming.

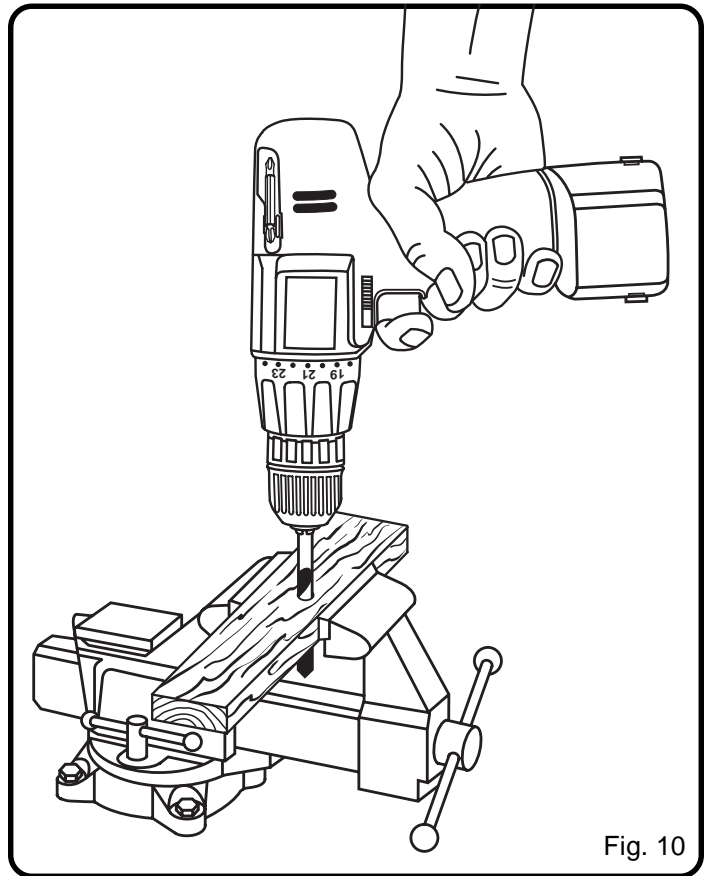

Fig. 10

OPERATION

CHUCK REMOVAL

See Figures 11, 12, and 13.

The chuck must be removed in order to use some accessories. To remove:

- Lock the switch trigger by placing the direction of rotation selector in center position.
- Insert a 5/16 inch or larger hex key wrench into the chuck of your drill and tighten the chuck jaws securely.
- Tap the hex key wrench sharply with a mallet in a clockwise direction. See Figure 11. This will loosen the screw in the chuck for easy removal.
- Open chuck jaws and remove hex key wrench. Remove the chuck screw by turning it in a clockwise direction. See Figure 12. **Note:** The screw has left hand threads.
- Insert hex key wrench in chuck and tighten chuck jaws securely. Tap sharply with a mallet in a counterclockwise direction. This will loosen chuck on the spindle. It can now be unscrewed by hand. See Figure 13.

TO RETIGHTEN A LOOSE CHUCK

The chuck may become loose on spindle and develop a wobble. Also, the chuck screw may become loose causing the chuck jaws to bind and prevent them from closing. To tighten, follow these steps:

- Lock the switch trigger by placing the direction of rotation selector in center position.
- Insert hex key wrench into chuck and tighten chuck jaws securely. Tap hex key wrench sharply with a mallet in a clockwise direction. This will tighten chuck on the spindle.
- Open the chuck jaws and remove hex key wrench.
- Tighten the chuck screw. **Note:** The chuck screw has left hand threads.

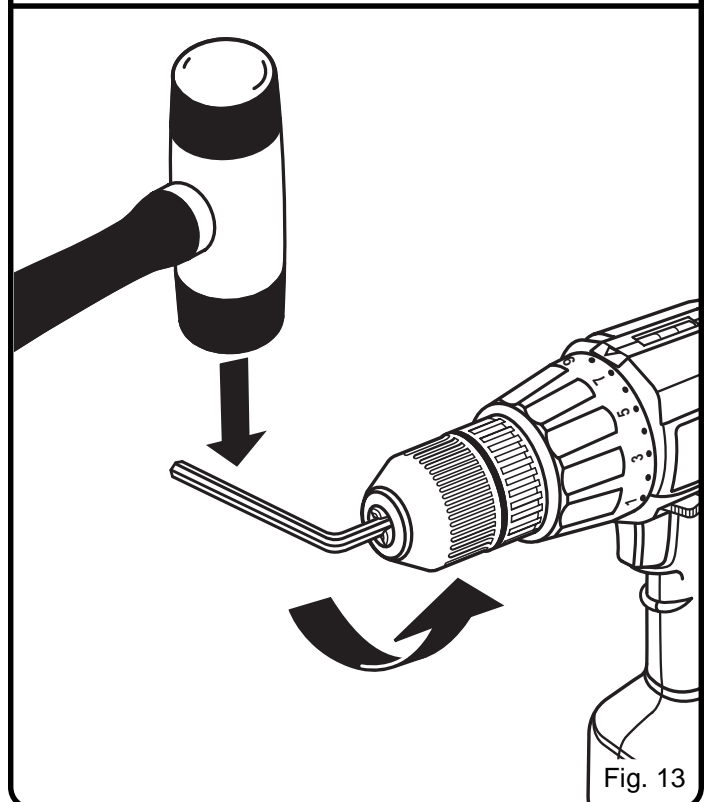
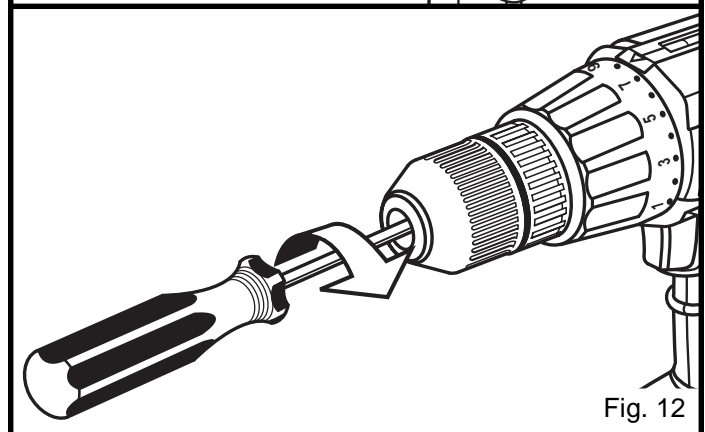
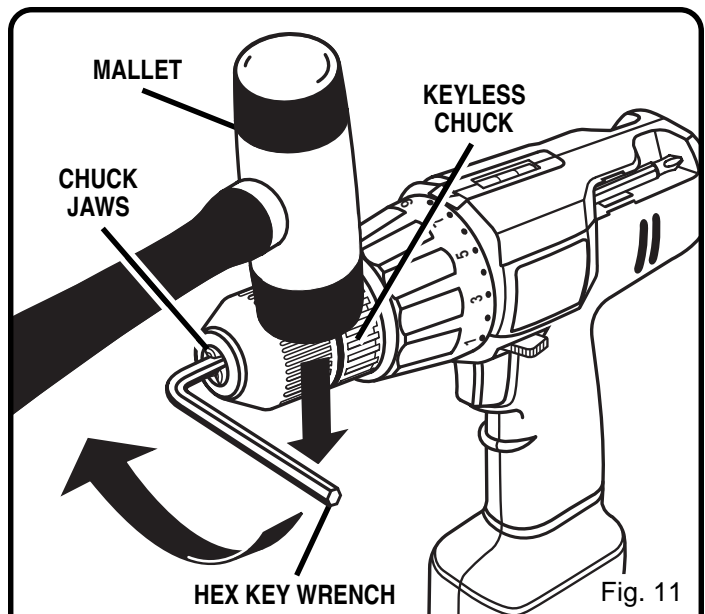

MAINTENANCE

BATTERIES

Your drill is equipped with Nickel-Cadmium rechargeable batteries. Length of service from each charging will depend on the type of work you are doing.

The batteries in this tool have been designed to provide maximum trouble-free life. However, like all batteries, they will eventually wear out. **Do not disassemble your drill and attempt to replace the batteries.** Handling of these batteries, especially when wearing rings and jewelry, could result in a serious burn.

To obtain the longest possible battery life, we suggest the following:

- Store and charge your batteries in a cool area. Temperatures above normal room temperature will shorten battery life.
- Never store batteries in a discharged condition. Wait for the batteries to cool and charge immediately.
- All batteries gradually lose their charge. The higher the temperature, the quicker they lose their charge. If you store your tool for long periods of time without using it, recharge the batteries every month or two. This practice will prolong battery life.

CAUTION:

Your drill-driver contains special high temperature batteries to help prevent battery damage when left on charge for extended periods of time. However, once the batteries become fully charged, we recommend that you unplug the charger from power supply and remove it from drill-driver.

WARNING:

When servicing use only identical replacement parts. Use of any other parts may create a hazard or cause product damage.

Avoid using solvents when cleaning plastic parts. Most plastics are susceptible to damage from various types of commercial solvents and may be damaged by their use. Use a clean cloth to remove dirt, oil, grease, etc.

WARNING:

Do not at any time let brake fluids, gasoline, petroleum-based products, penetrating oils, etc., come in contact with plastic parts. They contain chemicals that can damage, weaken, or destroy plastics.

DO NOT ABUSE POWER TOOLS. Abusive practices can damage the tool, as well as the work piece.

WARNING:

Do not attempt to modify this tool or create accessories not recommended for use with this tool. Any such alteration or modification is misuse and could result in a hazardous condition leading to possible serious personal injury.

CAUTION:

Any repairs requiring disassembly should only be performed by an **AUTHORIZED SERVICE CENTER**. For the repair center nearest you, call **1-800-525-2579**.

BATTERY REMOVAL

DISPOSAL OF EXHAUSTED BATTERIES



To preserve natural resources, please recycle or dispose of batteries properly.

This product contains nickel-cadmium battery. Local, state, or federal laws may prohibit disposal of Nickel-Cadmium batteries in ordinary trash.

Consult your local waste authority for information regarding available recycling and/or disposal options.

For more information on battery recycling call **1-800-8 BATTERY**.



WARNING:

Do not attempt to disassemble batteries. Fire or injury may result.

BATTERY REMOVAL, PREPARATION FOR RECYCLING

See Figures 14 and 15.

TO REMOVE:

- Lock switch trigger by placing the forward/reverse switch in center position.
- Remove battery cover from bottom of drill handle by depressing and pushing cover in the direction of the arrow as shown in figure 14.
- Slide battery assembly from drill handle enough to expose leads and battery terminals. See Figure 15. Disconnect leads from battery terminals.

Note: Be careful not to break battery terminals when disconnecting leads.



WARNING:

Upon removal, cover the battery assemblies terminals with heavy duty adhesive tape. Do not attempt to destroy or disassemble battery assembly or remove any of its components. Also, never touch both terminals with metal objects and/or body parts, as short circuit may result. Keep away from children. Failure to comply with these warnings could result in fire and/or serious injury.

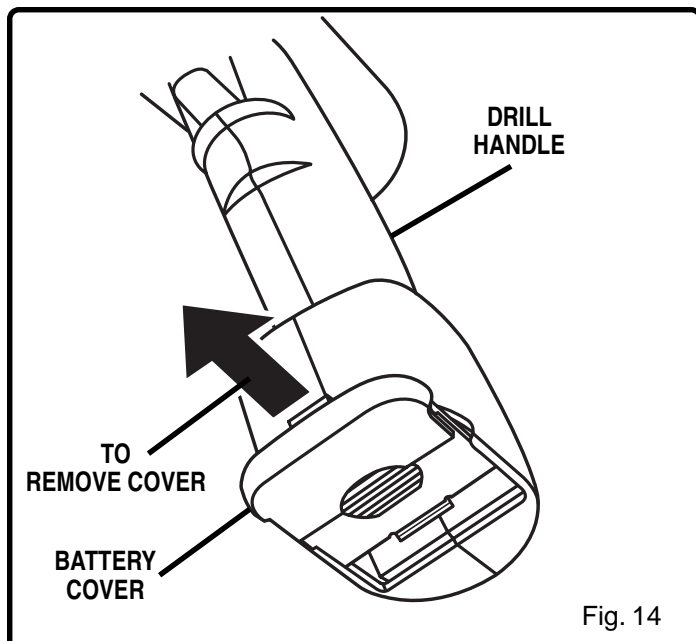

Fig. 14

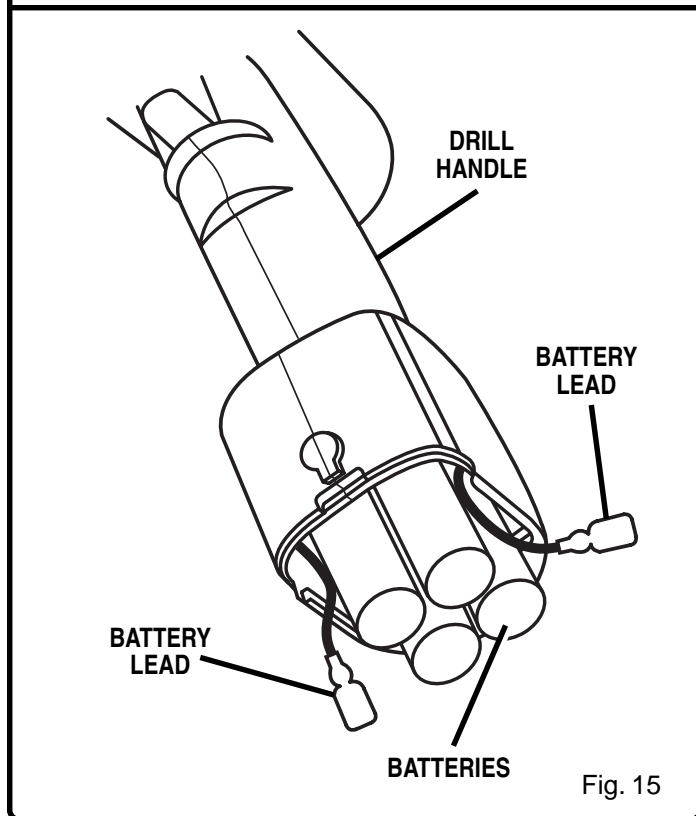

Fig. 15



OWNER'S OPERATOR'S MANUAL CORDLESS DRILL-DRIVER MODEL NO. HP61

- **SERVICE**

Now that you have purchased your tool, should a need ever exist for repair parts or service, simply contact your nearest Authorized Service Center. Be sure to provide all pertinent facts when you call or visit. Please refer to the Service Center insert or call 1-800-525-2579 in the United States or 1-800-265-6778 in Canada for your nearest Authorized Service Center. You can also check our web site at www.ryobi.com for a complete list of Authorized Service Centers.

- **MODEL NO. AND SERIAL NO.**

The model number of this tool will be found on a plate attached to the motor housing. Please record the model number and serial number in the space provided below.

- **HOW TO ORDER REPAIR PARTS**

WHEN ORDERING REPAIR PARTS,
ALWAYS GIVE THE FOLLOWING INFORMATION:

- MODEL NUMBER HP61
- SERIAL NUMBER _____

RYOBI AMERICA CORP.

1424 Pearman Dairy Road Anderson, SC 29625
Post Office Box 1207 Anderson, SC 29622-1207
Phone 1-800-525-2579

RYOBI CANADA INC.

Post Office Box 910
Cambridge, Ontario N1R 6K2
Phone 1-800-265-6778