

Thermal Carafe Coffee Brewer Pourover and Automatic



**Model
CW15-TC**

(no warmers) (thermal carafe sold separately)
Dimensions: 17.9" H x 9" W x 18.5" D
(45.5cm H x 22.9cm W x 55.4cm D)



**Model
CWTF15-TC**



Model CDBCF15-TC

Shown with Thermal Carafe
(no warmers) (thermal carafe sold separately)
Dimensions: 17.9" H x 9" W x 18.5" D
(45.5cm H x 22.9cm W x 55.4cm D)

Features

12 Cup Pourover and Automatic Coffee Brewer, CW-TC & CWTF-TC

- Brews 3.9 to 6.8 gallons (14.78 to 25.77 liters) of perfect coffee per hour.
- Accepts thermal carafe up to 8.5" tall (21.6cm).
- Use in quick turn environment where high quality coffee is continuously refreshed.
- Models are space saving 9.0" wide (22.9cm).
- All stainless steel construction.
- Hot water faucet available on automatics
- SplashGard® funnel deflects hot liquids away from the hand.
- Pourover model requires no plumbing and is completely portable. Just pour cold water in top and coffee brews immediately.

12 Cup Automatic Coffee Brewer, CDBCF

- Automatically adjusts to varying water pressure.
- Quicker install with pot level, cold brew lock-out and tank temperature set using the simple-to-program touch pad controls.
- Faster service by use of feedback information from built-in electronic diagnostics.

For current specification sheets and other information, go to www.bunn.com.

** International models may vary in appearance.*

Related Products

Easy Clear® EQ-17-TL

Product No. : 30200.1000
Dimensions:
12 $\frac{7}{16}$ " H x 2 $\frac{1}{2}$ " W x 3" D
31.6 cm H x 6.35 cm W x 7.62 cm D



Thermal Carafe

Product No. : 18022.6002
Capacity 1.9 liter (64 oz)
Dimensions: 8"H x 6.4"W x 8.2"D
(20.3cm H x 16.3cm W x 21cm D)



Paper Filter Pack

Product No. : 20115.6000
Packed per case: 1,000
Dimensions: 4 $\frac{1}{4}$ " Base x 2 $\frac{3}{4}$ " Sidewall
10.8 cm Base x 6.98 cm Sidewall



Model

Agency Listing

CWTF15-TC
CDBCF15-TC



CW15-TC



Dimensions & Specifications



Model	Product #	Volts	Amps	Tank Htr Watts	Total Watts	Capacity per hour	Cubic ft ³ /m ³	Weight lbs/kg	Cord Attached
CW15-TC	23001.6057	120	12.1	1450	1450	3.9 gal/14.78 liter	6.3/.178	28 / 12.7	Yes**
CW15-TC*	23001.6058	120	12.1	1450	1450	3.9 gal/14.78 liter	6.3/.178	28 / 12.7	Yes**
CWTF15-TC*	12950.6104	120	12.1	1450	1450	3.9 gal/14.78 liter	6.3/.178	35 / 15.9	Yes**
CWTF35-TC	12950.6107	120/240	14.6	3500	3500	6.8 gal/25.77 liter	5.1/.144	34 / 15.4	No
CDBCF15-TC*	29000.6012	120	12.5	1450	1500	4.2 gal/15.92 liter	5.1/.144	31 / 14.1	Yes**
CDBCF35-TC*	29000.6015	120/240	14.6	3500	3500	6.8 gal/25.77 liter	5.1/.144	29 / 13.2	No

* Includes a stainless steel funnel **Power cord (NEMA 5-15P) 15 Amp-120V machine only.

Brewing capacity: based upon incoming water temp of 60°F (140°F rise) per 1/2 gallon brew time of 4 minutes.

Models listed as 120/208V or 120/240V must be connected to 208V or 240V electrical service respectively. Please refer to the installation manual.

Electrical: Requires 2-wires plus ground service rated 120V single phase, 60 Hz.

Plumbing: 20-90 psi (138-621 kPa). Machine supplied with 1/4" male flare fitting.

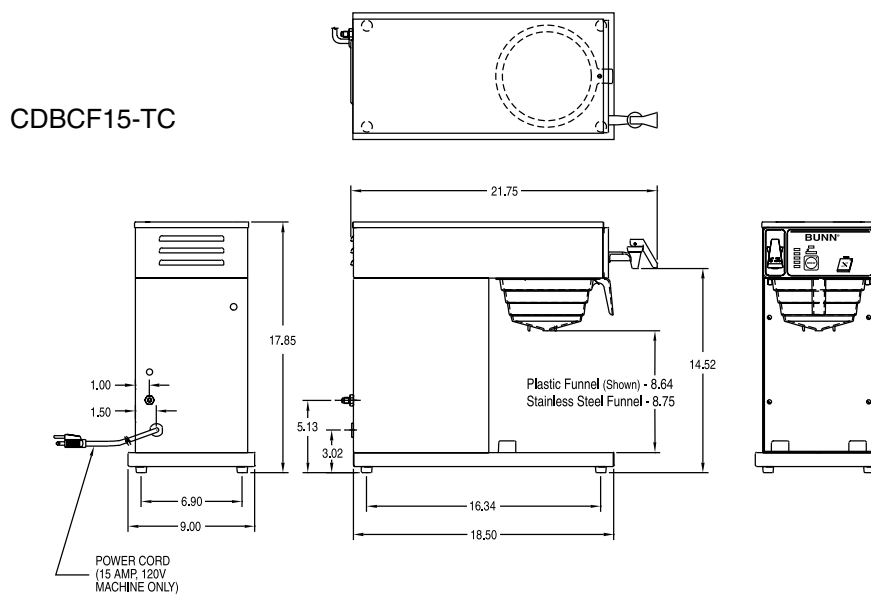
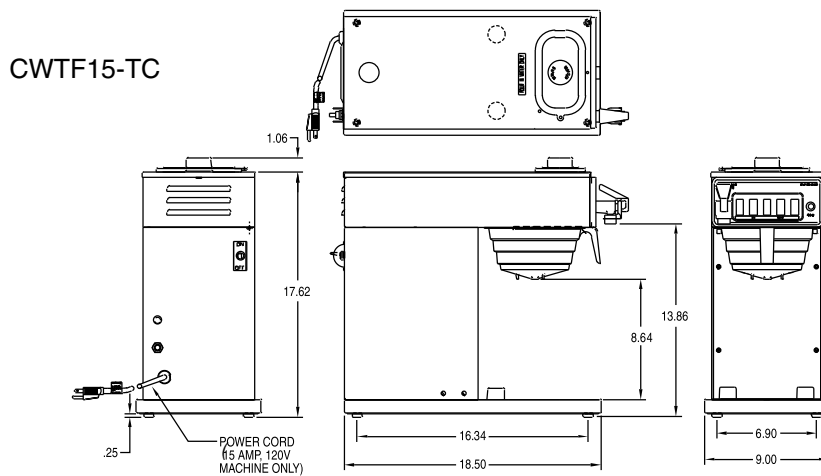

Bunn-O-Matic Corporation of Canada - 280 Industrial Pkwy. S. Aurora, Ontario L4G 3T9 • 905-841-2866 • Fax 905-841-2775 • www.bunn.com

BUNN® practices continuous product research and improvement. We reserve the right to change specifications and product design without notice. Such revisions do not entitle the buyer to corresponding changes, improvements, additions or replacements for previously purchased equipment.

All dimensions shown in inches. Bunn Corporation owns all copyrights relating to materials in this publication. Please contact Bunn Corporation to request permission to reproduce any portion of this publication.