

BUNN J®

4
=

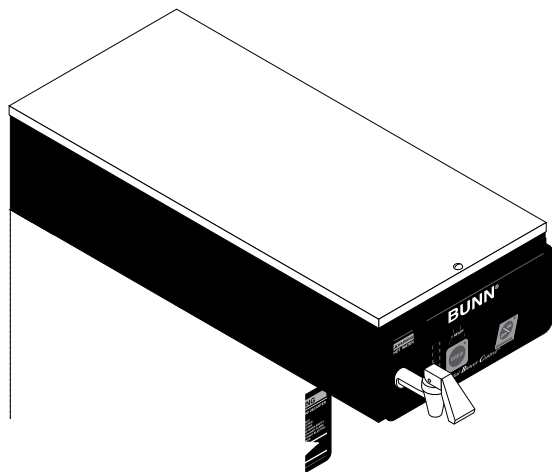

MANUAL

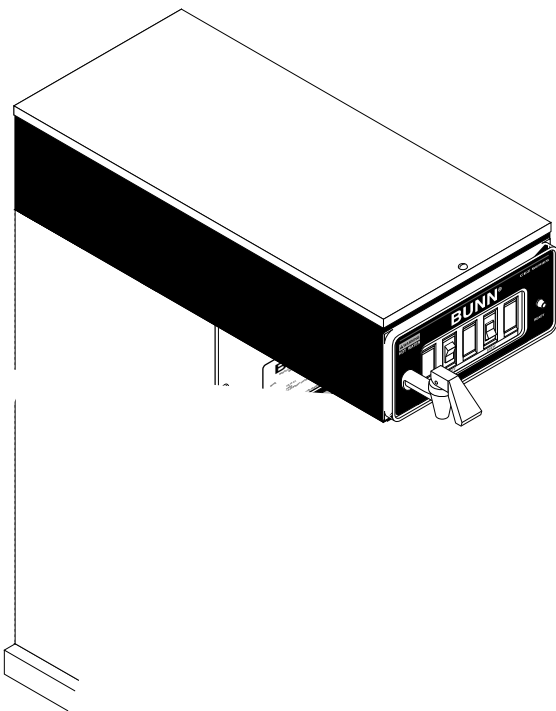

INTRODUCTION

This equipment will automatically brew a half-gallon batch of coffee into an awaiting server at the press of a button. A hot water faucet may be included for allied beverage use. Most functions of the brewer are digitally controlled. It is only for indoor use on a sturdy counter or shelf.

CONTENTS

| | |
|---|----|
| Introduction & Warranty | 2 |
| User Notices | 3 |
| Electrical & Plumbing Requirements | 4 |
| Operating Controls..... | 5 |
| Initial Set-Up, Coffee Brewing, & Cleaning..... | 6 |
| CEZ-APS/TS/TSR Adjustments & Optional Settings | 7 |
| CDBC-APS/TS/TSR Adjustments & Optional Settings | 8 |
| Troubleshooting | 9 |
| Service..... | 20 |
| Wiring Diagrams..... | 31 |

WARRANTY

Bunn-O-Matic Corp. (“Bunn”) warrants the equipment manufactured by it to be commercially free from defects in material and workmanship existing at the time of manufacture and appearing within one year from the date of installation. In addition:

1.) Bunn warrants electronic circuit and/or control boards to be commercially free from defects in material and workmanship for two years from the date of installation.

2.) Bunn warrants the compressor on refrigeration equipment to be commercially free from defects in material and workmanship for two years from the date of installation.

3.) Bunn warrants that the grinding burrs on coffee grinding equipment will grind coffee to meet original factory screen sieve analysis for three years from date of installation or for 30,000 pounds of coffee, whichever comes first.

This warranty does not apply to any equipment, component or part that was not manufactured by Bunn or that, in Bunn’s judgement, has been affected by misuse, neglect, alteration, improper installation or operation, improper maintenance or repair, damage or casualty.

THE FOREGOING WARRANTY IS EXCLUSIVE AND IS IN LIEU OF ANY OTHER WARRANTY, WRITTEN OR ORAL, EXPRESS OR IMPLIED, INCLUDING, BUT NOT LIMITED TO, ANY IMPLIED WARRANTY OF EITHER MERCHANTABILITY OR FITNESS FOR A PARTICULAR PURPOSE. The agents, dealers or employees of Bunn are not authorized to make modifications to this warranty or to make additional warranties that are binding on Bunn. Accordingly, statements by such individuals, whether oral or written, do not constitute warranties and should not be relied upon.

The Buyer shall give Bunn prompt notice of any claim to be made under this warranty by telephone at (217) 529-6601 or by writing to Post Office Box 3227, Springfield, Illinois, 62708-3227. If requested by Bunn, the Buyer shall ship the defective equipment prepaid to an authorized Bunn service location. If Bunn determines, in its sole discretion, that the equipment does not conform to the warranty, Bunn shall repair the equipment with no charge for parts during the warranty period and no charge for labor by a Bunn Authorized Service Representative during the warranty period. If Bunn determines that repair is not feasible, Bunn shall, at its sole option, replace the equipment or refund the purchase price for the equipment.

THE BUYER’S REMEDY AGAINST BUNN FOR THE BREACH OF ANY OBLIGATION ARISING OUT OF THE SALE OF THIS EQUIPMENT, WHETHER DERIVED FROM WARRANTY OR OTHERWISE, SHALL BE LIMITED, AS SPECIFIED HEREIN, TO REPAIR OR, AT BUNN’S SOLE OPTION, REPLACEMENT OR REFUND.

In no event shall Bunn be liable for any other damage or loss, including, but not limited to, lost profits, lost sales, loss of use of equipment, claims of Buyer’s customers, cost of capital, cost of down time, cost of substitute equipment, facilities or services, or any other special, incidental or consequential damages.

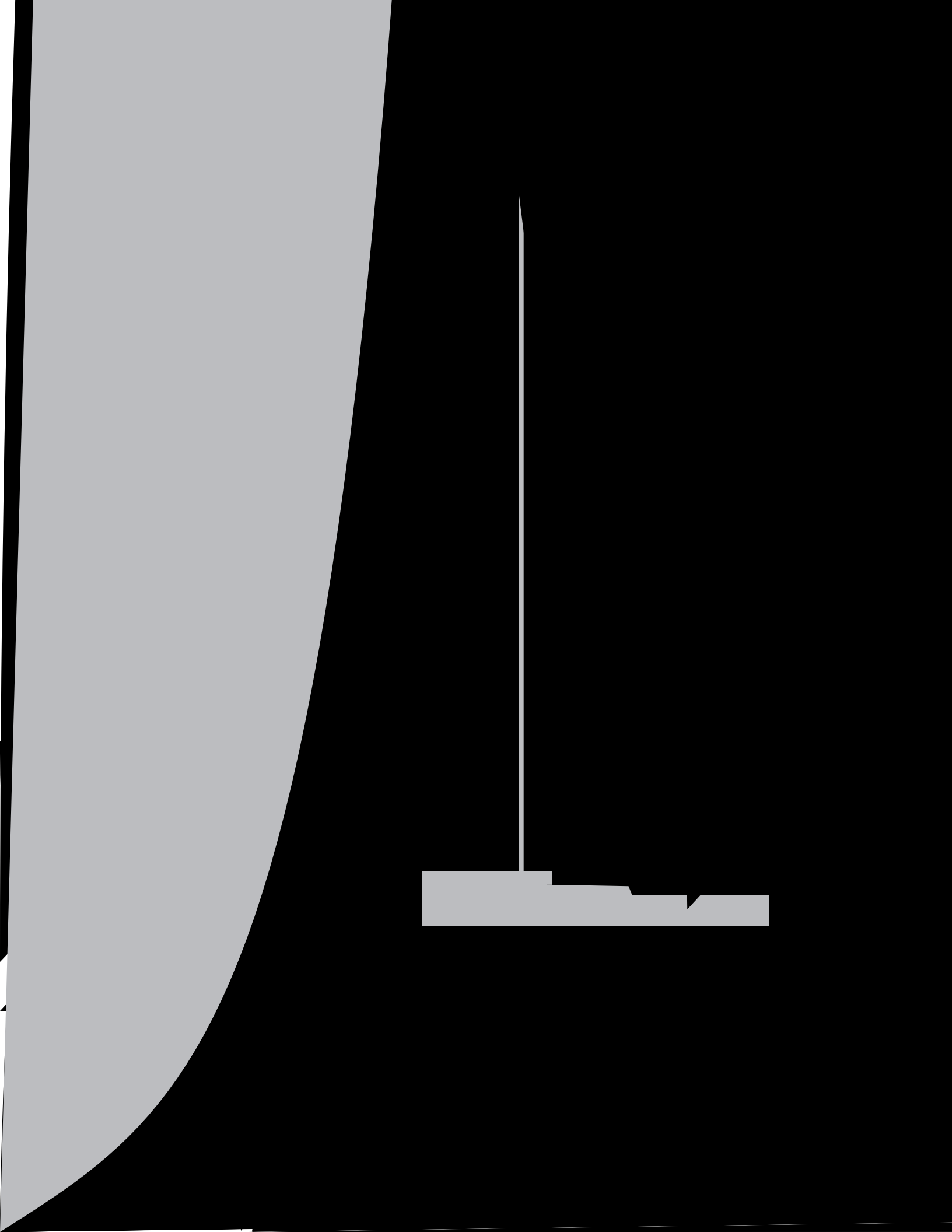

ELECTRICAL REQUIREMENTS

CAUTION - The brewer must be disconnected from the power source until specified in *Initial Set-Up*.

Model 15 has an attached cordset and requires 2-wire grounded service rated 120 volts ac, 15 amp, single phase, 60 Hz.

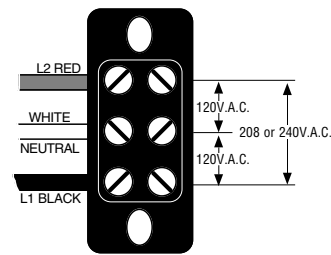
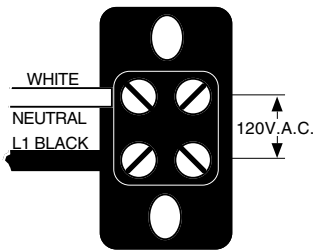

Model 20 requires 2-wire, grounded service rated 120 volts ac, 20 amp, single phase, 60 Hz. Proceed as follows:

Model 35 requires 3-wire, grounded service rated 120/208 or 120/240 volts ac, 20 amp, single phase, 60 Hz. Proceed as follows:

Electrical Hook-Up

CAUTION – Improper electrical installation will damage electronic components.

1. An electrician must provide electrical service as specified.
2. Using a voltmeter, check the voltage and color coding of each conductor at the electrical source.
3. Remove the front panel beneath the sprayhead.
4. Feed the cord through the strain relief and connect it to the terminal block.
5. Connect the brewer to the power source and verify the voltage at the terminal block before proceeding. Replace the front panel.
6. If plumbing is to be hooked up later be sure the brewer is disconnected from the power source. If plumbing has been hooked up, the brewer is ready for Initial Set-Up.

PLUMBING REQUIREMENTS

These brewers must be connected to a cold water system with operating pressure between 20 and 90 psi (138 and 620 kPa) from a ½" or larger supply line. A shut-off valve should be installed in the line before the brewer. Install a regulator in the line when pressure is greater than 90 psi (620 kPa) to reduce it to 50 psi (345 kPa). The water inlet fitting is ¼" flare. Bunn-O-Matic does not recommend the use of a reverse-osmosis or deionized water supply to this equipment.

NOTE - Bunn-O-Matic recommends ¼" copper tubing for installations of less than 25 feet and ⅜" for more than 25 feet from the ½" water supply line. A tight coil of copper tubing in the water line will facilitate moving the brewer to clean the countertop. Bunn-O-Matic does not recommend the use of a saddle valve to install the brewer. The size and shape of the hole made in the supply line by this type of device may restrict water flow.

This equipment must be installed to comply with the Basic Plumbing Code of the Building Officials and Code Administrators International, Inc. (BOCA) and the Food Service Sanitation Manual of the Food and Drug Administration (FDA).

Plumbing Hook-Up

1. Flush the water line.
2. Securely attach it to the flare fitting at the rear of the brewer.
3. Turn on the water supply.

OPERATING CONTROLS

Model CEZ- /TSR

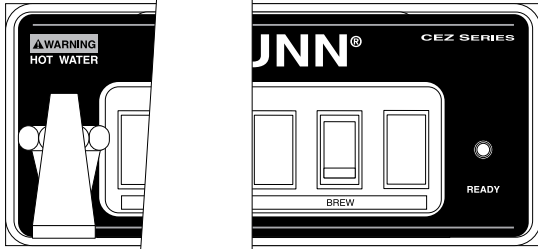

P1910

ON/OFF SWITCH

Placing the "ON/OFF" switch in the "ON" upper position enables the brew circuit, and energizes the tank refill circuit. Placing the switch in the "OFF" lower position stops tank refilling and brewing. Stopping a brew cycle after it has been started will not stop the flow of water into the server until the funnel is empty.

NOTE – Hot water will be available at the faucet in a limited amount when the switch is in the "OFF" position because the tank will not refill.

BREW SWITCH

Momentarily pressing and releasing the switch starts a brew cycle when the "ON/OFF" switch is in the "ON" upper position.

NOTE – The "ON/OFF" switch must be in the "ON" upper position to initiate and complete a brew cycle.

READY INDICATOR

This indicator glows when the preselected brew water temperature has been achieved.

Model CEZ- /TSR

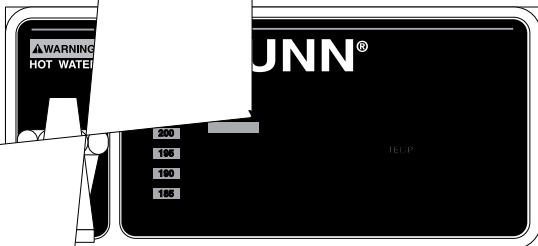

P1911

ON/OFF SWITCH

Pressing the "ON/OFF" switch (indicator glowing) enables the brew circuit and energizes the tank refill circuit. Pressing the switch again (indicator not glowing) stops tank refilling and brewing. Stopping a brew cycle after it has been started will not stop the flow of water into the server until the funnel is empty.

NOTE – Hot water will be available at the faucet in a limited amount when the "ON/OFF" indicator is not glowing because the tank will not refill.

BREW SWITCH

Momentarily pressing and releasing the switch starts a brew cycle when the "ON/OFF" indicator is glowing.

NOTE – The "ON/OFF" indicator must be glowing to initiate and complete a brew cycle.

READY INDICATOR

This indicator glows when the preset temperature has been achieved. The word "NOT" above "READY" will glow in all other instances.

TEMPERATURE INDICATORS (Feature disabled from the factory – refer to page 8.)

The indicator glows to communicate the brew water temperature. Two indicators will glow when the temperature is between them.

INITIAL SET-UP

1. Insert an empty funnel into the funnel rails.
2. Place an empty server under the funnel.
3. Connect the brewer to the power source.
4. Model CDBC-APS/TS/TSR – Press the "ON/OFF" switch (indicator glowing).
Model CEZ-APS/TS/TSR – Place the "ON/OFF" switch in the "ON" upper position.
5. Water will flow into the tank and stop when the tank is filled to its capacity.
6. Wait approximately twenty minutes for the water in the tank to heat to the proper temperature.
7. Place a small vessel beneath the faucet and open the faucet handle. Release it when you hear the tank refilling.
8. Model CDBC-APS/TS/TSR – Press the "ON/OFF" switch (indicator glowing) then momentarily press and release the "BREW" switch.
Model CEZ-APS/TS/TSR – Place the "ON/OFF" switch in the "ON" upper position then momentarily press and release the "BREW" switch.
9. Allow the cycle to finish and measure the amount of water in the server. It should be 64 ounces \pm 2. Refer to the adjustments section of this manual should the volume need to be increased or decreased.

The brewer is now ready for use in accordance with the coffee brewing instructions below.

COFFEE BREWING

1. Insert a BUNN® filter into the funnel.
2. Pour the fresh coffee into the filter and level the bed of grounds by gently shaking.
3. Slide the funnel into the funnel rails.
4. Place an empty server beneath the funnel.
5. Model CDBC-APS/TS/TSR – Press the "ON/OFF" switch (indicator glowing) then momentarily press and release the "BREW" switch.
Model CEZ-APS/TS/TSR – Place the "ON/OFF" switch in the "ON" upper position then momentarily press and release the "BREW" switch.
6. When brewing is completed, simply discard the grounds and filter.

CLEANING

1. The use of a damp cloth rinsed in any mild, non-abrasive, liquid detergent is recommended for cleaning all surfaces on Bunn-O-Matic equipment.
2. Check and clean the sprayhead. The sprayhead holes must always remain open.

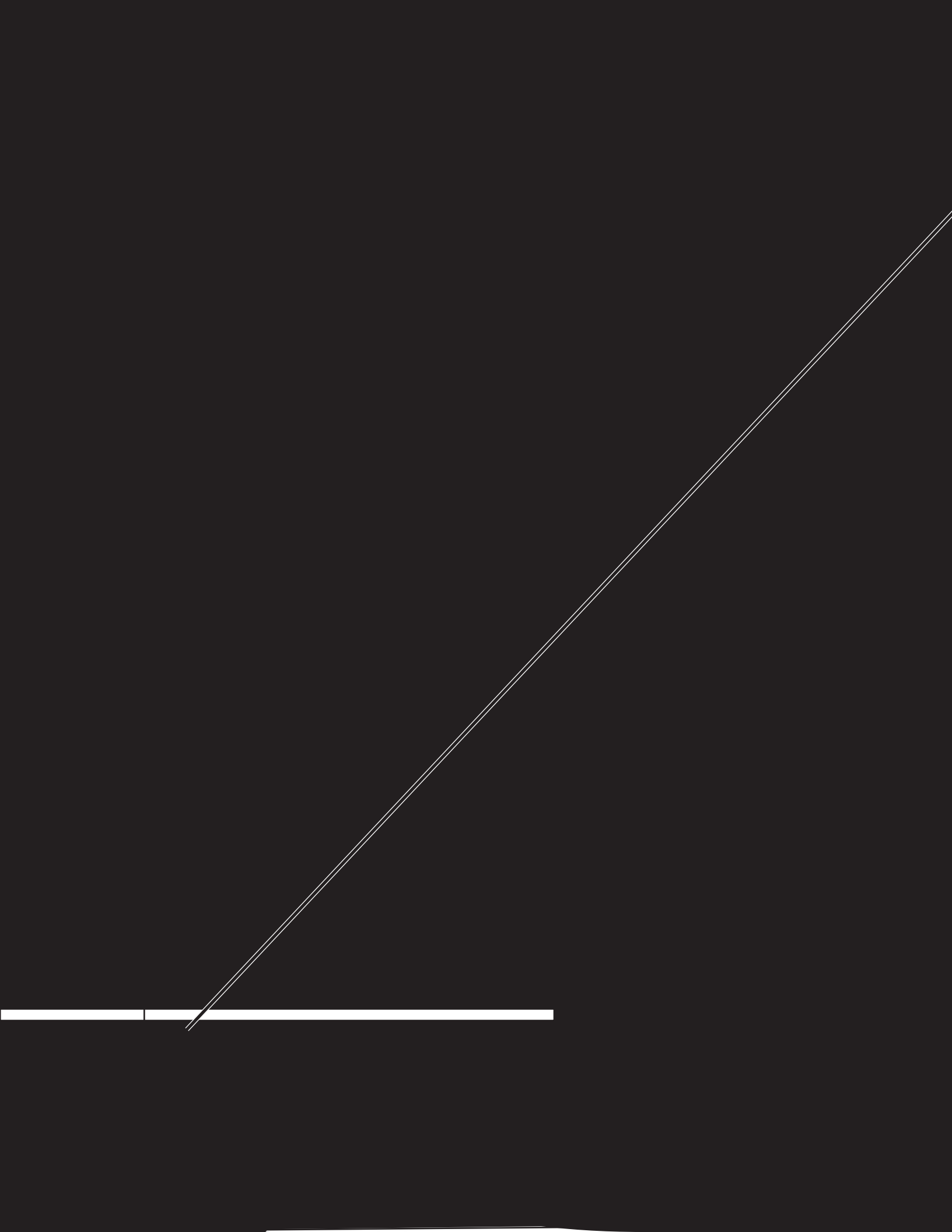

CDBC-APS/TS/TSR ADJUSTMENTS & OPTIONAL SETTINGS

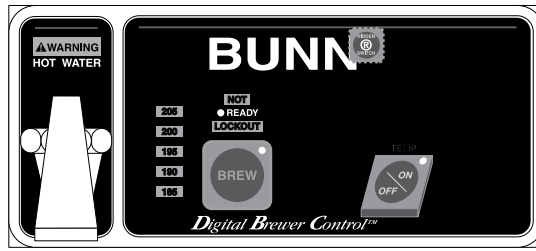

P1912

Setting Brew Temperature

The brewer is factory set to brew at 200°F(95°C). To change this setting, press and hold the "HIDDEN" switch beneath the "®". The word "TEMP" above the "ON/OFF" switch will glow to correspond with the temporary function change of this switch. Repeatedly press and release the "ON/OFF" switch until one of the bank of temperature indicators shows the approximate desired temperature. When two indicators are glowing, the temperature is approximately the number between them.

Displaying Brew Temperature

The brewer is factory set with the temperature display disabled. To change this setting, press and hold the "ON/OFF" switch and the "HIDDEN" switch beneath the "®" for five seconds, the entire bank of temperature indicators will glow. Release both switches. Pressing and releasing the "ON/OFF" switch will toggle between turning the entire bank of temperature indicators on-or-off, signifying the "ON" or "OFF" condition of this display. Wait for a few seconds, the brewer will maintain this last setting.

Setting Brew Lockout

The brewer is factory set with the brew lockout disabled. Brew lockout prevents starting a brew cycle if the ready indicator is not glowing. When an attempt at brewing cannot be allowed, the word "NOT" and "LOCKOUT" flash for three seconds to indicate the reason the brew can't begin. To change the condition of the brew lockout, press and hold the "HIDDEN" switch beneath the "®" and momentarily press the "BREW" switch.

IMPORTANT: The tank must be full and fill solenoid shut off prior to making these adjustments.

Adjusting Brew Volumes

The brewer is factory set to deliver 64 ounces \pm 2 for each brew cycle.

BREW VOLUME SET-UP: Use the following steps when the setting is unknown or a different circuit board is being installed.

1. Place an empty funnel in the funnel rails and an empty server or graduated vessel beneath the funnel.
2. Place the "ON/OFF" switch in the "ON", upper position.
3. Press and hold the brew start button until you hear the brew solenoid click on-and-off three times (approximately 5 seconds). Release the button.
4. Allow the cycle to continue until the desired amount of water is dispensed and then turn "OFF" the brewer. The brewer is now set to dispense this amount of water for each subsequent brew cycle.

To **increase** the amount of water for each brew cycle place an empty funnel in the funnel rails and an empty server or graduated vessel beneath the funnel. Press the "ON/OFF" switch. Press and hold the "BREW" switch until you hear the solenoid click on-and-off three times (approximately 5 seconds), then release the "BREW" switch. Momentarily press and release the "BREW" switch once for each ounce (approximate) of water to be added to the prior setting and allow the brew cycle to finish.

To **decrease** the amount of water for each brew cycle place an empty funnel in the funnel rails and an empty server or graduated vessel beneath the funnel. Press the "ON/OFF" switch. Momentarily press and release the "BREW" switch once for each ounce (approximate) of water to be removed from the existing setting. Press and hold the "BREW" switch until you hear the solenoid click on-and-off three times (approximately 5 seconds), then release the "BREW" switch and allow the cycle to finish.

TROUBLESHOOTING

A troubleshooting guide is provided to suggest probable causes and remedies for the most likely problems encountered. If the problem remains after exhausting the troubleshooting steps, contact the Bunn-O-Matic Technical Service Department.

- Inspection, testing, and repair of electrical equipment should be performed only by qualified service personnel.
- All electronic components have 120 volt ac and low voltage dc potential on their terminals. Shorting of terminals or the application of external voltages may result in board failure.
- Intermittent operation of electronic circuit boards is unlikely. Board failure will normally be permanent. If an intermittent condition is encountered, the cause will likely be a switch contact or a loose connection at a terminal or crimp.
- Solenoid removal requires interrupting the water supply to the valve. Damage may result if solenoids are energized for more than ten minutes without a supply of water.
- The use of two wrenches is recommended whenever plumbing fittings are tightened or loosened. This will help to avoid twists and kinks in the tubing.
- Make certain that all plumbing connections are sealed and electrical connections tight and isolated.
- This brewer is heated at all times. Keep away from combustibles.

- WARNING** –
- Exercise extreme caution when servicing electrical equipment.
 - Unplug the brewer when servicing, except when electrical tests are specified.
 - Follow recommended service procedures.
 - Replace all protective shields or safety notices.

Before troubleshooting this brewer, check for the following:

- A. Control Boards (CDBC-APS/TS/TSR)
1. Make sure ribbon cable is properly attached to the control board (ALL PINS INSERTED INTO PLUG).
 2. Make sure there is a nylon insulating washer under each screw head that holds the control board to the plastic front end cap. This is important for proper operation.
- B. Control Boards (CEZ-APS/TS/TSR)
- Locate J6 connector on control board. If jumper is across pins 1 & 2, board is set up to operate tea brewer or a brewer that DOES NOT use a water level probe. If jumper is across pins 2 & 3, board is set up to operate a coffee brewer or a brewer that uses a water level probe. Look at the bottom side of the control board. Pin 1 of connector J6 is marked by a square solder pad on the foil side of the board and pins 2,3 & 4 are marked by a round solder pad.
- C. Control Boards (CDBC-APS/TS/TSR & CEZ-APS/TS/TSR)
- Make sure before servicing brewer that voltage is present at control board.

On CDBC-APS/TS/TSR models, observe if indicator light is glowing on the control panel. If so, proceed with testing. If not, check for voltage across pins 1 & 2 of the ten pin J1 connector (black and white wires). If voltage is present, replace the control board. If voltage is not present, check wiring and voltage across terminal block (black and white). Correct the problem and retest before proceeding with testing.

On CEZ-APS/TS/TSR models, check for voltage across pins 1 & 7 of the eight pin J1 connector (black and white wires). If voltage is present, proceed with testing. If voltage is not present, check wiring and voltage across terminal block (black and white). Correct the problem and retest before proceeding with testing.

TROUBLESHOOTING (cont.)

REFILL CIRCUIT

PROBLEM

Will not fill or refill

PROBABLE CAUSE

1. Power off to brewer (CDBC-APS/TS/TSR & CEZ-APS/TS/TSR)
2. Water shut off (CDBC-APS/TS/TSR & CEZ-APS/TS/TSR)
3. Display flashing (CDBC-APS/TS/TSR) or ready light flashing (CEZ-APS/TS/TSR)
4. ON/OFF Switch (CDBC-APS/TS/TSR & CEZ-APS/TS/TSR)
5. Lime build up on Probe (CDBC-APS/TS/TSR & CEZ-APS/TS/TSR)
6. Refill Valve or Control Board (CDBC-APS/TS/TSR & CEZ-APS/TS/TSR)

REMEDY

Press ON/OFF switch on control panel to determine if power is ON.

Make sure water is ON.

Brewer has shut down due to malfunction (See Diagnostic Chart in manual, Page 19, or under top lid of brewer).

Make sure ON/OFF Switch is "ON" and indicator is lit.

Remove the Probe and check for lime deposit on tip. Clean and reinstall.

Disconnect the brewer from the power source and remove wires from refill valve coil. Check for continuity across the terminals of the solenoid coil. If continuity is not present, replace the refill valve (See page 30). If continuity is present, the valve may be stuck closed. Shut water off to brewer. Set the ON/OFF switch to the "OFF" position. Open the faucet and drain water down in the tank until flow stops or slows to a trickle. Attach a voltmeter to the terminals of the refill solenoid. Connect the brewer to the power source. Press the switch "ON". Within five seconds, voltage should be present at the solenoid terminals. If voltage is not present, refer to the wiring diagrams and check the wiring harness.

TROUBLESHOOTING (cont.)

REFILL CIRCUIT (cont.)

PROBLEM

Fill or refill does not shut "OFF"
(ON/OFF Switch "ON")

PROBABLE CAUSE

1. Lime build up on probe (CDBC-APS/TS/TSR & CEZ-APS/TS/TSR)

2a. Water Level Probe Sensing System (CDBC-APS/TS/TSR)

2b. Water Level Probe Sensing System (CEZ-APS/TS/TSR)

3. Refill valve or control board (CDBC-APS/TS/TSR & CEZ-APS/TS/TSR)

Fill or refill does not shut "OFF"
(ON/OFF Switch "OFF")

1. Refill valve or control board (CDBC-APS/TS/TSR & CEZ-APS/TS/TSR)

REMEDY

Remove Probe and check for lime deposits on tip. Clean and reinstall.

A) Disconnect the brewer from the power source. Disconnect the J3 connector from the control board. Check for continuity from the nut on top of the level probe to pin 1 of the plug, continuity should be present. Pull the temperature probe up about an inch from the grommet. Check for continuity from the outside surface of the temperature probe and pin 4 of the plug, continuity should be present. Connect the J3 plug to the control board and proceed to step 3.

B) Disconnect the brewer from the power source. Disconnect the J5 connector from the control board. Check for continuity from the nut on top of the level probe to pin 5 of the plug, continuity should be present. Pull the temperature probe up about an inch from the grommet. Check for continuity from the outside surface of the temperature probe and pin 2 of the plug, continuity should be present. Connect the J5 plug to the control board and proceed to step 3.

Press ON/OFF switch to "ON" (Indicator lamp should be lit). If water continuously flows out of air vent tube, disconnect the brewer from the power source. If water flow stops, replace the control board. If water flow does not stop, repair or replace the refill solenoid. (See page 30)

If water continuously flows out of air vent tube, disconnect the brewer from the power source. If water flow does not stop, repair or replace the refill solenoid. If the valve closes when power is removed, replace the control board. (See pages 21 & 22)

TROUBLESHOOTING (cont.)

HEATING CIRCUIT

PROBLEM

Water does not heat to proper temperature

IMPORTANT: Make sure no temperature tests are taken before the ready light is "ON". Tank temperature must be stabilized before readings are taken.

PROBABLE CAUSE

1. Display flashing (CDBC-APS/TS/TSR) or ready light flashing (CEZ-APS/TS/TSR)

2. Water not touching temperature probe

3a. Dry Plug In Probe Sensing System (CDBC-APS/TS/TSR)

3b. Dry Plug In Probe Sensing System (CEZ-APS/TS/TSR)

REMEDY

Brewer has shut down due to malfunction (See Diagnostic Chart in manual, Page 19, or under top lid).

Remove probe and grommet. Look into hole on tank lid. Water must be within one inch from top of tank.

A) Disconnect the brewer from the power source. Disconnect the J3 connector from the control board. Check for continuity from the tank mounting screw where the green wire mounts, to pin 2 of the plug, continuity should be present. Pull the temperature probe up about an inch from the grommet. Check for continuity from the outside surface of the temperature probe and pin 4 of the plug, continuity should be present. Connect the J3 plug to the control board and proceed to step 4a.

B) Disconnect the brewer from the power source. Disconnect the J5 connector from the control board. Check for continuity from the tank mounting screw where the green wire mounts, to pin 4 of the plug, continuity should be present. Pull the temperature probe up about an inch from the grommet. Check for continuity from the outside surface of the temperature probe and pin 2 of the plug, continuity should be present. Connect the J5 plug to the control board and proceed to step 4b.

TROUBLESHOOTING (cont.)

HEATING CIRCUIT (cont.)

PROBLEM

Water does not heat to proper temperature (cont.)

IMPORTANT: Make sure no temperature tests are taken before the ready light is "ON". Tank temperature must be stabilized before readings are taken.

PROBABLE CAUSE

4a. Temperature Probe (CDBC-APS/TS/TSR)

4b. Temperature Probe (CEZ-APS/TS/TSR)

5. Limit Thermostat (CDBC-APS/TS/TSR & CEZ-APS/TS/TSR)

6. Tank Heater (CDBC-APS/TS/TSR & CEZ-APS/TS/TSR)

Spitting or excessive steaming

1. Lime build up on temperature probe, tank or tank heater

REMEDY

A) Remove the probe from the grommet and submerge in a water bath of approximately 70°F(21°C). Connect an ohmmeter to pins 3 and 4 of the J3 connector. At 60°F(16°C) the reading should be 15.3k ± 2k OHMS, at 70°F(21°C) the reading should be 11.8k ± 2k OHMS, and at 80°F(27°C) the reading should be 9.3k ± 2k OHMS. If the probe is within these parameters, reconnect the J3 plug to the control board.

B) Remove the probe from the grommet and submerge in a water bath of approximately 70°F(21°C). Connect an ohmmeter to pins 2 and 3 of the J5 connector. At 60°F(16°C) the reading should be 15.3k ± 2k OHMS, at 70°F(21°C) the reading should be 11.8k ± 2k OHMS, and at 80°F(27°C) the reading should be 9.3k ± 2k OHMS. If the probe is within these parameters, reconnect the J5 plug to the control board.

Disconnect the brewer from the power source. Check for continuity across the limit thermostat terminals. Continuity should be present. If not replace the limit thermostat.(See page 27)

Disconnect the brewer from the power source. Check for continuity between the white terminal of the terminal block and the black wire on the relay on the control board. There should be a low OHM reading. If no continuity is present, check for a wiring problem, then replace the tank heater if no wiring problem is found.(See page 28)

Inspect probe and tank assembly for excessive lime deposits. Delime as required.

TROUBLESHOOTING (cont.)

HEATING CIRCUIT (cont.)

PROBLEM

Spitting or excessive steaming (cont.)

PROBABLE CAUSE

2a. Temperature Probe (CDBC-APS/TS/TSR)

2b. Temperature Probe (CEZ-APS/TS/TSR)

3. Control Board (CDBC & CEZ)

Brewer is making unusual noises

1. Plumbing lines

2. Water supply

3. Lime build up

REMEDY

A) Remove the probe from the grommet and submerge in a water bath of approximately 70°F(21°C). Connect an ohmmeter to pins 3 and 4 of the J3 connector. At 60°F(16°C) the reading should be 15.3k ± 2k OHMS, at 70°F(21°C) the reading should be 11.8k ± 2k OHMS, and at 80°F(27°C) the reading should be 9.3k ± 2k OHMS. If the probe is within these parameters, reconnect the J3 plug to the control board.

B) Remove the probe from the grommet and submerge in a water bath of approximately 70°F(21°C). Connect an ohmmeter to pins 2 and 3 of the J5 connector. At 60°F(16°C) the reading should be 15.3k ± 2k OHMS, at 70°F(21°C) the reading should be 11.8k ± 2k OHMS, and at 80°F(27°C) the reading should be 9.3k ± 2k OHMS. If the probe is within these parameters, reconnect the J5 plug to the control board.

Set the temperature to 200°F (95°C). Let tank temperature stabilize. If temperature in tank is above temperature setting by more than 7°F, replace the control board.(See pages 21 & 22)

Plumbing lines should not rest on the counter top.

The brewer must be connected to a cold water supply.

Remove the tank lid and clean inside of tank with a deliming agent, if necessary.

TROUBLESHOOTING (cont.)

BREWING CIRCUIT

PROBLEM

Brew cycle will not start

PROBABLE CAUSE

1. Display flashing (CDBC-APS/TS/TSR) or ready light flashing (CEZ-APS/TS/TSR)
2. No water
3. No power or incorrect voltage to the brewer
4. ON/OFF switch not in the "ON" position
5. Low water temperature (Brew lockout is enabled)
6. Water not touching refill probe inside tank
7. Switch panel (CDBC-APS/TS/TSR)

REMEDY

Brewer has shut down due to malfunction (See Diagnostic Chart in manual, Page 19, or under top lid of brewer).

Water lines and valves to the brewer must be open.

Check for voltage across the black and white terminals at the terminal block.

The indicator lamp must be lit

Allow brewer to heat until ready lamp is lit, or disable the brew lockout feature. (See page 7 or 8)

Press ON/OFF switch (indicator must be lit). Brewer will refill until water touches probe inside tank. Water must be in contact with refill probe before brew cycle will start.

Disconnect the brewer from the power source. Disconnect the ribbon connector from the control board. Check for continuity between pins 1 & 2 (An arrow on the connector indicates pin 1). No continuity should be present. Press the BREW switch. Continuity should be present for as long as the switch is held "ON". If no continuity is present, replace the switch membrane decal. (See page 23)

TROUBLESHOOTING (cont.)

BREWING CIRCUIT (cont.)

PROBLEM

Brew cycle will not start (cont.)

PROBABLE CAUSE

8. Control board or dispense valve (CDBC-APS/TS/TSR & CEZ-APS/TS/TSR)

REMEDY

If the start switch (CEZ-APS/TS/TSR) or switch panel (CDBC-APS/TS/TSR) is operating properly, proceed as follows. Attach a voltmeter to the terminals of the dispense valve solenoid. Connect the brewer to the power source. Turn on the brewer and press the BREW switch. Voltage should be present at the solenoid terminals. If voltage is not present, refer to the wiring diagrams and check the wiring harness. If voltage is present, check for continuity across the terminals of the solenoid coil. If continuity is not present, replace the solenoid valve (See page 26). If continuity is present, the valve may be stuck closed.

Consistently low beverage level in the dispenser or beverage overflows dispenser

1. Brew volume (CDBC-APS/TS/TSR & CEZ-APS/TS/TSR)

NOTE: All volumes to run with sprayhead attached.

Set up brewer according to instructions in section **Adjustments-Brew Volumes**. (See pages 7 or 8) Using a stop watch or second hand, time the length of the brew cycle. Record this time inside the top lid. If service is ever needed again, use the time as reference to determine if time has changed.

2. Lime build up

Inspect the dispense valve and sprayhead for excessive lime deposits. Delime as required.

3. Dispense Valve

Remove dispense valve and clear any obstructions. Rebuild or replace valve if necessary. (See page 26)

TROUBLESHOOTING (cont.)

BREWING CIRCUIT (cont.)

| PROBLEM | PROBABLE CAUSE | REMEDY |
|-------------------------|-----------------------|--|
| Dripping from sprayhead | 1. Lime build up | Inspect the tank assembly for excessive lime deposits. Delime as required. |
| | 2. Dispense valve | Remove the dispense valve and clear any obstructions. Rebuild or replace the valve if necessary. (See page 26) |
| Weak beverage | 1. Sprayhead | A six-hole stainless steel sprayhead must be used for proper extraction. |
| | 2. Water temperature | Place an empty brew funnel on an empty server beneath the sprayhead. Initiate brew cycle and check the water temperature immediately below the sprayhead with a thermometer. The reading must not be less than 195°F(91°C). Adjust the temperature setting to increase the water temperature. Refer to <i>Initial Set-up</i> instructions. |
| | 3. Filter type | BUNN® paper filters must be used for proper extraction. |
| | 4. Coffee grind | A fine drip or grind must be used for proper extraction. |
| | 5. Funnel loading | The BUNN® paper filter must be centered in the funnel and the bed of grounds leveled by shaking gently. |

TROUBLESHOOTING (cont.)

BREWING CIRCUIT (cont.)

PROBLEM

Dry coffee grounds remain in the funnel

PROBABLE CAUSE

1. Sprayhead

2. Funnel loading

REMEDY

Make sure sprayhead is present and holes are clear and unobstructed. There should be six separate streams of water coming out of the sprayhead.

The BUNN® paper filter must be centered in the funnel and the bed of grounds leveled by shaking gently.

DIAGNOSTICS

Intermittent flashing of the READY indicator (Model CEZ) or the bank of temperature indicators (Model CDBC) indicates that a fault exists. Count the number of flashes between pauses and use this chart as a guide to investigating the fault.

| FLASHES | CAUSE | THINGS TO CHECK |
|---------|--|--|
| 1 | Dry Plug - In Fault - Sheath of temperature probe dry for 10 minutes after power-up | Water Pressure Temperature probe wiring Fill valve wiring, function, & strainer Green wire between tank and circuit board |
| 2 | Low Tank Level Fault - Level probe dry for 7 minutes after fill valve is energized | Water pressure Level probe wiring Temperature probe wiring Fill valve wiring, function, & strainer |
| 3 | Low Water Temperature Fault - Sensor in tank is calling for heat for 30 minutes or more | Tank heater wiring & function Temperature probe wiring |
| 4 | Tank Sensor Disagreement - Level probe detects water, but dry plug-in probe dry | Temperature probe wiring Level probe wiring Green wire between tank and circuit board |
| 5 | Temp Sensor Out-of-Range - High | Sensor not connected to circuit board |
| 6 | Temp Sensor Out-of-Range - Low | Sensor wires shorted together or to chassis |

SERVICE

This section provides procedures for testing and replacing various major components used in this brewer should service become necessary. Refer to **Troubleshooting** for assistance in determining the cause of any problem.

WARNING - Inspection, testing, and repair of electrical equipment should be performed only by qualified service personnel. The brewer should be unplugged when servicing, except when electrical tests are required and the test procedure specifically states to plug-in the brewer.

COMPONENT ACCESS

WARNING - Disconnect the brewer from the power source before the removal of any panel or the replacement of any component.

All components are accessible by the removal of the top cover or warmer housing and front access panel.

The top cover is attached with one #4-40 screw.

The front access panel is attached with four #6-32 screws.

Contents

| | |
|--|----|
| Control Board - CDBC-APS/TS/TSR | 21 |
| Control Board - CEZ-APS/TS/TSR | 22 |
| Switch Panel - CDBC-APS/TS/TSR | 23 |
| ON/OFF Switch - CEZ-APS/TS/TSR | 24 |
| BREW Switch (Start) - CEZ-APS/TS/TSR | 25 |
| Dispense Valve | 26 |
| Limit Thermostat | 27 |
| Tank Heater | 28 |
| Refill Valve | 30 |
| Wiring Diagrams | 31 |

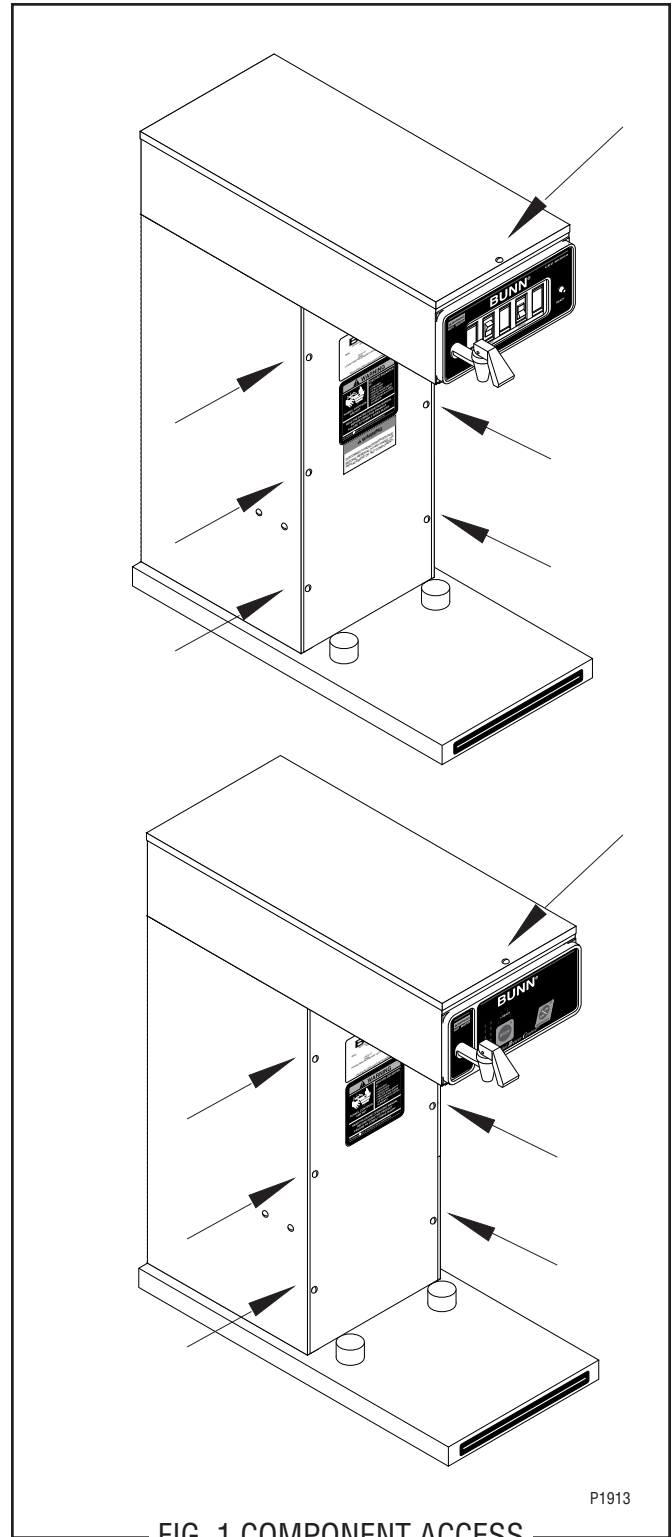

SERVICE (cont.)

CONTROL BOARD - Model CDBC-APS/TS/TSR

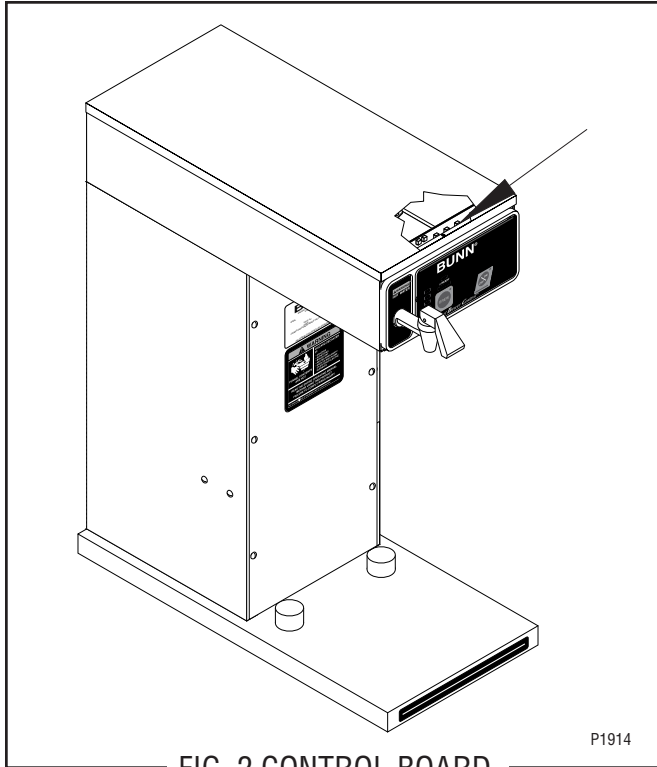

Location:

The Control Board is located inside the top cover behind the front end cap.

Test Procedures:

The test procedures for the control board will vary depending upon the problems experienced by the brewer. Refer to the Troubleshooting guide beginning on page 9. The troubleshooting guide is divided into three sections, Refill Circuit, Heating Circuit, and Brewing Circuit.

Removal and Replacement:

1. Disconnect the black wire and blue wire from the relay on the control board.
2. Disconnect the 10-pin connector and the 4-pin connector from the main wiring harness.
3. Disconnect the 11-pin connector from the control panel.
4. Remove the four #6 screws and four nylon washers and the two #4-40 screws securing the control board to the end cap assembly.
5. Install a new control board and secure with the four #6 screws and nylon washers and the two #4-40 screws to the end cap assembly.
NOTE: The four nylon washers **must** be installed under the heads of the four #6 screws to prevent a possible shorting of the control board circuits.
6. Connect the 11-pin connector from the control panel.
7. Connect the 10-pin connector and the 4-pin connector from the main wiring harness.
8. Connect the blue wire and black wire to the relay on the control board.
9. Refer to *CDBC-APS/TS/TSR Adjustments and Optional Settings* to program the new control board.

SERVICE (cont.)

CONTROL BOARD - Model CEZ-APS/TS/TSR

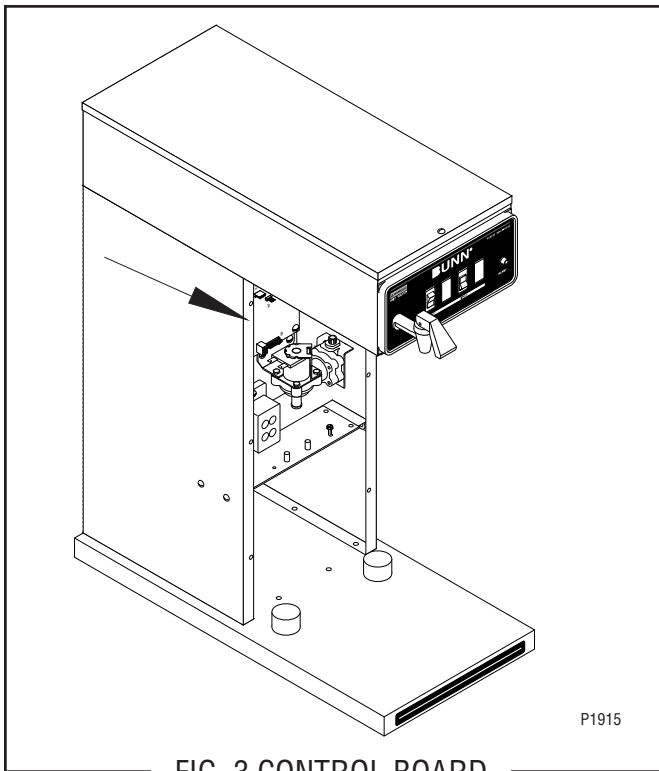

FIG. 3 CONTROL BOARD

Location:

The Control Board is located inside the trunk behind the front access panel.

Test Procedures:

The test procedures for the control board will vary depending upon the problems experienced by the brewer. Refer to the Troubleshooting guide beginning on page 9. The troubleshooting guide is divided into three sections, Refill Circuit, Heating Circuit, and Brewing Circuit.

Removal and Replacement:

1. Disconnect the black wire and blue wire from the relay on the control board.
2. Disconnect the 8-pin connector and the 6-pin connector from the main wiring harness.
3. Disconnect the 2-pin connector from the ready indicator LED.
4. Remove the four #6-32 screws securing the control board to the component mounting bracket.
5. Remove the four spacers from the control board and attach them to the new board.
6. Locate J6 connector on control board. If jumper is across pins 1 & 2, board is set to operate tea brewer or a brewer that **DOES NOT** use a water level probe. If jumper is across pins 2 & 3, board is set to operate a coffee brewer or a brewer that uses a water level probe. Look at the bottom side of the control board. Pin 1 of connector J6 is marked by a square solder pad and pins 2,3 & 4 are round.
7. Check the jumper on the brew temperature lock-out jack for desired function (enabled or disabled).
8. Check the jumper on the temperature jack for desired brew temperature. The factory setting should be 200°F(95°C)
9. Install a new control board and secure with the four #6-32 screws to the component mounting bracket.
10. Connect the 2-pin connector from the ready indicator LED.
11. Connect the 8-pin connector and the 6-pin connector from the main wiring harness.
12. Connect the blue wire and black wire to the relay on the control board.
13. Refer to *CEZ-APS/TS/TSR Adjustments and Optional Settings* to program the new control board.

SERVICE (cont.)

SWITCH PANEL - Model CDBC-APS/TS/TSR

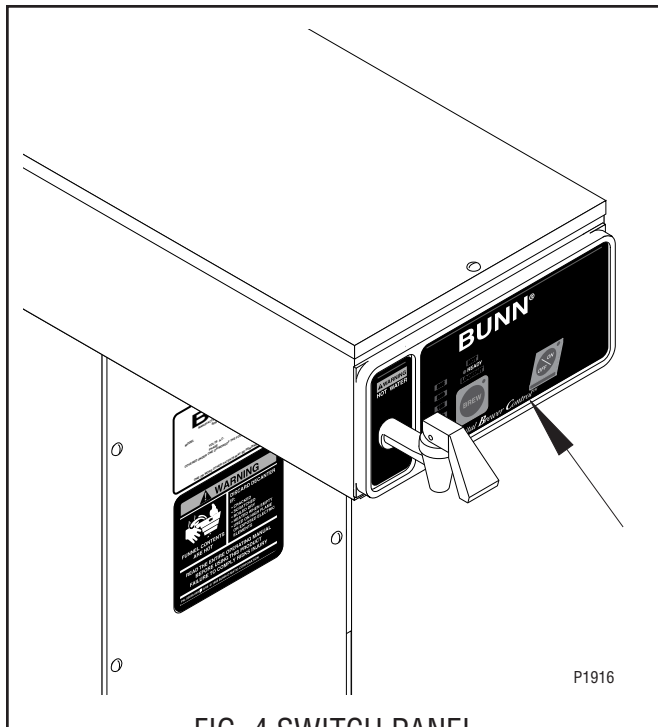

Location:

The Switch Panel is located in the front of the hood.

Test Procedures:

The test procedures for the switch panel and the control board will vary depending upon the problems experienced by the brewer. Refer to the Troubleshooting guide beginning on page 9. The troubleshooting guide is divided into three sections, Refill Circuit, Heating Circuit, and Brewing Circuit.

Removal and Replacement:

1. Disconnect the 11-pin connector to the switch panel from the control board.
2. Remove the four #6 screws, nylon washers and the two #4-40 screws securing the control board to the end cap assembly and set aside.
3. Gently pry the switch panel from the end cap assembly.
4. Remove any adhesive that remains on the end cap.
5. Remove the adhesive backing from the new switch panel. Insert the ribbon connector through the slot in the end cap and apply the switch panel to the end cap.
6. Install the control board to the back side of the end cap using the four #6 screws, nylon washers and the two #4-40 screws to the end cap assembly.
NOTE: The four nylon washers **must** be installed under the heads of the four #6 screws to prevent a possible shorting of the control board circuits.
7. Reconnect the 11-pin connector from the switch panel to the control board making sure every pin on the control board is inserted into the ribbon cable plug.

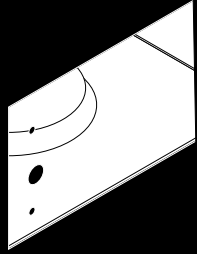
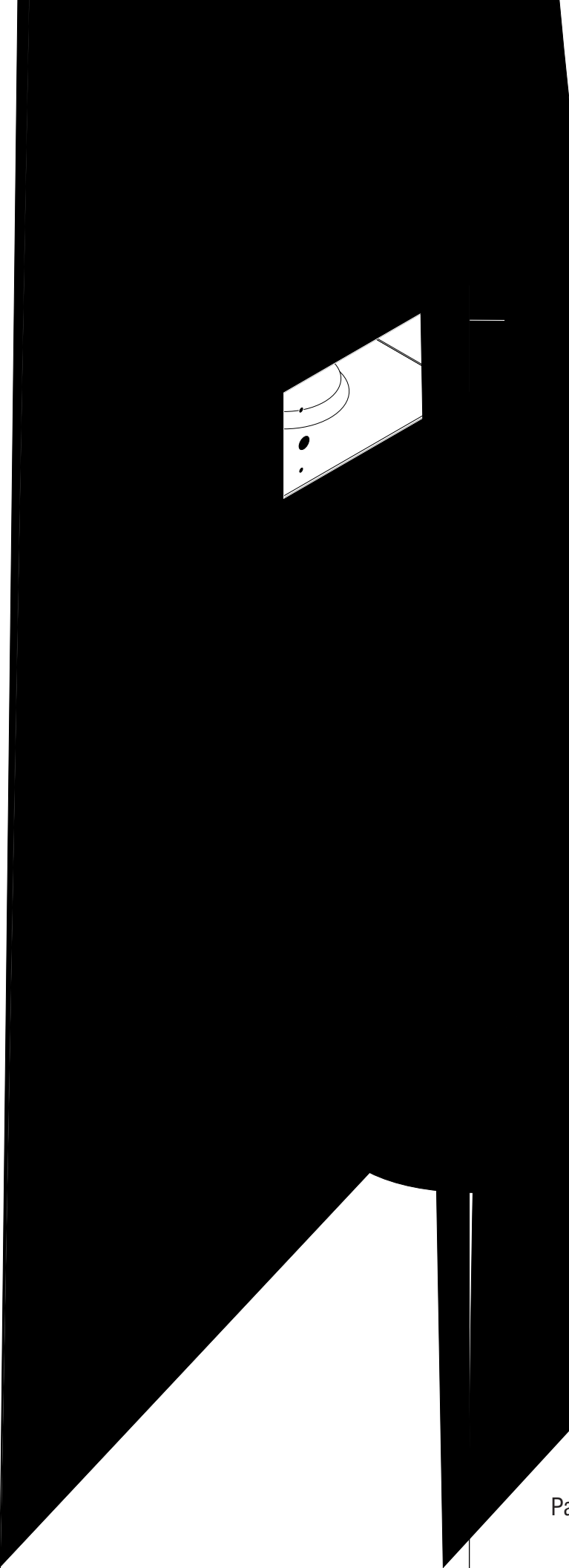

Pa

SERVICE (cont.)

BREW SWITCH (Start) - Model CEZ-APS/TS/TSR

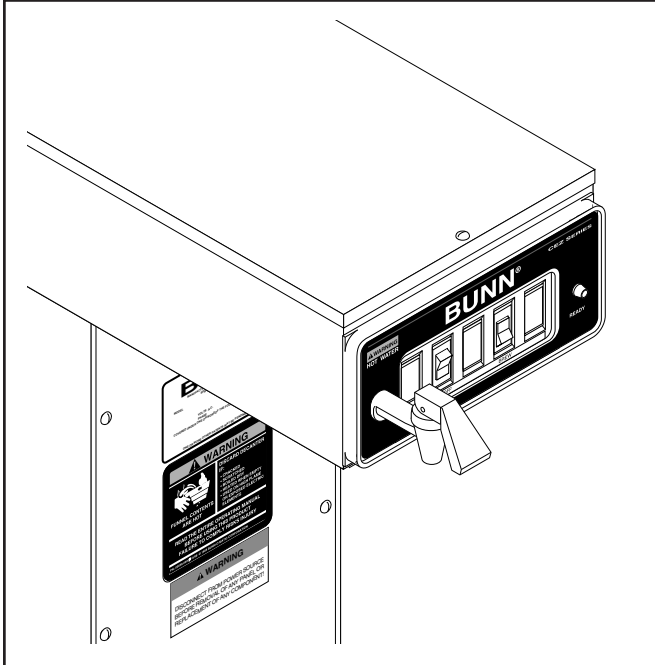

Location:

The BREW switch is located in the center front of the hood.

Test Procedure:

1. Disconnect the brewer from the power source.
2. Disconnect the white/yellow wire from the top switch terminal and the white/orange from the bottom switch terminal.
3. Check for continuity across the two terminals on the switch when it is held in the lower position. Continuity must not be present across these terminals when the switch is released.

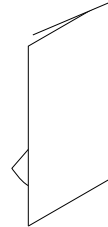

SERVICE (cont.)

DISPENSE VALVE

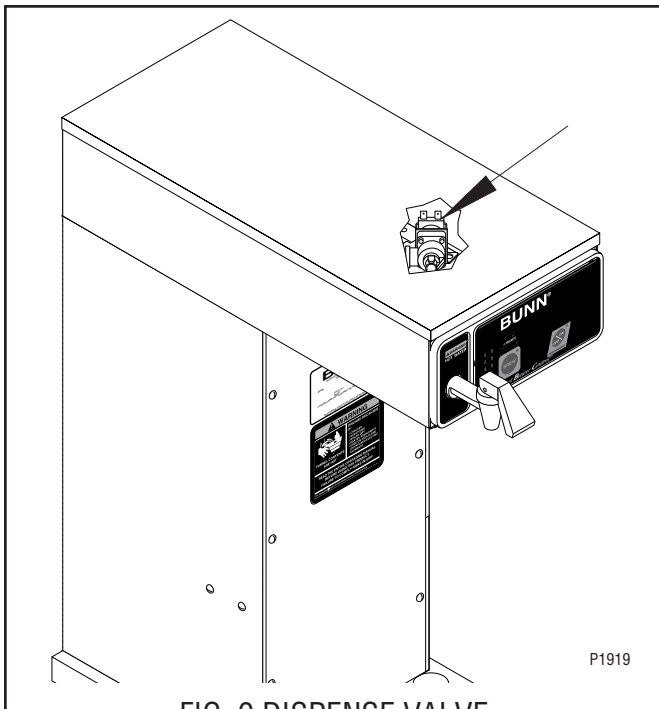

Location:

The dispense valve is located inside the top cover behind the front end cap.

Test Procedures:

1. Disconnect the brewer from the power source.
2. Check the water level in the tank to confirm that it is within 1/2" from the top of the tank.
3. Connect the brewer to the power source. If the brewer has been set for brewer temperature lock-out, this feature must be disabled. See Page 8 for procedure.
4. Check the dispense valve for coil action. Place the ON/OFF switch in the "ON" position, press and release the BREW switch. Listen carefully in the vicinity of the dispense valve for a "clicking" sound as the coil magnet attracts and repels the plunger.
5. Disconnect the brewer from the power source.

If the sound is heard as described, there may be a blockage in the dispense valve or the water line to the sprayhead. Remove the dispense valve and inspect for wear, and remove waterborne particles.

If the sound is not heard as described, proceed to #6.

6. Connect the voltmeter lead ends to the dispense valve coil terminals. Connect the brewer to the power source. Brewer temperature lockout must be disabled. Place "ON/OFF" Switch in the "ON" position. Press and release the brew switch. The indication must be 120 volts ac for two-wire 120 volt models and three-wire 120/208 volt models.
7. Disconnect the brewer from the power source.

If voltage is present as described, but no coil action is observed, nor "clicking" heard, dispense valve is defective. Replace valve and test again to verify repair. If voltage is not present as described, refer to *Wiring Diagrams* and check the brewer wiring harness. Also check the control board for proper operation. See Pages 22 and 23.

Removal and Replacement:

1. Disconnect wires from the dispense valve.
2. Drain enough water from the tank so the dispense valve is above the water level.
3. Remove water lines from the dispense valve.
4. Remove the two #8-32 nuts securing the dispense valve to the sprayhead panel.
5. Install a new dispense valve using the two #8-32 nuts.
6. Reconnect water lines to the dispense valve and secure in place with clamps.
7. Refer to FIG. 10 when reconnecting wires.

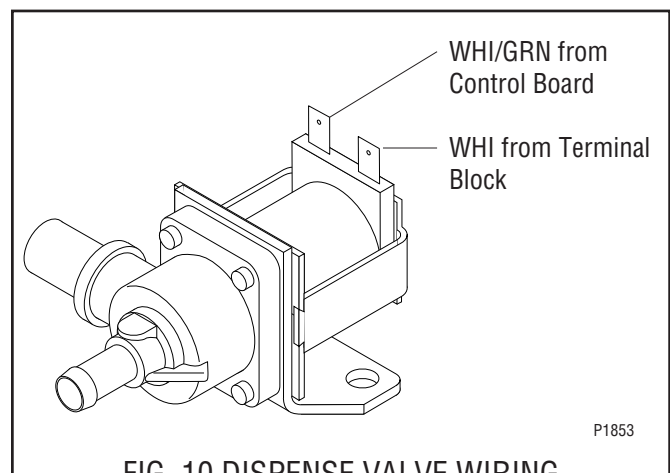

SERVICE (cont.)

TANK HEATER

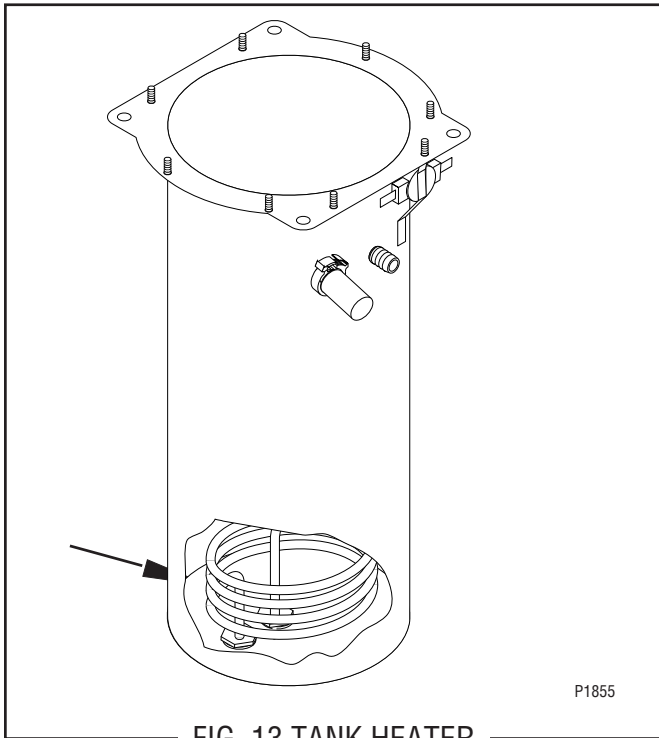

FIG. 13 TANK HEATER

Location:

The tank heater is located inside the tank and secured to the tank bottom.

Test Procedures:

1. Disconnect the brewer from the power supply.
2. With a voltmeter, check the voltage across the white or red wire from the terminal block and the black wire from the control board. Connect the brewer to the power source. The indication must be 120 volts ac for two wire 120 volt models or 240 volts ac for three wire 120/240 volt models.
3. Disconnect the brewer from the power source.

If voltage is present as described, proceed to #4

If voltage is not present as described, refer to the *Wiring Diagrams* and check wiring harness.

4. Disconnect the black wire and the white wire or red wire from the tank heater terminals.
5. Check for continuity across the tank heater terminals.

If continuity is present as described, reconnect the wires, the tank heater is operating properly. If continuity is not present as described, replace the tank heater.

NOTE- If the tank heater remains unable to heat, remove and inspect heater for cracks in the sheath.

Removal and Replacement:

1. Remove the top cover or top warmer housing and front access panel as previously described.
2. Disconnect the vent hose from the top of the tank by pulling the elbow fitting from the grommet in the top of the tank lid.
3. Drain water from the tank.
4. Disconnect the water supply tube to the dispense valve from the side of the tank.
5. Disconnect the water supply tube to the solenoid valve from the bottom of the tank.
6. On brewers with faucet, disconnect the outlet water line to the faucet from the side of the tank.
7. Disconnect the temperature probe from the top of the tank by pulling the probe from the grommet in the top of the tank lid.
8. Disconnect the pink wire from the level probe.
9. Disconnect the green wire from the top of the tank.
10. Disconnect the limit thermostat from the side of the tank.
11. Disconnect the two white wires from the tank warmer blanket.
12. Disconnect the black wire and the white or red wire from the tank heater terminals.
13. Remove the four #8-32 nuts securing the tank to the mounting brackets and remove the tank assembly.
14. Remove the eight #8-32 nuts securing the tank lid to the tank.
15. Remove the two hex nuts securing the tank heater to the bottom of the tank. Remove tank heater with gaskets and discard.
16. Install new tank heater with gaskets to the bottom of the tank and secure with two hex nuts.

SERVICE (cont.)

TANK HEATER (Cont.)

17. Install tank assembly onto mounting brackets and secure in place with four #8-32 nuts.
18. Install tank lid and secure in place with eight #8-32 nuts.
19. Connect the two white wires of the tank warmer blanket.
20. Connect the limit thermostat to the front of the tank assembly.
21. Connect the green wire to the tank mounting bracket using #8-32 nut.
22. Connect the pink wire to the level probe.
23. Insert the temperature probe through the grommet in the tank lid.
24. Install the elbow fitting of the vent hose into the grommet in the tank lid.
25. On brewers with faucet, connect the outlet water line of the faucet to the side of the tank and secure with clamp.
26. Connect the water supply tube from the solenoid to the bottom of the tank and secure with clamp.
27. Connect the water supply tube from the dispense valve to the side of the tank and secure with clamp.
28. Refer to FIG. 14 when reconnecting the tank heater wires.
29. Install access panels and covers and refer to *Initial Set-up* for refill and operation.

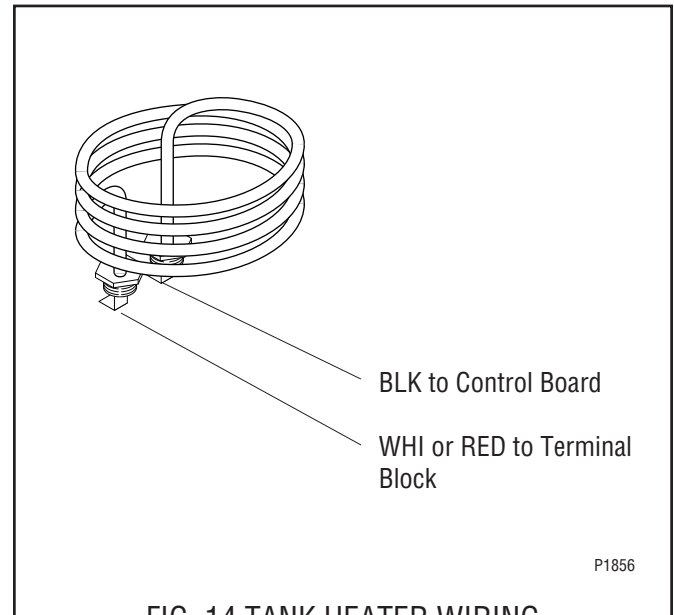
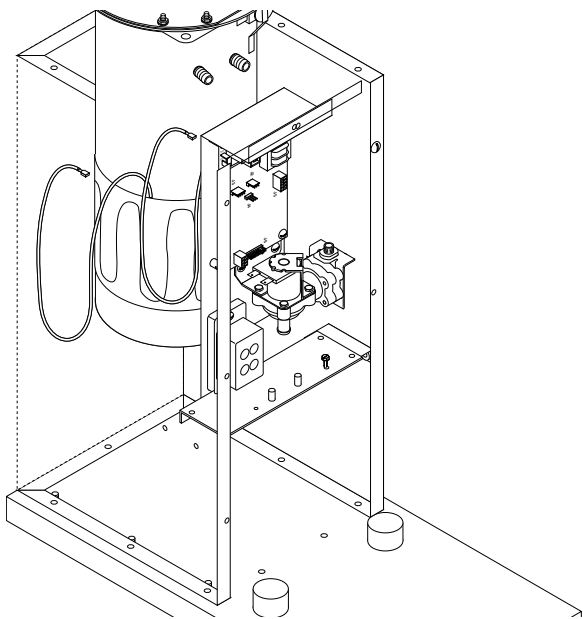
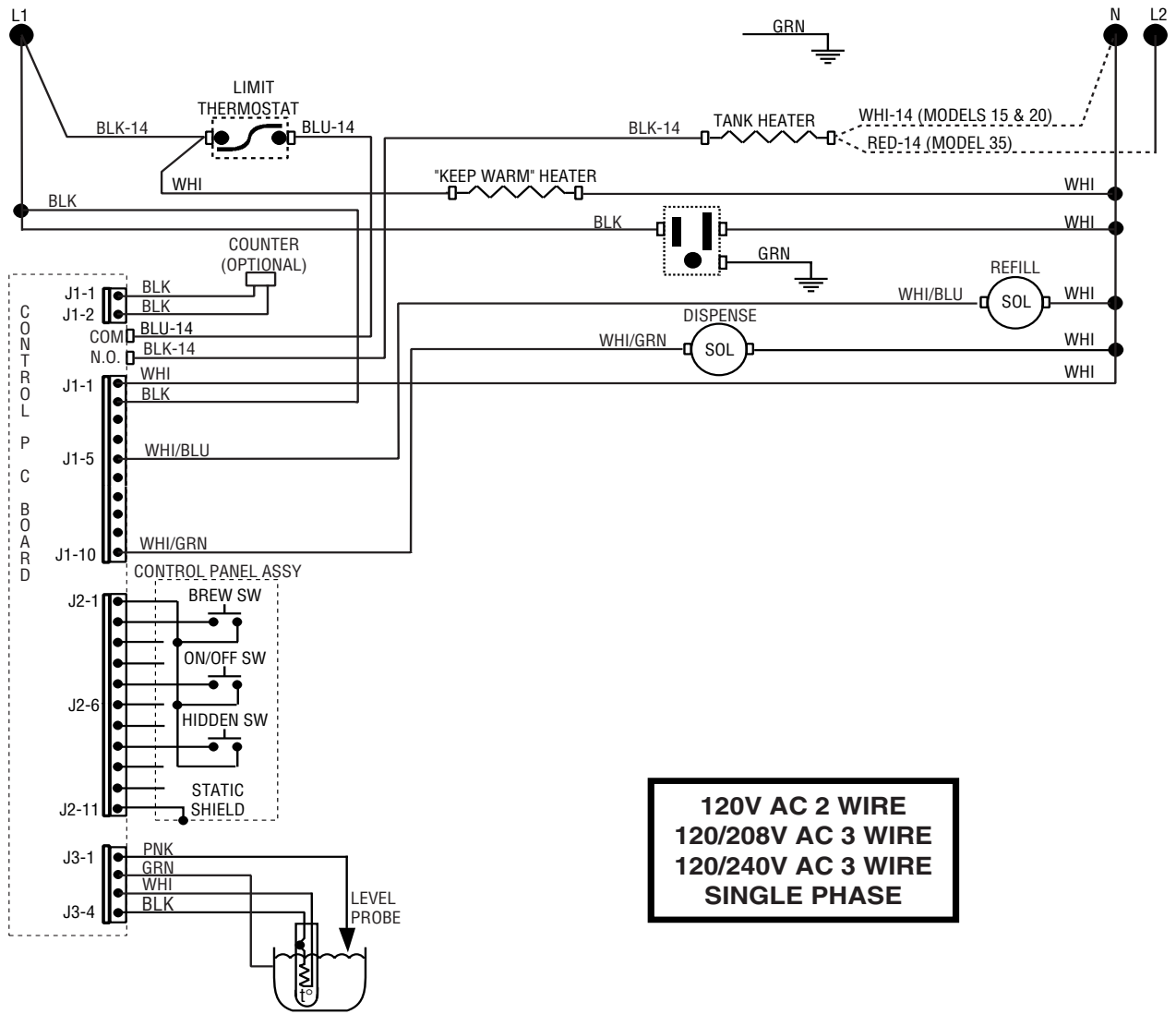

FIG. 14 TANK HEATER WIRING



SCHEMATIC WIRING DIAGRAM CDBC-APS/TS/TSR



120V AC 2 WIRE
120/208V AC 3 WIRE
120/240V AC 3 WIRE
SINGLE PHASE

SCHEMATIC WIRING DIAGRAM CEZ-APS/TS/TSR

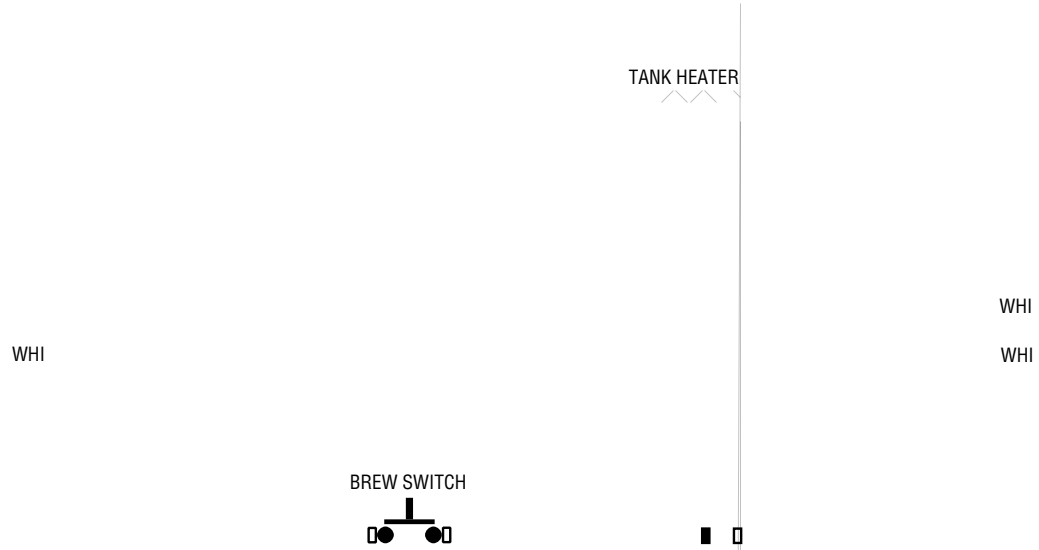

29341.0000B 6/99 ©1998 BUNN-O-MATIC CORPORATION