

**DEWALT**®

# DP1550

## OPERATOR'S MANUAL

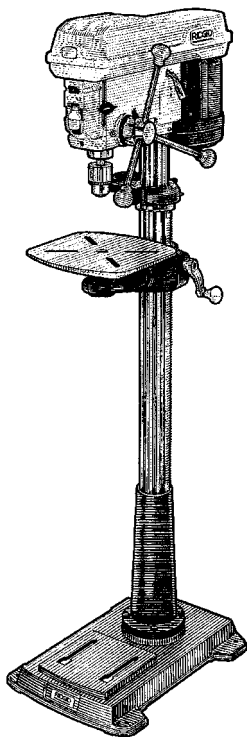

### 15 INCH FLOOR MODEL DRILL PRESS

**⚠ WARNING:** To reduce the risk of injury, the user must read and understand the operator's manual before using this product.

**SAVE THIS MANUAL FOR  
FUTURE REFERENCE**

## Table of Contents

---

Section	Page	Section	Page
Table of Contents .....	2	Adjusting the Table Square To Head .....	19
Safety Instructions For Drill Press .....	2	Bevel Scale .....	19
Safety Symbols .....	2	Converting From Right Hand Operation to Left Hand Operation .....	20
Before Using The Drill Press .....	3	Quill Return Spring .....	22
When Installing Or Moving The Drill Press ....	3	Adjusting Belt Latch Guard .....	23
Before Each Use .....	4	Getting To Know Your Drill Press .....	24
Use Only Accessories Designed For This Drill Press To Reduce The Risk of Serious Injury From Thrown Broken Parts Or Work Pieces .	4	Spindle Speed in R.P.M. ....	25
Plan Ahead To Protect Your Eyes, Hands, Face and Ears .....	6	Drilling to a Specific Depth .....	27
Glossary of Terms .....	7	Another Way - Depth Scale .....	27
Motor Specifications and Electrical Requirements .....	7	Locking Chuck at Desired Depth .....	28
110-120 Volt, 60 Hz. Tool Information .....	8	Removing Chuck and Arbor .....	28
Motor Safety Protection .....	9	Safety Instructions for Basic Drill Press Operation .....	29
Unpacking and Checking Contents .....	10	Plan Ahead To Protect Your Eyes, Hands, Face and Ears .....	29
Tools Needed .....	10	Use Only Accessories Designed For This Drill Press To Reduce the Risk of Serious Injury From Thrown Broken Parts Or Work Pieces	30
Unpacking .....	10	Basic Drill Press Operation .....	30
List of Loose Parts .....	11	Installing Drills .....	30
Loose Parts in Box and Bag .....	11	Positioning Table and Workpiece .....	31
Location and Function of Controls .....	12	Tilting Table .....	32
Assembly .....	13	Hole Location .....	32
Assembly of Base/Column .....	13	Feeding .....	32
Installing The Table .....	14	Maintenance .....	33
Installing the Storage Tray .....	14	Lubrication .....	33
Installing the Head .....	15	Wiring Diagram .....	33
Pulley Alignment and Speed Adjustment ..	16	Troubleshooting .....	33
Tensioning Belt .....	17	Repair Parts .....	35
Installing Feed Handles .....	17		
Installing the Drill Chuck .....	17		
Installing Light Bulb .....	19		

## Safety Instructions For Drill Press

---

### Safety Symbols

**⚠ DANGER:** indicates an imminently hazardous situation which, if not avoided, will result in death or serious injury.

**⚠ WARNING:** indicates a potentially hazardous situation which, if not avoided, could result in death or serious injury.

**⚠ CAUTION:** indicates a potentially hazardous situation which, if not avoided, may result in minor or moderate injury. It may also be used to alert against unsafe practices that may cause property damage.

**NOTE:** Advises you of information or instructions vital to the operation or maintenance of the equipment.

### **⚠ WARNING:**

Do not attempt to use the tool until you have read thoroughly and understand completely the operator's manual. Pay close attention to the safety rules, including Dangers, Warnings, and Cautions. If you use this tool properly and only for what it is intended, you will enjoy years of safe, reliable service.

## Before Using The Drill Press

**⚠ WARNING:** Some dust created by power sanding, sawing, grinding, drilling, and other construction activities contains chemicals known (to the State of California) to cause cancer, birth defects or other reproductive harm. Some examples of these chemicals are:

- Lead from lead-based paints,
- Crystalline silica from bricks and cement and other masonry products, and
- Arsenic and chromium from chemically-treated lumber.

Your risk from these exposures varies, depending on how often you do this type of work. To reduce your exposure to these chemicals: work in a well ventilated area, and work with approved safety equipment, such as those dust masks that are specially designed to filter out microscopic particles.

**⚠ WARNING:** To reduce the risk of mistakes that could cause serious, permanent injury, do not plug the drill press in until the following steps have been satisfactorily completed.

- Completely assemble and align drill press (See “Assembly” section).
- Learn the use and function of the ON-OFF switch. (See “Getting to Know Your Drill Press” section).
- Review and understand all safety instructions and operating procedures in this manual.
- Review the maintenance methods for this drill press (See “Maintenance” section).
- Find and read all the warning labels found on the drill press (shown below).

⚠ WARNING	⚠ ADVERTENCIA	⚠ AVERTISSEMENT
<ol style="list-style-type: none"> <li>To reduce the risk of injury, read and understand the operator's manual before using this press.</li> <li>Read safety symbols that meet ANSI Z39.1 or in Canada CSA 2943-99 standards.</li> <li>Do not wear gloves, ties, or loose fitting clothing. Tie back long hair.</li> <li>To prevent eye injury, always use eye safety or face a safety shield.</li> <li>Use recommended accessories only.</li> <li>Use the recommended speed for the drill accessory.</li> <li>Remove check key before turning power ON.</li> <li>Turn off all tools before operation of drill press.</li> <li>Turn power OFF and wait for drill to stop before adjusting or servicing.</li> <li>Do not expose the arm or use in a damp location.</li> <li>Plug power cord into a properly grounded outlet supported by its own circuit breaker or time delay fuse. In Canada use time delay fuse marked "TC".</li> <li>When servicing, use only identical replacement parts.</li> </ol>	<ol style="list-style-type: none"> <li>Para reducir el riesgo de lesiones, lea y entienda el manual del operador antes de utilizar el taladro de mano.</li> <li>Use un símbolo de seguridad que cumpla con los normos ANSI Z39.1 o en el Canadá, los normos CSA 2943-99.</li> <li>No use guantes, corbatas ni ropas que se puedan enganchar. Sujétense el pelo largo detrás de la cabeza.</li> <li>Para evitar que la pieza de trabajo gire, sujétela con un sujetador o a la mesa o sujétela contra la columna.</li> <li>Utilice accesorios recomendados únicamente.</li> <li>Use la velocidad recomendada para el accesorio de taladro.</li> <li>Quite la llave de seguridad antes de ENCENDERS el taladro.</li> <li>Asegure todos los piezas de fijación antes de utilizar el taladro de mano.</li> <li>APAGUE el taladro y espere a que el broca se detenga antes de realizar ajustes o reparaciones.</li> <li>No exponer la brazo ni usar en lugares húmedos.</li> <li>Conecte el cable en un enchufe con protección de tierra apropiada, protegido con un interruptor automático o fusible retardado de su respuesta. En el Canadá, use fusibles retardados marcados con la letra "TC".</li> <li>Al ser servicio a la unidad, sólo utilice piezas de repuesto idénticas.</li> </ol> <p>PATENT PENDING PATENTE EN TRAMITE BREVET EN INSTANCE</p>	<ol style="list-style-type: none"> <li>Pour réduire le risque de blessures, l'utilisateur doit lire et bien comprendre le manuel d'instructions avant d'utiliser la perceuse à colonne.</li> <li>Prêter les symboles de protection conformes à la norme ANSI Z39.1.</li> <li>Ne porter pas de gants, de corset ou de vêtements amples. Attacher les cheveux longs.</li> <li>Fixer la pièce au plateau ou s'écarter contre la colonne pour éviter qu'elle tourne.</li> <li>Seulement utiliser l'accessoire recommandés.</li> <li>Prenez la vitesse recommandée pour l'accessoire.</li> <li>Retirez la clé de sécurité avant de mettre l'unité en marche.</li> <li>Retirez tous les accessoires avant de mettre la perceuse à colonne en marche.</li> <li>Coupez l'alimentation de l'unité, que la perceuse à colonne soit arrêtée sur un ajustement ou des réparations.</li> <li>Ne touchez pas l'arbre à la fois et ne l'utilisez que dans un endroit sec.</li> <li>Insérez le câble électrique dans une prise mise à la terre et protégée par un dispositif de 15 ampères ou par un fusible temporaire. Au Canada, utilisez un fusible temporaire marqué "TC".</li> <li>Ne pas exclusivement des pièces identiques à celles d'origine pour les réparations.</li> </ol> <p>Spinlock Rotation CULIUS Rotation du huso L'ETI Tournage sur axe 120 V ~ 60 Hz 8,2 A E1841</p>



## When Installing Or Moving The Drill Press

### Reduce the Risk of Dangerous Environment.

- Use the drill press in a dry, indoor place protected from rain.
- Keep work area well lighted.
- Use recommended accessories. The use of improper accessories may cause risk of injury to persons.

### To reduce the risk of injury from unexpected drill press movement.

If there is any tendency of the drill press

to tilt or move during any use, bolt it to the floor. Make sure and leave adequate room to fully open the belt guard. If the workpiece is too large to easily support with one hand, provide an auxiliary support.

- To reduce the risk of injury from electrical shock, make sure your fingers do not touch the plug's metal prongs when plugging in or unplugging the drill press.

## Safety Instructions For Drill Press (continued)

---

- **Never Stand On Tool.** Serious injury could occur if the tool tips or you accidentally hit the cutting tool.

Do not store anything above or near the tool where anyone might stand on the tool to reach them.

---

### Before Each Use

#### Inspect your drill press.

- To reduce the risk of injury from accidental starting, turn the switch off, unplug the drill press, and remove the switch key before raising the guard, changing the cutting tool, changing the setup, or adjusting anything. Make sure switch is in OFF position before plugging in.
- Check for alignment of moving parts, binding of moving parts, breakage of parts, drill press stability, and any other conditions that may affect the way the drill press works.
- If any part is missing, bent or broken in any way, or any electrical part does not work properly, turn the drill press off and unplug the drill press.
- Replace damaged or missing parts before using the drill press again.
- Remove adjusting keys and wrenches. Form a habit of checking for and removing keys and adjusting wrenches from table top before turning drill press on.
- Make sure all clamps and locks are tight and no parts have excessive play.

---

### Use Only Accessories Designed For This Drill Press To Reduce The Risk of Serious Injury From Thrown Broken Parts Or Work Pieces

- When cutting large diameter holes:
  - Clamp the workpiece firmly to the table. Otherwise the cutting tool may grab and spin it at high speed.
  - Use only one piece, cup-type, hole cutters.
  - **Do not** use fly cutters or multi-part hole cutters as they can come apart or become unbalanced in use.
  - Keep speed below 1500 R.P.M.
- Drum sanders must **never** be operated on this drill press at a speed greater than 1800 R.P.M.
- Do not install or use any drill that exceeds 7" in length or extends 6" below the chuck jaws. They can suddenly bend outward or break.
- Do not use wire wheels, router bits, shaper cutters, circle (fly) cutters or

rotary planers on this drill press.

#### Thrown Workpiece

- Thrown Workpiece is the grabbing of the workpiece by the rotating tool. The workpiece can be thrown at a very high speed in the direction of rotation. **This Can Cause Serious Injury.** To reduce the possibility of injury from thrown work:
  - Clamp the workpiece firmly to the table whenever possible.
  - Buffing or sanding wheels or drums should be contacted on the side moving away from you, not the side moving toward you.
  - Use only recommended accessories and follow the instructions supplied with the accessory.

**This drill press has 12 speeds as listed below:**

300 RPM	1100 RPM
400 RPM	1600 RPM
450 RPM	1700 RPM
600 RPM	1900 RPM
650 RPM	2600 RPM
700 RPM	3100 RPM

See inside of guard for specific placement of belt on pulleys.

**Think Safety**

**⚠ WARNING:** Do not allow familiarity (gained from frequent use of your drill press) to become commonplace. Always remember that a careless fraction of a second is sufficient to inflict severe injury.

**Plan Your Work**

- Don't force the tool. It will do the job better and safer at the rate for which it was designed.
- Use the right tool. Don't force tool or attachment to do a job it was not designed to do.
- If any part of your drill press is missing, malfunctioning, has been damaged or broken...such as the motor switch, or other operating control, a safety device or the power cord, turn the drill press off and unplug it until the particular part is properly repaired or replaced.
- Never place your fingers in a position where they could contact the drill or other cutting tool if the workpiece should unexpectedly shift or your hand should slip.
- Keep guards in place and in working order.
- To reduce the risk of injury from parts thrown by the spring, follow instructions exactly as given and

shown in adjusting spring tension of quill.

- To prevent the workpiece from being torn from your hands, spinning of the tool, shattering the tool or being thrown, always properly support your work so it won't shift or bind on the tool:
  - Always position backup material (use beneath the workpiece) to contact the left side of the column.
  - Whenever possible, position the workpiece to contact the left side of the column - If it is too short or the table is tilted, clamp solidly to the table. Use table slots or clamping ledge around the outside edge of the table.
  - When using a drill press vise, always fasten it to a table.
  - Never do any work "Freehand" (hand holding workpiece rather than supporting it on the table), except when polishing.
  - Securely lock head to column, table support to column and table to table support before operating drill press.
  - Never move the head or table while the tool is running.
  - Before starting the operation, jog the motor switch to make sure the drill or other cutting tool does not wobble or cause vibration.
  - If a workpiece overhangs the table such that it will fall or tip if not held, clamp it to the table or provide auxiliary support.
  - Use fixtures for unusual operations to adequately hold, guide and position workpiece.

## Safety Instructions For Drill Press (continued)

- Use the spindle speed recommended for the specific operation and workpiece material - check the inside of the belt guard for drilling information; for accessories, refer to the instructions provided with the accessories.
- Never climb on the drill press table, it could break or pull the entire drill press down on you.
- Turn the motor switch off and put away the switch key when leaving the drill press.
- To reduce the risk of injury from thrown work or tool contact, do not perform layout, assembly or setup work on the table while the cutting tool is rotating.
- Don't overreach. Keep proper footing and balance at all times.
- Maintain tools with care. Keep tools sharp and clean for best and safest performance. Follow instructions for lubricating and changing accessories.

---

### Plan Ahead To Protect Your Eyes, Hands, Face and Ears

#### Dress for safety

- Do not wear loose clothing, gloves, neckties or jewelry (rings, wrist watches). They can get caught and draw you into moving parts.
- Wear nonslip footwear.
- Tie back long hair.
- Roll long sleeves above the elbow.
- Noise levels vary widely. To reduce the risk of possible hearing damage, wear ear plugs or muffs when using drill press for hours at a time.
- Any power tool can throw foreign objects into the eyes. This can result in permanent eye damage. Always wear safety goggles, not glasses complying with ANSI Z87.1 (or in Canada CSA Z94.3-99) shown on package. Everyday eyeglasses have only impact resistant lenses. They are not safety glasses. Safety goggles are available at many local retail stores. Glasses or goggles not in compliance with ANSI or CSA could seriously hurt you when they break.



- For dusty operations, wear a dust mask along with safety goggles.

#### Reduce the Risk of Accidental Starting.

- Make sure switch is "OFF" before plugging drill press into a power outlet.

**⚠ WARNING:** Don't allow familiarity (gained from frequent use of your drill press) to cause a careless mistake. Always remember that a careless fraction of a second is enough to cause a severe injury.

#### Keep Children Away

- Keep all visitors a safe distance from the drill press.
- Make sure bystanders are clear of the drill press and workpiece.

#### Before Leaving The Drill Press

- Turn the drill press off.
- Wait for tool bit to stop spinning.
- Unplug the drill press.
- Make workshop child-proof. Lock the shop. Disconnect master switches. Remove the yellow switch key. Store it away from children and others not qualified to use the tool.

## Glossary of Terms

### Workpiece

The item on which the cutting operation is being performed.

### Drill Bit or Drill

The cutting tool used in the drill press to make holes in a workpiece.

### Backup Material

A piece of wood placed between the workpiece and table...it prevents wood in the workpiece from splintering when the drill passes through the backside of the

workpiece...also prevents drilling into the table top.

### Revolutions Per Minute (R.P.M.)

The number of turns completed by a spinning object in one minute.

### Spindle Speed

The R.P.M. of the spindle.

### Backlash

The amount of handle movement or play between adjacent moving parts.

## Motor Specifications and Electrical Requirements

### Power Supply and Motor Specifications

**⚠ WARNING:** To reduce the risk of electrical hazards, fire hazards or damage to the tool, use proper circuit protection. Your tool is wired at the factory for operation using the voltage shown. Connect tool to a power line with the appropriate voltage and a 15-amp branch circuit. Use a 15-amp time delay type fuse or circuit breaker. To reduce the risk of shock or fire, if power cord is worn or cut, or damaged in any way, have it replaced immediately.

The A-C motor used on this tool is a totally enclosed fan cooled (TEFC), induction nonreversible type, having the following specifications:

Rated H.P	1/2
Voltage	110-120
Amperes	8.0
Hertz (Cycles)	60
Phase	Single
RPM	1700
Rotation of Shaft	Clockwise

### General Electrical Connections

**⚠ DANGER:** To reduce the risk of electrocution:

1. Use only identical replacement parts when servicing. Servicing should be performed by a qualified service technician.
2. Do not use in rain or where floor is wet.

This tool is intended for indoor residential use only.

**⚠ WARNING:** Do not permit fingers to touch the terminals of plug when installing or removing the plug to or from the outlet.

#### SYMBOL



#### MEANING

Do not expose to rain or use in damp locations.

**SAVE THESE INSTRUCTIONS**

## Motor Specifications and Electrical Requirements (continued)

### 110-120 Volt, 60 Hz. Tool Information

**NOTE:** The plug supplied on your tool may not fit into the outlet you are planning to use. Your local electrical code may require slightly different power cord plug connections. If these differences exist refer to and make the proper adjustments per your local code before your tool is plugged in and turned on.

In the event of a malfunction or breakdown, grounding provides a path of least resistance for electric current to reduce the risk of electric shock. This tool is equipped with an electric cord having an equipment grounding conductor and a grounding plug, as shown. The plug must be plugged into a matching outlet that is properly installed and grounded in accordance with all local codes and ordinances.

Do not modify the plug provided. If it will not fit the outlet, have the proper outlet installed by a qualified electrician.

Improper connection of the equipment grounding conductor can result in a risk of electric shock. The conductor with insulation having an outer surface that is green with or without yellow stripes is the equipment grounding conductor. If repair or replacement of the electric cord or plug is necessary, do not connect the equipment-grounding conductor to a live terminal.

If the grounding instructions are not completely understood, or if you are in doubt as to whether the tool is properly grounded check with a qualified electrician or service personnel.

**⚠ WARNING:** If not properly grounded, this tool can cause an electrical shock, particularly when used in damp locations, in proximity to plumbing, or outdoors. If an electrical shock occurs there is the potential of a secondary hazard, such as your hands to hit the cutting tool.

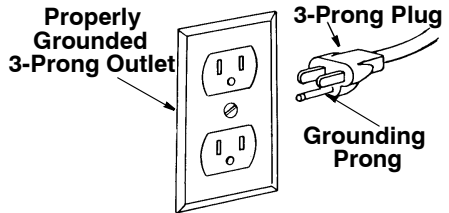



## Motor Safety Protection

**IMPORTANT:** To avoid motor damage, this motor should be blown out or vacuumed frequently to keep sawdust from interfering with normal motor ventilation.

1. Connect this tool to a power source with the appropriate voltage for your model and a 15-amp branch circuit with a 15-amp time delay fuse or circuit breaker. Using the wrong size fuse can damage the motor.
2. If the motor won't start, turn the switch off immediately and unplug the tool. Check the quill to make sure it turns freely. If the quill is free, try to start the motor again. If the motor still does not start, refer to the "Motor Troubleshooting Chart."
3. Fuses may "blow" or circuit breakers may trip frequently if:

- a. **Motor Is Overloaded** - Overloading can occur if you feed too rapidly or make too many start/stops in a short time.
  - b. Line voltages should not be more than 10% above or below the nameplate voltage. For heavy loads, however, the voltage at motor terminals must equal the voltage specified for your model.
  - c. Improper or dull drill bit is used.
4. Most motor troubles may be traced to loose or incorrect connections, overload, low voltage (such as small size wire in the supply circuit) or to overly long supply circuit wire. Always check the connections, the load and the supply circuit whenever motor doesn't work well. Check wire sizes and length with the Wire Size Chart shown.

---

## Wire Sizes

**NOTE:** Make sure the proper extension cord is used and is in good condition.

The use of any extension cord will cause some loss of power. To keep this to a minimum and to prevent overheating and motor burnout, use the table at right to determine the minimum wire size (A.W.G.) extension cord.

Use only 3-wire extension cords which have 3-prong grounding type plugs and 3-

pole receptacles which accept the tools plug.

Extension Cord Length	Gauge (A.W.G.)
0-25	16
25-50	14

# Unpacking and Checking Contents

---

## Tools Needed

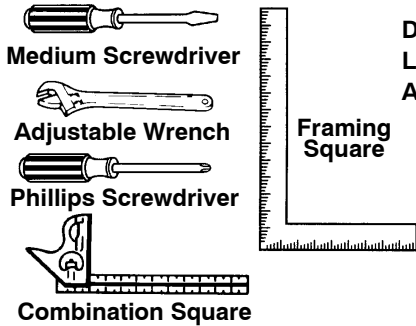

Combination Square Must be True  
Draw Light  
Line on Board  
Along this Edge

Straight Edge of  
Board 3/4" Thick  
This Edge Must be  
Perfectly Straight

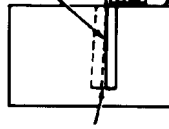

Should be no Gap or Overlap when Square  
is Flipped Over in Dotted Position

---

## Unpacking

**⚠ WARNING:** For your own safety, never connect plug to power source outlet until all assembly steps are complete, and you have read and understood the safety and operating instructions.

The Drill Press is shipped complete in one box.

1. Separate all "loose parts" from packing materials and check each item with illustration and "Table of Loose Parts."

**⚠ WARNING:** To reduce the risk of injury, if any parts are missing, do not attempt to assemble the drill press, plug in the power cord, or turn the switch on until the missing parts are obtained and installed correctly.

2. Remove the protective oil that is applied

to the table and column. Use any ordinary household type grease and spot remover.

**⚠ WARNING:** To reduce the risk of fire or toxic reaction, never use gasoline, naphtha or similar highly volatile solvents to remove protective oil.

3. Apply a coat of paste wax to the table and column to prevent rust. Wipe all parts thoroughly with a clean dry cloth.

**NOTE:** Make certain all items are accounted for before discarding any packing material.

## List of Loose Parts

Item	Description	Qty.
A	Head Asm. ....	1
B	Table.....	1
C	Column Support Assembly.....	1
D	Base.....	1
E	Bag Chuck.....	1
F	Bag of Loose Parts ..(Quantity varies)	
G	Operator's Manual .....	1
H	Key Switch, Feed Handle, Wrench...1	
I	Belts.....	2
J	Idler Pulley.....	1

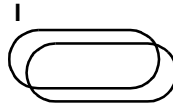
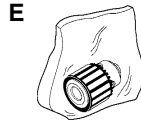
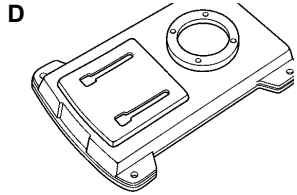
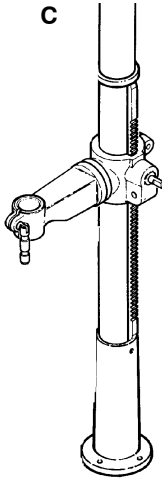
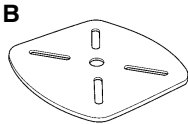
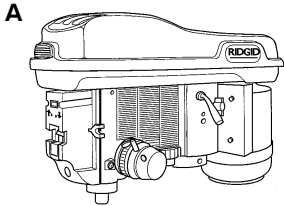

## Loose Parts

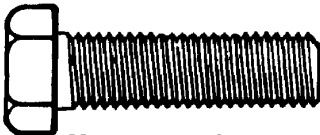

M10 x 1.5-40 Long  
Hex Head Bolt (4)

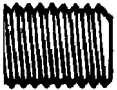

M10 x 1.5-12 Long  
Hex Socket Set Screw (2)

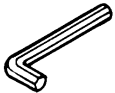

M3 Hex "L" Wrench (1)

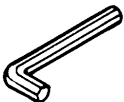

M5 Hex "L" Wrench (1)

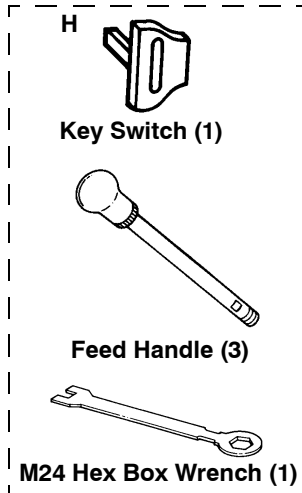

Key Switch (1)

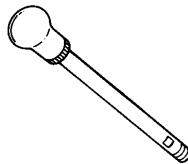

Feed Handle (3)



M24 Hex Box Wrench (1)

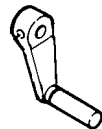

Crank  
(With Set Screw) (1)

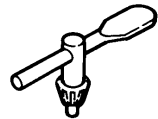

Chuck Key (1)



Support Lock  
Handle (1)



Chuck (1)

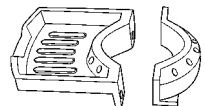

Storage Tray (1)

## Location and Function of Controls

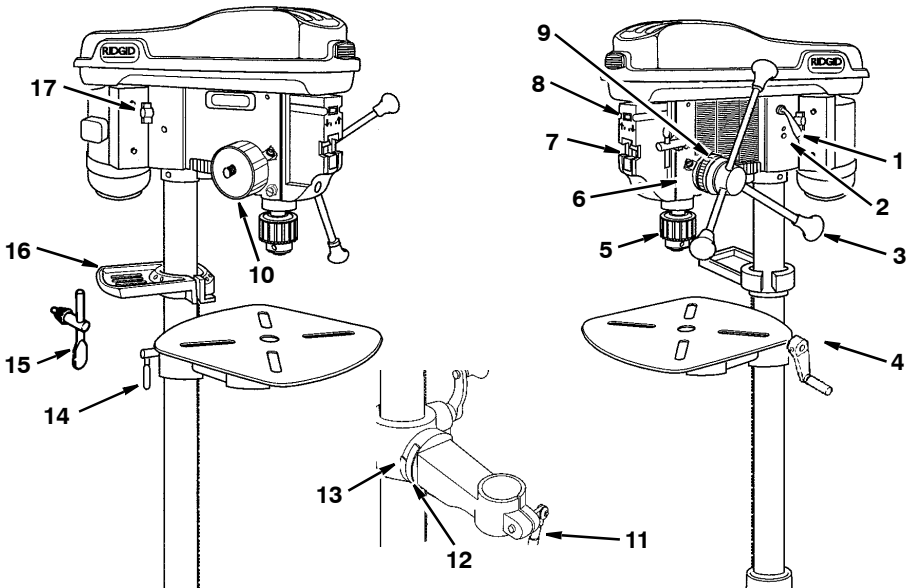

- 1. Belt Tension Handle...**Turn handle counterclockwise to apply tension to belt, turn handle clockwise to release belt tension.
- 2. Head Lock Set Screws...**Locks the head to the column. Always have them locked in place while operating the drill press.
- 3. Feed Handle...**For moving the chuck up or down. One or two of the handles may be removed if necessary whenever the workpiece is of such unusual shape that it interferes with the handles.
- 4. Table Crank...**Turn clockwise to elevate table. Support lock must be released before operating crank.
- 5. Chuck...**Holds drill bit or other recommended accessory to perform desired operations.
- 6. Depth Scale...**Allows operator to adjust drill press to drill to a desired depth.
- 7. Drill "On-Off" Switch...**Has locking feature to prevent unauthorized and possible hazardous use by children and others.
- 8. Light "On-Off" Switch...**Turns the light on and off.
- 9. Depth Scale Lock...**Locks the depth scale at selected depth.
- 10. Spring Cap...**Provides means to adjust quill spring tension.
- 11. Table Lock...**Allows table to be rotated in various positions and locked.
- 12. Table Bevel Lock...**Locks the table in any position from 0° - 45°.
- 13. Bevel Scale...**Shows degree table is tilted for bevel operations. Scale is mounted on side of arm.
- 14. Support Lock Handle...**Tightening locks table support to column. Always have it locked in place while operating the drill press.
- 15. Chuck Key...**Used to tighten drill in the chuck and also to loosen the chuck for drill removal.
- 16. Storage Tray...**Conveniently holds drill bits and other accessories.
- 17. Belt Tension Lock Handles...**Tightening handles locks motor bracket support to maintain correct belt distance and tension.

**Note and follow the safety warnings and instructions that appear on the panel on the right side of the head.**

## Assembly

**⚠ WARNING:** To reduce the risk of injury from unexpected starting or electrical shock, never connect plug to outlet until all assembly steps are completed and you read and understand all instructions.

### Assembly of Base/Column

1. Locate four (4) 10mm dia. x 40mm long bolts among loose parts bag.
2. Position base on floor. Remove protective covering and discard.
3. Remove protective sleeve from column tube and discard. Place column assembly on base, and align holes in column support with holes in base.
4. Install a bolt in each hole through column support and base and tighten with adjustable wrench.



10mm Dia. x 40mm  
Hex Head Bolt (4)

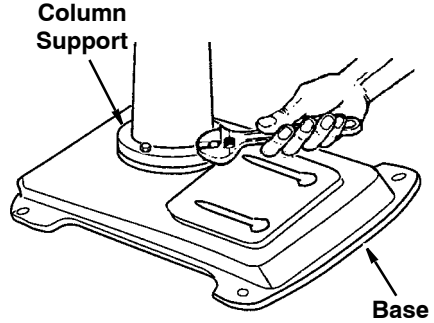

5. Locate table crank and support lock from loose parts.
6. Install support lock from left side into table support and tighten by hand.
7. Install table crank assembly and tighten set screw with a 3mm hex "L" wrench. Do not overtighten. Set screw should be tightened against the flat section of the shaft.

**NOTE:** To minimize crank backlash, tighten support lock, rotate elevation worm shaft clockwise, then assemble crank tight against table support and tighten set screw.

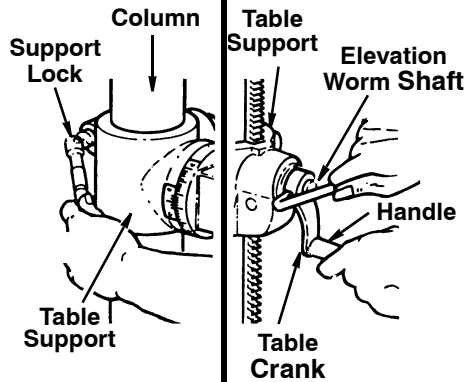

8. Check column collar for proper adjustment. Collar should not be angled on the column and it should be positioned so rack will slide freely in collar when table is rotated 360° around column tube. If readjusted, only tighten set screw enough to keep collar in place.

**NOTE:** To reduce the risk of column or collar damage, do not overtighten set screw.

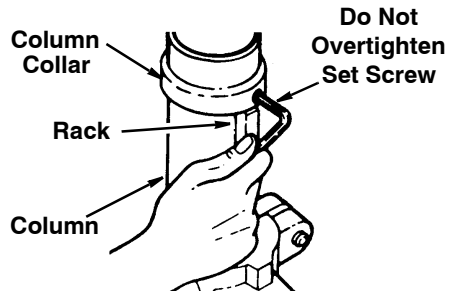

## Assembly (continued)

### Installing The Table

1. Loosen support lock and raise table support by turning table crank clockwise until support is at a working height level. Tighten support lock.

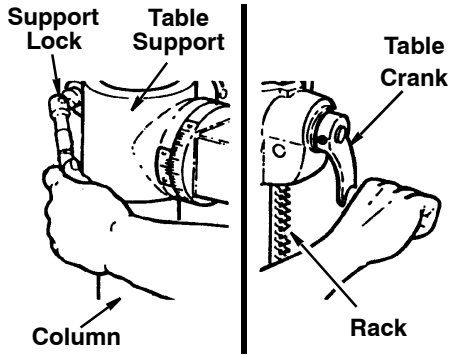

2. Remove protective covering from table and discard. Loosen table lock, place table in table support and tighten table lock (located under table) by hand.

**NOTE:** If table won't fit into table support easily, pry open table support with a flat blade screwdriver.

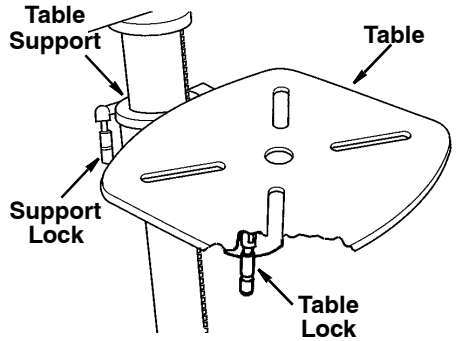

### Installing the Storage Tray

1. Locate the two piece storage tray, (2) two 5mm dia. x 60 mm long screw, and (2) two 5 mm hex nuts.
2. Attach to the column as shown. Make sure the storage tray is located above the column collar. Be careful not to over-tighten the nuts.

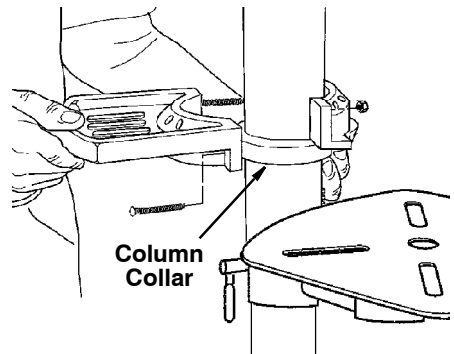
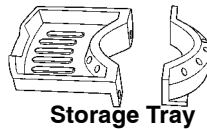
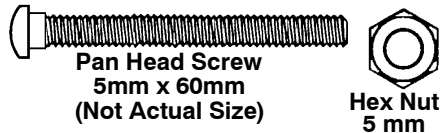

## Installing the Head

**⚠ CAUTION:** The head assembly weighs about 80 pounds. To reduce the risk of back injury get help to lift the head.

1. Locate (2) two 10mm dia. x 12mm long set screws in loose parts bag.
2. Remove protective bag from head assembly and discard. Carefully lift head above column tube and slide it onto column making sure head slides down over column as far as possible. Align head with table and base.

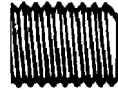

10mm Dia. x 12mm  
Set Screw

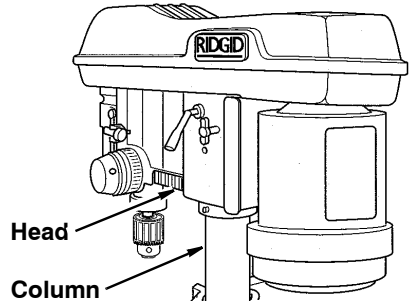

3. Install a set screw in each hole (as indicated) on the right side of the head, and using a 5mm hex "L" wrench, tighten the two head lock set screws.

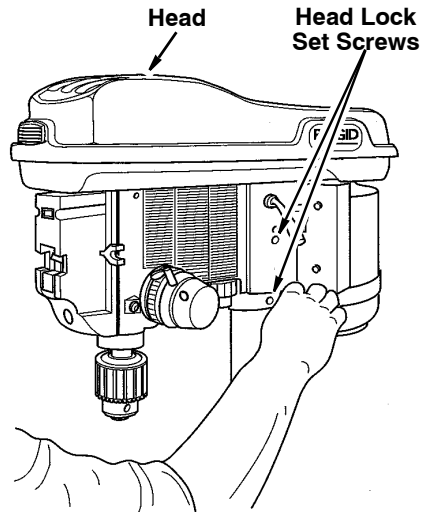

## Assembly (continued)

### Pulley Alignment and Speed Adjustment

#### Checking Pulley(s) Alignment

**⚠ WARNING:** To reduce the risk of injury due to accidental starting always turn drill press off and remove switch key before making belt adjustments.

Pulley alignment is set at the factory and should not require further adjustment.

1. Place the idler pulley from loose parts bag into the head as shown. Place belts from loose parts bag on pulleys following speed adjustment instructions below.
2. Place a straightedge such as a piece of wood, metal, or framing square across the top of pulleys.
3. The top of all three pulleys should touch the straightedge.
4. If not:

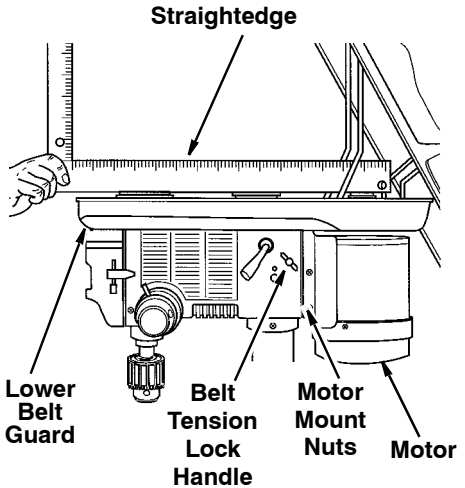

- Loosen the motor mount nuts.
- Move the motor until the pulleys are in line.
- Retighten the motor mount nuts.

**NOTE:** To avoid rattles or other noise, motor frame must not touch lower belt guard.

#### Speed Adjustment

1. Release belt tension lock handles located on each side of drill press head by turning them counterclockwise.
2. Loosen belt tension by turning belt tension handle clockwise.
3. Use speed chart inside belt guard to choose speed for drilling operation. Install belts in correct position for desired speed. **The longer of the two belts is always positioned between the spindle pulley and idler pulley.**

**IMPORTANT:** Visually check to make sure the four ribs on the belt are placed into the four pulley grooves.

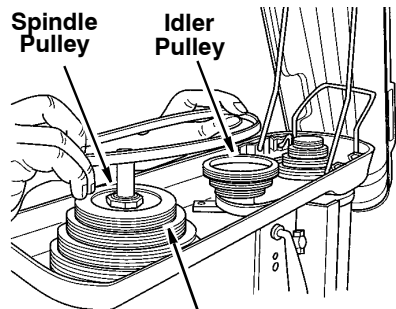
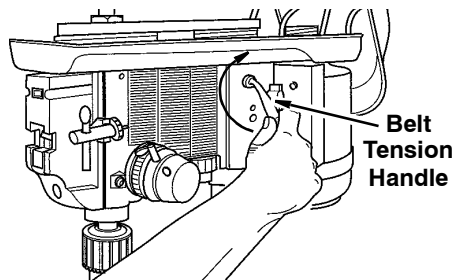

Properly aligned belt should **not** touch the stepped surface on the pulley



## Tensioning Belt

1. Apply tension to belt by turning belt tension handle counterclockwise until belt deflects approximately 1/2 inch by thumb pressure at its center.

2. Tighten belt tension lock handles.

**NOTE:** Over tensioning belt may cause motor not to start or damage bearings.

3. If belt slips while drilling, readjust belt tension. Also make sure the ribs in the belt are aligned with grooves in the pulley.

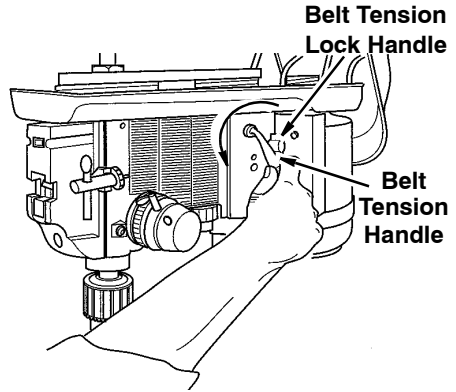

---

## Installing Feed Handles

1. Locate three (3) feed handles among loose parts.

2. Screw the feed handles into the threaded holes in the hub and tighten.

3. Tighten feed handles using the open end of the M24 hex box wrench included with drill press.

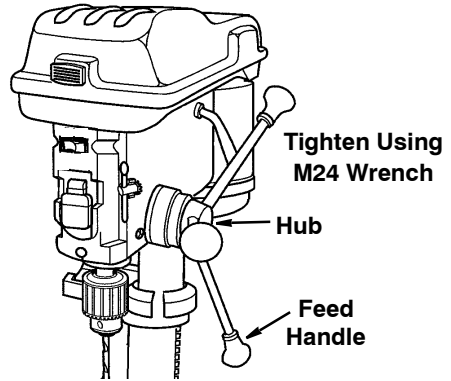

---

## Installing the Drill Chuck

1. Clean the tapered surfaces on the chuck and spindle with a clean cloth. Make sure there are no foreign particles sticking to these surfaces. The slightest piece of dirt on these surfaces will prevent the arbor from seating properly. This will cause the drill to "wobble".

2. Slide chuck into spindle of drill press.

3. Push up on chuck assembly as you rotate it.

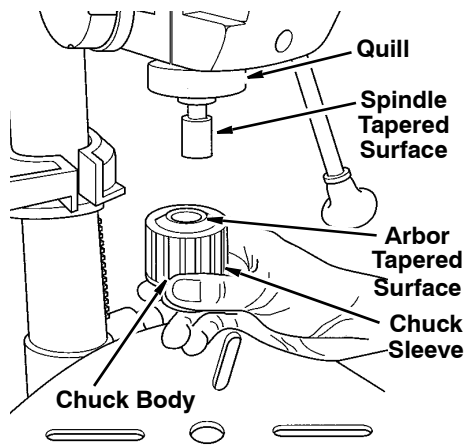

## Assembly (continued)

4. Unlock support lock and raise table so its about two (2) inches below tip of chuck.

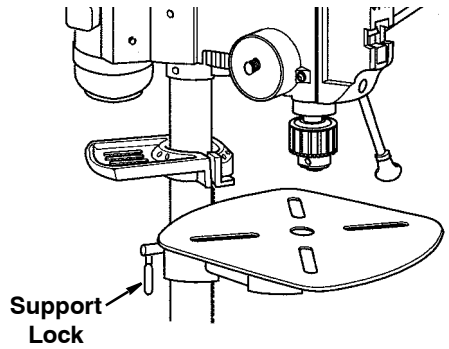

5. Turn chuck sleeve clockwise and open jaws in chuck completely.

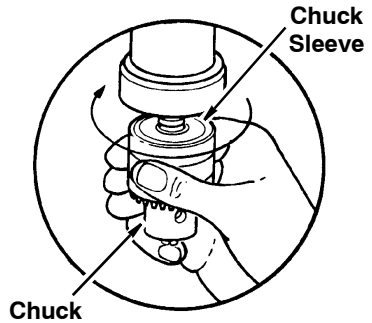

6. Place a piece of wood on table. Turn feed handles counterclockwise and force chuck against table until chuck is secure.

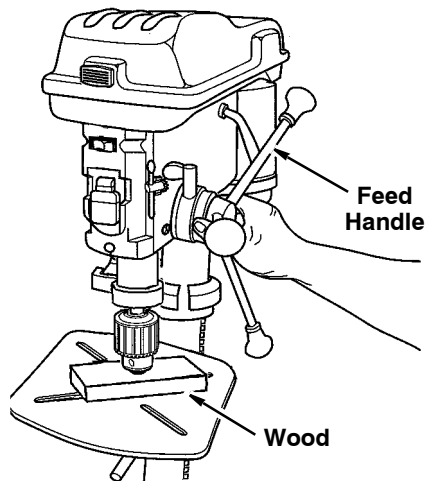

## Installing Light Bulb

**⚠ WARNING:** To reduce the risk of electrical shock, unplug the tool before installing light bulb.

1. Remove the amber colored lens cover by removing the two Phillips screws.
2. Install a light bulb (not larger than 60 watt) into the socket inside the head.
3. Replace the lens cover.

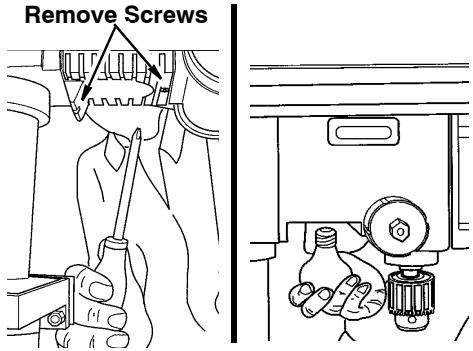

## Adjusting the Table Square To Head

**NOTE:** The combination square must be “true”. See “Unpacking and Checking Contents” section for method.

1. Insert precision round steel rod or straight drill bit approximately 3” long into chuck and tighten.
2. With table raised to working height and locked on column, place combination square flat on table beside rod or bit.
3. If an adjustment is necessary, loosen the set screw under bevel lock with 3mm “L” wrench, then loosen the table bevel lock bolt with the 24mm hex box wrench (included). (This adjustment is located under the table).
4. Align the table square to the rotor bit by rotating table until the square and rod or bit are in line.
5. Retighten table bevel lock.
6. Retighten set screw.

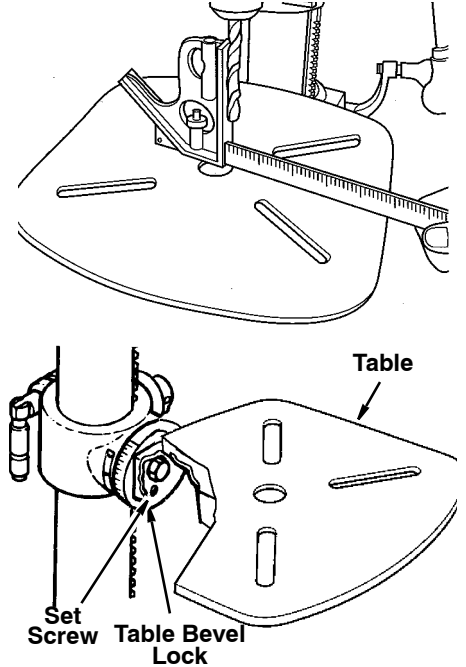

## Bevel Scale

**NOTE:** The bevel scale has been included to provide a quick method for beveling the table to approximate angles. If precise accuracy is necessary, a square, or other precision measuring tool should be used to position the table.

1. To use the bevel scale do the following.
  - a. Loosen set screw and table bevel lock (see step 3 above).
  - b. Move table so desired angle on bevel scale is straight across from zero line on pointer.
  - c. Retighten table bevel lock and set screw.

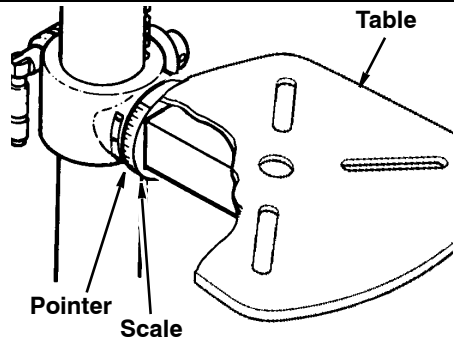

## Assembly (continued)

### Converting From Right Hand Operation to Left Hand Operation

The drill press is shipped from the factory with feed handles set-up for right hand operation. However, if desired, the drill press feed handles can be converted to left hand operation.

**⚠ WARNING:** For your own safety turn switch OFF (O) and remove plug from power source outlet before making any adjustments.

1. To help keep the drill chuck from falling on to the floor, place a piece of scrap wood on top of the table and raise the table until it engages the chuck.

**⚠ CAUTION:** Releasing the spring assembly without proper support of the chuck will allow the quill assembly to drop on top of the drill press table.

2. Firmly hold spring housing against head so it remains engaged with the 4mm cap screw. Remove both M12 nuts and M12 washer from the feed handle assembly shaft.
3. Use both hands to firmly grasp the spring assembly. Pull the spring assembly slightly away from the drill press, disengaging the spring housing from the cap screw. While firmly holding the housing, allow the spring assembly to unwind clockwise until the spring tension is relieved.

**⚠ CAUTION:** To prevent injury, be careful not to allow the spring assembly to rapidly unwind.

4. Remove the spring assembly.
5. Slide the feed handle assembly out from the right side of the head.
6. Remove the bushing located on the left of the head assembly as shown. It may be necessary to tap this bushing out from the right side. Reinstall this bushing on the right side of the drill press.

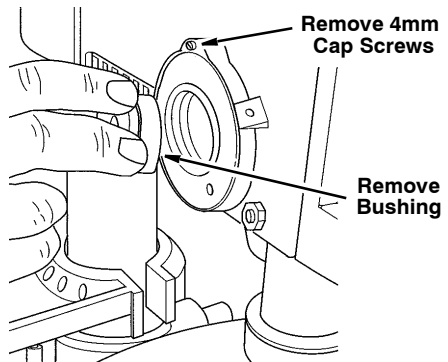
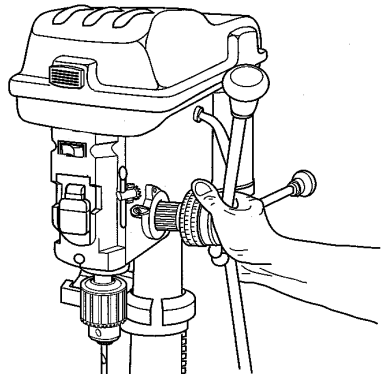
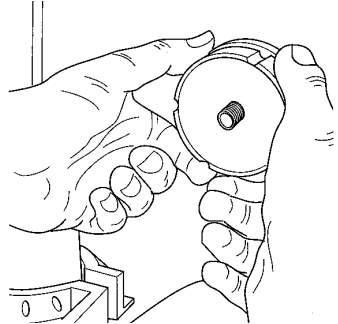
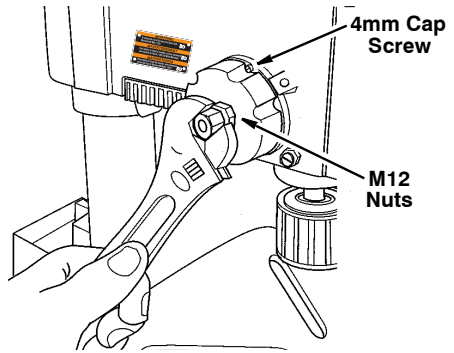

7. Remove the 4mm socket head cap screw from the left side of the drill press and install in the same position on the right side of the drill press. Tighten screw.
8. Remove the 6mm stop pin screw from the right side of the drill press and install in the left side of the drill press as shown. Tighten stop pin screw.
9. Install the feed handle assembly and depth stop ring on the left side of the drill press. With the chuck at its highest possible position, turn the depth scale clockwise until it stops and tighten the depth scale lock. This will prevent the quill from dropping while installing the spring.
10. Install the spring assembly on the right side of the drill press, making sure the two housing screw heads face outwards. The center tab of the spring must go in the slot on the feed handle assembly.

If necessary, use a screwdriver to align and keep spring centered during installation.

11. Replace M12 washer and screw the outer and inner nuts back on the feed handle assembly. Hold the spring assembly in place and loosely assemble both nuts. See following page for quill return spring adjustment.
12. Remove the depth scale and reposition so numbers are legible as shown.
13. Remove the depth scale indicator from the right side of the drill press and reinstall on the left side of the drill press.
14. Remove the scrap wood from the table top.

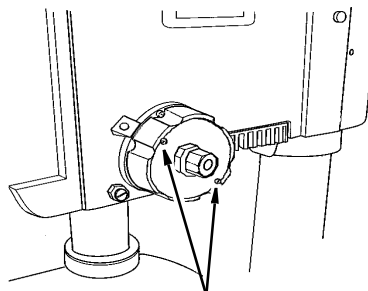
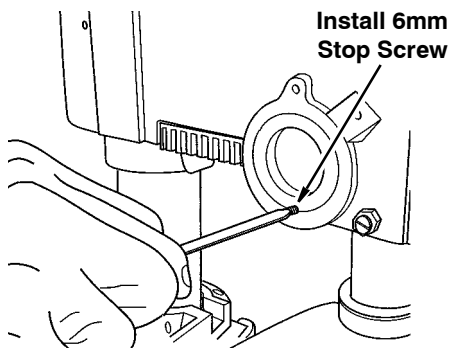

**Right side housing screws face outward as shown**

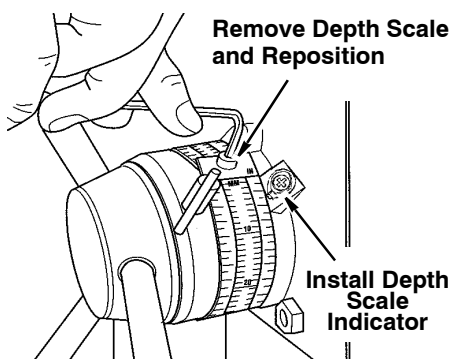
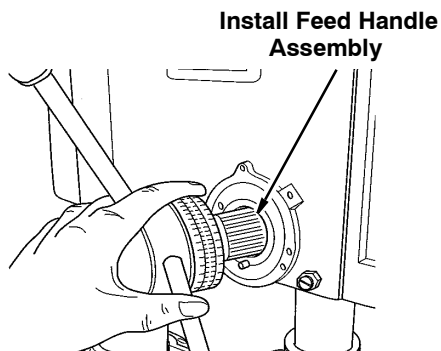

## Assembly (continued)

**⚠ WARNING:** For your own safety turn switch OFF (O) and remove plug from power source outlet before making any adjustments. To reduce the risk of injury from thrown parts due to spring release, follow instructions carefully and wear eye goggles.

### Quill Return Spring

**NOTE:** The return spring tension is set at the factory and should not require further adjustment.

If you switched your drill press from **right** hand operation to **left** hand operation, follow the procedure below to adjust spring tension.

1. With the chuck at its highest possible position, turn the depth scale clockwise until it stops and tighten the depth scale lock. This will prevent the quill from dropping while tensioning the spring.

**NOTE:** For right hand operation (feed handle on right side) turn the depth scale **counterclockwise** until it stops and tighten the depth scale lock.

2. Check to make sure spring housing is mounted correctly. When spring housing is placed on the right side (feed handles mounted on left side), the housing screws face out as shown. When spring housing is placed on the left side (feed handles mounted on right side), the housing screws face toward the head as shown.
3. Lower table for additional clearance.
4. Firmly hold the spring assembly against the head keeping it engaged with the 4mm cap screw while loosening and removing the outer nut only.
5. Loosen inner nut (approximately 1/4 inch) and disengage spring housing from the 4mm cap screw. Using both hands turn spring **clockwise** to the next notch and engage with the 4mm cap screw.

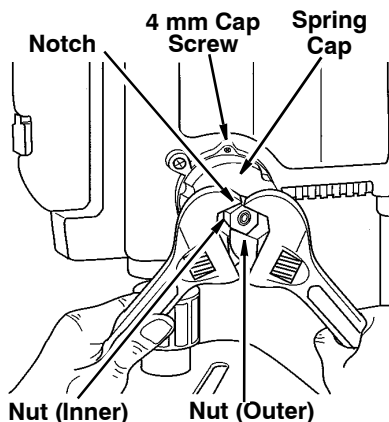

**NOTE:** For right hand operation (feed handle on right side) turn spring **counter-clockwise** to the next notch and engage with the 4mm cap screw.

6. Finger tighten inner nut against spring housing. Do not overtighten as this will restrict quill movement.
7. Loosen depth scale lock and check quill return by rotating feed handles, lowering quill.
8. Proper tension is achieved when quill returns gently to full up position when released from 3/4" depth.
9. If there is not enough tension on spring, repeat steps 5-8 moving only one notch each time and checking tension after each repetition.
10. After adjusting spring, replace outer nut and tighten to inner nut. But do not overtighten against inner nut.
11. Check quill movement to make sure it is smooth and unrestricted. If movement is too tight, loosen outer nut and slightly loosen inner nut until unrestricted. Retighten outer nut.

**Left side housing screws  
face towards head as shown**

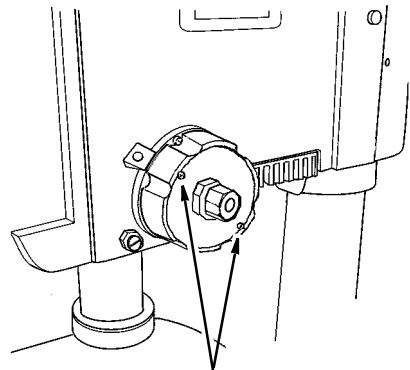
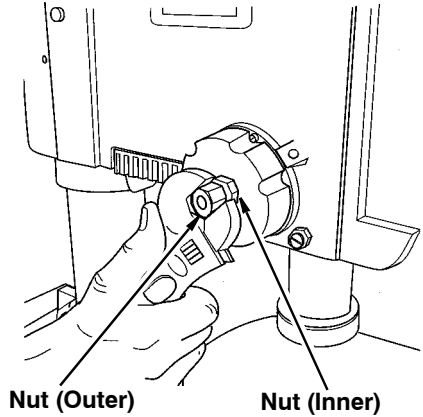

**Right side housing screws  
face outward as shown**

### **Adjusting Belt Latch Guard**

The button latch is adjusted at the factory to be self latching when the pulley guard lid is closed. If adjustment is needed, loosen the two screws securing the latch to the lid and move latch back until the lid closes without depressing the button. The button can also be adjusted up and down to assure lid closes tight by loosening the two screws in back of the latch button, and moving the button up or down as needed.

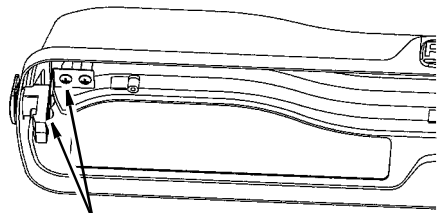





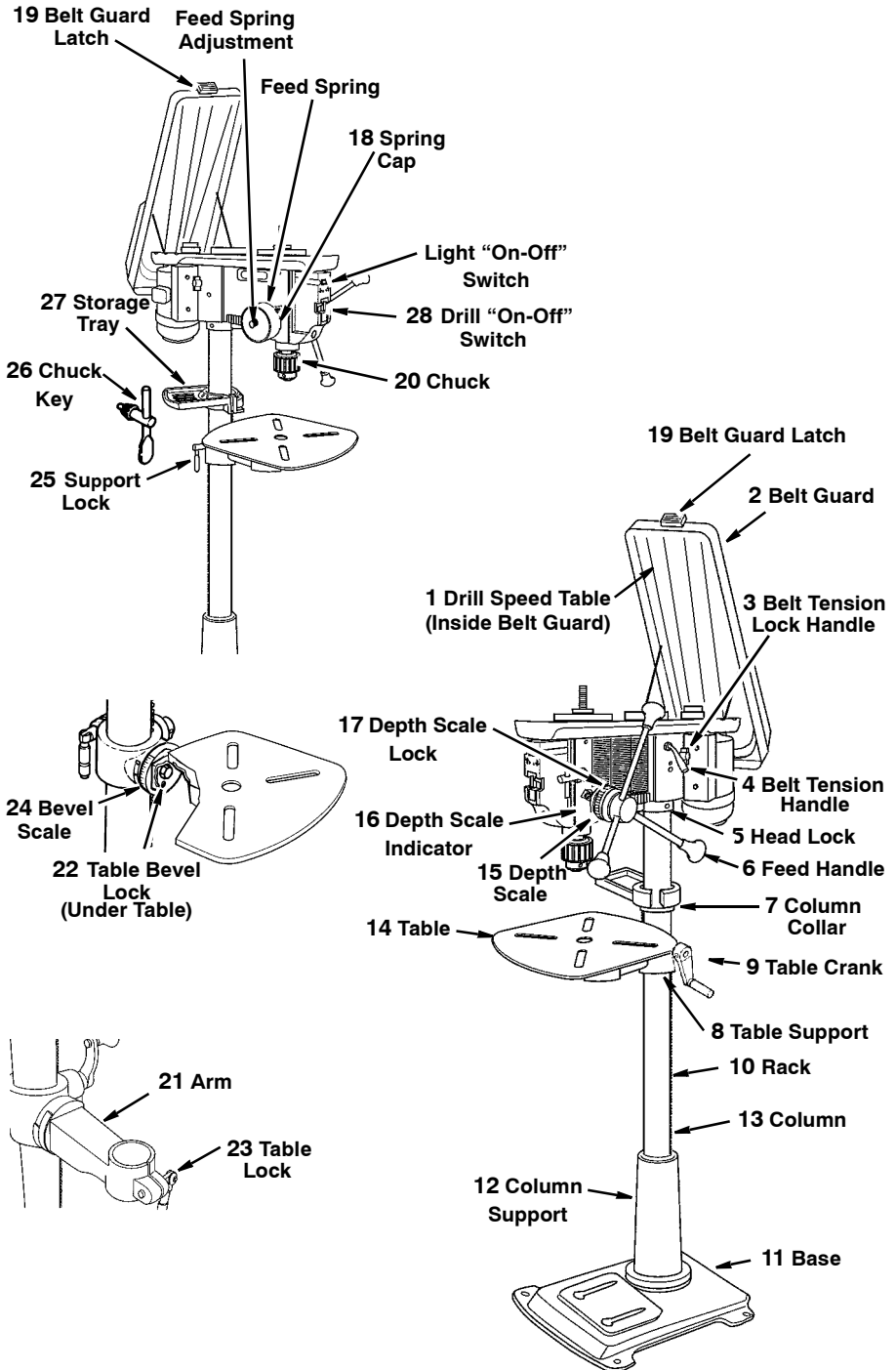





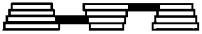

**Latch Adjusting Screws**

# Getting To Know Your Drill Press





## Spindle Speed in R.P.M.

300 	400 	450 	600 
650 	700 	1100 	1600 
1700 	1900 	2600 	3100 

1. **Drill Speed Table**...Drill Speed can be changed by placing the belt in any one of the stepped pulleys. The spindle speed chart, as shown above, lists belt positions for the various spindle speeds.
2. **Belt Guard**...Covers pulleys and belt during operation of drill press.
3. **Belt Tension Lock Handle**...Tightening handle locks motor bracket support to maintain correct belt distance and tension.
4. **Belt Tension Handle**...Turn handle counterclockwise to apply tension to belt, turn handle clockwise to release belt tension. Refer to section "Assembly-Installing and Tensioning Belt".
5. **Head Lock Set Screws**...Lock the head to the column. Always have them locked in place while operating the drill press.
6. **Feed Handle**...For moving the chuck up or down. One or two of the handles may be removed if necessary whenever the workpiece is of such unusual shape that it interferes with the handles.
7. **Column Collar**... Holds the rack to the column. Rack remains movable in collar to permit table support movements.
8. **Table Support**...Travels up and down on column. Supports arm and crank.
9. **Table Crank**...Turn clockwise to elevate table. Support lock must be released before operating crank.
10. **Rack**...Combines with gear mechanism to provide easy elevation of table by hand operated table crank.
11. **Base**...Supports drill press. For additional stability, holes are provided in base to bolt drill press to floor. (See "Additional Safety Instructions for Drill Presses".
12. **Column Support**...Supports column, guides rack, and provides mounting holes for column to base.
13. **Column**...Connects head, table and base on a one-piece tube for easy alignment and movement.
14. **Table**...Provides working surface to support workpiece.
15. **Depth Scale**...Shows depth of hole being drilled in inches and millimeters.
16. **Depth Scale Indicator**...Indicates drilling depth selected on depth scale.
17. **Depth Scale Lock**...Locks the depth scale to selected depth.
18. **Spring Asm.**...Provides means to adjust quill spring tension.
19. **Belt Guard Latch**...Press button to raise belt guard.
20. **Chuck**...Holds drill bit or other recommended accessory to perform desired operations.
21. **Arm**...Extends beyond table support for mounting aligning the table.
22. **Table Bevel Lock**...Locks the table in any position from 0°- 45°.
23. **Table Lock**...Table can be rotated in various positions and locked.
24. **Bevel Scale**...Shows degree table is tilted for bevel operations. Scale is mounted on table support, if it is to be used for quick reference where accuracy is not critical.

## Getting To Know Your Drill Press (continued)

- 25. Support Lock...** Tightening locks table support to column. Always have it locked in place while operating the drill press.
- 26. Chuck Key...** It is a self ejecting chuck key which will “pop” out of the chuck when you let go of it. This action is designed to help prevent throwing of the chuck key from the chuck when power is turned ON (I). Do not use any other key as a substitute, order a new one if damaged or lost.
- 27. Storage Tray...** Conveniently holds drill bits and other accessories.
- 28. I/O Switch...** Has locking feature. This feature is intended to prevent unauthorized and possible hazardous use by children and others. Insert key into switch.
- NOTE:** Key is made of yellow plastic.

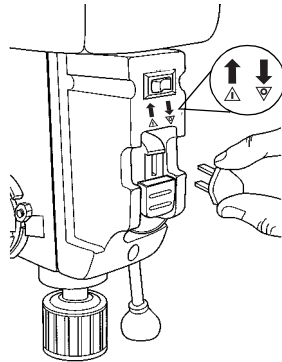
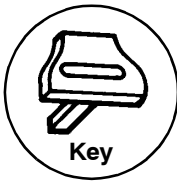

To turn drill ON (I), insert finger under switch lever and pull.

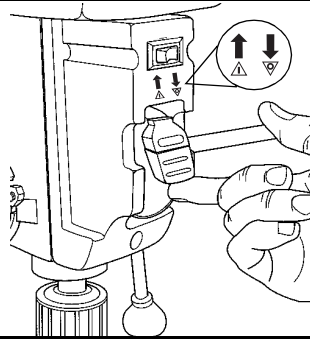

To turn drill OFF (O), push lever in.

**NOTE:** In an emergency: If the drill bit binds, stalls, stops or tends to tear the workpiece loose, you can quickly turn the drill off by hitting the switch with the palm of your hand.

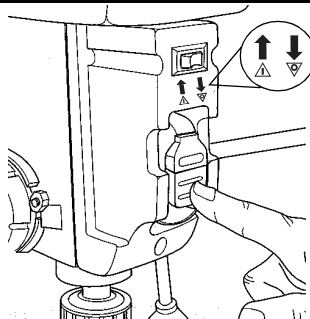

To lock switch in OFF (O) position, hold switch IN with one hand and remove key with other hand.

**⚠ WARNING:** For your own safety, always push the switch OFF (O) when drill press is not in use, remove key and keep it in a safe place, also, in the event of a power failure (all of your lights go out) or blown fuse or tripped circuit breaker, turn switch off, lock it and remove the key. This will prevent the drill press from starting up again when the power comes back on.

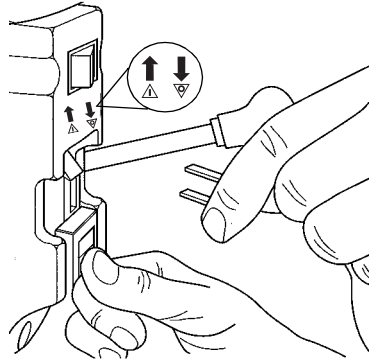

### Drilling to a Specific Depth

To drill a blind hole (not all the way through) to a given depth, proceed as follows.

1. Mark the depth of the hole on the workpiece.
2. Loosen the depth scale lock.
3. With the switch OFF (O), bring the drill bit down until the tip of lips of the bit are even with the mark.
4. Turn the depth scale counterclockwise until it stops moving.
5. Tighten the depth scale lock.
6. The drill bit will stop at this depth until the depth scale is readjusted.

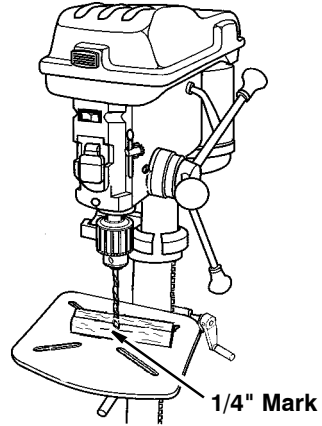

### Another Way - Depth Scale

1. With the power off, loosen the depth scale lock.
2. Place workpiece on table. Adjust table until the tip of the drill bit is just a little above the top of the workpiece, turn the depth scale counterclockwise to zero.
3. Turn the depth scale clockwise until the depth scale indicator points to the desired drilling depth on the depth scale.
4. Tighten the depth scale lock.
5. The chuck or drill will now be stopped after traveling downward the distance selected on the depth scale.

## Getting To Know Your Drill Press (continued)

### Locking Chuck at Desired Depth

1. With the switch off, loosen the depth scale lock.
2. Turn the feed handles until the chuck is at the desired depth. Hold feed handles at this position.
3. Turn the depth scale clockwise until it stops.
4. Tighten the depth scale lock.
5. The chuck will now be held at this depth when the feed handles are released.

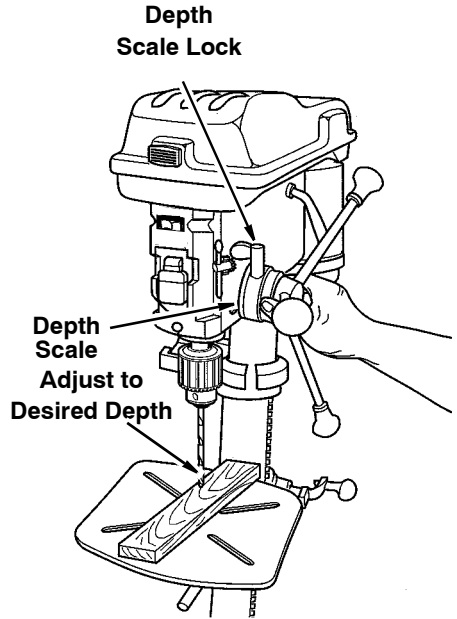

### Removing Chuck and Arbor

1. Open jaws of chuck as wide as they will go by turning chuck sleeve.
2. Using a downwards motion carefully tap on the chuck with a mallet while slowly turning the chuck with your other hand.

Make sure and hold onto the chuck to prevent it from dropping when it is released from the spindle nose.

**NOTE:** If chuck is difficult to remove, place dowel rod on top surface of chuck and tap dowel with hammer.

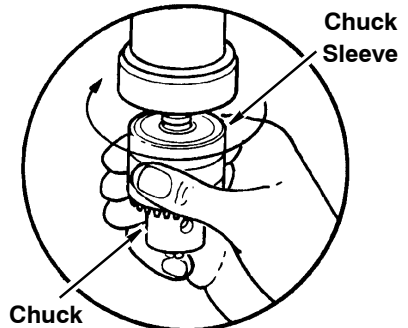
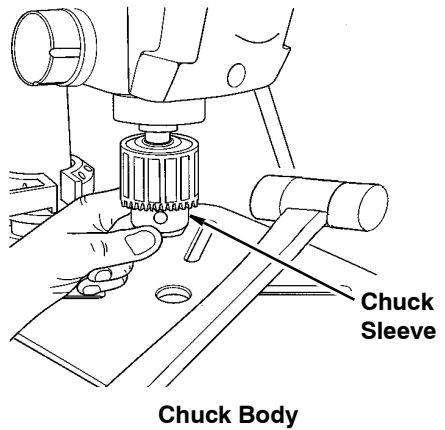

## Safety Instructions for Basic Drill Press Operation

Read the following instructions for operating your drill press to get the best results and to minimize the likelihood of personal injury.

**▲ WARNING:** For your own safety, always observe the safety precautions here and on pages 2 thru 6.

### Plan Ahead To Protect Your Eyes, Hands, Face and Ears

#### Dress for safety

- Do not wear loose clothing, gloves, neckties or jewelry (rings, wrist watches). They can get caught and draw you into moving parts.
- Wear nonslip footwear.
- Tie back long hair.
- Roll long sleeves above the elbow.
- Noise levels vary widely. To reduce the risk of possible hearing damage, wear ear plugs or muffs when using drill press for hours at a time.

#### Plan Your Work

- Don't force the tool. It will do the job better and safer at the rate for which it was designed.
- Use the right tool. Don't force tool or attachment to do a job it was not designed to do.
- If any part of your drill press is missing, malfunctioning, has been damaged or broken...such as the motor switch, or other operating control, a guard, safety device or the power cord, turn the drill press off and unplug it until the particular part is properly repaired or replaced.
- Never place your fingers in a position where they could contact the drill or other cutting tool if the workpiece should unexpectedly shift or your hand should slip.
- To reduce the risk of injury from parts thrown by the spring, follow instructions exactly as given and shown in adjusting spring tension of quill.

- To prevent the workpiece from being torn from your hands, spinning of the tool, shattering the tool or being thrown, always properly support your work so it won't shift or bind on the tool:
  - Always position backup material (use beneath the workpiece) to contact the left side of the column.
  - Whenever possible, position the workpiece to contact the left side of the column - If it is too short or the table is tilted, clamp solidly to the table. Use table slots or clamping ledge around the outside edge of the table.
  - When using a drill press vise, always fasten it to a table.
  - Never do any work "Freehand" (hand holding workpiece rather than supporting it on the table), except when polishing.
  - Securely lock head to column, table support to column and table to table support before operating drill press.
  - Never move the head or table while the tool is running.
  - Before starting the operation, jog the motor switch to make sure the drill or other cutting tool does not wobble or cause vibration.
  - If a workpiece overhangs the table such that it will fall or tip if not held, clamp it to the table or provide auxiliary support.
  - Use fixtures for unusual operations to adequately hold, guide and position workpiece.

## Getting To Know Your Drill Press (continued)

---

- Use the spindle speed recommended for the specific operation and workpiece material - check the inside of the belt guard for drilling information; for accessories, refer to the instructions provided with the accessories.
- Never climb on the drill press table, it could break or pull the entire drill press down on you.
- Turn the motor switch off and put away the switch key when leaving the drill press.
- To reduce the risk of injury from thrown work or tool contact, do not perform layout, assembly or setup work on the table while the cutting tool is rotating.
- Don't overreach. Keep proper footing and balance at all times.
- Maintain tools with care. Keep tools sharp and clean for best and safest performance. Follow instructions for lubricating and changing accessories.

---

## Use Only Accessories Designed For This Drill Press To Reduce the Risk of Serious Injury From Thrown Broken Parts Or Work Pieces

- When cutting large diameter holes:
  - Clamp the workpiece firmly to the table. Otherwise the cutting may grab and spin it at high speed.
  - Use only one piece, cup-type, hole cutters.
  - **Do not** use fly cutters or multi-part hole cutters as they can come apart or become unbalanced in use.
  - Keep speed below 1500 R.P.M.
- Drum sanders must **never** be operated on this drill press at a speed greater than 1800 R.P.M.
- Do not install or use any drill that exceeds 7" in length or extends 6" below the chuck jaws. They can suddenly bend outward or break.
- Do not use wire wheels, router bits, shaper cutters, circle (fly) cutters or rotary planers on this drill press.

---

## Basic Drill Press Operation

### Installing Drills

Insert drill into chuck far enough to obtain maximum gripping of the chuck jaws. The jaws are approximately 1" long. When using a small drill do not insert it so far that the jaws touch the flutes (spiral grooves) of the drill. Make sure that the drill is centered in the chuck before tightening the chuck with the key.

Tighten the drill sufficiently, so that it does not slip while drilling.

Turn the chuck key clockwise to tighten, counterclockwise to loosen.

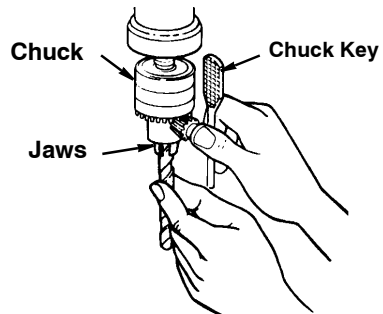

## Positioning Table and Workpiece

Lock the table to the column in a position so that the tip of the drill is just a little above the top of the workpiece.

Always place a piece of backup material (wood, plywood, etc.) on the table underneath the workpiece. This will prevent “splintering” or making a heavy burr on the underside on the workpiece as the drill breaks through. To keep the backup material from spinning out of control, it must contact the left side of the column, as illustrated.

**⚠ WARNING:** To prevent the workpiece or the backup material from being torn from your hand while drilling, position them against the left side of the column. If the workpiece or the backup material are not long enough to reach the column, clamp them to the table. Failure to do this could result in personal injury.

For small pieces that cannot be clamped to the table, use a drill press vise (not included).

**⚠ WARNING:** The vise must be clamped or bolted to the table to reduce the risk of injury from spinning work and vise or tool breakage.

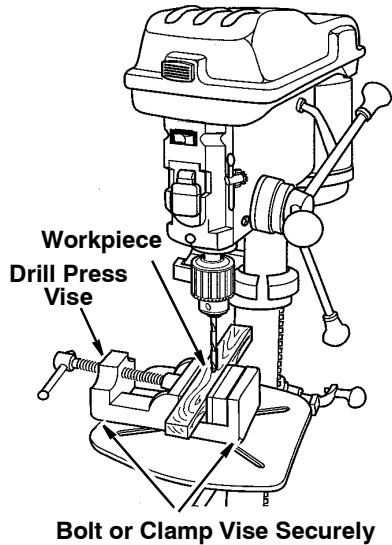
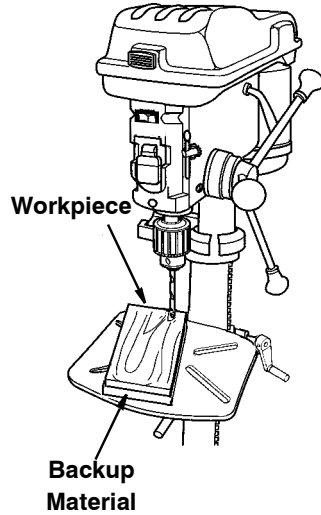

## Basic Drill Press Operation (continued)

---

### Tilting Table

To use the table in a bevel (tilted) position, loosen the set screw under table bevel lock with hex "L" wrench. Loosen bevel lock bolt with the 24mm flat wrench (included).

Tilt table to desired angle by reading bevel scale. Retighten bevel lock and set screw.

**⚠ WARNING:** To reduce the risk of injury from spinning work or tool breakage, always clamp workpiece and backup material securely to table before operating drill press with the table tilted.

To return table to original position: Loosen set screw and bevel lock, tilt table back to 0° on bevel scale and retighten set screw, then tighten bevel lock.

### Hole Location

Make a dent in the workpiece where you want the hole, using a center punch or a sharp nail.

Before turning the switch on, bring the drill down to the workpiece lining it up with the hole location.

### Feeding

Pull down on the feed handles with only enough effort to allow the drill to cut.

Feeding too slowly might cause the drill to burn. Feeding too rapidly might stop the motor, cause the belt or drill to slip, tear the workpiece loose or break the drill bit.

When drilling metal, it may be necessary to lubricate the tip of the drill with cutting oil or motor oil to prevent burning of the drill tip.

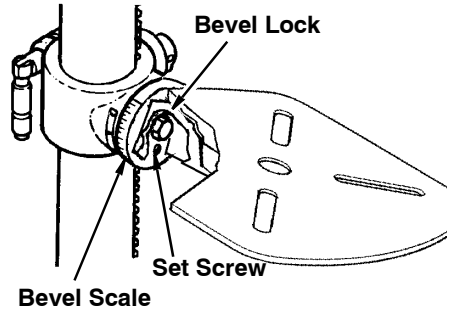



## Maintenance

### Maintenance

**⚠ WARNING:** For your own safety, turn switch OFF (O) and remove plug from power source outlet before maintaining or lubricating your drill press.

A coat of automotive type paste wax applied to the table and column will help to keep the surfaces clean.

**⚠ WARNING:** To reduce the risk of shock or fire hazard, if the power cord is worn or cut, or damaged in any way, have it replaced immediately.

### Lubrication

All of the ball bearings are packed with grease at the factory. They require no further lubrication.

Periodically lubricate the table elevation mechanism, the splines (grooves) in the spindle, and the rack (teeth of the quill). See "Getting to Know Your Drill Press".

## Wiring Diagram

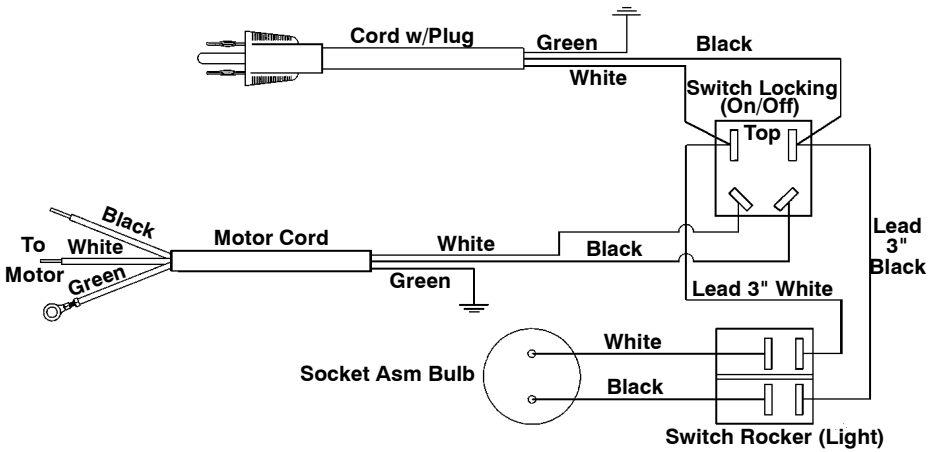

## Troubleshooting

**⚠ WARNING:** For your own safety, turn switch OFF (O) and always remove plug from power source outlet before troubleshooting.

Consult your Authorized Service Center if for any reason motor will not run.

Trouble	Probable Cause	Remedy
Noisy Operation	<ol style="list-style-type: none"> <li>1. Incorrect belt tension.</li> <li>2. Dry spindle.</li> <li>3. Loose spindle pulley</li> <li>4. Loose motor pulley</li> </ol>	<ol style="list-style-type: none"> <li>1. Adjust tension. See "Installing and Tensioning Belt" section.</li> <li>2. Lubricate spindle. See "Lubrication" section.</li> <li>3. Checking tightness of retaining nut on pulley, and tighten if necessary.</li> <li>4. Tighten set screws in pulleys.</li> </ol>

## Troubleshooting (continued)

Trouble	Probable Cause	Remedy
Drill bit burns	<ol style="list-style-type: none"> <li>1. Incorrect speed</li> <li>2. Chips not coming out of hole</li> <li>3. Dull drill bit</li> <li>4. Feeding too slow</li> <li>5. Not lubricated</li> </ol>	<ol style="list-style-type: none"> <li>1. Change speed. See “Getting to Know Your Drill Press” section.</li> <li>2. Retract drill bit frequently to clear chips</li> <li>3. Resharpener drill bit</li> <li>4. Feed fast enough, allow drill bit to cut</li> <li>5. Lubricate drill bit. See “Basic Drill Press Operation” section.</li> </ol>
Drill bit leads off, hole not round	<ol style="list-style-type: none"> <li>1. Hard grain in wood or lengths of cutting lips and/or angles not equal.</li> <li>2. Bent drill bit</li> </ol>	<ol style="list-style-type: none"> <li>1. Resharpener drill bit correctly</li> <li>2. Replace drill bit</li> </ol>
Wood splinters on underside	<ol style="list-style-type: none"> <li>1. No “backup material” under workpiece</li> </ol>	<ol style="list-style-type: none"> <li>1. Use “backup material”. See “Basic Drill Press Operation” section.</li> </ol>
Workpiece torn loose from hand	<ol style="list-style-type: none"> <li>1. Not supported or clamped properly</li> </ol>	<ol style="list-style-type: none"> <li>1. Support or clamp workpiece. See “Basic Drill Press Operation” section.</li> </ol>
Drill bit binds in workpiece	<ol style="list-style-type: none"> <li>1. Workpiece pinching drill bit or excessive feed pressure.</li> <li>2. Improper belt tension</li> </ol>	<ol style="list-style-type: none"> <li>1. Support or clamp workpiece. See “Basic Drill Press Operation” section.</li> <li>2. Adjust tension. See “Installing and Tensioning Belt” section.</li> </ol>
Excessive drill bit runout or wobble.	<ol style="list-style-type: none"> <li>1. Bent drill bit</li> <li>2. Worn spindle bearings</li> <li>3. Drill bit not properly installed in chuck</li> <li>4. Chuck not properly installed</li> </ol>	<ol style="list-style-type: none"> <li>1. Use a straight drill bit.</li> <li>2. Replace bearings</li> <li>3. Install drill bit properly. See “Basic Drill Press Operation” section.</li> <li>4. Install chuck properly, refer to “Assembly- Installing the Chuck”.</li> </ol>
Quill returns too slow or too fast	<ol style="list-style-type: none"> <li>1. Spring has improper tension</li> </ol>	<ol style="list-style-type: none"> <li>1. Adjust spring tension. See “Adjustments - Quill Return Spring” section.</li> </ol>
Chuck will not stay attached to spindle, it falls off when trying to install.	<ol style="list-style-type: none"> <li>1. Dirt, grease or oil on the tapered inside surface of chuck or on the spindles tapered surface.</li> </ol>	<ol style="list-style-type: none"> <li>1. Using a household detergent, clean the tapered surface of the chuck and spindle to remove all dirt, grease and oil.</li> </ol>
Chuck rotates but does not deliver sufficient torque to properly drill.	<ol style="list-style-type: none"> <li>1. Spindle pulley nut (part no. 821742) loose.</li> </ol>	<ol style="list-style-type: none"> <li>1. Turn nut <b>counterclockwise</b> to tighten. (The nut has left-hand threads.) See Repair Parts - Figure 1 for location of pulley nut.</li> </ol>

## Parts List for RIDGID 15" Drill Press Model No. DP15501 Figure 1

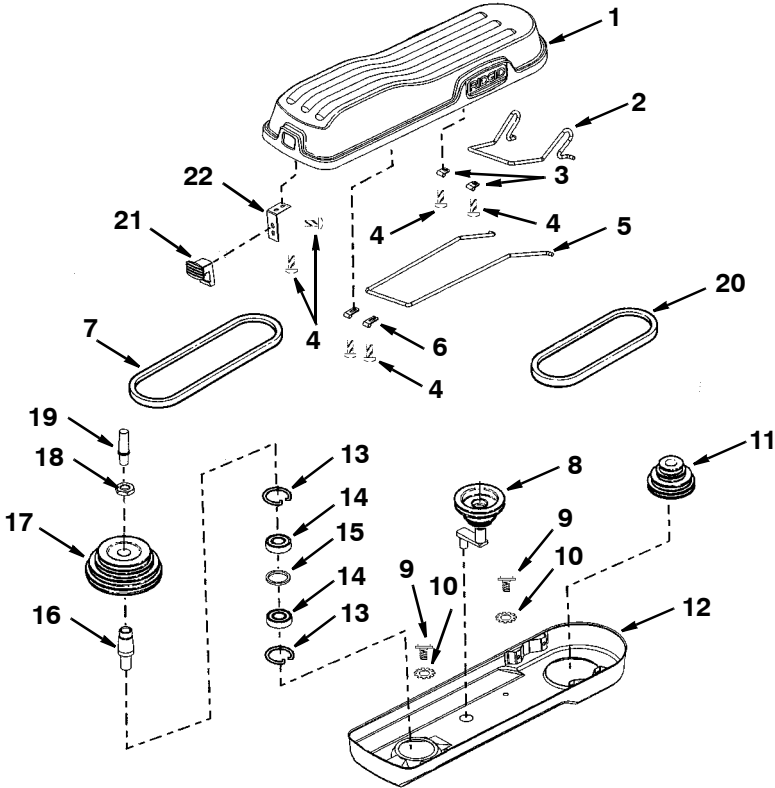

**Always order by Part Number - Not by Key Number**

Key No.	Part No.	Description	Key No.	Part No.	Description
1	829775	Guard Upper	11	828818	Pulley Asm - Motor
2	828814	Link - Rear	12	828816	Guard Lower
3	828812	Clamp - Rear Link	13	817537	Ring Retaining
4	828932	* Screw Pan Hd M5.5 x 1.8-12	14	817530	Bearing Ball 20 mm
5	828813	Link - Front	15	817536	Spacer
6	828811	Clamp - Front Link	16	821734	Insert Pulley
7	816439-4	Belt Poly V 27"	17	828849	Pulley Spindle
8	828919	Pulley Asm - Idler	18	821742	Nut Pulley
9	817358-1	* Screw Rd Hd Wash M6 x 1.0	19	829688	Cap Spindle
10	820241-5	* Lockwasher Ext M6	20	816439-5	Belt Poly V 25"
			21	828820	Latch
			22	828821	Spring Latch

\* Standard hardware item - may be purchased locally.

**Parts List for RIDGID 15" Drill Press  
Model No. DP15501  
Figure 2**

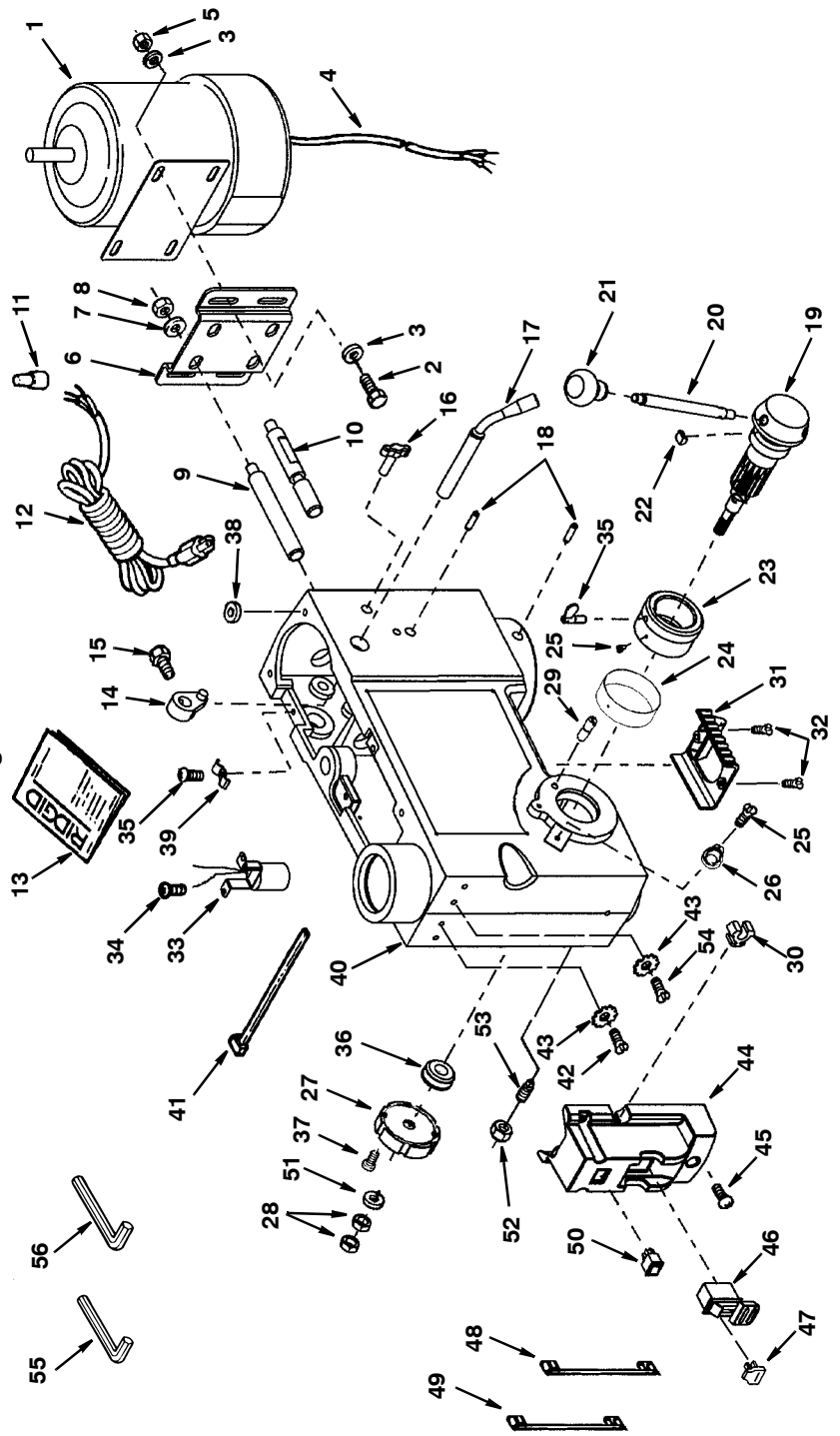

# Repair Parts

## Parts List for RIDGID 15" Drill Press Model No. DP15501 Figure 2

Always order by Part Number -- Not by Key Number

Key No.	Part No.	Description	Key No.	Part No.	Description
1	828929	* Motor	30	828877	Holder Key Chuck
2	820381-2	* Screw Hex Hd. M8 x 1.25-20	31	828963	Lens Assembly
3	821063-2	* Washer M8 x 16 x 1.6	32	820240-6	* Screw Pan Hd. M5 x 0.8-12
4	828940	Cord Motor	33	829595	Socket Bulb Asm.
5	824026-7	* Nut Hex M8 x 1.25	34	820244	* Screw Pan Hd. M6 x 1.0-12
6	817336-1	Mount Motor	35	817343	Lock Depth Screw
7	820383-8	* Lockwasher 12mm	36	828928	Bearing Pinion Shaft
8	820236-9	* Nut Hex M12 x 1.75	37	820378	Screw Soc Cap M4 x 0.7-10
9	817495	Support Motor Bracket	38	820294	Washer Foam
10	817516	Support Motor Bracket	39	829689	Clamp Cord
11	817330	Connector Wire	40	829826	Head Asm.
12	828941	Cord w/Plug	41	810506-3	Tie Wire
13	SP6490	Operator's Manual	42	829803	Screw Hex Hd. Gnd. M5 x 0.8
14	817317	Lever Adjusting	43	820241-4	Lockwasher Ext. M5
15	820381-4	* Screw Hex Hd. M8 x 1.25-16	44	828921	Box Switch Asm.
16	817320	Knob Motor Adjusting	45	820240	* Screw Pan Hd. M5 x 0.8-16
17	817494	Handle Belt Tension	46	829787	Switch Locking
18	821750	Screw Hex Soc. Set M10 x 1.5-12	47	826122	Key Switch
19	828904	Hub Asm.	48	829597	Lead 3" Black
20	826445	Rod	49	829597-1	Lead 3" White
21	826441	Knob	50	828923	Switch Rocker
22	817300	Guide Scale	51	829690	Washer 12mm ID Plain
23	829590	Ring Depth Stop	52	820236-8	* Nut Hex M10 x 1.5
24	828876	Scale Depth	53	817308	Screw Sl. Set FI Pt
25	816743-4	* Screw Pan Cr M4 x 0.7 x 8	54	820240-3	* Screw Pan Hd M5 x 0.8-6
26	826057	Pointer	55	813317-6	Wrench Hex "L" 3mm
27	828880	Spring Asm.	56	813317-8	Wrench Hex "L" 5mm
28	821738-3	* Nut Hex M12 x 1.5-8			
29	828917	Pin Stop			

\* Standard hardware item - may be purchased locally.

• Any attempt to repair this motor may create a hazard unless repair is done by a qualified service technician.

Repair service is available at your nearest Authorized Service Center.

**Parts List for RIDGID 15" Drill Press  
Model No. DP15501**

**Figure 3**

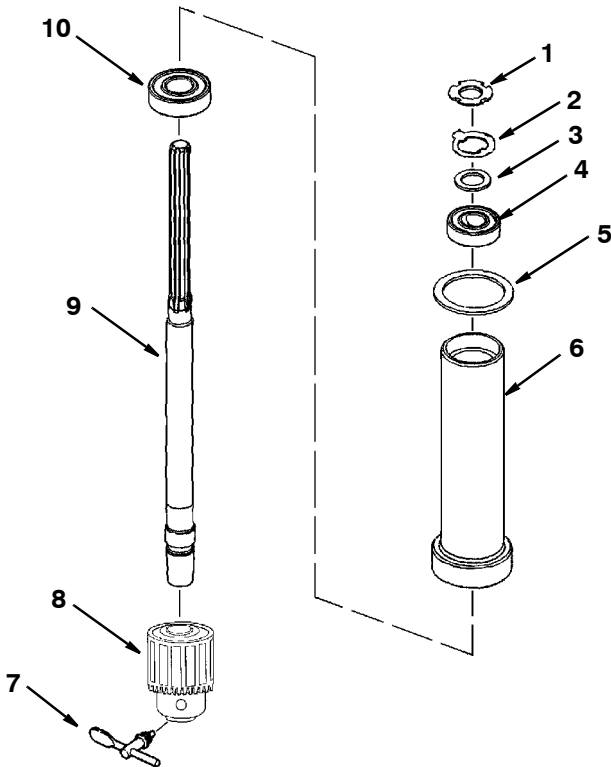

**Always order by Part Number - Not by Key Number**

Key No.	Part No.	Description
1	817309	Lock Nut M17 x 1.0
2	817310	Ring Locking
3	817311	Washer
4	813480	Bearing Ball 17mm
5	817535	Gasket Quill

Key No.	Part No.	Description
6	828875	Tube Quill
7	817339	Key Chuck
8	817340	Chuck
9	828908	Spindle
10	817529	Bearing Ball

# Repair Parts

## Parts List for RDIGID 15" Drill Press Model No. DP15501 Figure 4

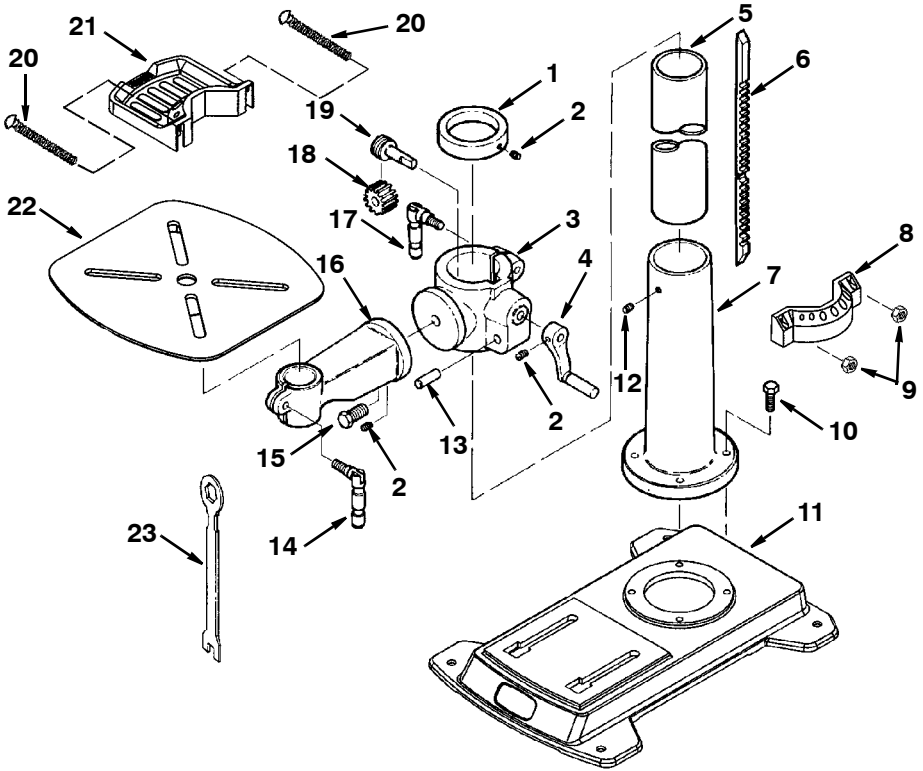

Key No.	Part No.	Description	Key No.	Part No.	Description
1	817478	Collar Rack	12	821750	* Screw Hex Soc. Set M10 x 1.5-12
2	820245	* Screw Hex Soc. Set M6 x 1.0-10	13	817288	Pin Gear
3	821861-2	Support Table w/Indicator	14	817290-3	Clamp Table
4	826439	Crank (Includes Set Screw)	15	821732	Screw Hex Hd. M16 x 2.0-35
5	821880	Tube Column	16	817777-3	Arm Table w/Scale
6	828927	Rack	17	817294-2	Clamp Column
7	821881-1	Support Column	18	817350	Gear Helical
8	828870	Tray, Back	19	817349	Worm Elevation
9	813164-6	Nut Hex M5	20	10251002	* Screw Pan Hd Cr M5 x 0.8-60
10	821754	* Screw Hex Hd. M10 x 1.5-40	21	828871	Tray, Front
11	828961	Base	22	828903	Table
			23	826438	Wrench Hex 24mm

\* Standard hardware item - may be purchased locally.

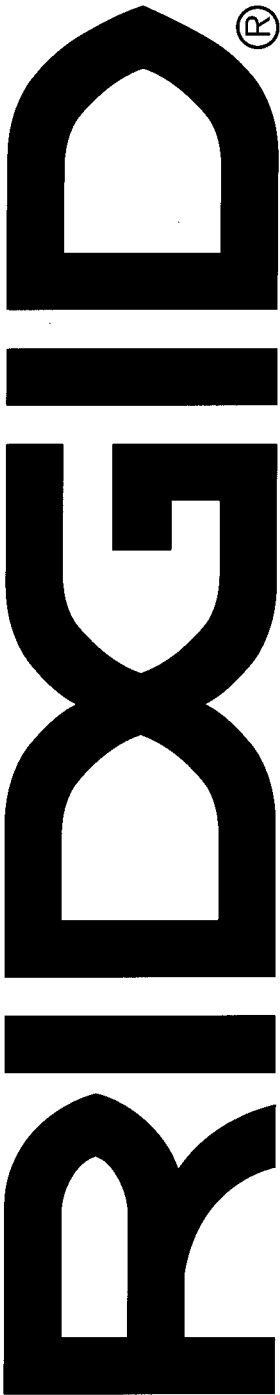

One World Technologies, Inc.  
Hwy. 8  
Pickens, SC 29671

**RIDGID® HAND HELD AND STATIONARY POWER TOOL  
LIMITED THREE YEAR WARRANTY AND 90-DAY  
SATISFACTION GUARANTEE POLICY**

This product is manufactured by One World Technologies, Inc., under a trademark license from Ridgid, Inc. All warranty communications should be directed to One World Technologies, Inc., attn: RIDGID handheld and stationary power tool technical service at (toll free) 1-866-539-1710.

**90-DAY SATISFACTION GUARANTEE POLICY**

During the first 90 days after the date of purchase, if you are dissatisfied with the performance of this RIDGID tool for any reason you may return the tool to the dealer from which it was purchased for a full refund or exchange. To receive a replacement tool you must present proof of purchase and return all original equipment packaged with the original product. The replacement tool will be covered by the limited warranty for the balance of the three year warranty period.

**WHAT IS COVERED UNDER THE LIMITED THREE YEAR WARRANTY**

This warranty covers all defects in workmanship or materials in this RIDGID tool for the three year period from the date of purchase. This warranty is specific to this tool. Warranties for other RIDGID products may vary.

**HOW TO OBTAIN SERVICE**

To obtain service for this RIDGID tool you must return it, freight prepaid, to an authorized RIDGID service center for hand held and stationary power tools. You may obtain the location of the authorized service center nearest you by calling (toll free) 1-866-539-1710 or by logging on to the RIDGID website at [www.ridgid.com](http://www.ridgid.com). When requesting warranty service, you must present the proof of purchase documentation, which includes a date of purchase. The authorized service center will repair any faulty workmanship, and either repair or replace any defective part, at our option at no charge to you.

**WHAT IS NOT COVERED**

This warranty applies only to the original purchaser at retail and may not be transferred. This warranty only covers defects arising under normal usage and does not cover any malfunction, failure or defect resulting from misuse, abuse, neglect, alteration, modification or repair by other than an authorized service center for RIDGID branded hand held and stationary power tools. RIDGID, INC. AND ONE WORLD TECHNOLOGIES, INC. MAKE NO WARRANTIES, REPRESENTATIONS OR PROMISES AS TO THE QUALITY OR PERFORMANCE OF ITS POWER TOOLS OTHER THAN THOSE SPECIFICALLY STATED IN THIS WARRANTY.

**ADDITIONAL LIMITATIONS**

To the extent permitted by applicable law, all implied warranties, including warranties of MERCHANTABILITY or FITNESS FOR A PARTICULAR PURPOSE, are disclaimed. Any implied warranties, including warranties of merchantability or fitness for a particular purpose, that cannot be disclaimed under state law are limited to three years from the date of purchase. One World Technologies, Inc. is not responsible for direct, indirect, incidental or consequential damages. Some states do not allow limitations on how long an implied warranty lasts and/or do not allow the exclusion or limitation of incidental or consequential damages, so the above limitations may not apply to you. This warranty gives you specific legal rights, and you may also have other rights which vary from state to state.

**Stock No. DP1550      Model No. DP15501**  
**Serial No. \_\_\_\_\_** Model and serial numbers may be found at the left side of the head. You should record serial number in a safe place for future use.

**QUESTIONS OR COMMENTS?**

**CALL 1-866-539-1710**

**[www.ridgid.com](http://www.ridgid.com)**

**Please have your Model Number and Serial Number on hand when calling.**