

# OPERATOR'S MANUAL

1/2 in. (13 mm)

Spade Handle Drill

R7120

Single Speed/Reversible

Double Insulated

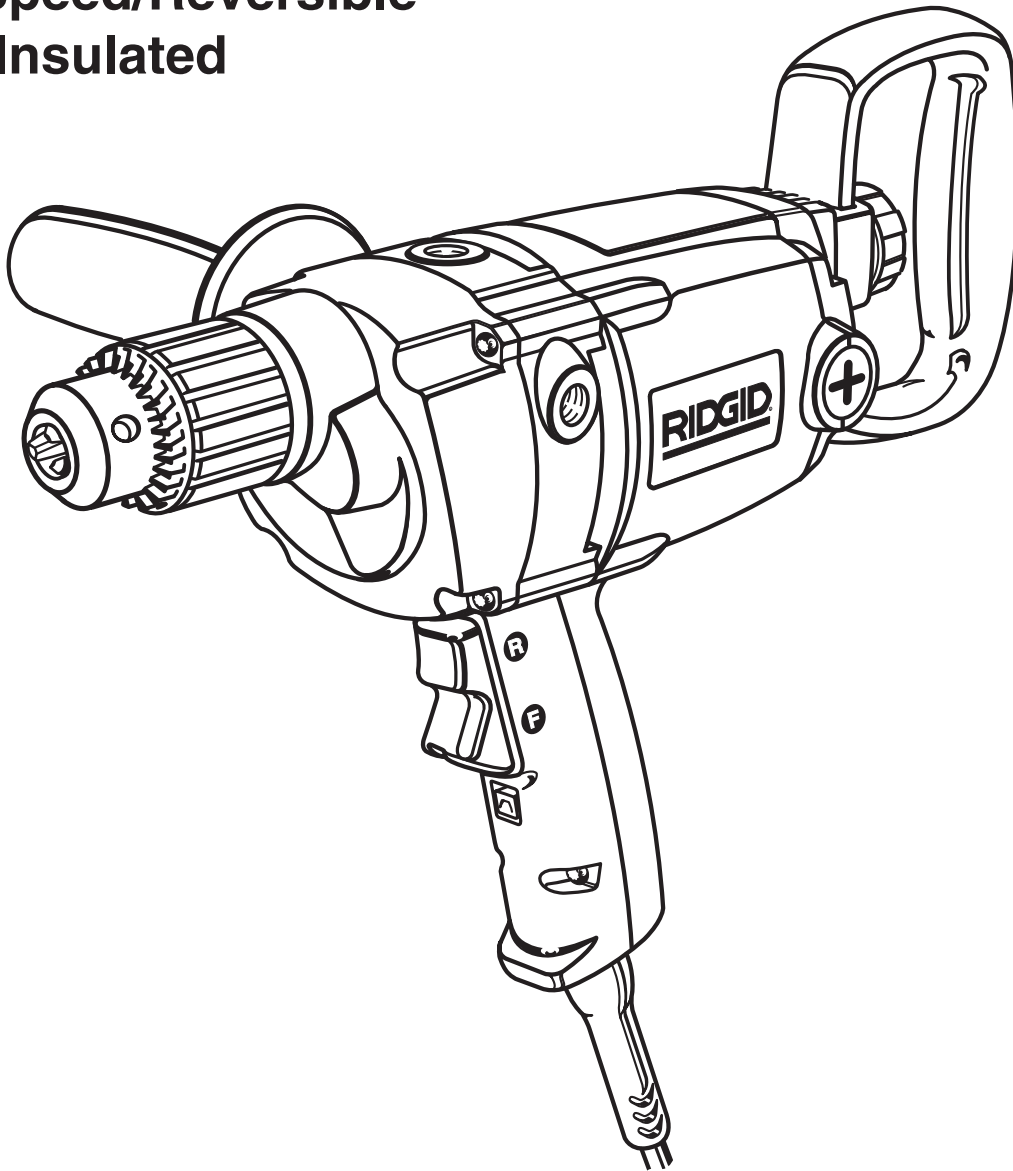

This new drill has been engineered and manufactured to our high standard for dependability, ease of operation and operator safety. When properly cared for, the drill will give you years of rugged, trouble-free performance.

---

**⚠ WARNING**

To reduce the risk of injury, the user must read and understand the operator's manual before using this product.

---

Thank you for buying a RIDGID product.

**SAVE THIS MANUAL FOR FUTURE REFERENCE**

# TABLE OF CONTENTS

---

■ Introduction .....	2
■ General Safety Rules .....	3-4
■ Specific Safety Rules .....	4
■ Symbols .....	5
■ Electrical .....	6
■ Features .....	7-8
■ Specifications .....	7
■ Unpacking .....	8
■ Assembly .....	9-10
■ Operation .....	11-12
■ Applications .....	11
■ Maintenance .....	13-15
■ Accessories .....	15
■ Warranty .....	17
■ Customer Service Information .....	18

## INTRODUCTION

---

The spade handle drill has many features for making the use of this product more pleasant and enjoyable. Safety, performance, and dependability have been given top priority in the design of this product making it easy to maintain and operate.

---

### **WARNING:**

Do not attempt to use this product until you thoroughly read and completely understand the operator's manual. Pay close attention to the safety rules, including Dangers, Warnings, and Cautions. If you use your product properly and only as intended, you will enjoy years of safe, reliable service.

---



**Look for this symbol to point out important safety precautions. It means attention!!! Your safety is involved.**



---

### **WARNING:**

The operation of any tool can result in foreign objects being thrown into your eyes, which can result in severe eye damage. Before beginning operation, always wear safety goggles or safety glasses with side shields and a full face shield when needed. We recommend Wide Vision Safety Mask for use over eyeglasses or standard safety glasses with side shields. Always wear eye protection which is marked to comply with ANSI Z87.1.

---

# GENERAL SAFETY RULES

---

## WARNING:

Read and understand all instructions. Failure to follow all instructions listed below, may result in electric shock, fire and/or serious personal injury.

---

## SAVE THESE INSTRUCTIONS

### WORK AREA

- **Keep your work area clean and well lit.** Cluttered benches and dark areas invite accidents.
- **Do not operate power tools in explosive atmospheres, such as in the presence of flammable liquids, gases, or dust.** Power tools create sparks which may ignite the dust or fumes.
- **Keep bystanders, children, and visitors away while operating a power tool.** Distractions can cause you to lose control.

### ELECTRICAL SAFETY

- **Double insulated tools are equipped with a polarized plug (one blade is wider than the other). This plug will fit in a polarized outlet only one way. If the plug does not fit fully in the outlet, reverse the plug. If it still does not fit, contact a qualified electrician to install a polarized outlet. Do not change the plug in any way.** Double insulation  eliminates the need for the three-wire grounded power cord and grounded power supply system.
- **Avoid body contact with grounded surfaces, such as pipes, radiators, ranges, and refrigerators.** There is an increased risk of electric shock if your body is grounded.
- **Don't expose power tools to rain or wet conditions.** Water entering a power tool will increase the risk of electric shock.
- **Do not abuse the cord. Never use the cord to carry the tools or pull the plug from an outlet. Keep cord away from heat, oil, sharp edges, or moving parts. Replace damaged cords immediately.** Damaged cords increase the risk of electric shock.
- **When operating a power tool outside, use an outdoor extension cord marked "W-A" or "W".** These cords are rated for outdoor use and reduce the risk of electric shock.

### PERSONAL SAFETY

- **Stay alert, watch what you are doing and use common sense when operating a power tool. Do not use tool while tired or under the influence of drugs, alcohol, or medication.** A moment of inattention while operating power tools may result in serious personal injury.
- **Dress properly. Do not wear loose clothing or jewelry. Contain long hair. Keep your hair, clothing, and gloves away from moving parts.** Loose clothes, jewelry, or long hair can be caught in moving parts.

- **Avoid accidental starting. Be sure switch is off before plugging in.** Carrying tools with your finger on the switch or plugging in tools that have the switch on, invites accidents.
- **Remove adjusting keys or wrenches before turning the tool on.** A wrench or a key that is left attached to a rotating part of the tool may result in personal injury.
- **Do not overreach. Keep proper footing and balance at all times.** Proper footing and balance enables better control of the tool in unexpected situations.
- **Use safety equipment. Always wear eye protection.** Dust mask, nonskid safety shoes, hard hat, or hearing protection must be used for appropriate conditions.
- **Do not use on a ladder or unstable support.**
- **Loose clothes, jewelry, or long hair can be drawn into air vents.**

### TOOL USE AND CARE

- **Use clamps or other practical way to secure and support the workpiece to a stable platform.** Holding the work by hand or against your body is unstable and may lead to loss of control.
- **Do not force tool. Use the correct tool for your application.** The correct tool will do the job better and safer at the rate for which it is designed.
- **Do not use tool if switch does not turn it on or off.** Any tool that cannot be controlled with the switch is dangerous and must be repaired.
- **Disconnect the plug from power source before making any adjustments, changing accessories, or storing the tool.** Such preventive safety measures reduce the risk of starting the tool accidentally.
- **Store idle tools out of the reach of children and other untrained persons.** Tools are dangerous in the hands of untrained users.
- **Maintain tools with care. Keep cutting tools sharp and clean.** Properly maintained tools with sharp cutting edges are less likely to bind and are easier to control.
- **Check for misalignment or binding of moving parts, breakage of parts, and any other condition that may affect the tool's operation. If damaged, have the tool serviced before using.** Many accidents are caused by poorly maintained tools.
- **Use only accessories that are recommended by the manufacturer for your model.** Accessories that may be suitable for one tool, may become hazardous when used on another tool.
- **Keep the tool and its handle dry, clean and free from oil and grease.** Always use a clean cloth when cleaning. Never use brake fluids, gasoline, petroleum-based products, or any strong solvents to clean your tool. Following this rule will reduce the risk of loss of control and deterioration of the enclosure plastic.

# GENERAL SAFETY RULES

---

## SERVICE

- **Tool service must be performed only by qualified repair personnel.** Service or maintenance performed by unqualified personnel could result in a risk of injury.

## SPECIFIC SAFETY RULES

---

### ADDITIONAL SAFETY RULES

- **Hold tool by insulated gripping surfaces when performing an operation where the cutting tools may contact hidden wiring or its own cord.** Contact with a “live” wire will make exposed metal parts of the cutting tool “live” and shock the operator.
- **Know your power tool. Read operator’s manual carefully. Learn its applications and limitations, as well as the specific potential hazards related to this tool.** Following this rule will reduce the risk of electric shock, fire, or serious injury.
- **Always wear safety glasses. Everyday eyeglasses have only impact-resistant lenses; they are NOT safety glasses.** Following this rule will reduce the risk of serious personal injury.
- **Protect your lungs. Wear a face or dust mask if the operation is dusty.** Following this rule will reduce the risk of serious personal injury.
- **Protect your hearing. Wear hearing protection during extended periods of operation.** Following this rule will reduce the risk of serious personal injury.
- **Inspect tool cords periodically and, if damaged, have repaired at your nearest Authorized Service Center. Constantly stay aware of cord location.** Following this rule will reduce the risk of electric shock or fire.
- **Check damaged parts. Before further use of the tool, a guard or other part that is damaged should be carefully checked to determine that it will operate properly and perform its intended function. Check for alignment of moving parts, binding of moving parts, breakage of parts, mounting, and any other conditions that may affect its operation. A guard or other part that is damaged should be properly repaired or replaced by an authorized service center.** Following this rule will reduce the risk of shock, fire, or serious injury.
- **Do not abuse cord. Never carry the tool by the cord or yank it to disconnect it from the receptacle. Keep cord away from heat, oil, and sharp edges.** Following this rule will reduce the risk of electric shock or fire.

- **When servicing a tool, use only identical replacement parts. Follow instructions in the Maintenance section of this manual.** Use of unauthorized parts or failure to follow Maintenance Instructions may create a risk of electric shock or injury.

- **Make sure your extension cord is in good condition. When using an extension cord, be sure to use one heavy enough to carry the current your product will draw. A wire gage size (A.W.G.) of at least 14 is recommended for an extension cord 50 feet or less in length. A cord exceeding 100 feet is not recommended. If in doubt, use the next heavier gage. The smaller the gage number, the heavier the cord.** An undersized cord will cause a drop in line voltage resulting in loss of power and overheating.
- **Inspect for and remove all nails from lumber before using this tool.** Following this rule will reduce the risk of serious personal injury.
- **Drugs, alcohol, medication. Do not operate tool while under the influence of drugs, alcohol, or any medication.** Following this rule will reduce the risk of electric shock, fire, or serious personal injury.
- **Save these instructions.** Refer to them frequently and use them to instruct others who may use this tool. If you loan someone this tool, loan them these instructions also.

---

### **WARNING:**

Some dust created by power sanding, sawing, grinding, drilling, and other construction activities contains chemicals known to cause cancer, birth defects or other reproductive harm. Some examples of these chemicals are:





- lead from lead-based paints,
- crystalline silica from bricks and cement and other masonry products, and
- arsenic and chromium from chemically-treated lumber.

Your risk from these exposures varies, depending on how often you do this type of work. To reduce your exposure to these chemicals: work in a well ventilated area, and work with approved safety equipment, such as those dust masks that are specially designed to filter out microscopic particles.

---

# SYMBOLS

**Important:** Some of the following symbols may be used on your tool. Please study them and learn their meaning. Proper interpretation of these symbols will allow you to operate the tool better and safer.

SYMBOL	NAME	DESIGNATION/EXPLANATION
V	Volts	Voltage
A	Amperes	Current
Hz	Hertz	Frequency (cycles per second)
W	Watt	Power
min	Minutes	Time
~	Alternating Current	Type of current
$n_0$	No Load Speed	Rotational speed, at no load
	Class II Construction	Double-insulated construction
.../min	Per Minute	Revolutions, strokes, surface speed, orbits etc., per minute
	Safety Alert	Precautions that involve your safety
	Eye Protection	Always wear safety goggles or safety glasses with side shields and a full face shield when operating this product.
	Wet Conditions Alert	Do not expose to rain or use in damp locations.

The purpose of safety symbols is to attract your attention to possible dangers. The safety symbols, and the explanations with them, deserve your careful attention and understanding. The safety warnings do not by themselves eliminate any danger. The instructions or warnings they give are not substitutes for proper accident prevention measures.



**DANGER:** Indicates an imminently hazardous situation, which, if not avoided, will result in death or serious injury.



**WARNING:** Indicates a potentially hazardous situation, which, if not avoided, could result in death or serious injury.



**CAUTION:** Indicates a potentially hazardous situation, which, if not avoided, may result in minor or moderate injury. It may also be used to alert against unsafe practices that may cause property damage.

**Important:** Advises you of important information or instructions vital to the operation or maintenance of the equipment.

**Note:** Advises you of additional information concerning the operation or maintenance of the equipment.

# ELECTRICAL

---

## DOUBLE INSULATION

Double insulation is a concept in safety in electric power tools, which eliminates the need for the usual three-wire grounded power cord. All exposed metal parts are isolated from the internal metal motor components with protecting insulation. Double insulated tools do not need to be grounded.

---

### **⚠ WARNING:**

The double insulated system is intended to protect the user from shock resulting from a break in the tool's internal wiring. Observe all normal safety precautions to avoid electrical shock.

---

**Important:** Servicing of a tool with double insulation requires extreme care and knowledge of the system and should be performed only by a qualified service technician. For service, we suggest you return the tool to your nearest authorized service center for repair. Always use original factory replacement parts when servicing.

## ELECTRICAL CONNECTION

The drill has a precision-built electric motor. It should be connected to a power supply that is 120 volts, 60 Hz, AC only (normal household current). Do not operate this tool on direct current (DC). A substantial voltage drop will cause a loss of power and the motor will overheat. If your tool does not operate when plugged into an outlet, double-check the power supply.

## EXTENSION CORDS

When using a power tool at a considerable distance from a power source, be sure to use an extension cord that has the capacity to handle the current the tool will draw. An undersized cord will cause a drop in line voltage, resulting in overheating and loss of power. Use the chart to determine the minimum wire size required in an extension cord. Only round jacketed cords listed by Underwriter's Laboratories (UL) should be used.

When working outdoors with a tool, use an extension cord that is designed for outside use. This type of cord is designated with "WA" on the cord's jacket.

Before using any extension cord, inspect it for loose or exposed wires and cut or worn insulation.

\*\*Ampere rating (on tool faceplate)

0-2.0    2.1-3.4    3.5-5.0    5.1-7.0    7.1-12.0    12.1-16.0

<b>Cord Length</b>	<b>Wire Size (A.W.G.)</b>					
25'	16	16	16	16	14	14
50'	16	16	16	14	14	12
100'	16	16	14	12	10	—

\*\*Used on 12 gauge - 20 amp circuit.

---

### **⚠ WARNING:**

Keep the extension cord clear of the working area. Position the cord so that it will not get caught on lumber, tools or other obstructions while you are working with a power tool. Failure to do so can result in serious personal injury.

---

### **⚠ WARNING:**

Check extension cords before each use. If damaged replace immediately. Never use tool with a damaged cord since touching the damaged area could cause electrical shock resulting in serious injury.

---

# FEATURES

---

## SPECIFICATIONS

Chuck .....	1/2 in. (13mm), Keyed
Switch .....	Single Speed/Reversible
No Load Speed .....	500/min.
Input .....	120 Volts, 60 Hz, AC only, 7.5 Amps
Net Weight .....	8.1 lbs. (3.7 kg)

Before using this tool, familiarize yourself with all operating features and safety requirements. However, do not let familiarity with the tool make you careless.

This new drill is equipped with the following features. See *Figure 1*.

### SINGLE SPEED REVERSIBLE SWITCH

This drill has a single speed rocker-type switch. The switch is reversible for changing the direction of rotation.

### LOCK-ON BUTTON

This tool is equipped with a lock-on feature for continuous drilling.

### AUXILIARY HANDLE

This drill is equipped with a three-position auxiliary handle for ease of operation and to prevent loss of control.

### SPADE HANDLE

This drill is equipped with a two-position rear spade handle for control tailored to the project.

### POWER CORD

This tool has a 12 foot power cord with a built-in cord wrap.

### EXTERNALLY ACCESSIBLE BRUSHES

Externally accessible brushes extend the life of the machine.

### LIGHTED PLUG

The lighted plug helps to easily identify live tools.

# FEATURES

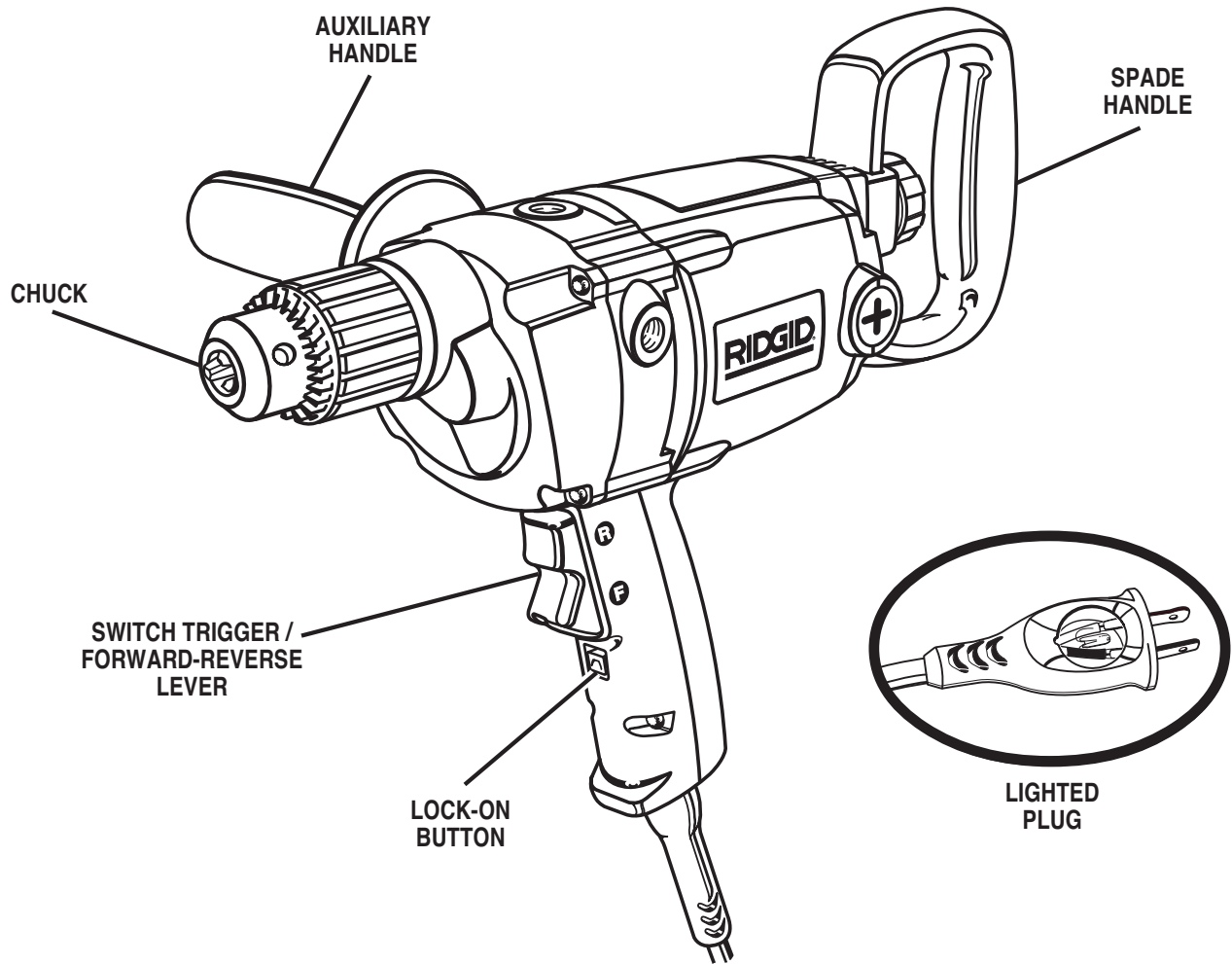

Fig. 1

# UNPACKING

## INSTRUCTIONS

When unpacking the drill:

- Carefully remove the tool and accessories from the box.
- Make sure that all items listed in the packing list are included.
- Inspect the tool carefully to make sure no breakage or damage occurred during shipping.
- Do not discard the packing material until you have carefully inspected and satisfactorily operated the tool.
- If any parts are damaged or missing, please call 1-866-539-1710 for assistance.

## PACKING LIST

- 1/2 in. (13 mm) Single Speed Reversible Drill
- Spade Handle
- Auxiliary Handle
- Chuck Key
- Key strap
- Operator's Manual

### **⚠ WARNING:**

If any parts are missing do not operate the tool until the missing parts are replaced. Failure to do so could result in possible serious personal injury.

### **⚠ WARNING:**

The tool should never be connected to a power supply when you are assembling parts, making adjustments, cleaning, performing maintenance, or when the tool is not in use. Disconnecting the tool will prevent accidental starting that could cause injury.



# ASSEMBLY

## **⚠ WARNING:**

The tool should never be connected to a power supply when you are assembling parts, making adjustments, cleaning, performing maintenance, or when the tool is not in use. Disconnecting the tool will prevent accidental starting that could cause serious injury.

## **INSTALLING AUXILIARY HANDLE**

See Figure 2.

An auxiliary handle is packed with the drill for ease of operation and to help prevent loss of control. The auxiliary handle may be installed at three different positions on the drill body.

To install the auxiliary handle:

- Insert the threaded end of the handle into one of the three positions on the drill as shown in figure 2.
- Tighten the auxiliary handle at the desired angle by turning the handle clockwise.

To prevent thread damage and possible loss of control, the auxiliary handle should be checked periodically for tightness. Do not operate the drill with the handle loose.

## **INSTALLING SPADE HANDLE**

See Figure 3.

A two-position spade handle is packed with the drill for ease of operation and to help prevent loss of control.

To install the spade handle:

- Place handle either vertically or horizontally on the mounting boss, located on the rear end of the drill.
- Turn the cap screw clockwise and tighten securely. Do not over tighten.

To prevent thread damage and possible loss of control, the spade handle should be checked periodically for tightness. Do not operate the drill with the handle loose.

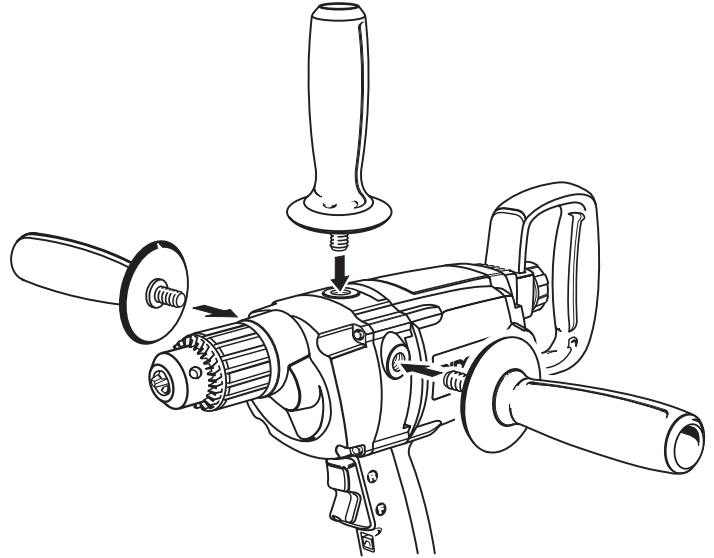

Fig. 2

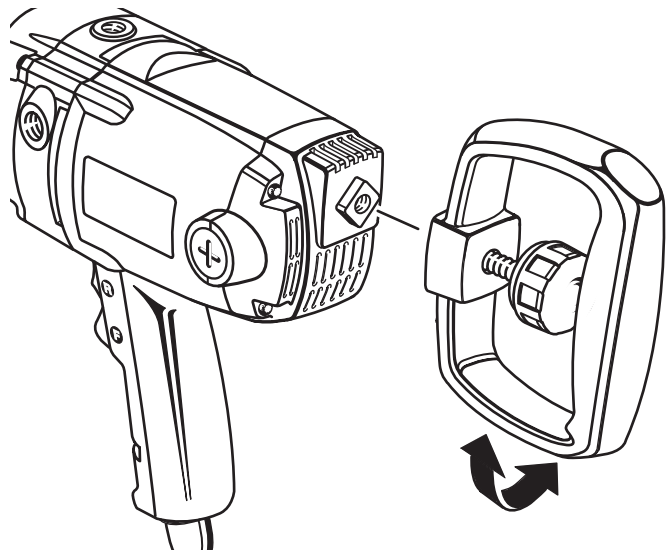

Fig. 3

# ASSEMBLY

## TO INSTALL BITS

See Figure 4.

- Unplug the drill.
- Insert the chuck key and twist counterclockwise as shown in figure 4.
- Insert the drill bit into the chuck the full length of the jaws.

### **⚠ WARNING:**

Do not insert drill bit into chuck jaws and tighten as shown in figure 5. This could cause the drill bit to be thrown from the drill resulting in possible serious personal injury or damage to the chuck.

- Tighten the chuck jaws securely on the drill bit, using the chuck key provided. Do not use a wrench to tighten or loosen the chuck jaws. For best performance, repeat this for the remaining two key holes.
- Remove the chuck key and return it to the storage area.

## TO REMOVE BITS

- Unplug the drill.
- Loosen the chuck jaws using the chuck key provided. See "To Install Bits."
- Remove the drill bit from the chuck jaws.
- Remove the chuck key and return it to the storage area.

## CHUCK KEY

A chuck key has been provided for use when installing or removing bits. It is also used when removing the chuck. (See chuck removal section.)

When not in use, the chuck key can be placed in the key strap.

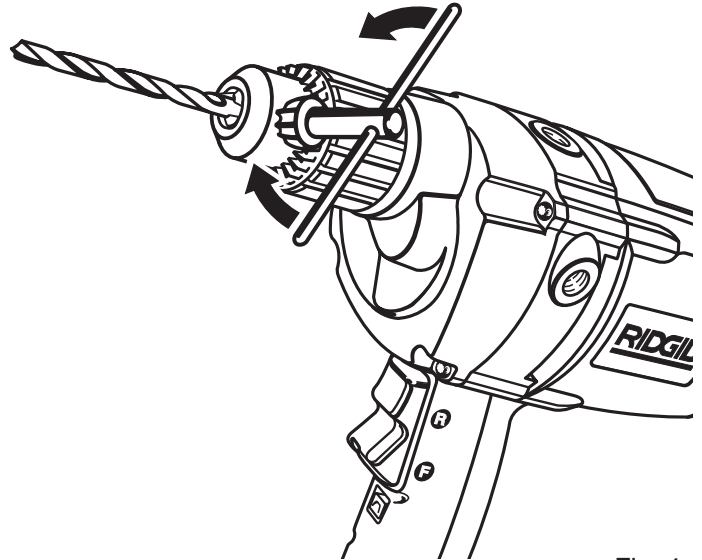

Fig. 4

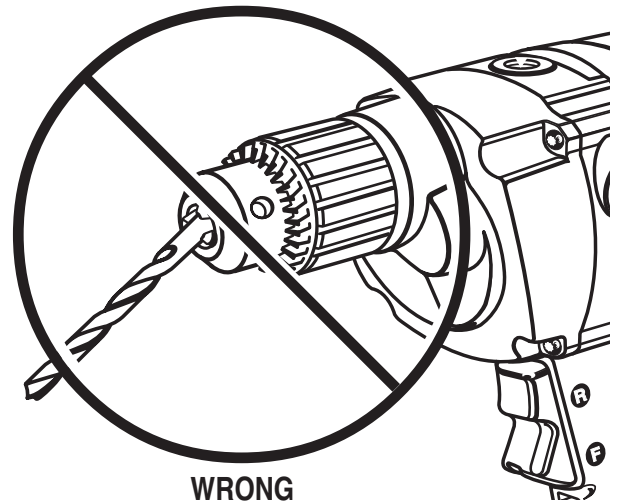

Fig. 5

# OPERATION

## ⚠ WARNING:

Exercise caution when using this tool. Careless actions, for even a fraction of a second, can result in serious personal injury.

## APPLICATIONS

You may use the spade handle drill for the purposes listed below:

- Drilling in wood
- Drilling in both hard and soft metals
- Using driving accessories, such as driving screws with screwdriver bits
- Mixing paints and drywall compounds

## ⚠ WARNING:

Always wear safety goggles or safety glasses with side shields when operating this tool. Failure to do so could result in dust, shavings, or loose particles being thrown into your eyes, resulting in possible serious injury.

## SWITCH

See Figure 6.

To turn the drill **ON**, depress the switch trigger. Release the switch trigger to turn the drill **OFF**.

## REVERSIBLE

See Figure 6.

The direction of chuck rotation is controlled by the rocker-type switch trigger. For clockwise drilling, depress the lower half of the switch trigger.

To reverse the direction to counterclockwise (for removing screws), depress the upper half of the switch trigger.

Release the switch trigger and allow the drill to stop before changing its direction.

## ⚠ CAUTION:

To prevent gear and motor damage, always allow the chuck to come to a complete stop before changing the direction of rotation.

## LOCK-ON BUTTON

See Figure 7.

This tool is equipped with a lock-on feature, which allows continuous operation for extended periods of time. To lock-on, depress the switch trigger. Push in and hold the lock-on button, located beneath the switch trigger, then release switch trigger. Release lock-on button and the drill will continue running.

**Note:** This feature applies only to operation in the forward direction.

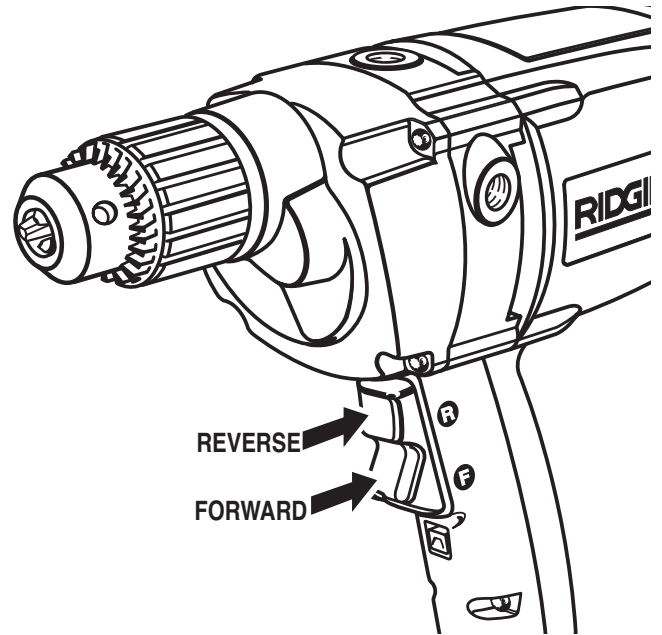

Fig. 6

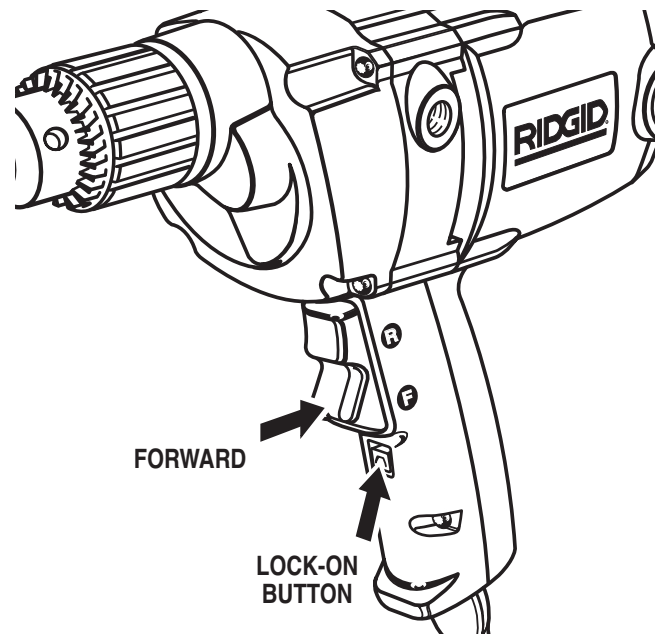

Fig. 7

To release the lock, depress the switch trigger and release. If you have the lock-on feature engaged during use and the drill becomes disconnected from power supply, disengage the lock-on feature immediately.

## ⚠ WARNING:

To avoid loss of control or serious personal injury, when drilling in lock-on mode, keep your hand positioned on the switch. This will allow you to stop the drill immediately in case binding occurs.

# OPERATION

## DRILLING

See Figures 8 and 9.

- Attach auxiliary handle (except for very light duty jobs)
- Depress and release the switch trigger to be sure the drill is in the **OFF** position before connecting it to power supply.
- Secure the material to be drilled in a vise or with clamps to keep it from turning as the drill bit rotates.
- Plug the drill into power supply source.
- Hold the drill firmly and place the bit at the point to be drilled.
- Depress the switch trigger to start the drill. Do not lock the switch **ON** for jobs where the drill may need to be stopped suddenly.
- Move the drill bit into the workpiece applying only enough pressure to keep the bit cutting. Do not force the drill or apply side pressure to elongate a hole. Let the drill and bit do the work.

### **⚠ WARNING:**

Be prepared for binding or bit breakthrough. When these situations occur, drill has a tendency to grab and kick opposite to the direction of rotation and could cause loss of control when breaking through material. If not prepared, this loss of control can result in possible serious injury.

When drilling hard smooth surfaces use a center punch to mark the desired hole location. This will prevent the drill bit from slipping off center as the hole is started.

When drilling metals use a light oil on the drill bit to keep it from overheating. The oil will prolong the life of the bit and increase the drilling action.

If the bit jams in the workpiece or if the drill stalls, stop the tool immediately. Remove the bit from the workpiece and determine the reason for jamming.

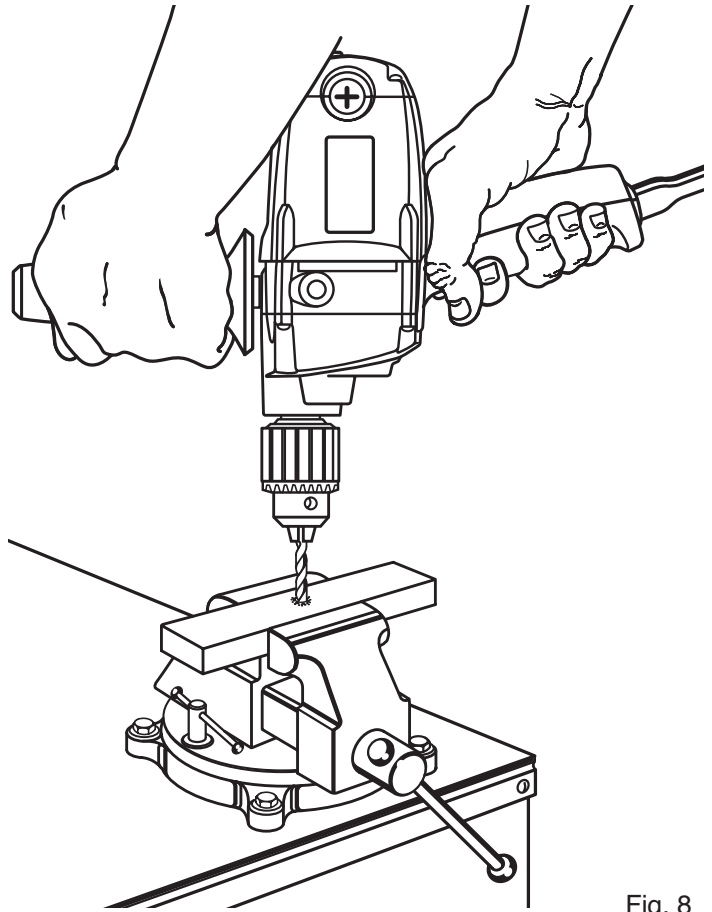

Fig. 8

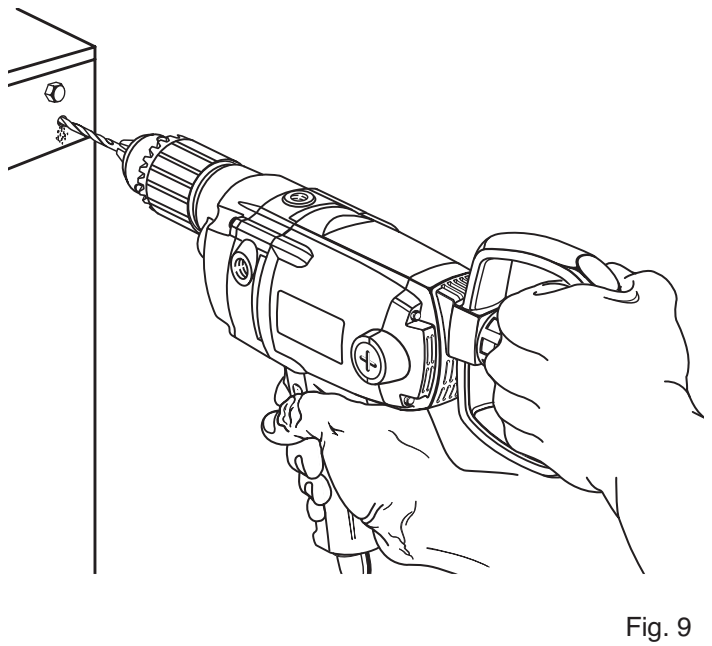

Fig. 9

# MAINTENANCE

## ⚠ WARNING:

This tool should never be connected to a power supply when you are assembling parts, making adjustments, cleaning, performing maintenance, or when the tool is not in use. Disconnecting the tool will prevent accidental starting that could cause serious injury.

## CHUCK REMOVAL

See Figure 10, 11, and 12.

The chuck must be removed in order to use some accessories. To remove:

- Unplug the drill.
- Open chuck jaws using the provided chuck key.
- Insert a 3/8 inch (10 mm) or larger hex key wrench into the chuck of the drill and tighten the chuck jaws securely.
- Tap the hex key wrench sharply with a mallet in a clockwise direction. See Figure 10. This will loosen the screw in the chuck for easy removal.
- Open chuck jaws and remove hex key. Remove the chuck screw by turning it in a clockwise direction. See Figure 11.

**Note:** The screw has left hand threads.

- Insert hex key wrench in the chuck and tighten chuck jaws securely.
- Tap sharply with a mallet in a counterclockwise direction. See Figure 12. This will loosen chuck on the spindle. It can now be unscrewed by hand.

## TO RETIGHTEN A LOOSE CHUCK

See Figure 10.

The chuck may become loose on the spindle and develop a wobble when using the drill. Periodically check chuck screw for tightness. A loose screw may cause the chuck jaws to bind and prevent them from closing. To tighten, follow these steps:

- Unplug the drill.
- Open the chuck jaws.
- Insert the hex key wrench into the chuck and tighten the chuck jaws securely. Tap the hex key sharply with a mallet in a clockwise direction. See Figure 10. This will tighten the chuck on the spindle.
- Open the chuck jaws and remove the hex key wrench.
- Tighten the chuck screw by turning counterclockwise.

**Note:** The chuck screw has left hand threads.

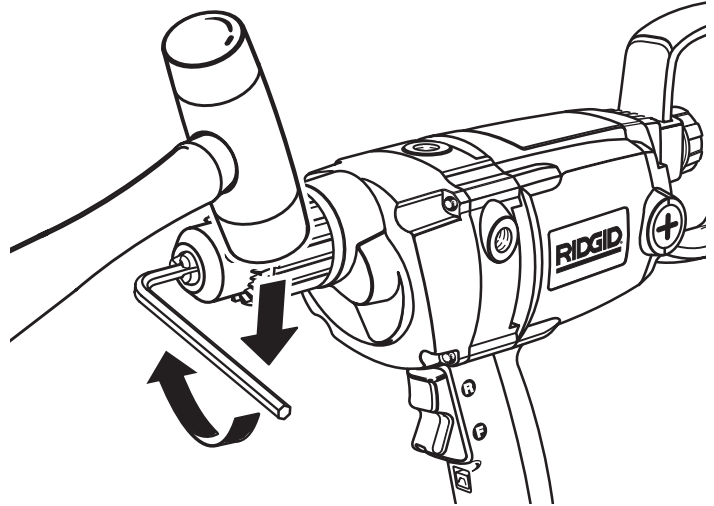

Fig. 10

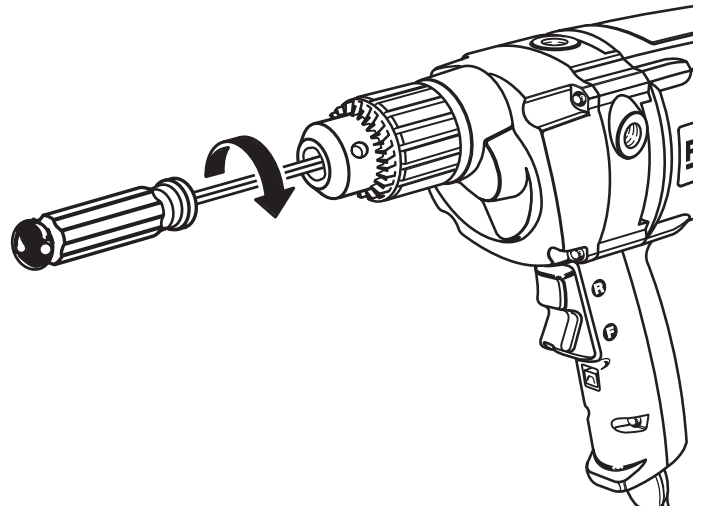

Fig. 11

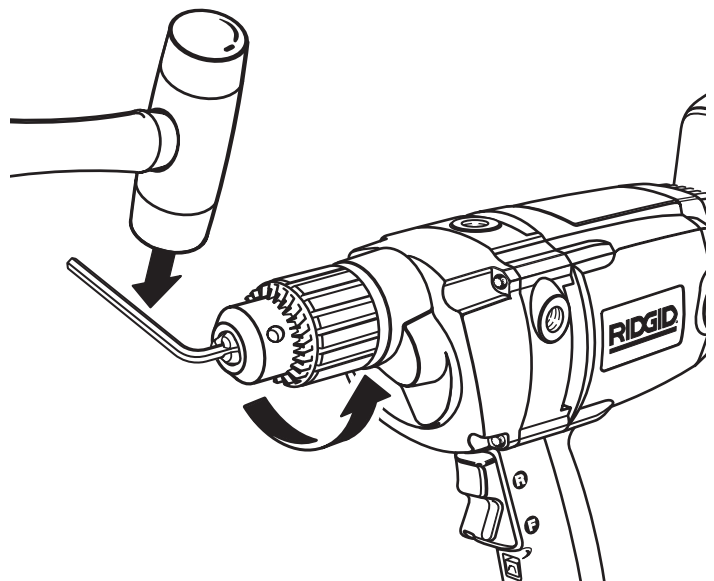

Fig. 12

# MAINTENANCE

---

## **⚠ WARNING:**

This tool should never be connected to a power supply when you are assembling parts, making adjustments, cleaning, performing maintenance, or when the tool is not in use. Disconnecting the tool will prevent accidental starting that could cause serious injury.

---

## **BRUSH REPLACEMENT**

See *Figure 13*.

The drill has externally accessible brush assemblies that should be periodically checked for wear.

Follow these steps to replace the brushes:

- Unplug the drill.
- Remove the brush cap with a flat blade screwdriver. The brush assembly is spring loaded and will pop out when you remove the brush cap.
- Remove the brush assembly (brush and spring).
- Check for wear. If worn, always replace in pairs.  
**Do not** replace one side without replacing the other.

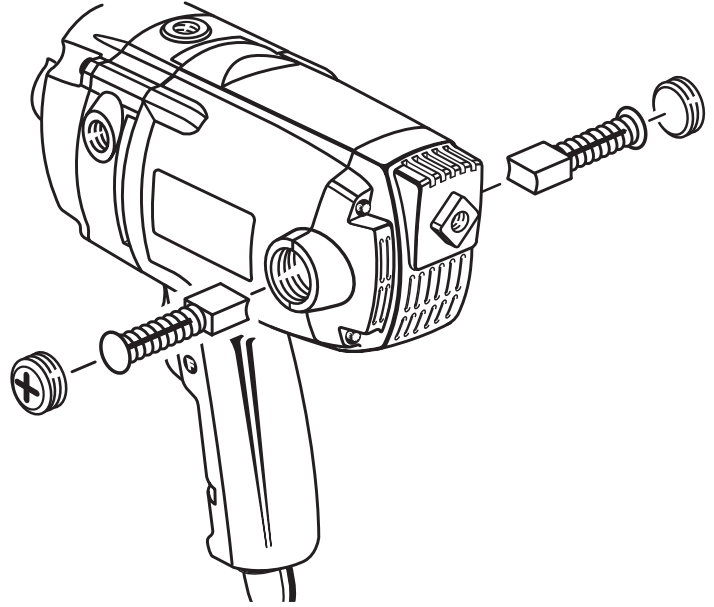

Fig. 13

---

# MAINTENANCE

---

## **WARNING:**

When servicing use only identical RIDGID® replacement parts. Use of any other parts may create a hazard or cause product damage.

---

## **GENERAL**

Avoid using solvents when cleaning plastic parts. Most plastics are susceptible to damage from various types of commercial solvents and may be damaged by their use. Use clean cloths to remove dirt, carbon dust, etc.

---

## **WARNING:**

Do not at any time let brake fluids, gasoline, petroleum-based products, penetrating oils, etc. come in contact with plastic parts. They contain chemicals that can damage, weaken, or destroy plastic.

---

Electric tools used on fiberglass material, wallboard, spackling compounds, or plaster are subject to accelerated wear and possible premature failure because the fiberglass chips and grindings are highly abrasive to bearings, brushes, commutators, etc. Consequently, we do not recommend using this tool for extended work on these types of materials. However, if you do work with any of these materials, it is extremely important to clean the tool using compressed air.

---

# ACCESSORIES

---

The following recommended accessories are currently available at retail stores:

- Mixing Wands
  - High Speed Bits ..... 1/2 in.(13 mm) Max.
  - Wood Boring Bits ..... 1-1/2 in. (32 mm) Max.
  - Self Feed ..... 2-9/16 in.(65 mm) Max.
  - Auger Bit ..... 1-1/2 in.(32 mm) Max.
  - Hole Saw, Steel ..... 3 in. (76.2 mm) Max.
  - Hole Saw, Wood ..... 5 in. (127 mm) Max.
- 

## **WARNING:**

The use of attachments or accessories not listed might be hazardous.

---

## **WARNING:**

Always wear safety goggles or safety glasses with side shields when operating this tool. Failure to do so could result in dust, shavings, or loose particles being thrown into your eyes, resulting in possible serious injury.

---

## **LUBRICATION**

All of the bearings in this tool are lubricated with a sufficient amount of high grade lubricant for the life of the tool under normal operating conditions. Therefore, no further lubrication is required.





# WARRANTY

---

## **RIDGID® HAND HELD AND STATIONARY POWER TOOL LIMITED THREE YEAR WARRANTY AND 90-DAY SATISFACTION GUARANTEE POLICY**

This product is manufactured under license from Ridgid, Inc. by One World Technologies, Inc. All warranty communications should be directed to One World Technologies, Inc. at (toll-free) 1-866-539-1710.

### **90-DAY SATISFACTION GUARANTEE POLICY**

During the first 90 days after the date of purchase, if you are dissatisfied with the performance of this RIDGID tool for any reason you may return the tool to the dealer from which it was purchased for a full refund or exchange. To receive a replacement tool you must present proof of purchase and return all original equipment packaged with the original product. The replacement tool will be covered by the limited warranty for the balance of the three year warranty period.

### **WHAT IS COVERED UNDER THE LIMITED THREE YEAR WARRANTY**

This warranty covers all defects in workmanship or materials in this RIDGID tool for the three year period from the date of purchase. This warranty is specific to this tool. Warranties for other RIDGID products may vary.

### **HOW TO OBTAIN SERVICE**

To obtain service for this RIDGID tool, you must return it, freight prepaid, to an authorized RIDGID service center for hand held and stationary power tools. You may obtain the location of the authorized service center nearest you by calling (toll-free) 1-866-539-1710 or by logging on to the RIDGID website at [www.ridgidwoodworking.com](http://www.ridgidwoodworking.com). When requesting warranty service, you must present the proof of purchase documentation, which includes a date of purchase. The authorized service center will repair any faulty workmanship, and either repair or replace any defective part, at our option at no charge to you.

### **WHAT IS NOT COVERED**

This warranty applies only to the original purchaser at retail and may not be transferred. This warranty only covers defects arising under normal usage and does not cover any malfunction, failure or defect resulting from misuse, abuse, neglect, alteration, modification or repair by other than an authorized RIDGID service center for hand held and stationary power tools. One World Technologies, Inc. makes no warranties, representations or promises as to the quality or performance of its power tools other than those specifically stated in this warranty.

### **ADDITIONAL LIMITATIONS**

To the extent permitted by applicable law, all implied warranties, including warranties of MERCHANTABILITY or FITNESS FOR A PARTICULAR PURPOSE, are disclaimed. Any implied warranties, including warranties of merchantability or fitness for a particular purpose, that cannot be disclaimed under state law are limited to three years from the date of purchase. One World Technologies, Inc. is not responsible for direct, indirect, incidental or consequential damages. Some states do not allow limitations on how long an implied warranty lasts and/or do not allow the exclusion or limitation of incidental or consequential damages, so the above limitations may not apply to you. This warranty gives you specific legal rights, and you may also have other rights which vary from state to state.

---

**One World Technologies, Inc.**  
Hwy. 8  
Pickens, SC 29671

---

**OPERATOR'S MANUAL**  
**R7120**  
**Single Speed/Reversible**  
**Double Insulated**



**Customer Service Information:**

For parts or service, contact your nearest RIDGID authorized service center. Be sure to provide all relevant information when you call or visit. For the location of the authorized service center nearest you, please call 1-866-539-1710 or visit us online at [www.ridgidwoodworking.com](http://www.ridgidwoodworking.com).

The model number of this tool is found on a plate attached to the motor housing. Please record the serial number in the space provided below. When ordering repair parts, always give the following information:

**Model No.** \_\_\_\_\_ R7120 \_\_\_\_\_

**Serial No.** \_\_\_\_\_