

Reebok® RT 300

Model No. RBEX2976.3

Serial No. _____

Write the serial number in the space above for future reference.

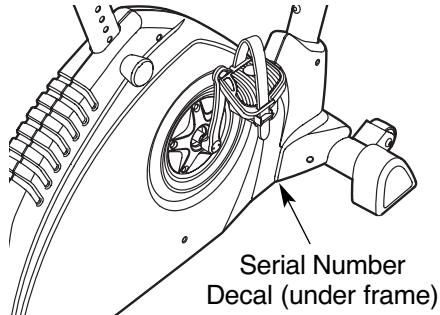

QUESTIONS?

As a manufacturer, we are committed to providing complete customer satisfaction. If you have questions, or if parts are missing, **PLEASE DO NOT CONTACT THE STORE;** please contact Customer Care.

IMPORTANT: You must note the product model number and serial number (see the drawing above) before contacting us:

CALL TOLL-FREE:

1-877-994-4999

Mon.–Fri., 6 a.m.–6 p.m. MST

Sat. 8 a.m.–4 p.m. MST

ON THE WEB:

www.reebokservice.com

⚠ CAUTION

Read all precautions and instructions in this manual before using this equipment. Keep this manual for future reference.

USER'S MANUAL

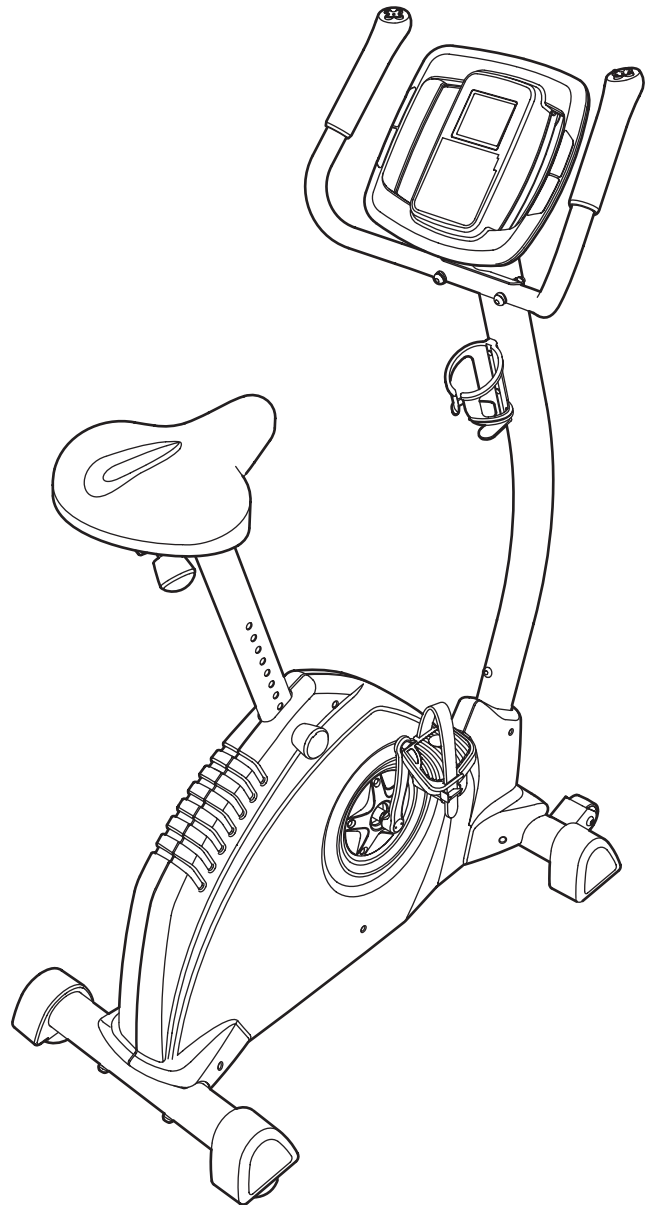

Visit our website at

www.reebokhomefitness.com

new products, prizes,
fitness tips, and much more!

TABLE OF CONTENTS

WARNING DECAL PLACEMENT	2
IMPORTANT PRECAUTIONS	3
BEFORE YOU BEGIN	4
ASSEMBLY	5
EXERCISE CYCLE OPERATION	10
MAINTENANCE AND TROUBLESHOOTING	17
EXERCISE GUIDELINES	18
PART LIST	22
EXPLODED DRAWING	23
ORDERING REPLACEMENT PARTSBack Cover
LIMITED WARRANTYBack Cover

WARNING DECAL PLACEMENT

The warning decal shown here has been applied in the location shown. **If the decal is missing or illegible, call the telephone number on the front cover of this manual and request a free replacement decal. Apply the decal in the location shown.** Note: The decal may not be shown at actual size.

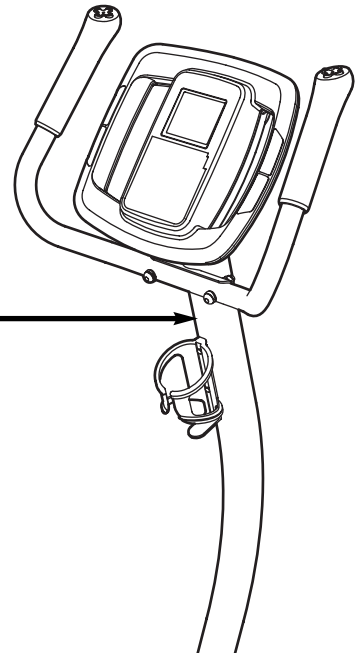
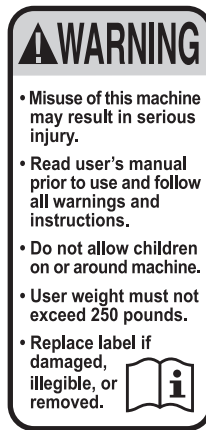

IMPORTANT PRECAUTIONS

⚠ WARNING: To reduce the risk of serious injury, read all important precautions and instructions in this manual and all warnings on your exercise cycle before using your exercise cycle. ICON assumes no responsibility for personal injury or property damage sustained by or through the use of this product.

1. Before beginning any exercise program, consult your physician. This is especially important for persons over the age of 35 or persons with pre-existing health problems.
2. Use the exercise cycle only as described in this manual.
3. It is the responsibility of the owner to ensure that all users of the exercise cycle are adequately informed of all precautions.
4. The exercise cycle is intended for home use only. Do not use the exercise cycle in a commercial, rental, or institutional setting.
5. Keep the exercise cycle indoors, away from moisture and dust. Place the exercise cycle on a level surface, with a mat beneath it to protect the floor or carpet. Make sure that there is enough clearance around the exercise cycle to mount, dismount, and use it.
6. Inspect and properly tighten all parts regularly. Replace any worn parts immediately.
7. Keep children under the age of 12 and pets away from the exercise cycle at all times.
8. Wear appropriate clothes while exercising; do not wear loose clothes that could become caught on the exercise cycle. Always wear athletic shoes for foot protection.
9. The exercise cycle should not be used by persons weighing more than 250 lbs. (113 kg).
10. The pulse sensor is not a medical device. Various factors, including the user's movement, may affect the accuracy of heart rate readings. The pulse sensor is intended only as an exercise aid in determining heart rate trends in general.
11. Always keep your back straight while using the exercise cycle; do not arch your back.
12. If you feel pain or dizziness while exercising, stop immediately and cool down.

BEFORE YOU BEGIN

Congratulations for selecting the revolutionary REEBOK® RT 300 exercise cycle. Cycling is one of the most effective exercises for increasing cardiovascular fitness, building endurance, and toning the entire body. The RT 300 exercise cycle offers an impressive array of features, including a console with two motivational interactive games, designed to let you enjoy this healthful exercise in the comfort and convenience of your home.

For your benefit, read this manual carefully before you use the exercise cycle. If you have questions after reading this manual, please see the front cover

of this manual. To help us assist you, note the product model number and serial number before contacting us. The model number and the location of the serial number decal are shown on the front cover of this manual.

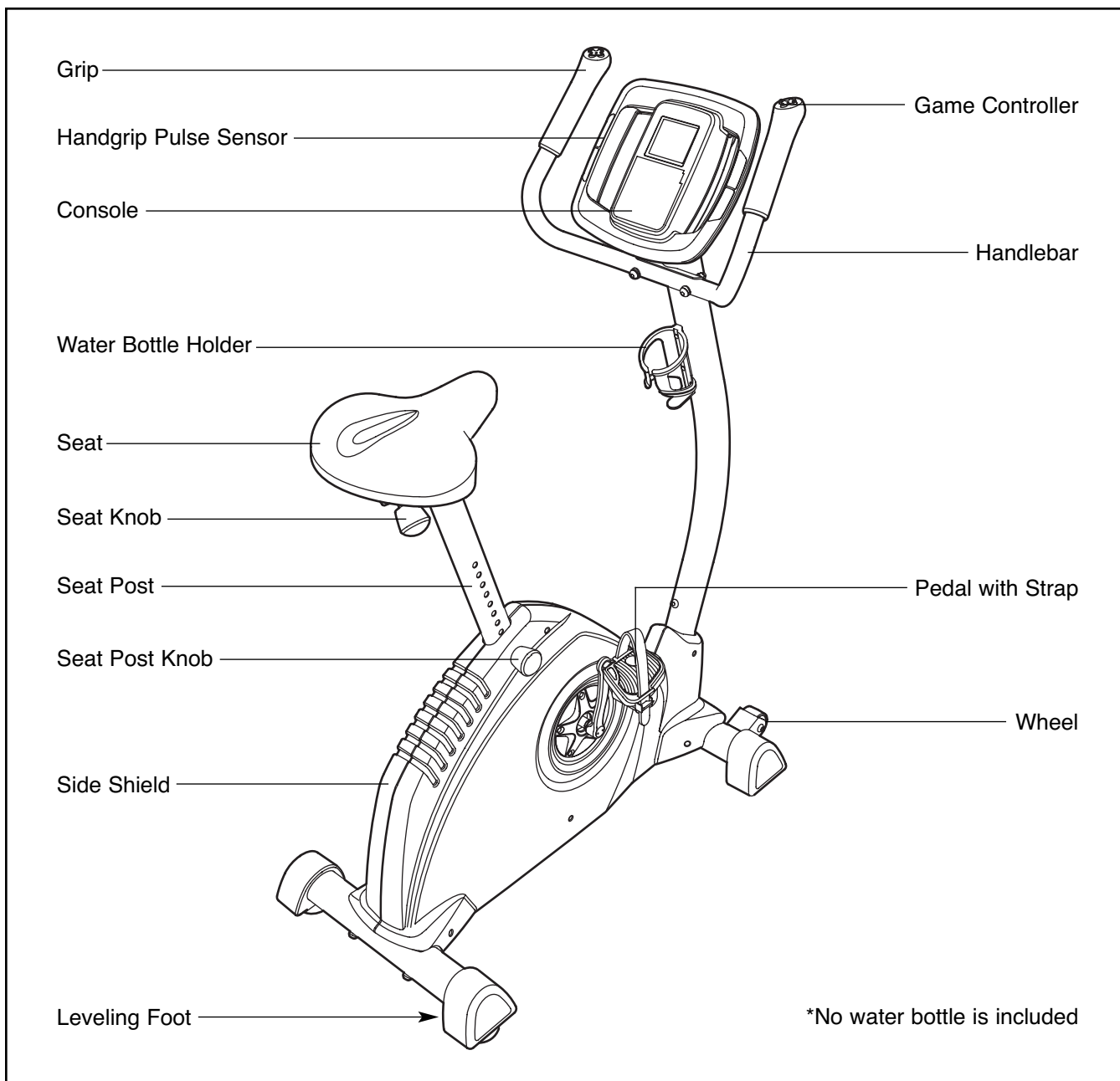

To avoid a registration fee for any service needed under warranty, you must register the exercise cycle at www.reebokservice.com/registration.

Before reading further, please familiarize yourself with the parts that are labeled in the drawing below.

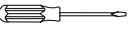

ASSEMBLY

To hire an authorized service technician to assemble the exercise cycle, call 1-800-445-2480.

Assembly requires two persons. Place all parts of the exercise cycle in a cleared area and remove the packing materials. Do not dispose of the packing materials until assembly is completed. **In addition to the included tools, assembly requires a Phillips screwdriver** , **an adjustable wrench** , and **a rubber mallet** .

As you assemble the exercise cycle, use the drawings below to identify small parts. The number in parentheses below each drawing is the key number of the part, from the PART LIST near the end of this manual. The number following the parentheses is the quantity needed for assembly. **Note: Some small parts may have been pre-assembled. If a part is not in the hardware kit, check to see if it has been pre-assembled.**

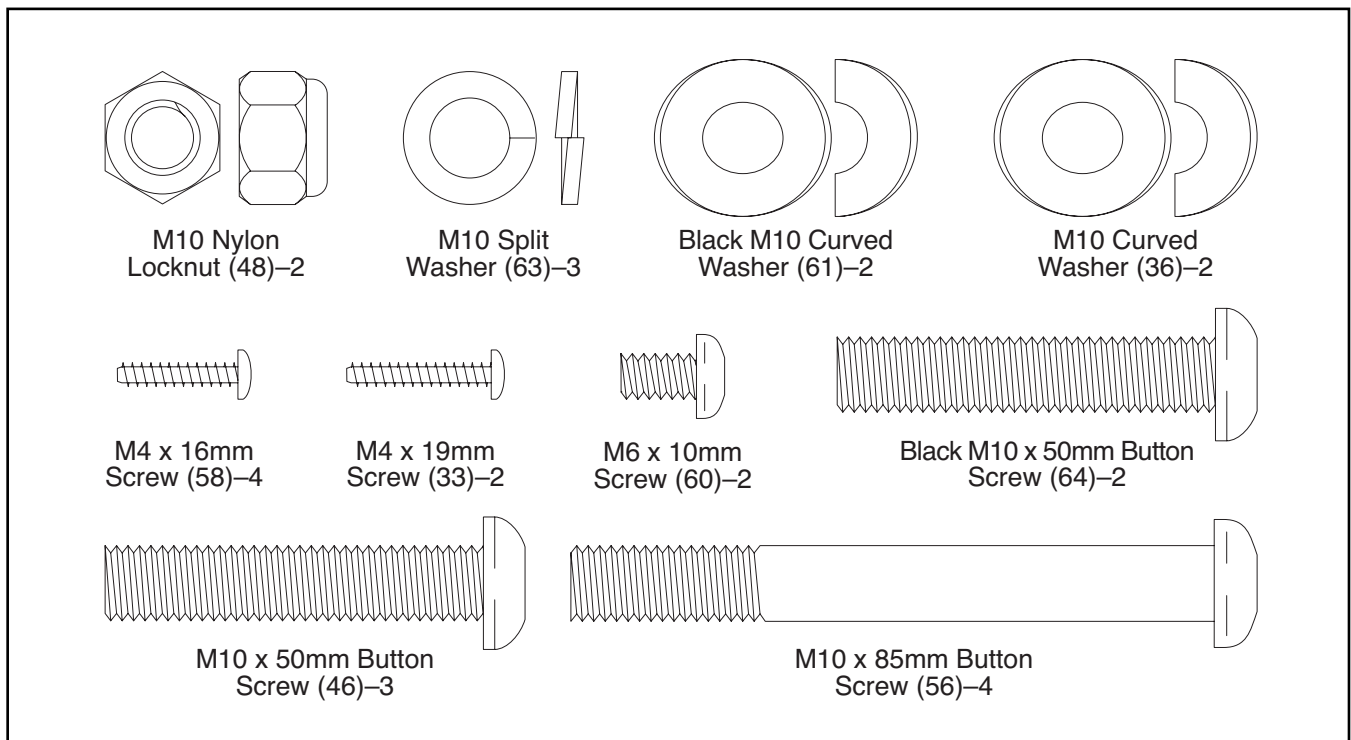

1.

To make assembly easier, read the information on page 5 before you begin assembling the exercise cycle.

Identify the Front Stabilizer (2), which has Wheels (17) attached. Attach the Front Stabilizer to the Frame (1) with two M10 x 85mm Button Screws (56).

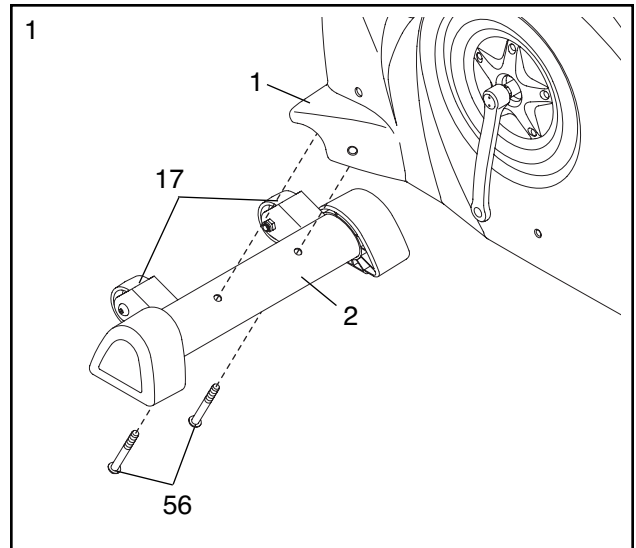

2. Tighten the two Leveling Feet (29) into the bottom of the Rear Stabilizer (3).

Attach the Rear Stabilizer (3) to the Frame (1) with two M10 x 85mm Button Screws (56).

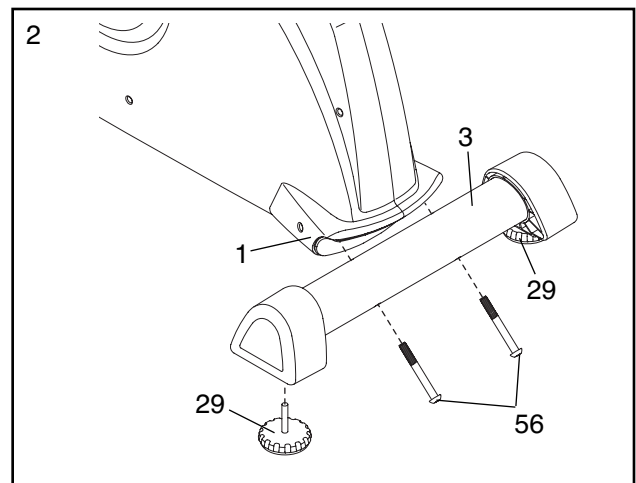

- While another person holds the Handlebar Post (6) near the Frame (1), connect the Upper Wire Harness (55) to the Lower Wire Harness (51). Next, pull the excess Upper Wire Harness out of the top of the Handlebar Post, and slide the Handlebar Post onto the Frame. **Tip: Avoid pinching the Wire Harnesses during this step.**

Attach the Handlebar Post (6) to the Frame (1) with three M10 x 50mm Button Screws (46) and three M10 Split Washers (63); **tighten the two Button Screws in the front of the Handlebar Post first, and then tighten the third Button Screw.**

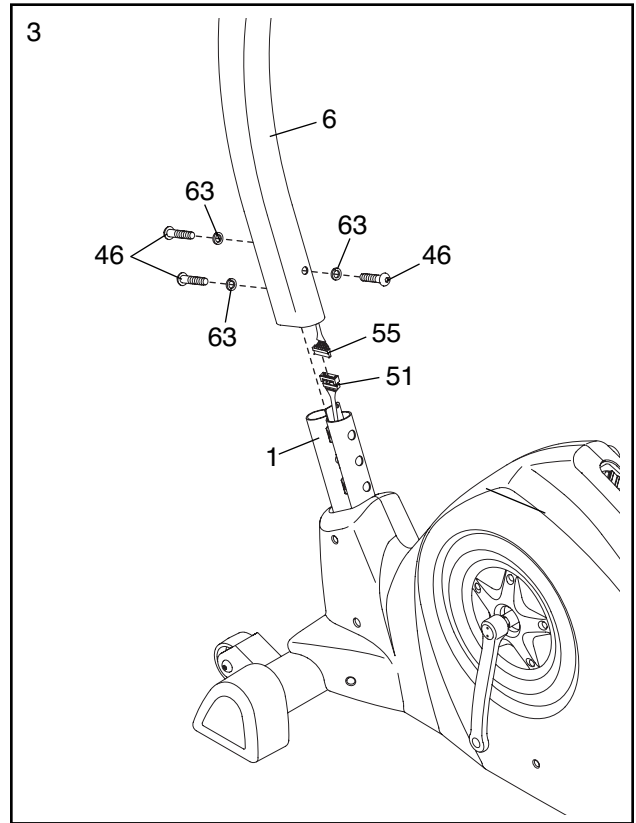

- Attach the Water Bottle Holder (18) to the Handlebar Post (6) with two M4 x 19mm Screws (33).

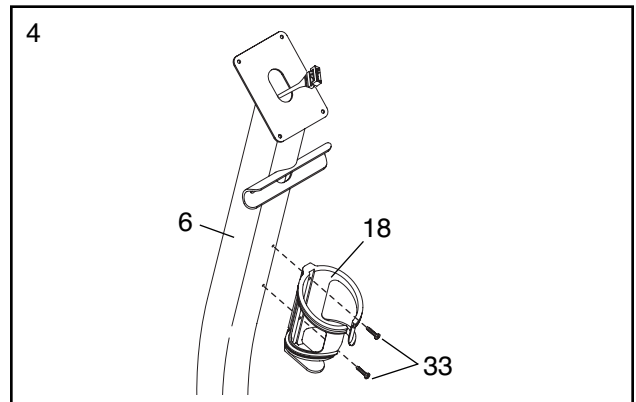

- Have a second person hold the Handlebar (7) near the Handlebar Post (6). Insert the Controller Wires (54) into the hole in the Handlebar Post and pull them upward out of the top of the Handlebar Post.

Attach the Handlebar (7) to the Handlebar Post (6) with two Black M10 x 50mm Button Screws (64), two Black M10 Curved Washers (61), two M10 Curved Washers (36), and two M10 Nylon Locknuts (48). **Tip: Avoid pinching the wires during this step.**

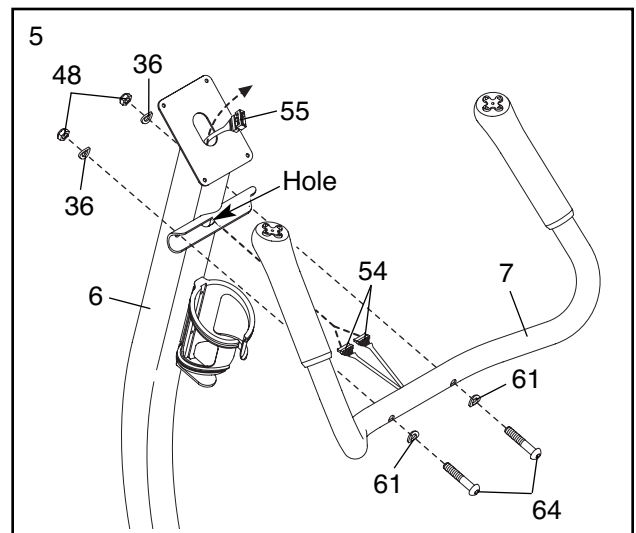

6. The Console (9) requires four 1.5V “D” batteries (not included); alkaline batteries are recommended. **IMPORTANT: If the exercise cycle has been exposed to cold temperatures, allow it to warm to room temperature before inserting batteries into the Console. If you do not do this, the console displays or other electronic components may become damaged.** Press the tab on the battery cover and remove the battery cover. Next, insert four batteries into the Console. **Make sure that the batteries are oriented as shown by the diagram inside the battery compartment.** Then, reattach the battery cover to the Console.

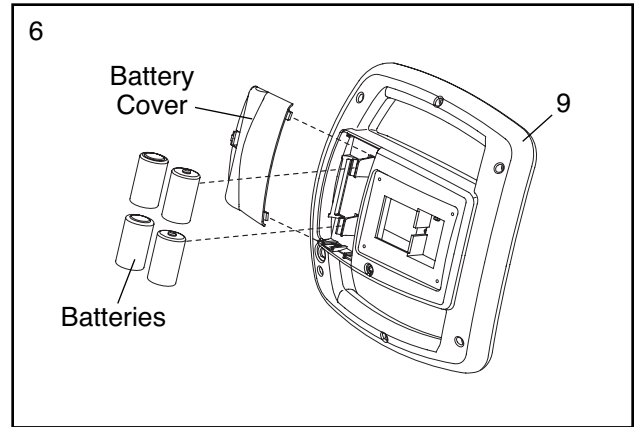

7. Note: A long cable may be attached to the Console (9). The long cable is used during the manufacturing process. Remove and discard the long cable before continuing this step.

Have a second person hold the Console (9) near the Handlebar Post (6). Connect the console wire harness to the Upper Wire Harness (55). Next, connect the game wire that has a tag to the Controller Wire (54) that has a tag. Then, connect the other game wire to the other Controller Wire.

Attach the Console (9) to the Handlebar Post (6) with four M4 x 16mm Screws (58). **Tip: Avoid pinching the wires in the Console.**

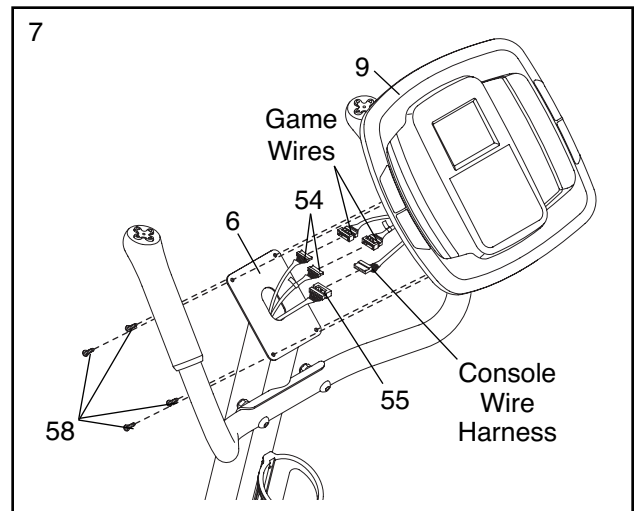

8. Turn the Seat Post Knob (20) counterclockwise several turns to loosen it. Next, pull the Seat Post Knob outward, and insert the Seat Post (11) into the Frame (1). Slide the Seat Post upward or downward to the desired position, and release the Seat Post Knob. **Move the Seat Post up or down slightly to make sure that the Seat Post Knob is engaged in one of the adjustment holes in the Seat Post.** Then, turn the Seat Post Knob clockwise to tighten it.

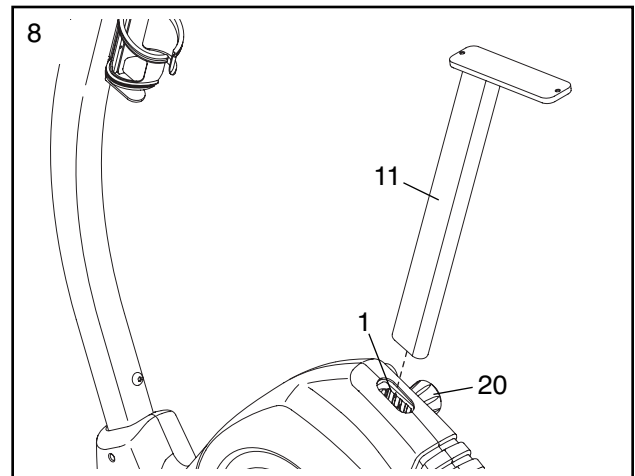

9. Attach an M6 x 10mm Screw (60) to the Seat Post (11). Next, slide the Seat Carriage (19) onto the Seat Post. Then, adjust the Seat Carriage to the desired position and tighten the Seat Knob (31) into the Seat Carriage.

See the inset drawing. Attach another M6 x 10mm Screw (60) to the Seat Post (11).

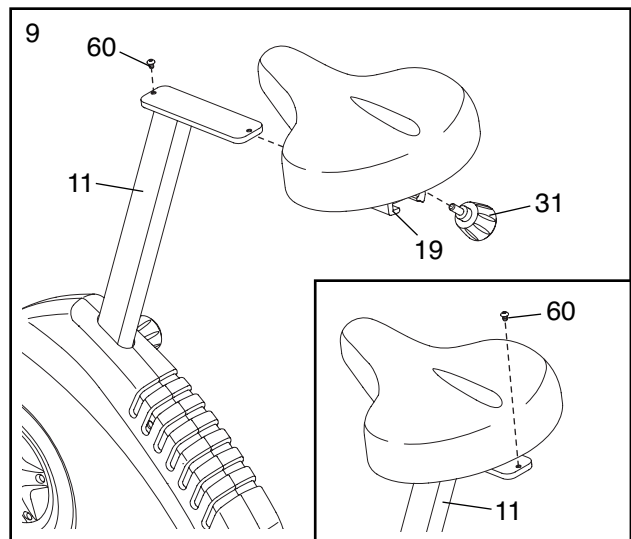

10. Identify the Left Pedal (40), which is marked with a sticker. Using an adjustable wrench, **firmly tighten** the Left Pedal *counterclockwise* into the Left Crank Arm (15). Tighten the Right Pedal (not shown) *clockwise* into the Right Crank Arm. **IMPORTANT: Tighten both Pedals as firmly as possible. After using the exercise cycle for one week, retighten the Pedals. For best performance, keep the Pedals tightened.**

Press the tab on the side of the Left Pedal (40) and adjust a Pedal Strap (25) to the desired position. Adjust the other Pedal Strap (not shown) in the same way.

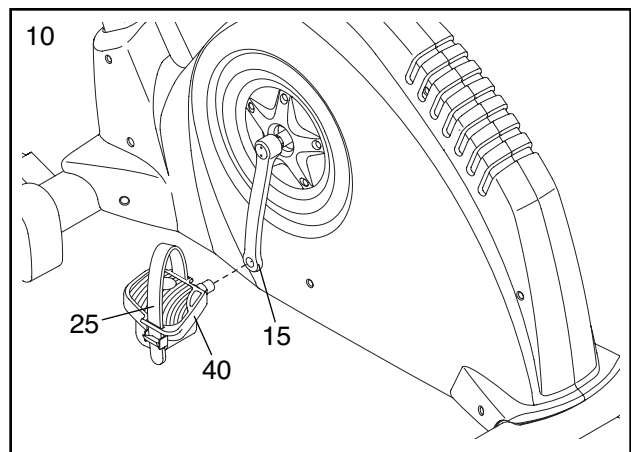

11. **Make sure that all parts are properly tightened before you use the exercise cycle. Note: Some hardware may be left over after assembly is completed.** Place a mat under the exercise cycle to protect the floor or carpet.

EXERCISE CYCLE OPERATION

HOW TO ADJUST THE HEIGHT OF THE SEAT

For effective exercise, the seat should be at the proper height. As you pedal, there should be a slight bend in your knees when the pedals are in the lowest position.

To adjust the seat, first turn the seat post knob counter-clockwise several turns to loosen it. Next, pull the knob, slide the seat post upward or downward to the desired position, and then release the knob. **Move the seat post up or down slightly to make sure that the knob is engaged in one of the adjustment holes in the seat post.** Then, turn the knob clockwise to tighten it.

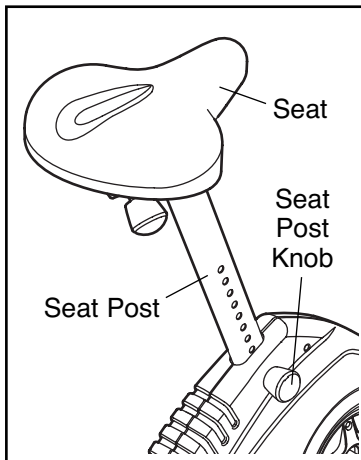

HOW TO ADJUST THE LATERAL POSITION OF THE SEAT

To adjust the lateral position of the seat, first loosen the seat knob a few turns. Then, move the seat forward or backward to the desired position, and firmly tighten the seat knob.

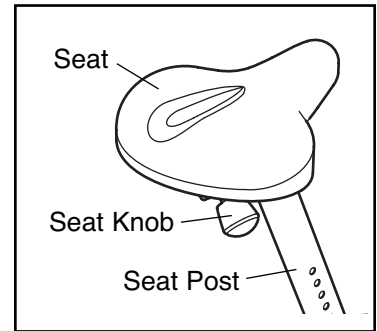

HOW TO ADJUST THE PEDAL STRAPS

To loosen the pedal straps, press the tabs and pull the straps upward. To tighten the pedal straps, pull downward on the ends of the straps.

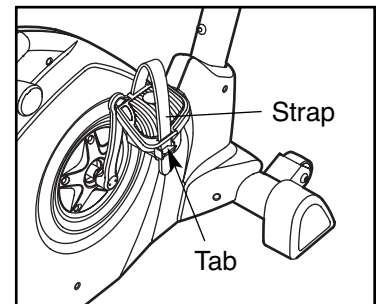

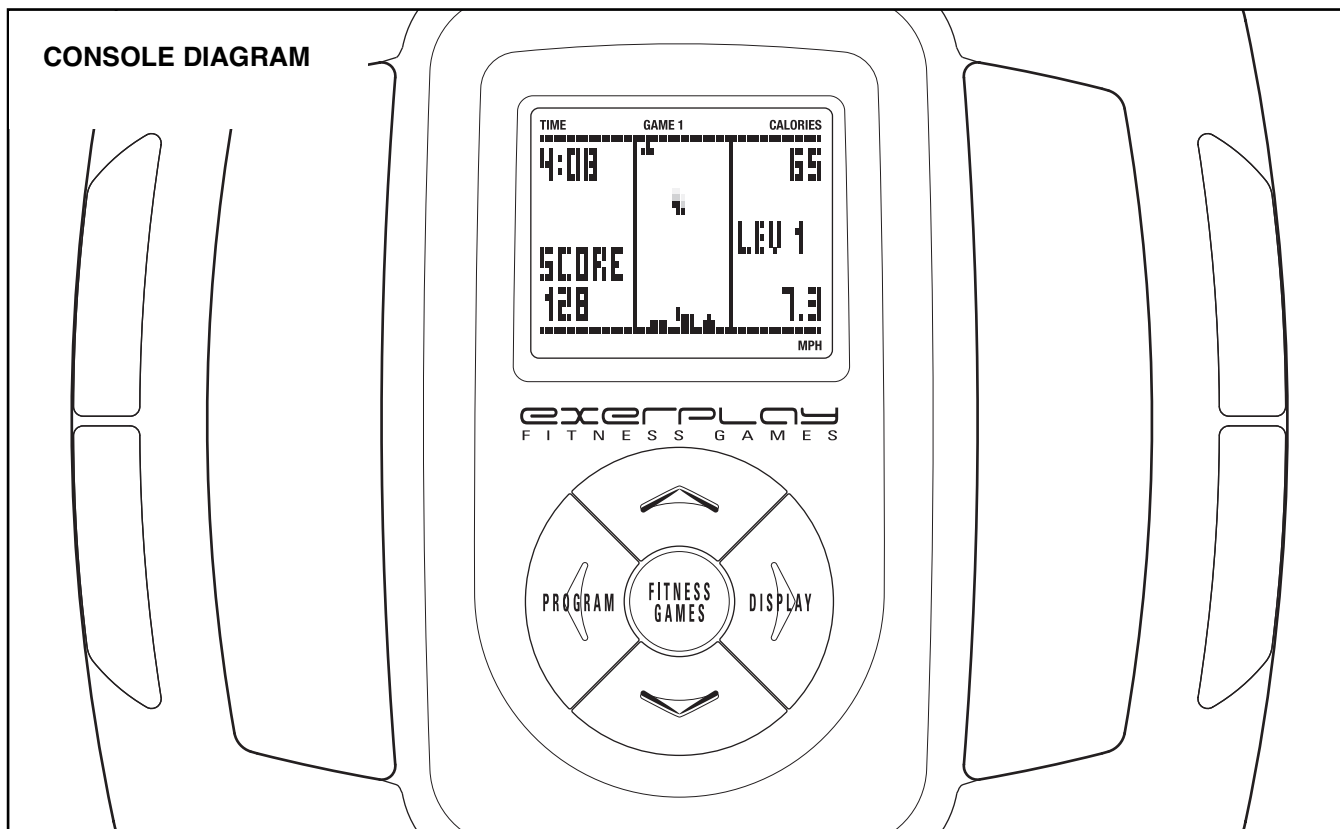

FEATURES OF THE CONSOLE

The revolutionary console offers an array of features designed to make your workouts more effective and enjoyable. When you use the manual mode of the console, you can change the resistance of the pedals with the touch of a button. While you exercise, the console will display continuous exercise feedback. You can even measure your heart rate using the handgrip pulse sensor.

Smart Programs

The console offers eight smart programs. Each program automatically changes the resistance of the pedals and prompts you to vary your pedaling pace as it guides you through an effective workout.

Interactive Games

The console also features two motivational interactive games. Using the dual game controllers, play the challenging Fat Blocker™ game or the fast-paced Calorie Destroyer™ game during your workouts—the harder you exercise, the greater the advantage you will have! The console keeps track of the four highest scores for each game—compete with other users or try to top your own high score.

To use the manual mode of the console, follow the steps beginning on page 12. **To use a smart program**, see page 13. **To play the Fat Blocker game**, see page 15. **To play the Calorie Destroyer game**, see page 16.

HOW TO USE THE MANUAL MODE

Note: If there is a sheet of clear plastic on the face of the console, remove the plastic.

1. Begin pedaling or press any button on the console to turn on the console.

A moment after you begin pedaling or press a button, the display will light.

2. Select the manual mode.

Each time you turn on the console, the manual mode will be selected. If you have selected a program, reselect the manual mode by pressing the Program button repeatedly until the words MANUAL MODE appear in the lower left corner of the display.



3. Change the resistance of the pedals as desired.

As you pedal, change the resistance of the pedals by pressing the increase and decrease buttons repeatedly. Note: After you press the buttons, it will take a moment for the pedals to reach the selected resistance level.



4. Follow your progress with the display.

The upper left corner of the display will show the elapsed time. Note: When a program is selected, the display will show the time remaining in the program instead of the elapsed time.

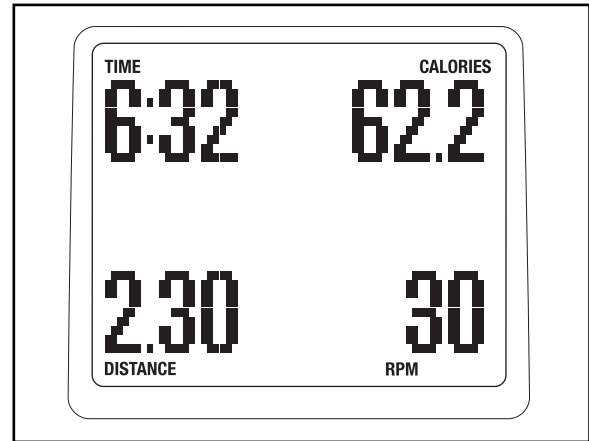

The lower left corner of the display will show the distance you have pedaled, in miles or kilometers.

The upper right corner of the display will show the approximate number of calories you have burned. The upper right corner of the display will also show your heart rate when you use the hand-grip pulse sensor (see step 5 on page 13).

The lower right corner of the display will show your pedaling pace in miles or kilometers per hour.

The center of the display will show the resistance setting of the pedals for a few seconds each time the resistance setting changes.

You can also view selected information at a larger size. Press the Display button repeatedly to view time and distance information, time and calorie information, or time and pace information. Press the Display button again to view all information.

The console has three backlight options. The "On" option keeps the backlight on while the console is on. To conserve the batteries, the "Auto" option keeps the backlight on only while you are pedaling. The "Off" option turns the backlight off. To select a backlight option, first press and hold down the Program button for several seconds. Next, press the increase button to select the desired backlight option. Then, press the Program button to save your selection.

The console can show speed and distance in either miles or kilometers. The letters MPH or KM/H will appear in the display to show which unit of measurement is selected. To change the unit of measurement, first press and hold down the Program button for several seconds. Next, press the decrease button to select the desired unit of measurement. Then, press the Program button to save your selection.

5. Measure your heart rate if desired.

If there are sheets of clear plastic on the metal contacts on the handgrip pulse sensor, remove the plastic. To measure your heart rate, hold the handgrip pulse sensor with your palms resting against the metal contacts. **Avoid moving your hands or gripping the contacts too tightly.**

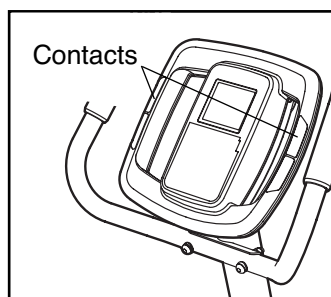

When your pulse is detected, one, two, or three dashes will appear, and then your heart rate will be shown. For the most accurate heart rate reading, hold the contacts for at least 15 seconds. Note: If you continue to hold the handgrip pulse sensor, the display will show your heart rate for up to 30 seconds.

If the display does not show your heart rate, make sure that your hands are positioned as described. Be careful not to move your hands excessively or to squeeze the metal contacts too tightly. For optimal performance, clean the metal contacts using a soft cloth; **never use alcohol, abrasives, or chemicals to clean the contacts.**

6. When you are finished exercising, the console will turn off automatically.

If the pedals do not move for several seconds, a tone will sound and the console will pause. If the pedals do not move for several minutes and the buttons are not pressed, the console will turn off and the display will be reset.

HOW TO USE A SMART PROGRAM

1. Begin pedaling or press any button on the console to turn on the console.

A moment after you begin pedaling or press a button, the display will light.

2. Select a smart program.

To select one of the eight smart programs, press the Program button repeatedly until PROGRAM 1, 2, 3, 4, 5, 6, 7, or 8 appears in the display. The program time and a profile of the resistance settings for the program will also appear in the display.

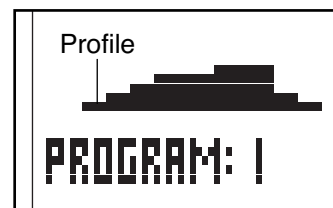

3. Begin pedaling to start the program.

Each program is divided into either 20 or 30 one-minute segments. One resistance setting and one target pace setting are programmed for each segment. Note: The same resistance setting and/or target pace setting may be programmed for two or more consecutive segments.

The resistance setting and the target pace setting for the first segment will appear in the center of the display for a few seconds. The resistance setting will then be indicated by the height of the flashing column of the profile in the display. The resistance settings for the next several segments will be indicated by the heights of the columns to the right of the flashing column.

When the first segment of the program ends, the resistance setting and the target pace setting for the second segment will appear in the center of the display for a few seconds to alert you. The entire profile will then shift one column to the left, and the pedals will automatically adjust to the resistance setting for the second segment.

As you exercise, you will be prompted to keep your pedaling pace near the target pace setting for the current segment. When an upward arrow appears in the display, increase your pace. When a downward arrow appears in the display, decrease your pace. When no arrows appear, maintain your current pace.

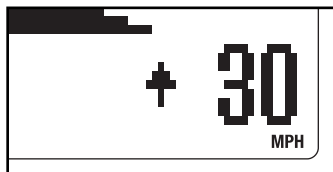

IMPORTANT: The target pace settings are intended only to provide motivation. Your actual pace may be slower than the target pace settings. Make sure to exercise at a pace that is comfortable for you.

If the resistance setting for the current segment is too high or too low, you can manually override the setting by pressing the increase and decrease buttons. **IMPORTANT: When the current segment of the program ends, the pedals will automatically adjust to the resistance setting for the next segment.**

The program will continue in this way until the last segment ends. To stop the program at any time, stop pedaling. A tone will sound and the time will begin to flash in the display. To restart the program, simply resume pedaling.

4. Follow your progress with the display.

See step 4 on page 12.

5. Measure your heart rate if desired.

See step 5 on page 13.

6. When you are finished exercising, the console will turn off automatically.

See step 6 on page 13.

HOW TO PLAY THE FAT BLOCKER GAME

The Fat Blocker game requires quick thinking and fast reflexes. In addition to the console buttons, you will use the four-button game controllers on the handlebar to play the game. Follow the steps below to play the Fat Blocker game.

- 1. Begin pedaling or press any button on the console to turn on the console.**

A moment after you begin pedaling or press a button, the display will light.

- 2. Select the Fat Blocker game.**

To select the Fat Blocker game, press the Fitness Games button repeatedly until the words FAT BLOCKER appear at the top of the display.

- 3. Press a button on either controller to start the game.**

When you start the Fat Blocker game, a game arena will appear in the center of the display.

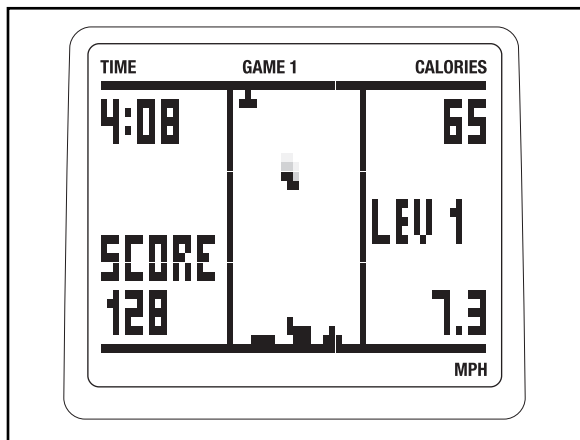

A block composed of four or five black squares will slowly move downward until it reaches the bottom of the arena. Another block will then move downward. Blocks come in eight different shapes. As each block falls, you can move it to the left or right using the left and right buttons on the left controller. In addition, you can rotate the block counterclockwise or clockwise using the left and right buttons on the right controller. Once you have positioned and oriented a block, you can speed its motion to the bottom of the arena, if desired, by pressing the down button on either controller.

Your goal is to maneuver the blocks so that they form a complete row of black squares across the entire arena. Each time you complete a row of black squares, the row will disappear, and all blocks above will move downward one row.

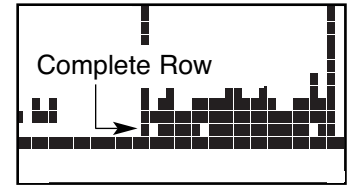

As you play, the blocks will fall faster and faster; however, your pedaling pace will affect the speed of the blocks—the faster you pedal, the more slowly the blocks will fall, giving you extra time to position and orient the blocks. The game will continue until any part of a stacked block reaches the top of the arena.

When the game ends, the display will show your final score and the level of play that you reached. The display will then show the four highest scores recorded since the scores were reset. If desired, press and hold down the right button on either controller to reset the scores. Note: If your score is one of the four highest, the display will prompt you to enter a name consisting of three letters or digits. While the line below the first letter is flashing, press the up and down buttons on either controller to select the desired letter or digit. Next, press the right button on either controller and select another letter or digit. Repeat this process to select a third letter or digit. Then, press the right button on either controller again. The display will then show the four highest scores recorded since the scores were reset.

- 4. Follow your progress with the display.**

While you exercise and play the Fat Blocker game, the corners of the display will show the elapsed time, the approximate number of calories you have burned, and your pedaling pace. In addition, the display will show your current score and the game level that you have reached.

To pause the game, press the Display button. To resume the game, press the Display button repeatedly until the words FAT BLOCKER appear at the top of the display, and then press a button on either controller.

- 5. When you are finished exercising, the console will turn off automatically.**

See step 6 on page 13.

HOW TO PLAY THE CALORIE DESTROYER GAME

The Calorie Destroyer game is a fast-paced game that pits you against a squadron of laser-firing drones. In addition to the console buttons, you will use the four-button game controllers on the handlebar to play the game. Follow the steps below to play the Calorie Destroyer game.

1. Begin pedaling or press any button on the console to turn on the console.

A moment after you begin pedaling or press a button, the display will light.

2. Select the Calorie Destroyer game.

To select the Calorie Destroyer game, press the Fitness Games button repeatedly until the word DESTROYER appears at the top of the display.

3. Pedal to start the game.

When you start the Calorie Destroyer game, a game arena will appear in the display. Three rows of drones will begin to move across the top of the arena, periodically firing their lasers downward. Each time the drones reach the left or right side of the arena, they will reverse direction and move downward.

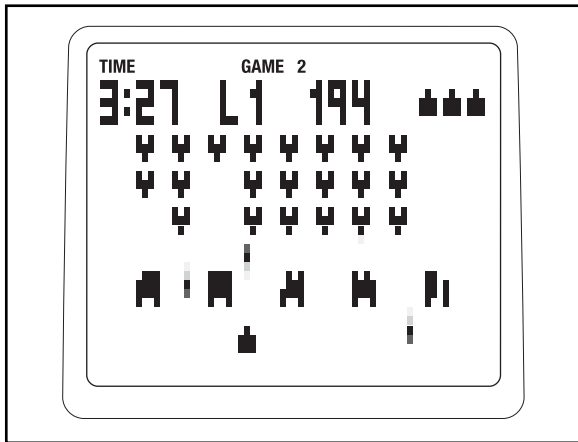

At the bottom of the arena is a laser blaster. You can fire the laser blaster at the drones by pressing the up button on either controller. In addition, while you are pedaling, you can move the laser blaster to the left or right using the left and right buttons on either controller. The faster you pedal, the faster the laser blaster will move.

Between the drones and the laser blaster are five shields. You can hide the laser blaster below a shield if desired. However, each time a shield is hit by a laser, a piece will be vaporized.

Your goal is to keep the laser blaster from being hit and to keep any drone from reaching the bottom of the arena. If the laser blaster is hit, it will be disabled and another laser blaster will appear in its place; there are a total of four laser blasters. If you vaporize the entire squadron of drones, a new squadron will appear.

As you play, the drones will move faster and faster. The game will continue until all four laser blasters are disabled or a drone reaches the bottom of the arena.

When the game ends, the display will show the level of play that you reached and your final score. The display will then show the four highest scores recorded since the scores were reset. If desired, press and hold down the right button on either controller to reset the scores. Note: If your score is one of the four highest, the display will prompt you to enter a name consisting of three letters or digits. While the line below the first letter is flashing, press the up and down buttons on either controller to select the desired letter or digit. Next, press the right button on either controller and select another letter or digit. Repeat this process to select a third letter or digit. Then, press the right button on either controller again. The display will then show the four highest scores recorded since the scores were reset.

4. Follow your progress with the display.

While you exercise and play the Calorie Destroyer game, the upper left corner of the display will show the elapsed time. In addition, the display will show the game level that you have reached and your current score.

To pause the game, press the Display button. To resume the game, press the Display button repeatedly until the word DESTROYER appears at the top of the display, and then begin pedaling.

5. When you are finished exercising, the console will turn off automatically.

See step 6 on page 13.

MAINTENANCE AND TROUBLESHOOTING

Inspect and properly tighten all parts of the exercise cycle regularly. The exercise cycle can be cleaned with a soft, damp cloth. To prevent damage to the console, keep liquids away from the console and keep the console out of direct sunlight.

TIGHTENING THE PEDALS

For best performance, regularly tighten both pedals.

CONSOLE TROUBLESHOOTING

If the console display becomes dim, the batteries should be replaced. See assembly step 6 on page 8 for replacement instructions. If the console does not display your heart rate when you use the handgrip pulse sensor, see step 5 on page 13.

HOW TO LEVEL THE EXERCISE CYCLE

If the exercise cycle does not sit flat on your floor, turn one or both of the leveling feet until the exercise cycle is level.

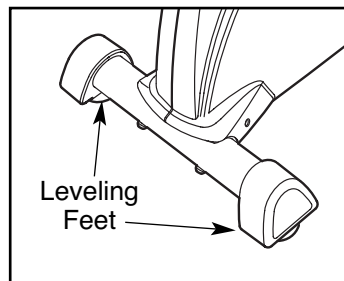

HOW TO ADJUST THE BELT

If the pedals slip while you are pedaling, even while the resistance is adjusted to the highest setting, the belt may need to be adjusted. To adjust the belt, the pedals and side shields must first be removed. Using an adjustable wrench, turn the right pedal counterclockwise and remove it. Then, turn the left pedal counterclockwise and remove it. Remove the screws from the right side shield, and then carefully remove the side shields.

Loosen, but do not remove, the three indicated screws (A). Insert the shaft of a screwdriver downward between the Pulley (22) and the idler (B). Pull the top of the screwdriver toward the rear of the exercise cycle until the Belt (28) is tight. Then, tighten the three screws.

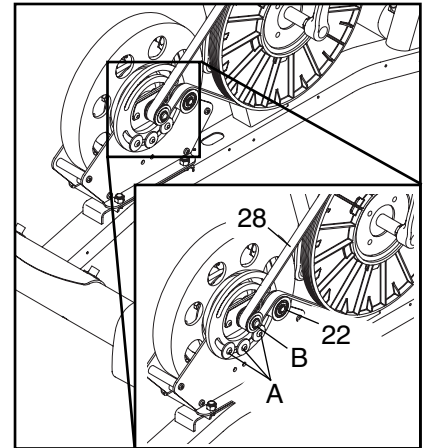

Reattach the side shields, and then reattach the pedals. To attach the pedals, turn the right pedal clockwise and turn the left pedal counterclockwise.

EXERCISE GUIDELINES

⚠ WARNING: Before beginning this or any exercise program, consult your physician. This is especially important for persons over the age of 35 or persons with pre-existing health problems.

The pulse sensor is not a medical device. Various factors may affect the accuracy of heart rate readings. The pulse sensor is intended only as an exercise aid in determining heart rate trends in general.

These guidelines will help you to plan your exercise program. For detailed exercise information, obtain a reputable book or consult your physician. Remember, proper nutrition and adequate rest are essential for successful results.

EXERCISE INTENSITY

Whether your goal is to burn fat or to strengthen your cardiovascular system, exercising at the proper intensity is the key to achieving results. You can use your heart rate as a guide to find the proper intensity level. The chart below shows recommended heart rates for fat burning and aerobic exercise.

165	155	145	140	130	125	115	♥
145	138	130	125	118	110	103	♥
125	120	115	110	105	95	90	♥
<hr/>							
20	30	40	50	60	70	80	

To find the proper intensity level, find your age at the bottom of the chart (ages are rounded off to the nearest ten years). The three numbers listed above your age define your “training zone.” The lowest number is the heart rate for fat burning, the middle number is the heart rate for maximum fat burning, and the highest number is the heart rate for aerobic exercise.

Burning Fat—To burn fat effectively, you must exercise at a low intensity level for a sustained period of time. During the first few minutes of exercise, your body uses *carbohydrate calories* for energy. Only after the first few minutes of exercise does your body begin to use stored *fat calories* for energy. If your goal is to burn fat, adjust the intensity of your exercise until your heart rate is near the lowest number in your training zone. For maximum fat burning, exercise with your heart rate near the middle number in your training zone.

Aerobic Exercise—If your goal is to strengthen your cardiovascular system, you must perform aerobic exercise, which is activity that requires large amounts of oxygen for prolonged periods of time. For aerobic exercise, adjust the intensity of your exercise until your heart rate is near the highest number in your training zone.

WORKOUT GUIDELINES

Warming up—Start with 5 to 10 minutes of stretching and light exercise. A warm-up increases your body temperature, heart rate, and circulation in preparation for exercise.

Training Zone Exercise—Exercise for 20 to 30 minutes with your heart rate in your training zone. (During the first few weeks of your exercise program, do not keep your heart rate in your training zone for longer than 20 minutes.) Breathe regularly and deeply as you exercise—never hold your breath.

Cooling down—Finish with 5 to 10 minutes of stretching. Stretching increases the flexibility of your muscles and helps to prevent post-exercise problems.

EXERCISE FREQUENCY

To maintain or improve your condition, complete three workouts each week, with at least one day of rest between workouts. After a few months of regular exercise, you may complete up to five workouts each week, if desired. Remember, the key to success is to make exercise a regular and enjoyable part of your everyday life.

SUGGESTED STRETCHES

The correct form for several basic stretches is shown at the right. Move slowly as you stretch—never bounce.

1. Toe Touch Stretch

Stand with your knees bent slightly and slowly bend forward from your hips. Allow your back and shoulders to relax as you reach down toward your toes as far as possible. Hold for 15 counts, then relax. Repeat 3 times. Stretches: Hamstrings, back of knees and back.

2. Hamstring Stretch

Sit with one leg extended. Bring the sole of the opposite foot toward you and rest it against the inner thigh of your extended leg. Reach toward your toes as far as possible. Hold for 15 counts, then relax. Repeat 3 times for each leg. Stretches: Hamstrings, lower back and groin.

3. Calf/Achilles Stretch

With one leg in front of the other, reach forward and place your hands against a wall. Keep your back leg straight and your back foot flat on the floor. Bend your front leg, lean forward and move your hips toward the wall. Hold for 15 counts, then relax. Repeat 3 times for each leg. To cause further stretching of the achilles tendons, bend your back leg as well. Stretches: Calves, achilles tendons and ankles.

4. Quadriceps Stretch

With one hand against a wall for balance, reach back and grasp one foot with your other hand. Bring your heel as close to your buttocks as possible. Hold for 15 counts, then relax. Repeat 3 times for each leg. Stretches: Quadriceps and hip muscles.

5. Inner Thigh Stretch

Sit with the soles of your feet together and your knees outward. Pull your feet toward your groin area as far as possible. Hold for 15 counts, then relax. Repeat 3 times. Stretches: Quadriceps and hip muscles.

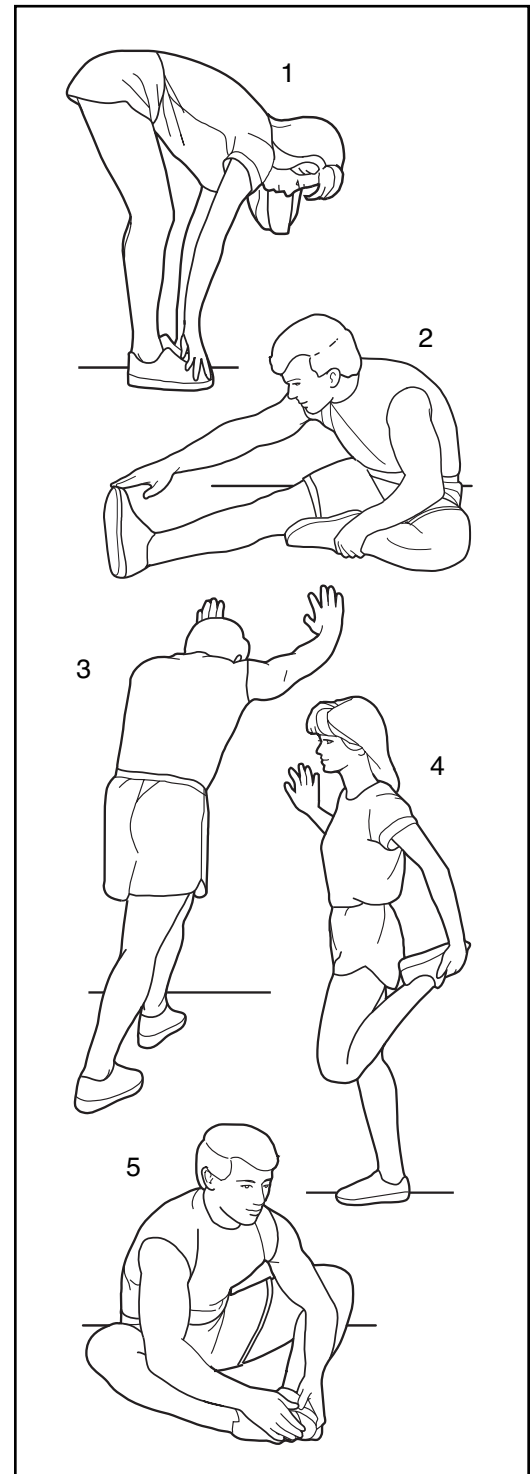

NOTES

NOTES

PART LIST—Model No. RBEX2976.3

R0208A

Key No.	Qty.	Description	Key No.	Qty.	Description
1	1	Frame	34	1	Pulley
2	1	Front Stabilizer	35	1	Pillow Block
3	1	Rear Stabilizer	36	2	M10 Curved Washer
4	1	Left Side Shield	37	1	Right Pedal
5	1	Right Side Shield	38	1	Crank Washer
6	1	Handlebar Post	39	1	Eddy Mech
7	1	Handlebar	40	1	Left Pedal
8	2	Pedal Guard	41	1	Resistance Motor
9	1	Console	42	4	Stabilizer Endcap
10	2	Game Controller	43	1	Idler Arm Assembly
11	1	Seat Post	44	1	Clamp
12	1	Seat	45	2	5/16" x 1" Flange Screw
13	1	Collar	46	3	M10 x 50mm Button Screw
14	2	Side Shield Cover	47	2	M10 x 60mm Button Bolt
15	1	Left Crank Arm	48	4	M10 Nylon Locknut
16	1	Right Crank Arm	49	2	M4 x 10mm Screw
17	2	Wheel	50	1	Reed Switch/Wire
18	1	Water Bottle Holder	51	1	Lower Wire Harness
19	1	Seat Carriage	52	4	M6 x 16mm Screw
20	1	Seat Post Knob	53	8	M6 Nylon Locknut
21	2	Crank Bearing	54	2	Controller Wire
22	1	Idler Pulley	55	1	Upper Wire Harness
23	1	Magnet	56	4	M10 x 85mm Button Screw
24	4	M6 Split Washer	57	4	M8 Nylon Locknut
25	2	Pedal Strap	58	17	M4 x 16mm Screw
26	2	Crank Cover	59	1	M4 x 5mm Screw
27	1	Crank	60	2	M6 x 10mm Screw
28	1	Belt	61	2	Black M10 Curved Washer
29	2	Leveling Foot	62	4	M8 Split Washer
30	2	Grip	63	3	M10 Split Washer
31	1	Seat Knob	64	2	Black M10 x 50mm Button Screw
32	1	Crank Snap Ring	*	—	User's Manual
33	2	M4 x 19mm Screw	*	—	Hex Key

Note: Specifications are subject to change without notice. See the back cover of this manual for information about ordering replacement parts. *These parts are not illustrated.

ORDERING REPLACEMENT PARTS

To order replacement parts, please see the front cover of this manual. To help us assist you, be prepared to provide the following information when contacting us:

- the model number and serial number of the product (see the front cover of this manual)
- the name of the product (see the front cover of this manual)
- the key number and description of the replacement part(s) (see the PART LIST and the EXPLODED DRAWING near the end of this manual)

LIMITED WARRANTY

ICON Health & Fitness, Inc. (ICON) warrants this product to be free from defects in workmanship and material, under normal use and service conditions, for a period of one (1) year from the date of purchase. There is a lifetime warranty on the frame. This warranty extends only to the original purchaser. ICON's obligation under this warranty is limited to replacing or repairing, at ICON's option, the product through one of its authorized service centers. All repairs for which warranty claims are made must be pre-authorized by ICON. If the product is shipped to a service center, freight charges to and from the service center will be the customer's responsibility. For in-home service, the customer will be responsible for a minimal trip charge. This warranty does not extend to any product or damage to a product caused by or attributable to freight damage, abuse, misuse, improper or abnormal usage or repairs not provided by an ICON authorized service center; products used for commercial or rental purposes; or products used as store display models. No other warranty beyond that specifically set forth above is authorized by ICON.

ICON is not responsible or liable for indirect, special or consequential damages arising out of or in connection with the use or performance of the product or damages with respect to any economic loss, loss of property, loss of revenues or profits, loss of enjoyment or use, costs of removal or installation or other consequential damages of whatsoever nature. Some states do not allow the exclusion or limitation of incidental or consequential damages. Accordingly, the above limitation may not apply to you.

The warranty extended hereunder is in lieu of any and all other warranties and any implied warranties of merchantability or fitness for a particular purpose is limited in its scope and duration to the terms set forth herein. Some states do not allow limitations on how long an implied warranty lasts. Accordingly, the above limitation may not apply to you.

This warranty gives you specific legal rights. You may also have other rights which vary from state to state.

ICON HEALTH & FITNESS, INC., 1500 S. 1000 W., LOGAN, UT 84321-9813