

Reebok® X5

INCLINE TRAINER

Model No. RBHK15305.0

Serial No. _____

Find the serial number in the location shown below. Write the serial number in the space above for reference.

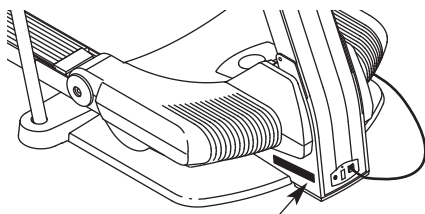

Serial Number Decal

QUESTIONS?

As a manufacturer, we are committed to providing complete customer satisfaction. If you have questions, or if parts are damaged or missing, PLEASE CONTACT OUR CUSTOMER SERVICE DEPARTMENT DIRECTLY.

CALL TOLL-FREE:

1-877-994-4999

Mon.–Fri., 6 a.m.–6 p.m. MST

ON THE WEB:

www.reebokservice.com

USER'S MANUAL

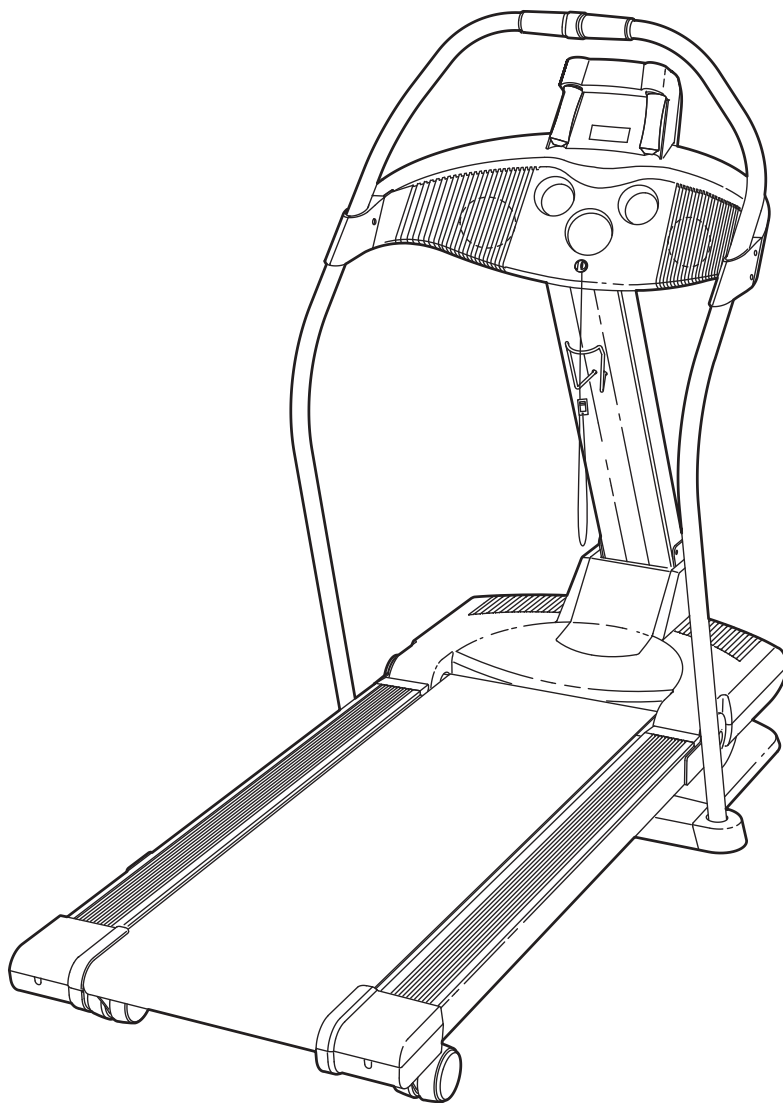

CAUTION

Read all precautions and instructions in this manual before using this equipment. Save this manual for future reference.



Visit our website at

www.reebokhomefitness.com

*new products, prizes,
fitness tips, and much more!*

Reebok® X5

INCLINE TRAINER

TABLE OF CONTENTS

IMPORTANT PRECAUTIONS	3
BEFORE YOU BEGIN	5
ASSEMBLY	6
OPERATION AND ADJUSTMENT	11
HOW TO FOLD AND MOVE THE INCLINE TRAINER	28
TROUBLESHOOTING	30
CONDITIONING GUIDELINES	33
PART LIST	34
ORDERING REPLACEMENT PARTS	Back Cover
LIMITED WARRANTY	Back Cover

Note: An EXPLODED DRAWING is attached in the center of this manual.

IMPORTANT PRECAUTIONS

⚠ WARNING: To reduce the risk of burns, fire, electric shock, or injury to persons, read the following important precautions and information before operating the Incline Trainer.

1. It is the responsibility of the owner to ensure that all users of this Incline Trainer are adequately informed of all warnings and precautions.
2. Use the Incline Trainer only as described.
3. Place the Incline Trainer on a level surface, with at least eight feet of clearance behind it and two feet on each side. Do not place the Incline Trainer on any surface that blocks air openings. To protect the floor or carpet from damage, place a mat under the Incline Trainer.
4. Keep the Incline Trainer indoors, away from moisture and dust. Do not put the Incline Trainer in a garage or covered patio, or near water.
5. Do not operate the Incline Trainer where aerosol products are used or where oxygen is being administered.
6. Keep children under the age of 12 and pets away from the Incline Trainer at all times.
7. The Incline Trainer should not be used by persons weighing more than 300 pounds.
8. Never allow more than one person on the Incline Trainer at a time.
9. Wear appropriate exercise clothes when using the Incline Trainer. Do not wear loose clothes that could become caught in the Incline Trainer. Athletic support clothes are recommended for both men and women. *Always wear athletic shoes. Never use the Incline Trainer with bare feet, wearing only stockings, or in sandals.*
10. When connecting the power cord (see page 11), plug the power cord into a surge suppressor (not included) and plug the surge suppressor into a grounded circuit capable of carrying 15 or more amps. No other appliance should be on the same circuit. Do not use an extension cord.
11. Use only a single-outlet surge suppressor that meets all of the specifications described on page 11. To purchase a surge suppressor, see your local REEBOK dealer or call the toll-free telephone number on the front cover of this manual and order part number 146148, or see your local electronics store.
12. Failure to use a properly functioning surge suppressor could result in damage to the control system of the Incline Trainer. If the control system is damaged, the walking belt may change speed, accelerate, or stop unexpectedly, which may result in a fall and serious injury.
13. Keep the power cord and the surge suppressor away from heated surfaces.
14. Never move the walking belt while the power is turned off. Do not operate the Incline Trainer if the power cord or plug is damaged, or if the Incline Trainer is not working properly. (See BEFORE YOU BEGIN on page 5 if the Incline Trainer is not working properly.)
15. Never start the Incline Trainer while you are standing on the walking belt. Always hold the handrails while using the Incline Trainer.
16. The Incline Trainer is capable of high speeds. Adjust the speed in small increments to avoid sudden jumps in speed.
17. The pulse sensor is not a medical device. Various factors, including the user's movement, may affect the accuracy of heart rate readings. The pulse sensor is intended only as an exercise aid in determining heart rate trends in general.
18. Never leave the Incline Trainer unattended while it is running. Always remove the key, unplug the power cord, and switch the reset/off circuit breaker to the off position when the Incline Trainer is not in use. (See the drawing on page 5 for the location of the reset/off circuit breaker.)
19. Do not attempt to raise, lower, or move the Incline Trainer until it is properly assembled. (See ASSEMBLY on page 6, and HOW TO FOLD AND MOVE THE Incline Trainer on page 28.) You must be able to safely lift 45 pounds (20 kg) to raise, lower, or move the Incline Trainer.
20. Do not change the incline of the Incline Trainer by placing objects under the Incline Trainer.

21. Use the upper body handles only at walking speeds. Using the handles and not holding the handrails may compromise your ability to maintain your balance. Exercises using the handles should be attempted only by experienced users.

22. When folding or moving the Incline Trainer, make sure that the storage latch is fully closed.

23. When using iFIT.com CDs and videos, an electronic “chirping” sound will alert you when the speed and/or incline of the Incline Trainer is about to change. Always listen for the “chirp” and be prepared for speed and/or incline changes. In some instances, the speed and/or incline may change before the personal trainer describes the change.

24. When using iFIT.com CDs and videos, you can manually override the speed and incline settings by pressing the speed and incline buttons. However, when the next “chirp” is heard, the speed and/or incline will change to the next settings of the CD or video program.

25. Always remove iFIT.com CDs and videos from your CD player or VCR when you are not using them.

26. Inspect and properly tighten all parts of the Incline Trainer regularly.

27. Never insert or drop any object into any opening.

28. **DANGER:** Always unplug the power cord immediately after use, before cleaning the Incline Trainer, and before performing the maintenance and adjustment procedures described in this manual. Never remove the motor hood unless instructed to do so by an authorized service representative. Servicing other than the procedures in this manual should be performed by an authorized service representative only.

29. The Incline Trainer is intended for in-home use only. Do not use the Incline Trainer in a commercial, rental, or institutional setting.

⚠ WARNING: Before beginning this or any exercise program, consult your physician. This is especially important for persons over the age of 35 or persons with pre-existing health problems. Read all instructions before using. ICON assumes no responsibility for personal injury or property damage sustained by or through the use of this product.

SAVE THESE INSTRUCTIONS

The decals shown here have been placed on your Incline Trainer. If a decal is missing, or if it is not legible, please call the toll-free telephone number on the front cover of this manual and order a free replacement decal. Apply the decal in the location shown. Note: The decals may not be shown at actual size.

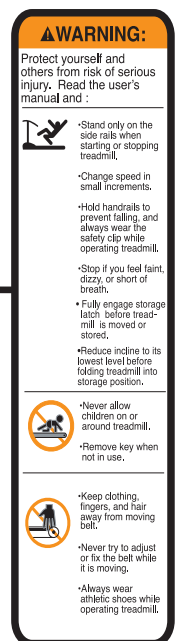
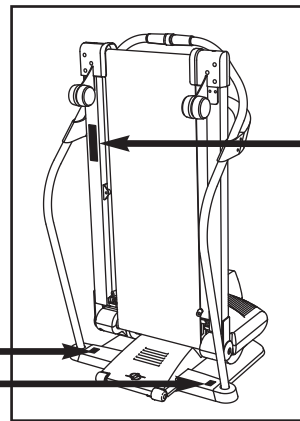
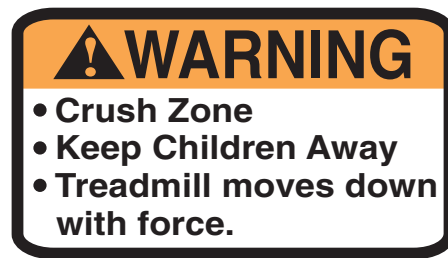

BEFORE YOU BEGIN

Thank you for selecting the revolutionary REEBOK® X5 Incline Trainer. The X5 Incline Trainer offers a selection of features designed to make your workouts at home more enjoyable and effective. And when you're not exercising, the unique X5 Incline Trainer can be folded up, requiring less floor space.

For your benefit, read this manual carefully before you use the Incline Trainer. If you have questions after reading this manual, please see the front cover of this manual. To help us assist you, note the product model number and serial number before calling. The

model number of the Incline Trainer is RBHK15305.0. The serial number can be found on a decal attached to the Incline Trainer (see the front cover of this manual for the location).

To avoid a registration fee for any service needed under warranty, you must register the Incline Trainer at www.reebokservice.com/registration.

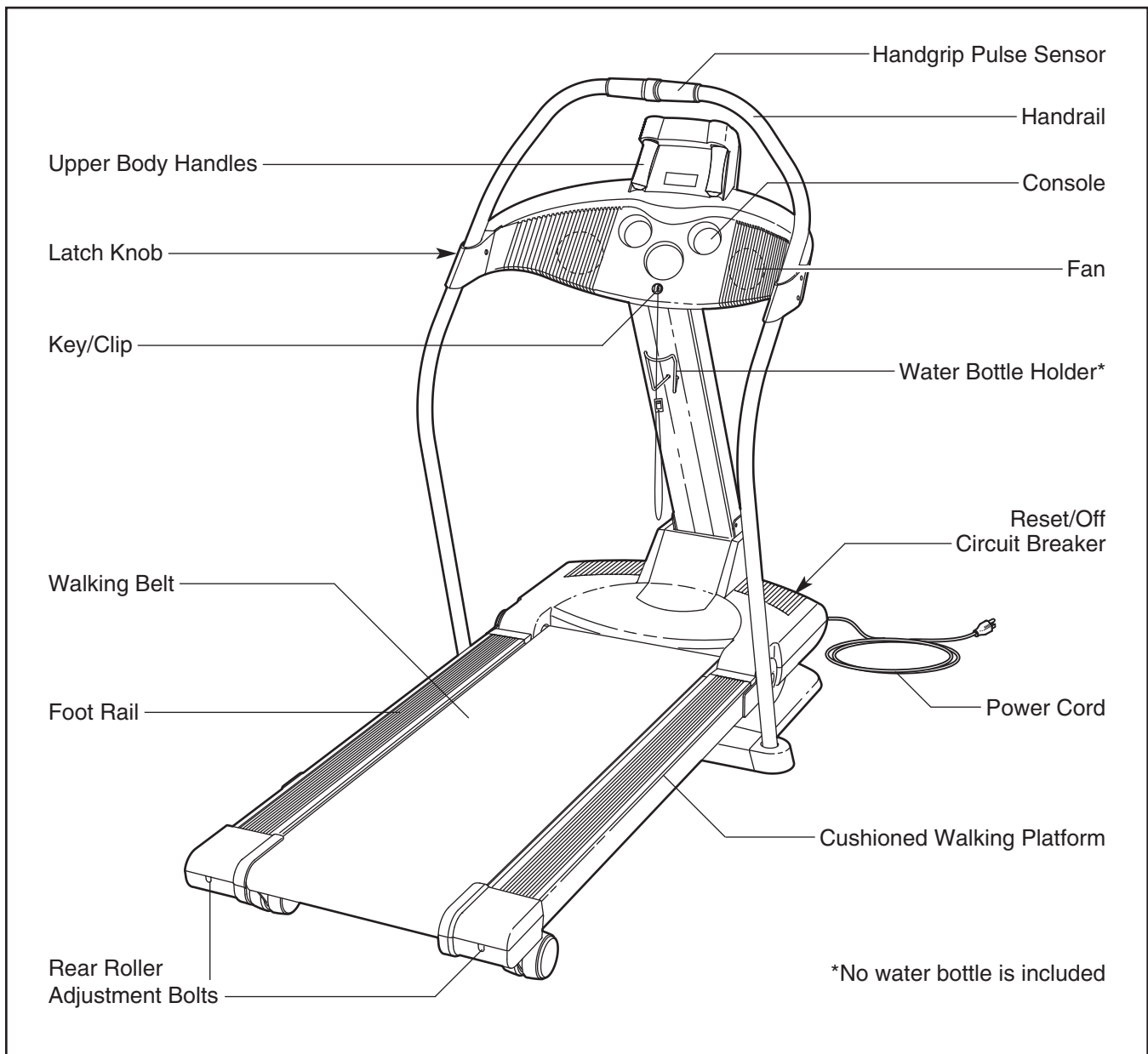

Before reading further, please review the drawing below and familiarize yourself with the labeled parts.



ASSEMBLY

Assembly requires two persons. Set the Incline Trainer in a cleared area and remove all packing materials. **Do not dispose of the packing materials until assembly is completed.**

Note: The underside of the Incline Trainer walking belt is coated with high-performance lubricant. During shipping, a small amount of lubricant may be transferred to the top of the walking belt or the shipping carton. This is a normal condition and does not affect Incline Trainer performance. If there is lubricant on top of the walking belt, simply wipe off the lubricant with a soft cloth and a mild, non-abrasive cleaner.

Assembly requires the included allen wrench  **and your own phillips screwdriver**  **and wire cutters**  . For help identifying the assembly hardware, see the hardware drawings below.

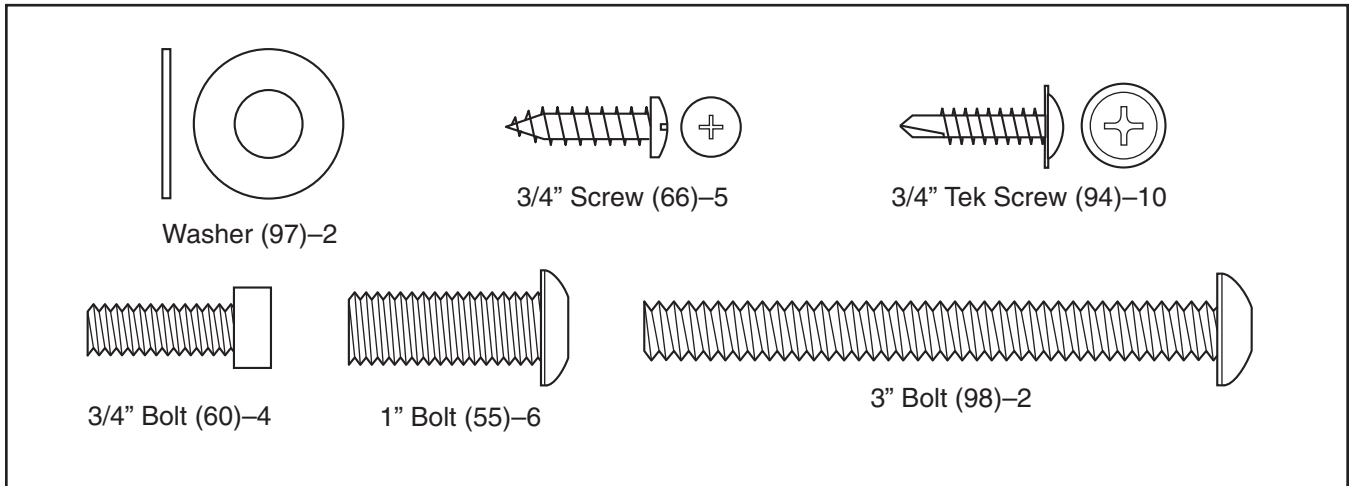

1. To protect the floor during assembly, place a sheet of cardboard under the pallet as shown.

With the help of a second person, carefully raise the Upright (110) to the position shown.

While the other person holds the Upright (110), firmly tighten two 1" Bolts (55) into the lower end of the Upright and the Upright Base (96).

Insert the Power Cord (85) through the hole in the Upright Cover (115). Press the Upright Cover onto the Upright (110). **Make sure that the Upright Cover is securely held by the clips along the opening in the Upright.** Tighten a 3/4" Screw (66) into the lower end of the Upright Cover. **Be careful not to over tighten the 3/4" Screw.**

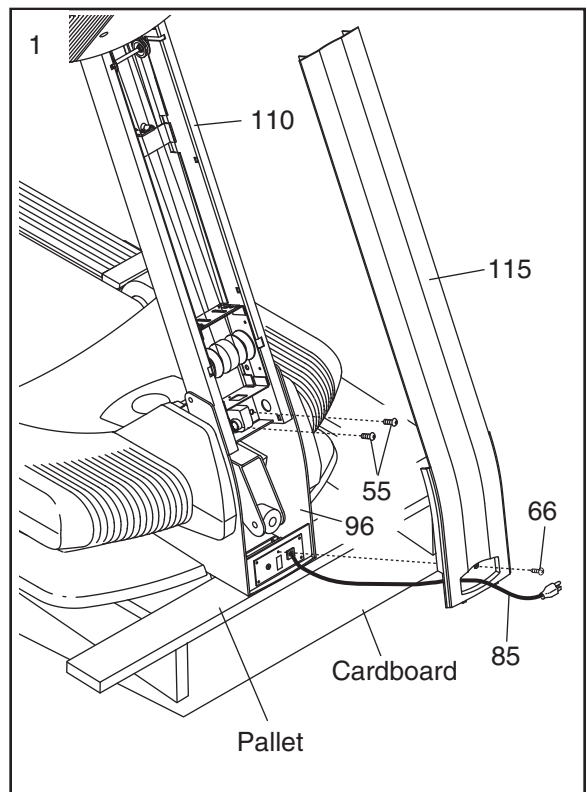

2. Insert a Handrail (67) into the Upper Handrail (68) as shown. The lower end of the Handrail should sit on the Base Hood (105) as shown. (Note: It may be necessary to twist the Handrail as you insert it. It may also be necessary to loosen the two Screws [3] several turns.) Next, tighten two 3/4" Screws (66) into the Handrail. **If you loosened the Screws, retighten them.**

Attach the other Handrail (not shown) to the left side of the Incline Trainer in the same way.

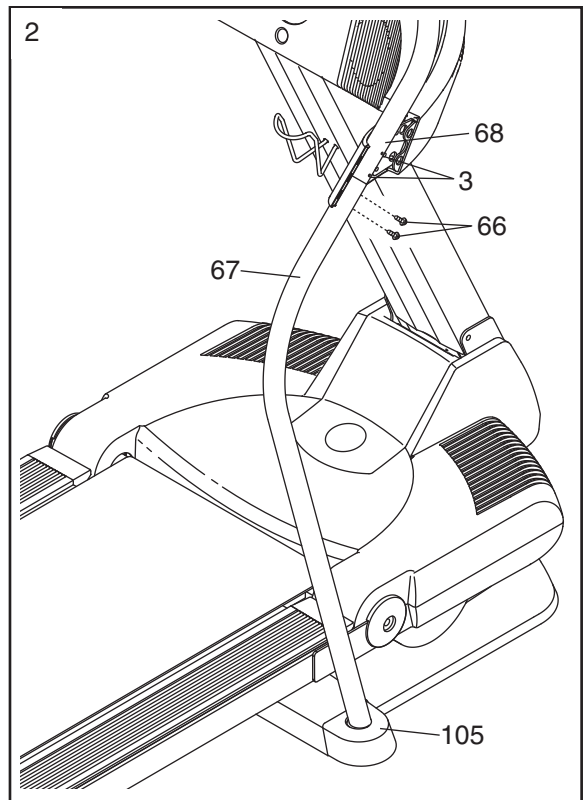

3. Interlock the tabs on the Right Outer Cover (88) with the tabs on the Right Inner Cover (65). Attach the Right Outer Cover with two 3/4" Bolts (60) as shown

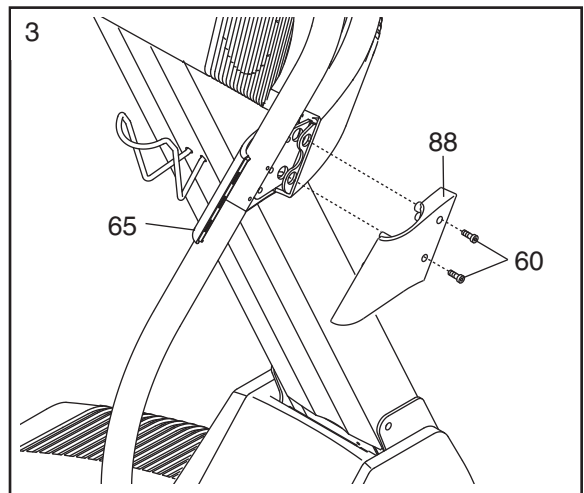

4. Interlock the tabs on the Left Outer Cover (61) with the tabs on the Left Inner Cover (106). Attach the Left Outer Cover with two 3/4" Bolts (60).

Remove the knob from the pin. **Make sure that the collar and the spring are on the pin.** Insert the threaded end of the pin through the hole in the Left Inner Cover (106) and the hole in the Left Outer Cover (61). Tighten the knob back onto the pin.

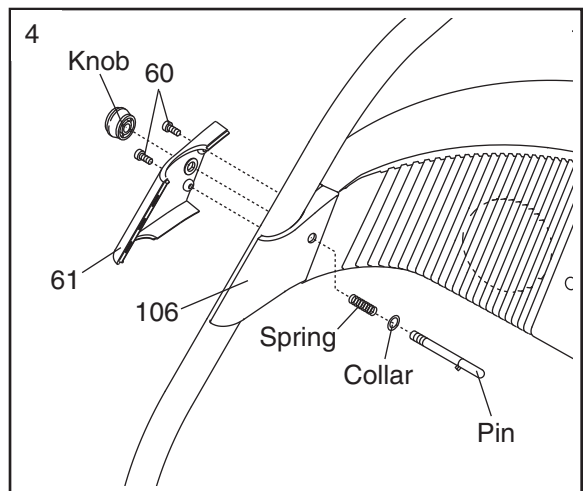

5. With the help of a second person, carefully tip the Upright Base (96) to the position shown.

Remove the four indicated bolts and washers attaching the pallet to the Upright Base (96). Discard the pallet, bolts, and washers.

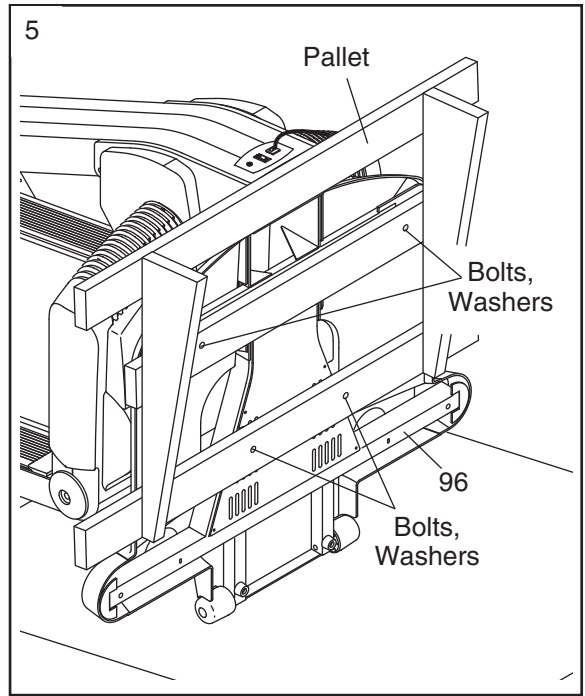

6. Attach the Upright Base Pad (103) and the six Base Pads (93) to the bottom of the Upright Base (96) with ten 3/4" Tek Screws (94) as shown.

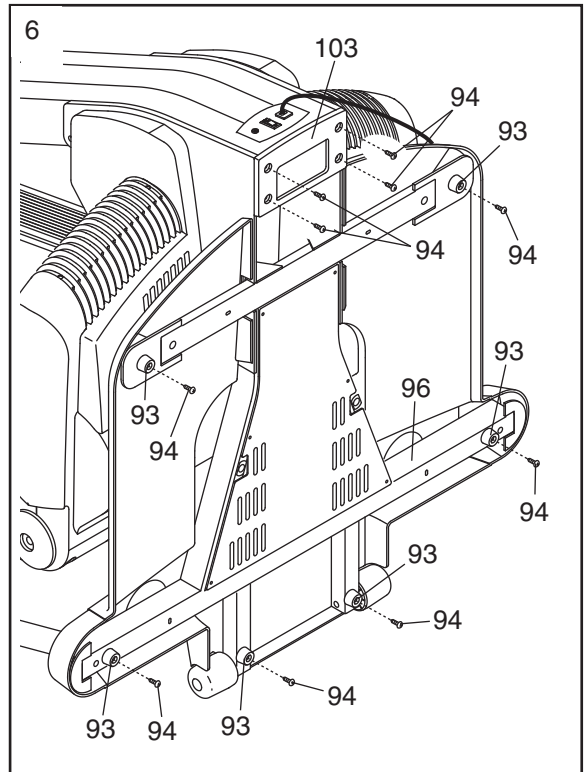

7. Tighten two 3" Bolts (98) with two Washers (97) into the bottom of the Upright Base (96) and the Handrails (67) (only one Handrail is shown). Firmly tighten the Bolts.

With the help of a second person, carefully tip the Upright Base (96) so it is flat on the floor. Remove the cardboard from underneath the Upright Base.

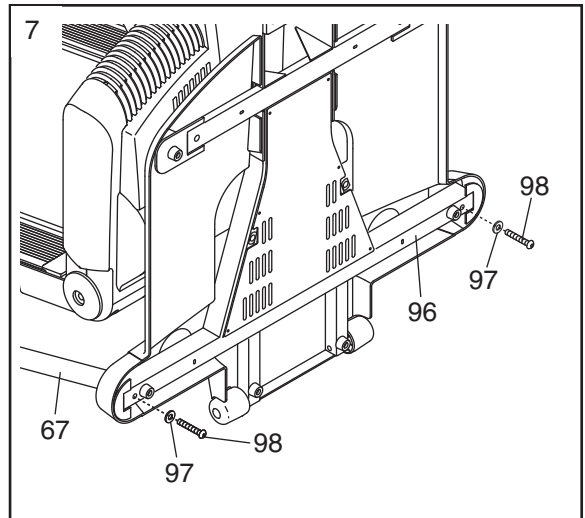

8. Fold the Incline Trainer to the storage position (see HOW TO FOLD THE INCLINE TRAINER FOR STORAGE on page 28).

Slide the Right Wheel Bracket (59) into the slot in the Right Rear Endcap (57). Align the holes in the Bracket with the holes in the Frame (43). Attach the Bracket to the Frame with two 1" Bolts (55).

Attach the Left Wheel Bracket (not shown) in the same way.

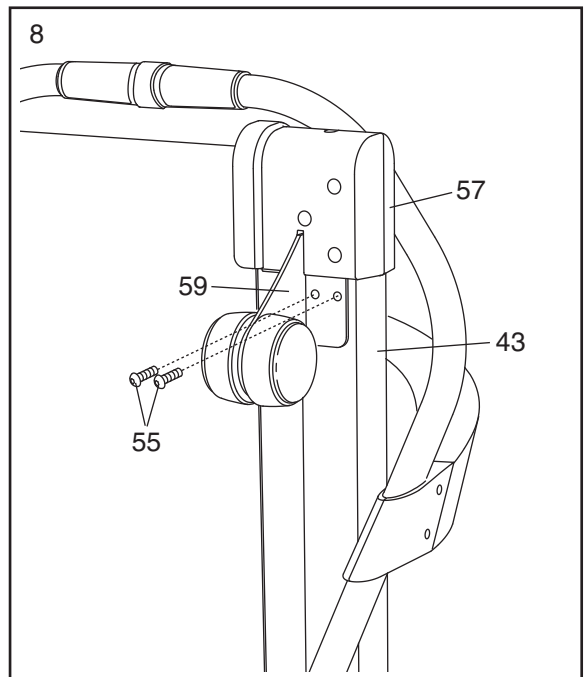

9. **Make sure that all parts are properly tightened before you use the Incline Trainer.** Keep the included allen wrench in a secure place. The allen wrench is used to adjust the walking belt (see page 31). **To protect the floor or carpet from damage, place a mat under the Incline Trainer.**

If you purchase the optional chest pulse sensor (see page 27), follow the steps below to install the receiver included with the chest pulse sensor.

1. **Make sure that the power cord is unplugged.**

Look under the Console Back (69) and locate the Access Door (112) on the indicated side of the Incline Trainer. Remove the Access Door Screw (72) and the Access Door.

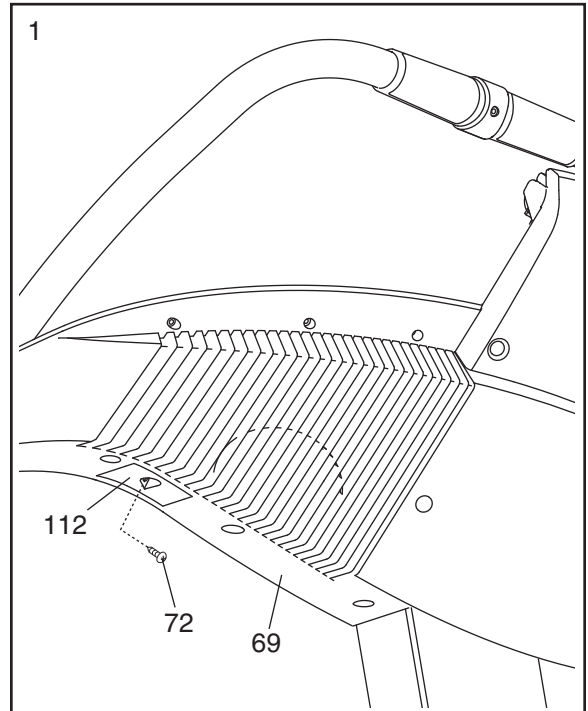

2. Connect the wire on the receiver (A) to the indicated wire extending from the console. **Hold the receiver so the small cylinder is oriented as shown and is facing the console.** Attach the receiver to the plastic posts on the Access Door (112) with the two included small screws.

3. See step 1 on page 9. **Make sure that no wires are pinched,** and reattach the Access Door (112) to the Console Back (69) with the Access Door Screw (72).

Discard the other wires included with the receiver.

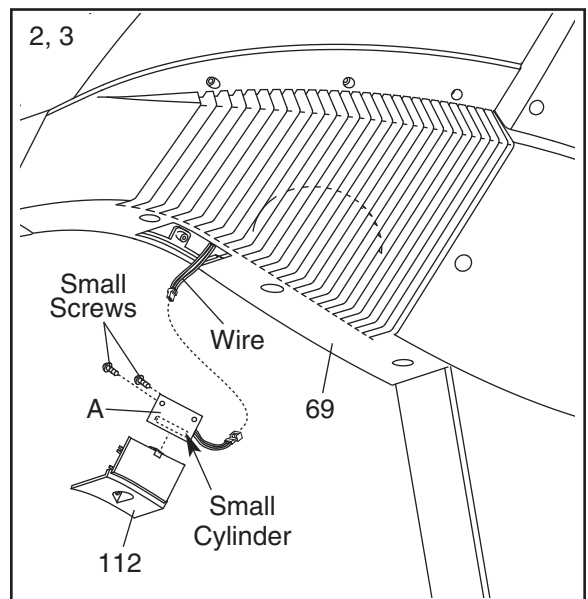

OPERATION AND ADJUSTMENT

THE PRE-LUBRICATED WALKING BELT

Your Incline Trainer features a walking belt coated with high-performance lubricant. **IMPORTANT: Never apply silicone spray or other substances to the walking belt or the walking platform. Such substances will deteriorate the walking belt and cause excessive wear.**

HOW TO PLUG IN THE POWER CORD

⚠ DANGER: Improper connection of the equipment-grounding conductor can result in an increased risk of electric shock. Check with a qualified electrician or serviceman if you are in doubt as to whether the product is properly grounded. Do not modify the plug provided with the product—if it will not fit the outlet, have a proper outlet installed by a qualified electrician.

Your Incline Trainer, like any other type of sophisticated electronic equipment, can be seriously damaged by sudden voltage changes in your home's power. Voltage surges, spikes, and noise interference can result from weather conditions or from other appliances being turned on or off. **To decrease the possibility of your Incline Trainer being damaged, always use a surge suppressor with your Incline Trainer (see drawing 1 at the right). To purchase a surge suppressor, see your local REEBOK dealer or call the toll-free telephone number on the front cover of this manual and order part number 146148, or see your local electronics store.**

Use only a single-outlet surge suppressor that is UL 1449 listed as a transient voltage surge suppressor (TVSS). The surge suppressor must have a UL suppressed voltage rating of 400 volts or less and a minimum surge dissipation of 450 joules. The surge suppressor must be electrically rated for 120 volts AC and 15 amps. There must be a monitoring light on the surge suppressor to indicate whether it is functioning properly. Failure to use a properly functioning surge suppressor could result in damage to the control system of the Incline Trainer. If the control system is damaged, the walking belt may change speed, accelerate or stop unexpectedly, which may result in a fall and serious injury.

This product must be grounded. If it should malfunction or break down, grounding provides a path of least resistance for electric current to reduce the risk of elec-

tric shock. This product is equipped with a cord having an equipment-grounding conductor and a grounding plug. **Plug the power cord into a surge suppressor, and plug the surge suppressor into an appropriate outlet that is properly installed and grounded in accordance with all local codes and ordinances. Important: The Incline Trainer is not compatible with GFCI-equipped outlets.**

This product is for use on a nominal 120-volt circuit, and has a grounding plug that looks like the plug illustrated in drawing 1 below. A temporary adapter that looks like the adapter illustrated in drawing 2 may be used to connect the surge suppressor to a 2-pole receptacle as shown in drawing 2 if a properly grounded outlet is not available.

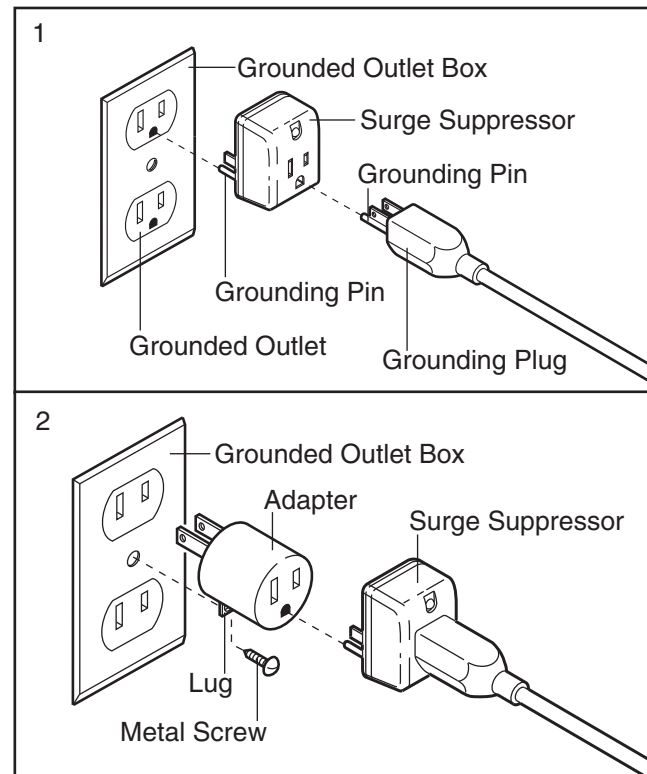

The temporary adapter should be used only until a properly grounded outlet (drawing 1) can be installed by a qualified electrician.

The green-colored rigid ear, lug, or the like extending from the adapter must be connected to a permanent ground such as a properly grounded outlet box cover. Whenever the adapter is used it must be held in place by a metal screw. **Some 2-pole receptacle outlet box covers are not grounded. Contact a qualified electrician to determine if the outlet box cover is grounded before using an adapter.**

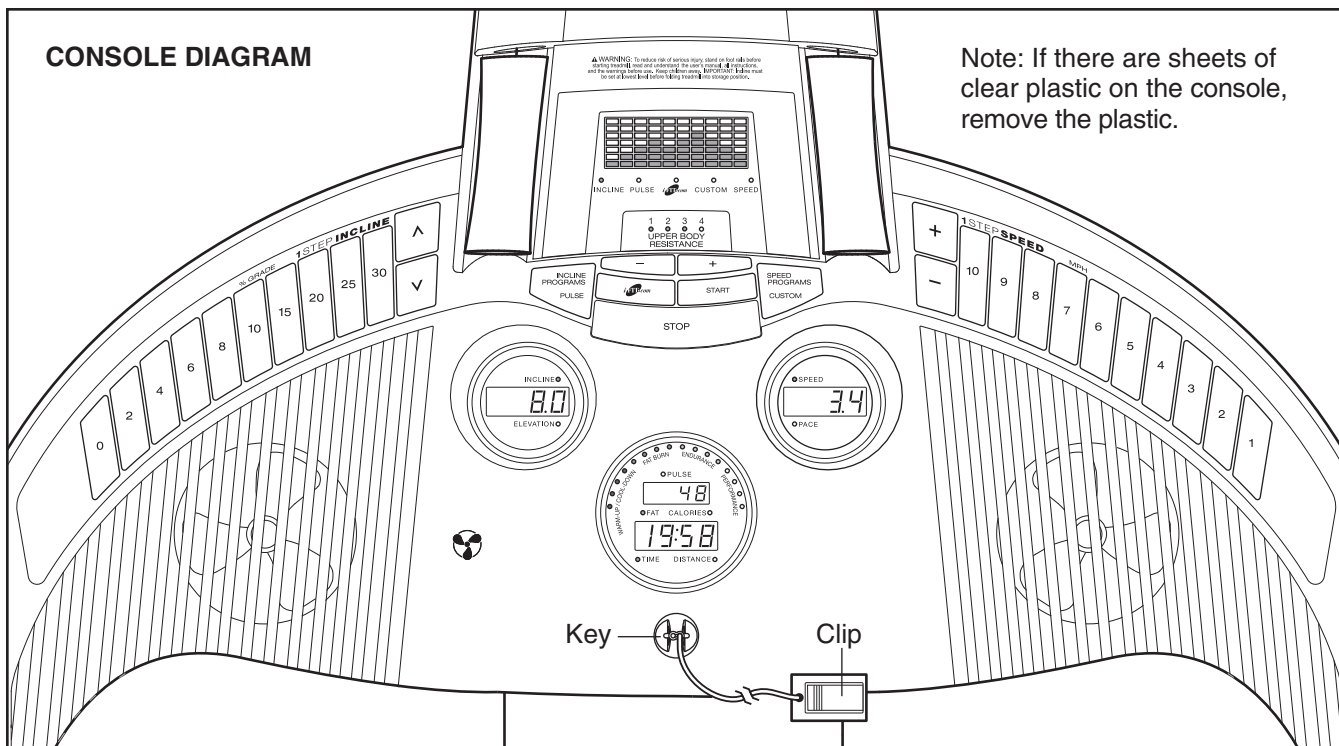

FEATURES OF THE CONSOLE

The advanced console offers an impressive array of features designed to help you get the most from your exercise. When the manual mode of the console is selected, the speed and incline of the Incline Trainer can be changed with the touch of a button. As you exercise, the console will provide continuous exercise feedback. You can even measure your heart rate using the handgrip pulse sensor or the optional chest pulse sensor (see page 27).

The console also offers 5 speed programs and 10 incline programs. Each program automatically controls the speed and incline of the Incline Trainer as it guides you through an effective workout. You can even create your own custom workout programs and store them in memory for future use.

In addition, the console offers four pulse programs that automatically adjust the speed and incline of the Incline Trainer to keep your heart rate near a target level while you exercise. Note: The pulse programs require the use of the optional chest pulse sensor.

The console also features iFIT.com interactive technology. Having iFIT.com technology is like having a personal trainer in your home. Using the included audio cable, you can connect the Incline Trainer to your home

stereo, portable stereo, computer, or VCR and play special iFIT.com CD and video programs (iFIT.com CDs and videocassettes are available separately). iFIT.com CD and video programs automatically control the speed and incline of the Incline Trainer as a personal trainer coaches you through every step of your workout. High-energy music provides added motivation. **To purchase iFIT.com CDs or videocassettes, call the toll-free telephone number on the front cover of this manual.**

With the Incline Trainer connected to your computer, you can also go to our Web site at www.iFIT.com and access iFIT.com programs directly from the internet. **See www.iFIT.com for more information.**

To use the manual mode of the console, follow the steps beginning on page 13. **To use a speed program or an incline program**, see page 16. **To create and use a custom program**, see pages 18 and 19. **To use a pulse program**, see page 20. **To use an iFIT.com CD or video program**, see page 24. **To use an iFIT.com program directly from our Web site**, see page 26.

Note: During the first few minutes that the Incline Trainer is used, observe the alignment of the walking belt, and align it if necessary (see page 31).

CAUTION: Before operating the console, read the following precautions.

- Do not stand on the walking belt when turning on the power.
- Always wear the clip (see the drawing on page 12) while operating the Incline Trainer.
- Adjust the speed in small increments to avoid sudden jumps in speed.
- The pulse sensor is not a medical device. Various factors, including the user's movement, may affect the accuracy of heart rate readings. The pulse sensor is intended only as an exercise aid in determining heart rate trends in general.
- To reduce the possibility of electric shock, keep the console dry. Avoid spilling liquids on the console.

HOW TO TURN ON THE POWER

1 Plug in the power cord.

See page 11.

2 Move the reset/off circuit breaker to the reset position.

Locate the reset/off circuit breaker on the Incline Trainer near the power cord. Make sure that the circuit breaker is in the reset position.

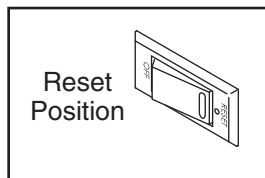

3 Attach the clip to the waistband of your clothes.

Stand on the foot rails of the Incline Trainer. Find the clip attached to the key (see the drawing on page 12), and slide the clip securely onto the waistband of your clothes. Next, insert the key into the console. **Test the clip by carefully taking a few steps backward until the key is pulled from the console. If the key is not pulled from the console, adjust the position of the clip as needed.** Then, remove the key from the console.

HOW TO USE THE MANUAL MODE

1 Insert the key into the console.

See HOW TO TURN ON THE POWER at the left.

2 Select the manual mode.

When the key is inserted, the manual mode will be selected. If a program has been selected, press the iFIT.com button

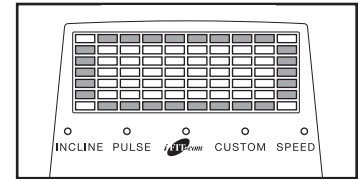

once or twice until a track appears in the matrix but the iFIT.com indicator is **not** lit.

3 Start the walking belt.

To start the walking belt, press the Start button, the Speed + button, or one of the 1-Step Speed buttons.

If the Start button or the Speed + button is pressed, the walking belt will begin to move at 1 mph. As you exercise, change the speed of the walking belt as desired by pressing the Speed + and – buttons. Each time a button is pressed, the speed setting will change by 0.1 mph; if a button is held down, the speed setting will change in increments of 0.5 mph.

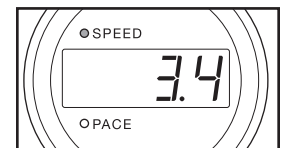

If one of the 1-Step Speed buttons is pressed, the walking belt will gradually increase in speed until it reaches the selected speed setting. Note: It may take a few seconds for the walking belt to reach the selected speed setting. **The Incline Trainer is designed so that the walking belt cannot move at high speed while the Incline Trainer is at a high incline level. Therefore, when you increase the speed, the incline may automatically decrease.**

To stop the walking belt, press the Stop button. The time will begin to flash in the Time/Distance display. To restart the walking belt, press the Start button, the Speed + button, or one of the 1-Step Speed buttons.

Note: Before the Incline Trainer is used, a short break-in period is required. Adjust the speed to 10 mph, let the Incline Trainer run for ten minutes, and then press the stop button.

4 Change the incline of the Incline Trainer as desired.

To change the incline of the Incline Trainer, press the Incline increase and decrease buttons. Each time a button is pressed, the incline will change by 0.5%. To change the incline setting quickly, press the 1-step Incline buttons. Note: It may take a few seconds for the Incline Trainer to reach the selected incline setting. **The Incline Trainer is designed so that it cannot be adjusted to a high incline level while the walking belt is moving at high speed. Therefore, when you increase the incline, the speed may automatically decrease.**



5 Follow your progress with the matrix and the displays.

The matrix—

When the manual mode or the iFIT.com mode is selected, the matrix will display a track representing 1/4 mile. As you exercise, the indicators around the track will light in succession until the entire track is lit. The track will then darken and the indicators will again begin to light in succession.

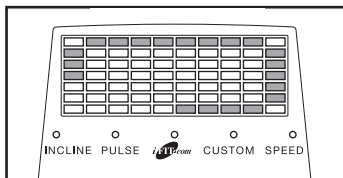

The Training Zone display—

As you exercise, the Training Zone display will show the approximate intensity level of your exercise. For example, if five to eight indicators are lit, the Training zone display shows that your intensity level is ideal for fat burning.

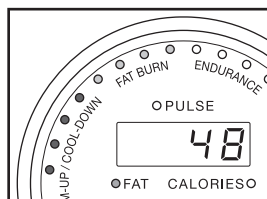

Incline/Elevation display—

This display shows the incline level of the Incline Trainer and the number of vertical feet you have climbed. The display will alternate between one value and the other every few seconds, as shown by the indicators above and below the display. Note: Each time the incline level changes, the display will show the incline level.



Fat Calories/Calories/Pulse display—This display shows the approximate numbers of *fat calories* and *calories* you have burned (see FAT BURNING on page 33). The display will alternate between one value and the other every few seconds, as shown by the indicators below the display. The display will also show your heart rate when you use the handgrip pulse sensor or the optional chest pulse sensor.



Time/Distance display—

When the manual mode or the iFIT.com mode is selected, this display will show the elapsed time and the distance that you have walked or run. When a program is selected, the display will show the time remaining in the program and the distance that you have walked or run. The display will alternate between one value and the other every few seconds, as shown by the indicators below the display.



Speed/Pace display—

This display shows the speed of the walking belt and your walking or running pace, in minutes per mile. The display will alternate between one value and the other every few seconds, as shown by the indicators above and below the display. Note: Each time the incline level changes, the display will show the incline level.

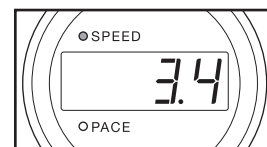

Note: The console can display speed and distance in either miles or kilometers. The word "METRIC" will light below the Time/Distance display when speed and distance are displayed in kilometers. To change the unit of measurement, first hold down the Stop button while inserting the key into the console. An "E" for English miles or an "M" for metric kilometers will appear in the Speed/Pace display. Press the Speed + button to change the unit of measurement. When the desired unit of measurement is selected, remove the key and then reinsert it. **Note: For simplicity, all instructions in this manual refer to miles.**

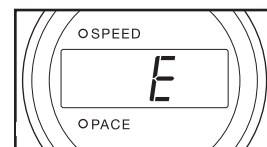

To reset the displays, press the Stop button, remove the key, and then reinsert the key.

6 Measure your heart rate if desired.

To use the optional chest pulse sensor, see the instructions included with the chest pulse sensor. To use the handgrip pulse sensor, see the instructions below. Note: If there are sheets of clear plastic on the metal contacts on the handgrip pulse sensor, remove the plastic. If you use the optional chest pulse sensor and the handgrip pulse sensor at the same time, the console will not display your heart rate accurately.

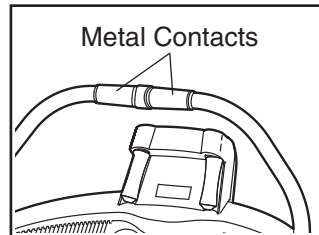

To measure your heart rate, **stand on the foot rails** and place your hands on the metal contacts on the handgrip pulse sensor. Your palms must be resting on the contacts closest to you, and your fingers must be touching the contacts on the opposite side of the handgrip pulse sensor—**avoid moving your hands**. When your pulse is detected, the Pulse indicator above the Fat Calories/Calories/Pulse display will light, one or two dashes (— —) will appear in the display, and then your heart rate will be shown. **For the most accurate heart rate reading, continue to hold the contacts for about 15 seconds.**

7 Turn on the fans if desired.

To turn on the fans at low speed, press the button near the left fan. To turn on the fans at high speed, press the button a second time. To turn off the fans, press the button a third time. Note: Any time that the walking belt is stopped for a few minutes, the fans will automatically turn off.

8 Use the upper body handles if desired.

CAUTION: Do not use the upper body handles until you are comfortable using the Incline Trainer.

To use the upper body handles, hold one handle in each hand, and pull the handles as you swing your arms naturally at your sides. Practice this motion until it feels comfortable.

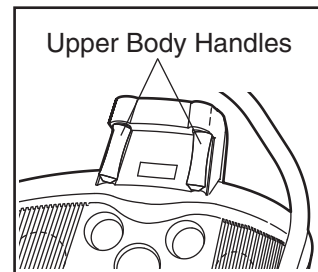

To increase or decrease the resistance of the upper body handles, press the + and – buttons below the matrix.

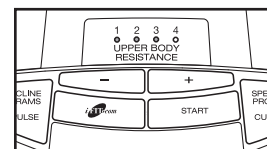

Indicators above the buttons will light to show which of the four resistance levels is selected.

9 When you are finished exercising, stop the walking belt and remove the key.

Step onto the foot rails, press the Stop button, and adjust the incline of the Incline Trainer to the lowest level. **The incline must be at the lowest level when the Incline Trainer is raised to the storage position or the Incline Trainer will be damaged.** Next, remove the key from the console and put it in a secure place. **Note: If the displays and indicators on the console remain lit after the key is removed, the console is in the “demo” mode. See page 27 and turn off the demo mode.**

When you are finished using the Incline Trainer, switch the reset/off circuit breaker to the off position and unplug the power cord.

HOW TO USE A SPEED PROGRAM OR AN INCLINE PROGRAM

The console offers 5 speed programs and 10 incline programs. All 15 programs automatically control the speed and the incline of the Incline Trainer as they guide you through effective workouts. Speed programs regulate the intensity of your exercise primarily by varying the speed of the walking belt, although they also vary the incline; incline programs primarily vary the incline, although they also vary the speed.

Follow the steps below to use a speed program or an incline program.

1 Insert the key into the console.

See HOW TO TURN ON THE POWER on page 13.

2 Select a speed program or an incline program.

To select a speed program, press the Speed Programs/Custom button repeatedly. As each speed program is selected, the Speed indicator will light and a profile of the speed settings of the selected program will scroll across the matrix.

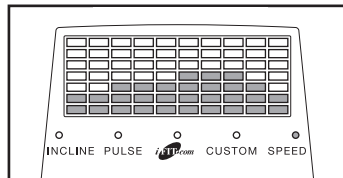

To select an incline program, press the Incline Programs/Pulse button repeatedly. As each incline program is selected, the Incline indicator will light and a profile of the incline settings of the selected program will scroll across the matrix.

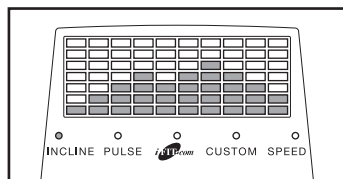

For a few seconds after a speed program or an incline program is selected, the maximum speed setting for the program will flash in the Speed/Pace display, and the maximum incline setting for the program will flash in the Incline/Elevation display. The Time/Distance display will show how long the program will last.

3 Press the Start button or the Speed + button to start the program.

A moment after the button is pressed, the Incline Trainer will automatically adjust to the first speed and incline settings for the program. Hold the handrails and begin walking.

Each program is divided into one-minute segments. One speed setting and one incline setting are programmed for each segment. Note: The same speed setting and/or incline setting may be programmed for two or more consecutive segments.

If a speed program is selected, the speed setting for the first segment will be shown in the flashing Current Segment column of the matrix. (The

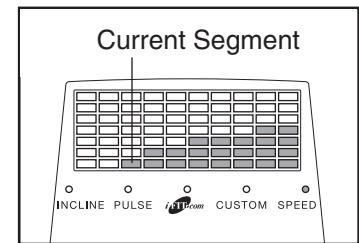

The incline settings will not be shown in the matrix.) The speed settings for the next seven segments will be shown in the columns to the right. **If an incline program is selected,** the incline setting for the first segment will be shown in the flashing Current Segment column of the matrix. (The speed settings will not be shown in the matrix.) The incline settings for the next seven segments will be shown in the columns to the right.

When only three seconds remain in the first segment of the program, both the Current Segment column and the column to the right will flash and a series of tones will sound. If the speed and/or incline of the Incline Trainer is about to change, the Speed/Pace display and/or the Incline/Elevation display will flash to alert you. When the first segment ends, *all speed settings or incline settings will move one column to the left*. The setting for the second segment will then be shown in the flashing Current Segment column and the Incline Trainer will automatically adjust to the speed and incline settings for the second segment. Note: If all of the indicators in the Current Segment column are lit after the settings have moved to the left, *all settings will move downward* so that only the highest lit indicators appear in the matrix. If some of the indicators in the Current Segment column are not lit when the settings move to the left again, all settings will move back up.

The program will continue until the setting for the last segment is shown in the Current Segment column and the last segment ends. The walking belt will then slow to a stop.

If the speed or incline setting is too high or too low at any time during the program, you can manually override the setting by pressing the Speed or Incline buttons. **However, when the next segment begins, the speed and/or incline will automatically change if a different setting is programmed for the next segment.**

To stop the program temporarily, press the Stop button. The time will begin to flash in the Time/Distance display. To restart the program, press the Start button or the Speed + button. The walking belt will begin to move at 1 mph. When the next segment of the program begins, the Incline Trainer will automatically adjust to the speed and incline settings for the next segment. To end the program, press the Stop button, remove the key, and then reinsert the key.

4 Follow your progress with the displays.

See step 5 on page 14.

5 Measure your heart rate if desired.

See step 6 on page 15.

6 Turn on the fans if desired.

See step 7 on page 15.

7 Use the upper body handles if desired.

See step 8 on page 15.

8 When you are finished exercising, remove the key.

Step onto the foot rails and make sure that the incline of the Incline Trainer is at the lowest level.

The incline must be at the lowest level when the Incline Trainer is raised to the storage position. Next, remove the key from the console and put it in a secure place. **Note: If the displays and indicators on the console remain lit after the key is removed, the console is in the “demo” mode. See page 27 and turn off the demo mode.**

When you are finished using the Incline Trainer, switch the reset/off circuit breaker to the off position and unplug the power cord.

HOW TO CREATE A CUSTOM PROGRAM

If desired, you can create your own custom workout programs and store them in memory for future use. Up to four different programs can be stored at the same time.

Follow the steps below to create a custom program.

1 Insert the key into the console.

See HOW TO TURN ON THE POWER on page 13.

2 Select one of the custom programs.

To select a custom program, press the Speed Programs/Custom button repeatedly. As each custom program is selected, the Custom indicator will light and a profile of the speed settings of the selected program will scroll across the matrix. **Note: If the custom program has not yet been defined, only three columns of indicators will be lit in the matrix. If more than three columns of indicators are lit, see HOW TO USE A CUSTOM PROGRAM on page 19.**

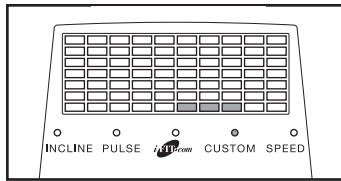

3 Press the Start button or the Speed + button and program the desired speed and incline settings.

A moment after the button is pressed, the walking belt will begin to move. Hold the handrails and begin walking.

See the matrix. Each custom program is divided into one-minute segments. One speed setting and one incline setting can be programmed for each segment. The speed setting for the first segment will be shown in the flashing Current

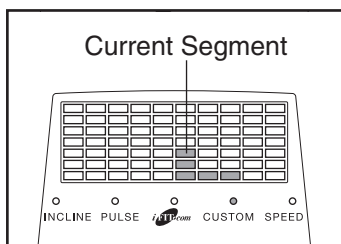

Segment column of the matrix. (The incline settings will not be shown in the matrix.) To program a speed setting and an incline setting for the first segment, simply adjust the speed and incline of the Incline Trainer as desired by pressing the Speed and Incline buttons. Every few times a Speed button is pressed, an additional indicator will light or darken in the Current Segment column.

During the last three seconds of the first segment, both the Current Segment column and the column to the right will flash, a series of tones will sound, and the Speed/Pace display and the Incline/Elevation display will flash. When the first segment ends, the current speed setting and the current incline setting will be saved in memory, and *all speed settings in the matrix will move one column to the left*. The speed setting for the second segment will then be shown in the flashing Current Segment column. Program a speed setting and an incline setting for the second segment as described above.

Continue programming speed and incline settings for as many segments as desired; custom programs can have up to forty segments. When you are finished with your workout, press the Stop button twice. The speed and incline settings that you have programmed and the number of segments that you have programmed will then be saved in memory.

4 Follow your progress with the displays.

See step 5 on page 14.

5 Measure your heart rate if desired.

See step 6 on page 15.

6 Turn on the fans if desired.

See step 7 on page 15.

7 Use the upper body handles if desired.

See step 8 on page 15.

8 When you are finished exercising, remove the key.

See step 8 on page 17.

HOW TO USE A CUSTOM PROGRAM

Follow the steps below to use a custom program.

1 Insert the key into the console.

See HOW TO TURN ON THE POWER on page 13.

2 Select one of the custom programs.

To select a custom program, press the Speed Programs/ Custom button repeatedly. As each custom program is selected, the Custom indicator will light and a profile of the speed settings of the selected program will scroll across the matrix. **Note: If only three columns of indicators are lit in the matrix, see HOW TO CREATE A CUSTOM PROGRAM on page 18.**

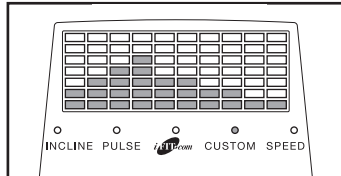

For a few seconds after a custom program is selected, the maximum speed setting for the program will flash in the Speed/Pace display, and the maximum incline setting for the program will flash in the Incline/Elevation display. The Time/Distance display will show how long the program will last.

3 Press the Start button or the Speed + button to start the program.

A moment after the button is pressed, the Incline Trainer will automatically adjust to the first speed and incline settings that you programmed previously. Hold the handrails and begin walking.

Each program is divided into several one-minute segments. One speed setting and one incline setting are programmed for each segment.

The speed setting for the first segment will be shown in the flashing Current Segment column of the matrix. (The incline settings are not shown in the matrix.) The speed settings for the

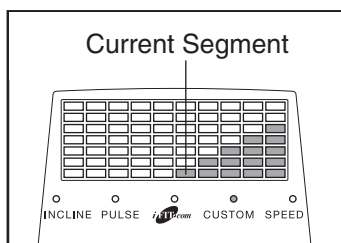

next several segments will be shown in the columns to the right.

When only three seconds remain in the first segment of the program, both the Current Segment column and the column to the right will flash and a tone will sound. If the speed and/or incline of the Incline Trainer is about to change, the Speed/Pace display and/or the Incline/Elevation display will flash to alert you, and three tones will sound. When the first segment ends, *all speed settings will move one column to the left*. The speed setting for the second segment will then be shown in the flashing Current Segment column and the Incline Trainer will automatically adjust to the speed and incline settings for the second segment.

The program will continue until the speed setting for the last segment is shown in the Current Segment column and the last segment ends. The walking belt will then slow to a stop.

If desired, you can redefine the program while using it. **To change the speed or incline setting for the current segment**, simply press the Speed or Incline buttons. When the current segment ends, the new setting will be saved in memory. **To increase the length of the program**, first wait until the program ends. Then, press the Start button and program speed and incline settings for as many additional segments as desired. When you have added as many segments as desired, press the Stop button twice. **To decrease the length of the program**, press the Stop button twice at any time before the program ends.

To stop the program at any time, press the Stop button. The time will begin to flash in the Time/Distance display. To restart the program, press the Start button or the Speed + button. The walking belt will begin to move at 1 mph. When the next segment of the program begins, the Incline Trainer will automatically adjust to the speed and incline settings for the next segment.

4 Follow your progress with the displays.

See step 5 on page 14.

5 Measure your heart rate if desired.

See step 6 on page 15.

6 Turn on the fans if desired.

See step 7 on page 15.

7 Use the upper body handles if desired.

See step 8 on page 15.

8 When you are finished exercising, remove the key.

See step 8 on page 17.

HOW TO USE A PULSE PROGRAM

⚠ CAUTION: If you have heart problems, or if you are over 60 years of age and have been inactive, do not use the pulse programs. If you are taking medication regularly, consult your physician to find whether the medication will affect your exercise heart rate.

The four pulse programs automatically adjust the speed and incline of the Incline Trainer to keep your heart rate near a target level while you exercise.

Follow the steps below to use a pulse program.

1 Put on the optional chest pulse sensor.

See the instructions included with the chest pulse sensor.

2 Insert the key into the console.

See HOW TO TURN ON THE POWER on page 13.

3 Select a pulse program.

To select a pulse program, press the Incline Programs/Pulse button repeatedly. As each pulse program is selected, the Pulse indicator will light and a profile of the heart rate settings of the selected program will scroll across the matrix.

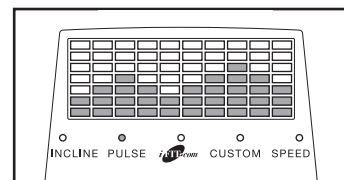

4 Enter your age.

When a pulse program is selected, the word "AGE" will appear in the Fat Calories/Calories/Pulse display and the current age setting will begin to flash in the Time/Distance display. If you have already entered your age, simply press the Start button (the program will not start at this time). If you have not entered your age, press the + and – buttons below the matrix to enter your age, and then press the Start button.

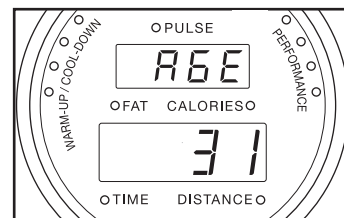

5 Enter a maximum speed setting.

After you have entered your age, the letters “SPd” will appear in the Fat Calories/Calories/Pulse display and the maximum speed setting of the program will begin to flash in the Time/Distance display. If desired, press the + and – buttons below the matrix to change the maximum speed setting.

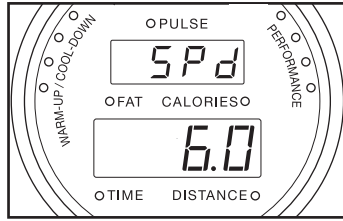

6 Press the Start button or the Speed + button to start the program.

A moment after the button is pressed, the Incline Trainer will automatically adjust to the first speed and incline settings for the program. Hold the handrails and begin walking.

Each pulse program is divided into several one-minute segments. (The Time/Distance display will show how long the program will last.) One target heart rate setting is programmed for each segment. Note: The same target heart rate setting may be programmed for two or more consecutive segments.

The target heart rate setting for the first segment will be shown in the flashing Current Segment column of the matrix. The target heart rate settings for the next seven segments will be shown in the columns to the right.

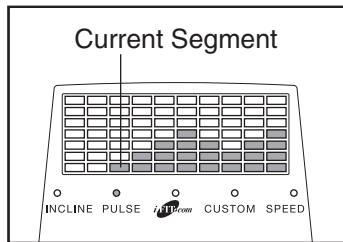

When only three seconds remain in the first segment of the program, both the Current Segment column and the column to the right will flash and a series of tones will sound. In addition, the Speed/Pace display and the Incline/Elevation display will flash. When the first segment ends, *all target heart rate settings will move one column to the left*. The target heart rate setting for the second segment will then be shown in the flashing Current Segment column.

During each segment, the console will compare your heart rate to the target heart rate. If your heart rate is too far below or above the target heart rate, the speed of the walking belt will auto-

matically increase or decrease to bring your heart rate closer to the target heart rate. If the speed reaches the maximum speed setting of the program (see step 5 on this page) and your heart rate is still too far below the current target heart rate, the incline of the Incline Trainer will also increase to bring your heart rate closer to the target heart rate.

The program will continue in this way until the target heart rate setting for the last segment is shown in the Current Segment column and the last segment ends. The walking belt will then slow to a stop.

If the speed or incline setting is too high or too low at any time during the program, you can adjust the setting with the Speed or Incline buttons. However, each time the console compares your heart rate to the target heart rate, the speed and/or incline of the Incline Trainer may automatically change to bring your heart rate closer to the target heart rate.

If your pulse is not detected during the program, the letters “PLS” will flash in the Fat Calories/Calories/Pulse display and the speed and incline of the Incline Trainer may automatically decrease until your pulse is detected. If this occurs, see the instructions included with the optional chest pulse sensor.

To stop the program at any time, press the Stop button. The time will begin to flash in the Time/Distance display. To restart the program, press the Start button or the Speed + button. The walking belt will begin to move at 1 mph. When the console compares your heart rate to the target heart rate, the speed and/or incline of the Incline Trainer will automatically change to bring your heart rate closer to the target heart rate.

7 Follow your progress with the displays.

See step 5 on page 14.

8 Turn on the fans if desired.

See step 7 on page 15.

9 Use the upper body handles if desired.

See step 8 on page 15.

10 When you are finished exercising, remove the key.

See step 8 on page 17.

HOW TO CONNECT THE INCLINE TRAINER TO YOUR CD PLAYER, VCR, OR COMPUTER

To use **iFIT.com CDs**, the Incline Trainer must be connected to your portable CD player, portable stereo, home stereo, or computer with CD player. See pages 22 and 23 for connecting instructions. To use **iFIT.com videocassettes**, the Incline Trainer must be connected to your VCR. See page 24 for connecting instructions. To use **iFIT.com programs directly from our Web site**, the Incline Trainer must be connected to your computer. See page 23.

HOW TO CONNECT YOUR PORTABLE CD PLAYER

Note: If your CD player has separate **LINE OUT** and **PHONES** jacks, see instruction A below. If your CD player has only one jack, see instruction B.

- A. Plug one end of the audio cable into the jack on the front of the Incline Trainer near the power cord. Plug the other end of the cable into the **LINE OUT** jack on your CD player. Plug your headphones into the **PHONES** jack.

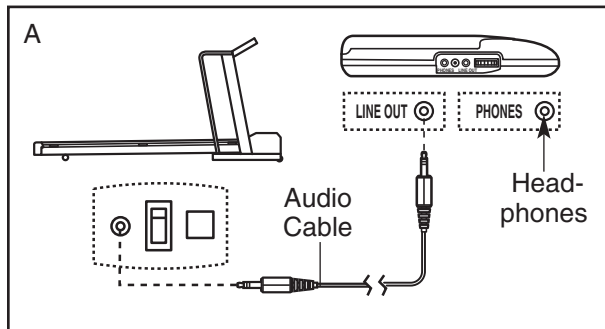

- B. Plug one end of the audio cable into the jack on the front of the Incline Trainer near the power cord. Plug the other end of the cable into a 3.5mm Y-adapter (available at electronics stores). Plug the Y-adapter into the **PHONES** jack on your CD player. Plug your headphones into the other side of the Y-adapter.

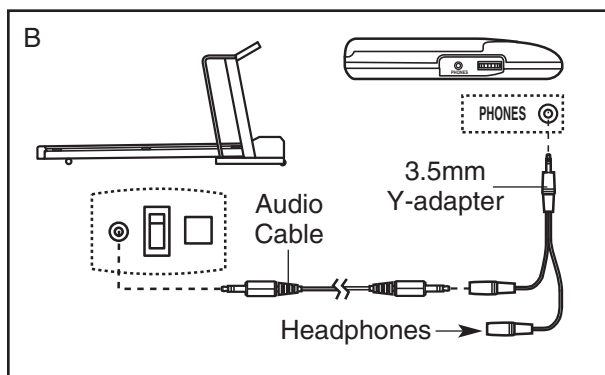

HOW TO CONNECT YOUR PORTABLE STEREO

Note: If your stereo has an **RCA-type AUDIO OUT** jack, see instruction A below. If your stereo has a **3.5mm LINE OUT** jack, see instruction B. If your stereo has only a **PHONES** jack, see instruction C.

- A. Plug one end of the audio cable into the jack on the front of the Incline Trainer near the power cord. Plug the other end into the included adapter. Plug the adapter into an **AUDIO OUT** jack on your stereo.

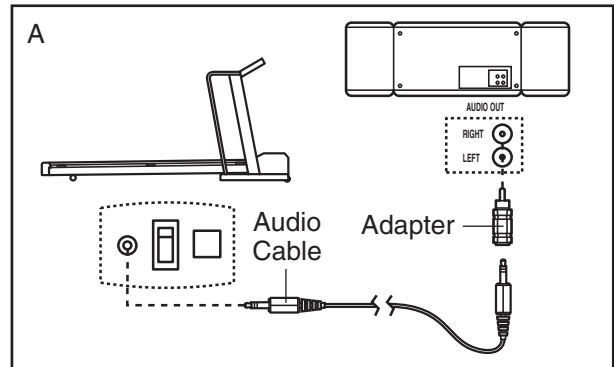

- B. Plug one end of the audio cable into the jack on the front of the Incline Trainer near the power cord. Plug the other end of the cable into the **LINE OUT** jack on your stereo.

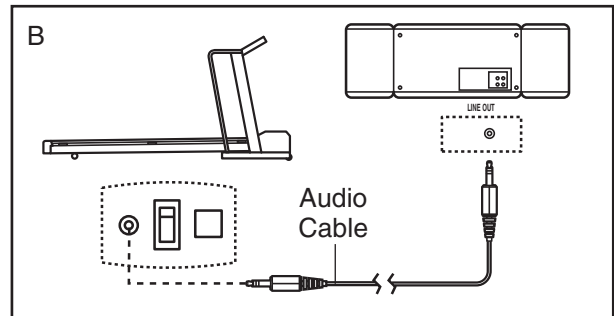

- C. Plug one end of the audio cable into the jack on the front of the Incline Trainer near the power cord. Plug the other end of the cable into a 3.5mm Y-adapter (available at electronics stores). Plug the Y-adapter into the **PHONES** jack on your stereo. Plug your headphones into the other side of the Y-adapter.

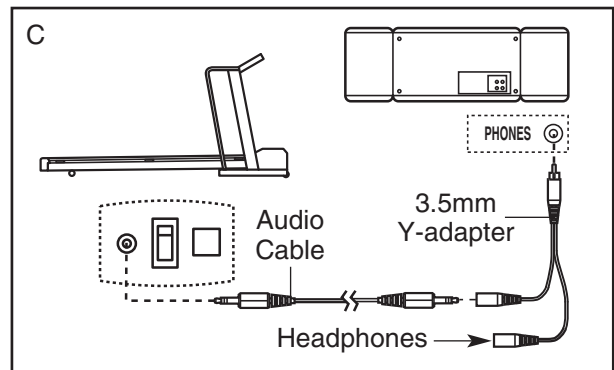

HOW TO CONNECT YOUR HOME STEREO

Note: If your stereo has an unused **LINE OUT** jack, see instruction **A** below. If the **LINE OUT** jack is being used, see instruction **B**.

- A. Plug one end of the audio cable into the jack on the front of the Incline Trainer near the power cord. Plug the other end of the cable into the included adapter. Plug the adapter into the **LINE OUT** jack on your stereo.

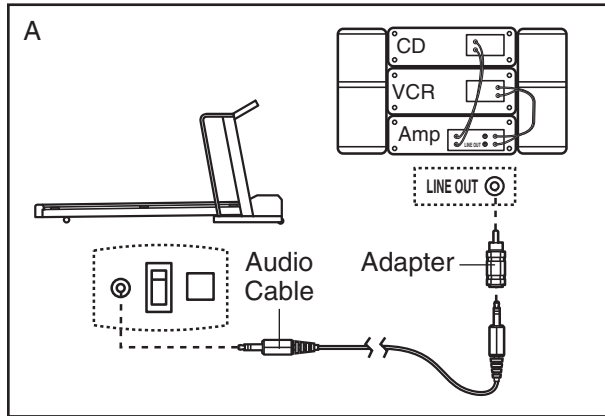

- B. Plug one end of the audio cable into the jack on the front of the Incline Trainer near the power cord. Plug the other end of the cable into the included adapter. Plug the adapter into an RCA Y-adapter (available at electronics stores). Next, remove the wire that is currently plugged into the **LINE OUT** jack on your stereo and plug the wire into the unused side of the RCA Y-adapter. Plug the RCA Y-adapter into the **LINE OUT** jack on your stereo.

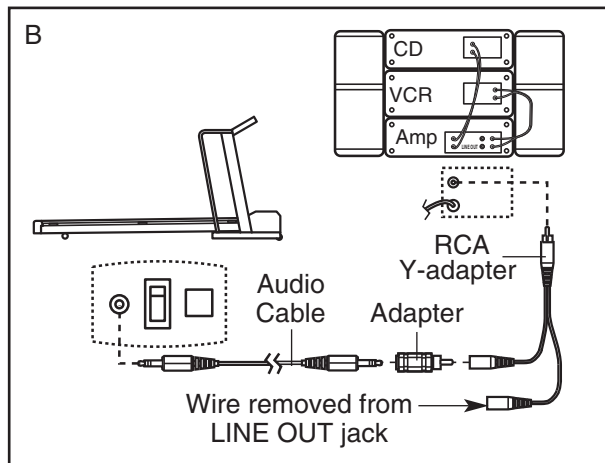

HOW TO CONNECT YOUR COMPUTER

Note: If your computer has a 3.5mm **LINE OUT** jack, see instruction **A**. If your computer has only a **PHONES** jack, see instruction **B**.

- A. Plug one end of the audio cable into the jack on the front of the Incline Trainer near the power cord. Plug the other end of the cable into the **LINE OUT** jack on your computer.

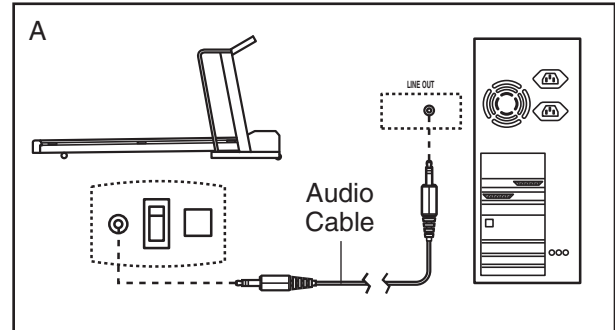

- B. Plug one end of the audio cable into the jack on the front of the Incline Trainer near the power cord. Plug the other end of the cable into a 3.5mm Y-adapter (available at electronics stores). Plug the Y-adapter into the **PHONES** jack on your computer. Plug your headphones or speakers into the other side of the Y-adapter.

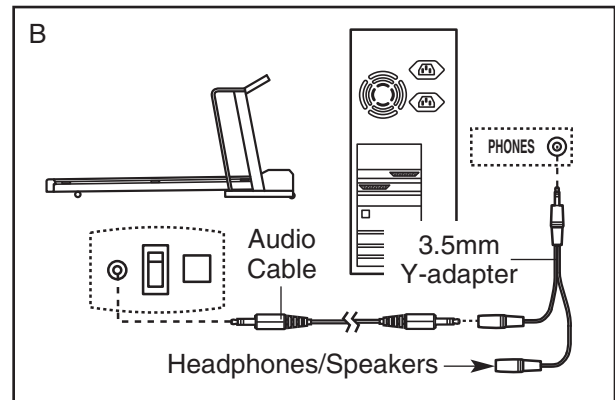

HOW TO CONNECT YOUR VCR

Note: If your VCR has an unused AUDIO OUT jack, see instruction A below. If the AUDIO OUT jack is being used, see instruction B. If you have a TV with a built-in VCR, see instruction B. If your VCR is connected to your home stereo, see **HOW TO CONNECT YOUR HOME STEREO** on page 23.

- A. Plug one end of the audio cable into the jack on the front of the Incline Trainer near the power cord. Plug the other end of the cable into the included adapter. Plug the adapter into the AUDIO OUT jack on your VCR.

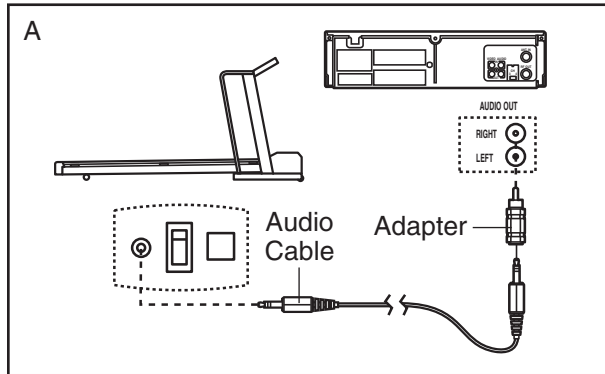

- B. Plug one end of the audio cable into the jack on the front of the Incline Trainer near the power cord. Plug the other end of the cable into the included adapter. Plug the adapter into an RCA Y-adapter (available at electronics stores). Next, remove the wire that is currently plugged into the AUDIO OUT jack on your VCR and plug the wire into the unused side of the RCA Y-adapter. Plug the RCA Y-adapter into the AUDIO OUT jack on your VCR.

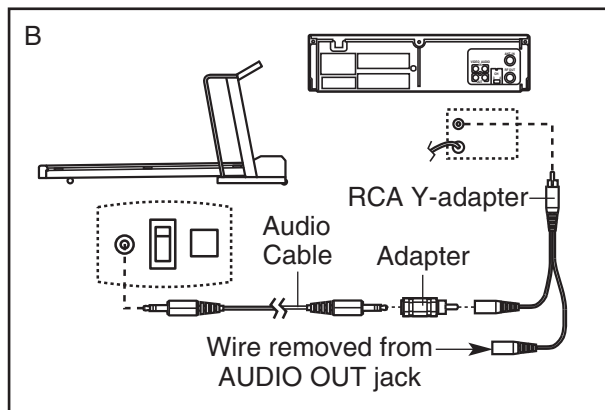

HOW TO USE AN iFIT.COM CD OR VIDEO PROGRAM

To use iFIT.com CDs or videocassettes, the Incline Trainer must be connected to your portable CD player, portable stereo, home stereo, computer with CD player, or VCR. See **HOW TO CONNECT THE INCLINE TRAINER TO YOUR CD PLAYER, VCR, OR COMPUTER** on pages 22 to 24. **Note: To purchase iFIT.com CDs or videocassettes, call the toll-free telephone number on the front cover of this manual.**

Follow the steps below to use an iFIT.com CD or video program.

1 Insert the key into the console.

See **HOW TO TURN ON THE POWER** on page 13.

2 Select the iFIT.com mode.

To use an iFIT.com CD or video program, first press the iFIT.com button. The iFIT.com indicator will light.

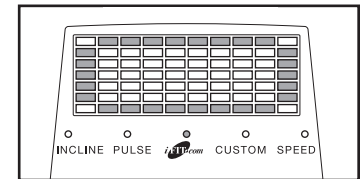

3 Insert the iFIT.com CD or videocassette.

If you are using an iFIT.com CD, insert the CD into your CD player. If you are using an iFIT.com videocassette, insert the videocassette into your VCR.

4 Press the PLAY button on your CD player or VCR.

A moment after the button is pressed, your personal trainer will begin guiding you through your workout. Simply follow your personal trainer's instructions. Note: If the time is flashing in the Time/Distance display, press the Start button or the Speed + button on the console. The Incline Trainer will not respond to a CD or video program while the time is flashing in the Time/Distance display.

During the CD or video program, an electronic “chirping” sound will alert you when the speed and/or incline of the Incline Trainer is about to change. **CAUTION: Always listen for the “chirp” and be prepared for speed and/or incline changes. In some instances, the speed and/or incline may change before the personal trainer describes the change.**

If the speed or incline settings are too high or too low, you can manually override the settings at any time by pressing the Speed or Incline buttons on the console. However, **when the next “chirp” is heard, the speed and/or incline will change to the next settings of the CD or video program.**

To stop the walking belt at any time, press the Stop button on the console. The time will begin to flash in the Time/Distance display. To restart the walking belt, press the Start button or the Speed + button. After a moment, the walking belt will begin to move at 1 mph. **When the next “chirp” is heard, the speed and/or incline will change to the next settings of the CD or video program.**

When the CD or video program ends, the walking belt will stop and the time will begin to flash in the Time/Distance. Note: To use another CD or video program, press the Stop button or remove the key and go to step 1 on page 24.

Note: If the speed and/or incline of the Incline Trainer does not change when a “chirp” is heard:

- **Make sure that the iFIT.com indicator is lit and that the time is not flashing in the Time/Distance display. If the time is flashing, press the Start button or the Speed + button on the console.**

- **Adjust the volume of your CD player or VCR. If the volume is too high or too low, the console may not detect the program signals.**
- **Make sure that the audio cable is properly connected, that it is fully plugged in, and that it is not wrapped around a power cord.**
- **If you are using your portable CD player and the CD skips, set the CD player on the floor or another flat surface instead of on the console.**
- **See the instructions on page 32.**

5 Follow your progress with the displays.

See step 5 on page 14.

6 Measure your heart rate if desired.

See step 6 on page 15.

7 Turn on the fans if desired.

See step 7 on page 15.

8 Use the upper body handles if desired.

See step 8 on page 15.

9 When you are finished exercising, remove the key.

See step 8 on page 17.

CAUTION: Always remove iFIT.com CDs and videocassettes from your CD player or VCR when you are finished using them.

HOW TO USE A PROGRAM DIRECTLY FROM OUR WEB SITE

To use programs from our Web site, the Incline Trainer must be connected to your home computer. See HOW TO CONNECT YOUR COMPUTER on page 23. In addition, you must have an internet connection and an internet service provider. A list of specific system requirements is found on our Web site.

Follow the steps below to use a program from our Web site.

1 Insert the key into the console.

See HOW TO TURN ON THE POWER on page 13.

2 Select the iFIT.com mode.

To use an iFIT.com program from our Web site, first press the iFIT.com button. The iFIT.com indicator will light.

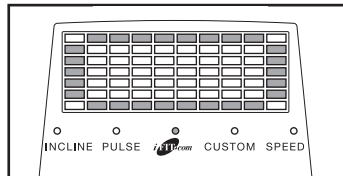

3 Go to your computer and start an internet connection.

4 Start your web browser, if necessary, and go to our Web site at www.iFIT.com.

5 Follow the desired links on our Web site to select a program.

Read and follow the on-line instructions for using a program.

6 Follow the on-line instructions to start the program.

When you start the program, an on-screen countdown will begin.

7 Return to the Incline Trainer and stand on the foot rails. Find the clip attached to the key and slide the clip securely onto the waistband of your clothes.

When the on-screen countdown ends, the program will begin and the walking belt will begin to move. Hold the handrails, step onto the walking belt, and begin walking. During the program, an electronic

“chirping” sound will alert you when the speed and/or incline of the Incline Trainer is about to change. **CAUTION: Always listen for the “chirp” and be prepared for speed and/or incline changes.**

If the speed or incline settings are too high or too low, you can manually override the settings at any time by pressing the Speed or Incline buttons on the console. **However, when the next “chirp” is heard, the speed and/or incline will change to the next settings of the program.**

To stop the walking belt at any time, press the Stop button on the console. The time will begin to flash in the Time/Distance display. To restart the walking belt, press the Start button or the Speed + button. After a moment, the walking belt will begin to move at 1 mph. **When the next “chirp” is heard, the speed and/or incline will change to the next settings of the program.**

When the program ends, the walking belt will stop and the time will begin to flash in the Time/Distance display. Note: To use another program, press the Stop button and go to step 5.

Note: If the speed or incline of the Incline Trainer does not change when a “chirp” is heard, make sure that the iFIT.com indicator is lit and that the time is not flashing in the Time/Distance display. In addition, make sure that the audio cable is properly connected, that it is fully plugged in, and that it is not wrapped around a power cord.

8 Follow your progress with the displays.

See step 5 on page 14.

9 Measure your heart rate if desired.

See step 6 on page 15.

10 Turn on the fans if desired.

See step 7 on page 15.

11 Use the upper body handles if desired.

See step 8 on page 15.

12 When you are finished exercising, remove the key.

See step 8 on page 17.

THE INFORMATION MODE/DEMO MODE

The console features an information mode that keeps track of the total number of miles that the walking belt has moved and the total number of hours that the Incline Trainer has been operated. The information mode also allows you to switch the console from miles to kilometers. In addition, the information mode allows you to turn on and turn off the demo mode.

To select the information mode, hold down the Stop button while inserting the key into the console. When the information mode is selected, the following information will be shown:

The Incline/Elevation display will show the total number of miles or kilometers that the walking belt has moved.



The Time/Distance display will show the total number of hours that the Incline Trainer has been used.



An "E" for English miles or an "M" for metric kilometers will appear in the Speed/Pace display. Press the Speed + button to change the unit of measurement.

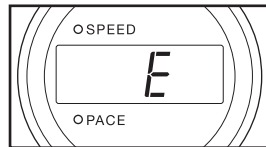

IMPORTANT: The Fat Calories/Calories/Pulse display should be blank. If a "d" appears in the display, the console is in the "demo" mode. This mode is intended to be used only when an Incline Trainer is displayed in a store. When the console is in the demo mode, the power cord can be plugged in, the key can be removed from the console, and the displays and indicators on the console will automatically light in a pre-set sequence; the buttons on the console cannot be operated. **If a "d" appears in the display when the information mode is selected, press the Speed – button so the display is blank.**

To exit the information mode, remove the key.

THE OPTIONAL CHEST PULSE SENSOR

An optional chest pulse sensor adds even more features to the console. The chest pulse sensor provides hands-free operation and enables you to use the console's heart rate programs. **To purchase the chest pulse sensor, call the toll-free telephone number on the front cover of this manual.**

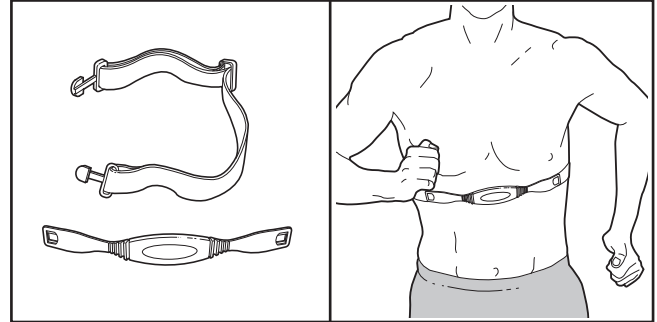

HOW TO FOLD AND MOVE THE INCLINE TRAINER

HOW TO FOLD THE INCLINE TRAINER FOR STORAGE

Before folding the Incline Trainer, adjust the incline to the lowest position. If this is not done, the Incline Trainer may be permanently damaged. Remove the key and unplug the power cord. **CAUTION: You must be able to safely lift 45 pounds (20 kg) to raise, lower, or move the Incline Trainer.**

1. Hold the Incline Trainer with your hands in the location shown by the arrow at the right. **CAUTION: To decrease the possibility of injury, bend your legs and keep your back straight. As you raise the Incline Trainer, make sure to lift with your legs rather than your back.** Raise the Incline Trainer about halfway to the vertical position.

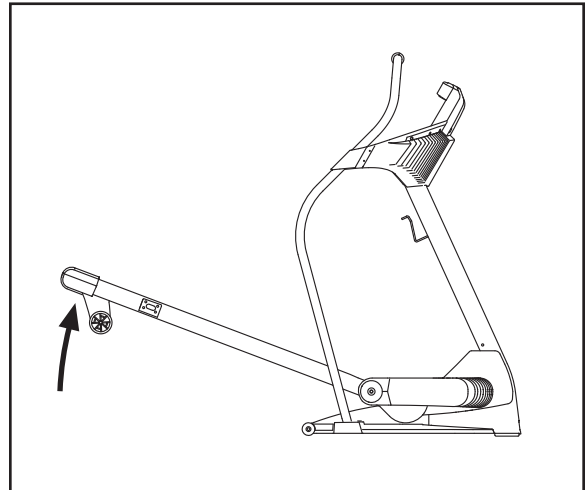

2. Move your right hand to the position shown and hold the Incline Trainer firmly. Using your left hand, pull the latch knob to the left and hold it. Raise the Incline Trainer until the latch pin is aligned with the indicated hole in the catch. Insert the latch pin into the hole. **Make sure that the latch pin is fully inserted into the hole.**

To protect the floor or carpet from damage, place a mat under the Incline Trainer. Keep the Incline Trainer out of direct sunlight. Do not leave the Incline Trainer in the storage position in temperatures above 85° Fahrenheit.

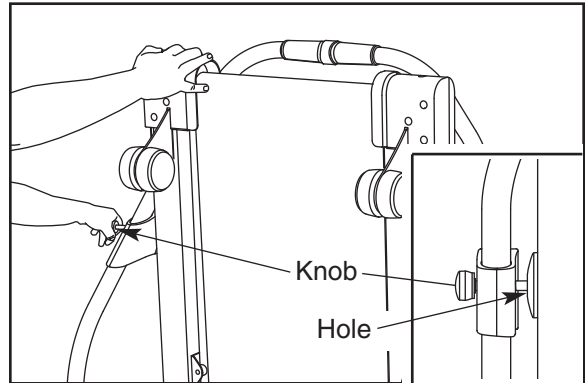

HOW TO MOVE THE INCLINE TRAINER

Before moving the Incline Trainer, convert the Incline Trainer to the storage position as described above. **Make sure that the latch pin is fully inserted into the hole in the side of the Incline Trainer.**

1. Hold the handrails as shown and place one foot against a wheel.
2. Tilt the Incline Trainer back until it rolls freely on the wheels. Carefully move the Incline Trainer to the desired location. **Never move the Incline Trainer without tipping it back. To reduce the risk of injury, use extreme caution while moving the Incline Trainer. Do not attempt to move the Incline Trainer over an uneven surface.**
3. Place one foot against a wheel, and carefully lower the Incline Trainer until it is resting in the storage position.

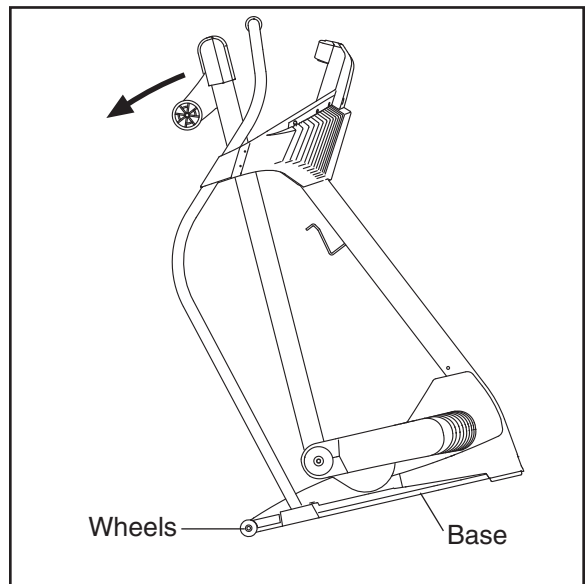

HOW TO LOWER THE INCLINE TRAINER FOR USE

1. Hold the upper end of the Incline Trainer with your right hand as shown. Using your left hand, pull the latch knob to the left and hold it. Pivot the Incline Trainer down until the frame is past the pin on the latch knob.

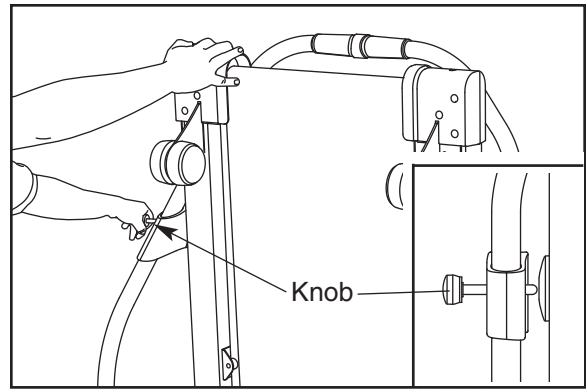

2. Hold the Incline Trainer firmly with both hands, and lower the Incline Trainer to the floor. **To decrease the possibility of injury, bend your legs and keep your back straight.**

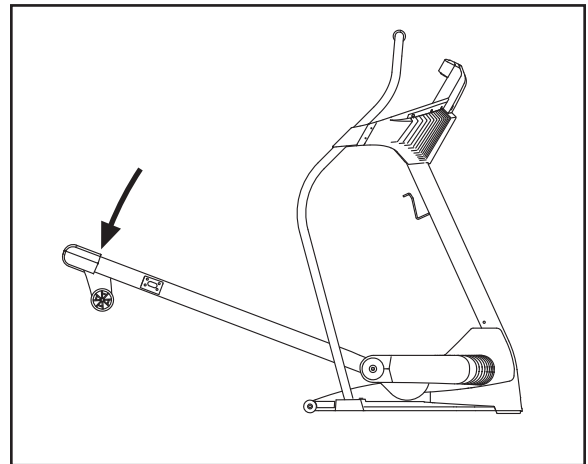

TROUBLESHOOTING

Most Incline Trainer problems can be solved by following the steps below. Find the symptom that applies, and follow the steps listed. If further assistance is needed, see the front cover of this manual.

PROBLEM: The power does not turn on

SOLUTION: a. Make sure that the power cord is plugged into a surge suppressor, and that the surge suppressor is plugged into a properly grounded outlet (see page 11). Use only a single-outlet surge suppressor that meets all of the specifications described on page 11. Important: The Incline Trainer is not compatible with GFCI-equipped outlets.

b. After the power cord has been plugged in, make sure that the key is fully inserted into the console.

c. Check the reset/off circuit breaker located on the Incline Trainer frame near the power cord. If the switch protrudes as shown, the circuit breaker has tripped. To reset the circuit breaker, wait for five minutes and then press the switch to the reset position.

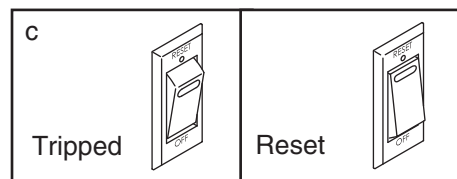

PROBLEM: The power turns off during use

SOLUTION: a. Check the reset/off circuit breaker (see the drawing above). If the circuit breaker has tripped, wait for five minutes and then press the switch to the reset position.

b. Make sure that the power cord is plugged in. If the power cord is plugged in, unplug it, wait for five minutes, and then plug it back in.

c. Remove the key from the console. Reinsert the key fully into the console.

d. If the Incline Trainer still will not run, see the front cover of this manual.

PROBLEM: The displays of the console do not function properly

SOLUTION: a. Adjust the incline high enough to remove the two Screws (3) and the two Belly Pan Screws (70) from the locations shown. **Do not remove the Screws until you have removed the key from the console and UNPLUGGED THE POWER CORD.** Remove the two Screws (3) and the two Belly Pan Screws (128).

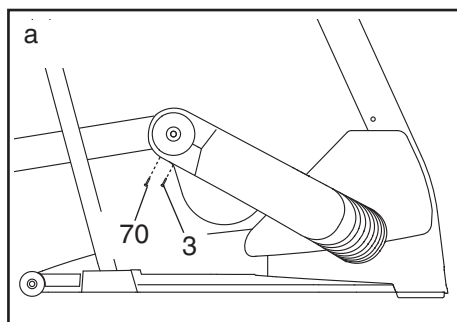

Remove the four Screws (3) from the Hood (37), and carefully remove the Hood.

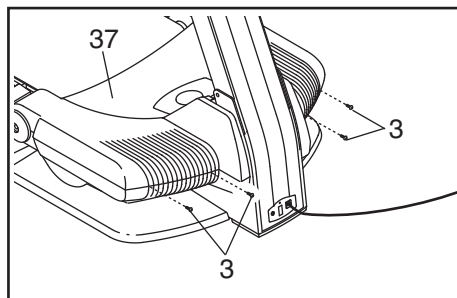

Locate the Reed Switch (20) and the Magnet (8) on the left side of the Pulley (7). Turn the Pulley until the Magnet is aligned with the Reed Switch. **Make sure that the gap between the Magnet and the Reed Switch is about 1/8"**. If necessary, loosen the Screw (21), move the Reed Switch slightly, and then retighten the Screw. Reattach the Hood (37), making sure that the Screws (3, 70) are inserted into the same holes from which they were removed. Run the Incline Trainer for a few minutes to check for a correct speed reading.

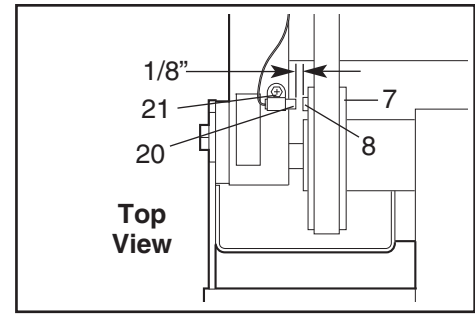

PROBLEM: The walking belt slows when walked on

SOLUTION: a. Use only a single-outlet surge suppressor that meets all of the specifications described on page 11.

b. If the walking belt is overtightened, Incline Trainer performance may decrease and the walking belt may become damaged. Remove the key and **UNPLUG THE POWER CORD**. Using the allen wrench, turn both rear roller adjustment bolts counterclockwise, 1/4 of a turn. When the walking belt is properly tightened, you should be able to lift each edge of the walking belt 3 to 4 inches off the walking platform. Be careful to keep the walking belt centered. Plug in the power cord, insert the key, and run the Incline Trainer for a few minutes. Repeat until the walking belt is properly tightened.

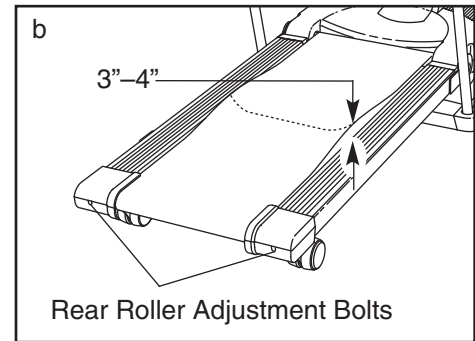

c. If the walking belt still slows when walked on, see the front cover of this manual.

PROBLEM: The walking belt is off-center or slips when walked on

SOLUTION: a. If the walking belt is off-center, remove the key and **UNPLUG THE POWER CORD**. **If the walking belt has shifted to the left**, use the allen wrench to turn the left rear roller bolt clockwise 1/2 of a turn; **if the walking belt has shifted to the right**, turn the left rear roller bolt counterclockwise 1/2 of a turn. Be careful not to overtighten the walking belt. Plug in the power cord, insert the key, and run the Incline Trainer for a few minutes. Repeat until the walking belt is centered.

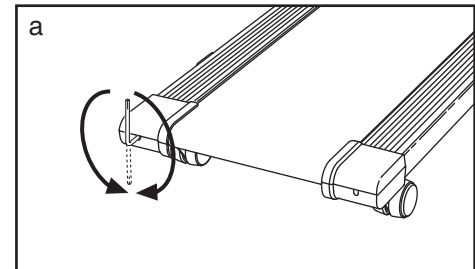

b. If the walking belt slips when walked on, first remove the key and **UNPLUG THE POWER CORD**. Using the allen wrench, turn both rear roller bolts clockwise, 1/4 of a turn. When the walking belt is correctly tightened, you should be able to lift each edge of the walking belt 3 to 4 inches off the walking platform. Be careful to keep the walking belt centered. Plug in the power cord, insert the key, and carefully walk on the Incline Trainer for a few minutes. Repeat until the walking belt is properly tightened.

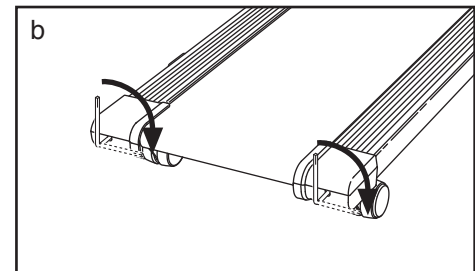

PROBLEM: The incline of the Incline Trainer does not change correctly or does not change when iFIT.com CDs and videocassettes are used

SOLUTION: a. With the key in the console, press one of the Incline buttons. **While the incline is changing, remove the key.** After a few seconds, reinsert the key. The Incline Trainer will automatically rise to the maximum incline level and then return to the minimum level. This will recalibrate the incline system.

CONDITIONING GUIDELINES

⚠️ WARNING: Before beginning this or any exercise program, consult your physician. This is especially important for individuals over the age of 35 or individuals with pre-existing health problems.

The pulse sensor is not a medical device. Various factors, including the user's movement, may affect the accuracy of heart rate readings. The pulse sensor is intended only as an exercise aid in determining heart rate trends in general.

The following guidelines will help you to plan your exercise program. For more detailed exercise information, obtain a reputable book or consult your physician.

EXERCISE INTENSITY

Whether your goal is to burn fat or to strengthen your cardiovascular system, the key to achieving the desired results is to exercise with the proper intensity. The proper intensity level can be found by using your heart rate as a guide. The chart below shows recommended heart rates for fat burning and aerobic exercise.

HEART RATE TRAINING ZONES							
AEROBIC	165	155	145	140	130	125	115
MAX FAT BURN	145	138	130	125	118	110	103
FAT BURN	125	120	115	110	105	95	90
Age	20	30	40	50	60	70	80

To find the proper heart rate for you, first find your age near the bottom of the chart (ages are rounded off to the nearest ten years). Next, find the three numbers above your age. The three numbers define your "training zone." The lower two numbers are recommended heart rates for fat burning; the higher number is the recommended heart rate for aerobic exercise.

Fat Burning

To burn fat effectively, you must exercise at a relatively low intensity level for a sustained period of time. During the first few minutes of exercise, your body uses easily accessible *carbohydrate calories* for energy. Only after the first few minutes does your body

begin to use stored *fat calories* for energy. If your goal is to burn fat, adjust the speed and incline of the Incline Trainer until your heart rate is near the lowest number in your training zone.

For maximum fat burning, adjust the speed and incline of the Incline Trainer until your heart rate is near the middle number in your training zone.

Aerobic Exercise

If your goal is to strengthen your cardiovascular system, your exercise must be "aerobic." Aerobic exercise is activity that requires large amounts of oxygen for prolonged periods of time. This increases the demand on the heart to pump blood to the muscles, and on the lungs to oxygenate the blood. For aerobic exercise, adjust the speed and incline of the Incline Trainer until your heart rate is near the highest number in your training zone.

WORKOUT GUIDELINES

Each workout should include the following three parts:

A Warm-up—Start each workout with 5 to 10 minutes of stretching and light exercise. A proper warm-up increases your body temperature, heart rate and circulation in preparation for exercise.

Training Zone Exercise—After warming up, increase the intensity of your exercise until your pulse is in your training zone for 20 to 60 minutes. (During the first few weeks of your exercise program, do not keep your pulse in your training zone for longer than 20 minutes.) Breathe regularly and deeply as you exercise—never hold your breath.

A Cool-down—Finish each workout with 5 to 10 minutes of stretching to cool down. This will increase the flexibility of your muscles and will help prevent post-exercise problems.

EXERCISE FREQUENCY

To maintain or improve your condition, complete three workouts each week, with at least one day of rest between workouts. After a few months, you may complete up to five workouts each week if desired. The key to success is to make exercise a regular and enjoyable part of your everyday life.

PART LIST—Model No. RBHK15305.0

R0705A

To locate the parts listed below, see the EXPLODED DRAWING attached in the center of this manual.

Key No.	Qty.	Description	Key No.	Qty.	Description
1	2	Foot Rail	52	2	Rear Wheel
2	1	Left Front Endcap	53	4	Rear Wheel Cover
3	23	Screw	54	4	Wheel Bolt
4	2	Frame Pivot Bolt	55	6	1" Bolt
5	2	Rear Roller Washer	56	1	Left Wheel Bracket
6	1	Motor Belt	57	1	Right Rear Endcap
7	1	Front Roller/Pulley	58	1	Rear Roller
8	1	Magnet	59	1	Right Wheel Bracket
9	2	Frame Pivot Nut	60	4	3/4" Bolt
10	2	Frame Spacer	61	1	Left Outer Cover
11	2	Idler Arm Washer	62	1	Latch Assembly
12	2	Frame Pivot Washer	63	1	Static Warning Decal
13	9	Nut	64	1	Pulse Assembly
14	1	Idler Arm Pulley	65	1	Right Inner Cover
15	1	Idler Pulley Bolt	66	5	3/4" Screw
16	1	Idler Arm Bolt	67	2	Lower Handrail
17	1	Idler Arm Bushing	68	1	Upper Handrail
18	1	Idler Arm	69	1	Console
19	1	Idler Arm Spring	70	6	Belly Pan Screw
20	1	Reed Switch	71	22	Screw
21	5	Small Screw	72	1	Access Door Screw
22	1	Sensor Clip	73	2	Upper Body Handle
23	1	Lift Frame	74	2	Rope Guide Bracket
24	1	Drive Motor	75	1	Top Housing
25	2	Motor Bolt	76	1	Walking Platform
26	2	Lift Frame Pivot Bolt	77	1	Controller Wire
27	2	Lift Frame Pivot Washer	78	6	Pulley
28	1	Controller	79	4	Pulley Nut
29	2	Controller Screw	80	2	Pulley Bolt
30	2	Warning Decal	81	6	Inside Cover Bolt
31	1	Ferrite Clamp	82	2	Fan
32	14	1/2" Screw	83	4	Fan Screw
33	1	Power Board	84	1	Key Clip
34	4	Plastic Stand-off	85	1	Power Cord Assembly
35	1	Electronics Bracket	86	1	Resistor
36	1	Hood Cover	87	2	Upright Pivot Bushing
37	1	Hood	88	1	Right Outer Cover
38	1	Belly Pan	89	1	Upright Pivot Shaft
39	2	Belt Guide	90	2	Upright Pivot Bolt
40	1	Right Front Endcap	91	1	Controller Plate
41	2	Front Walking Platform Screw	92	1	Tension Motor Wire
42	4	Walking Platform Screw	93	6	Base Pad
43	1	Frame	94	10	3/4" Tek Screw
44	4	Belt Guide Screw	95	1	Upright Base Belly Pan
45	4	Isolator	96	1	Upright Base
46	4	Isolator Bolt	97	2	Washer
47	1	Latch Catch	98	2	3" Bolt
48	18	Misc. Screw	99	2	Front Wheel
49	2	Endcap Plate	100	2	Incline Motor Bolt, Top
50	1	Left Rear Endcap	101	1	Incline Motor
51	2	Rear Roller Adj. Bolt	102	1	Incline Wire Harness

Key No.	Qty.	Description	Key No.	Qty.	Description
103	1	Upright Base Pad	126	1	iFIT Cable
104	2	Incline Motor Bolt, Bottom	127	1	iFIT Jack
105	1	Base Hood	128	1	Latch Warning Decal
106	1	Left Inner Cover	129	4	Belly Pan Clip
107	1	Bottle Holder	130	16	Upright Cover Clip
108	1	Upright Cover, Back	131	2	Long Endcap Screw
109	1	Pulley Shaft	132	1	Console Warning Decal
110	1	Upright	133	1	Temp Sensor
111	1	Bottle Holder Clamp	134	1	Sensor Fastener
112	1	Access Door	135	1	Resistor
113	1	Upper Body Mechanism	136	2	Resistor Star Washer
114	1	Resistance Motor	#	1	46" Wire Harness
115	1	Upright Cover, Front	#	1	45" Console Wire Harness
116	4	Small Star Washer	#	1	14" Red Wire, 2F
117	1	Small Nut	#	1	12" Red Wire, 2F
118	2	Upright Bolt	#	1	14" White Wire, 2F
119	4	Small Nut	#	1	8" Green Wire, F/Ring
120	8	Front Endcap Screw	#	1	4" Green Wire, F/Ring
121	1	Walking Belt	#	2	4" Blue Wire, M/F
122	1	Allen Wrench	#	1	User's Manual
123	9	Cable Tie			
124	1	Releasable Tie			
125	9	Tie Block			

#These parts are not illustrated
Specifications are subject to change without notice.

ORDERING REPLACEMENT PARTS

To order replacement parts, see the front cover of this manual. When ordering parts, please be prepared to give the following information:

- the MODEL NUMBER OF THE PRODUCT (RBHK15305.0)
- the NAME OF THE PRODUCT (REEBOK X5 Incline Trainer)
- the SERIAL NUMBER OF THE PRODUCT (see the front cover of this manual)
- the KEY NUMBER AND DESCRIPTION OF THE PART(S) (see the PART LIST on pages 34 and 35 and the EXPLODED DRAWING attached in the center of this manual)

EXPLODED DRAWING—Model No. RBHK15305.0

R0705A

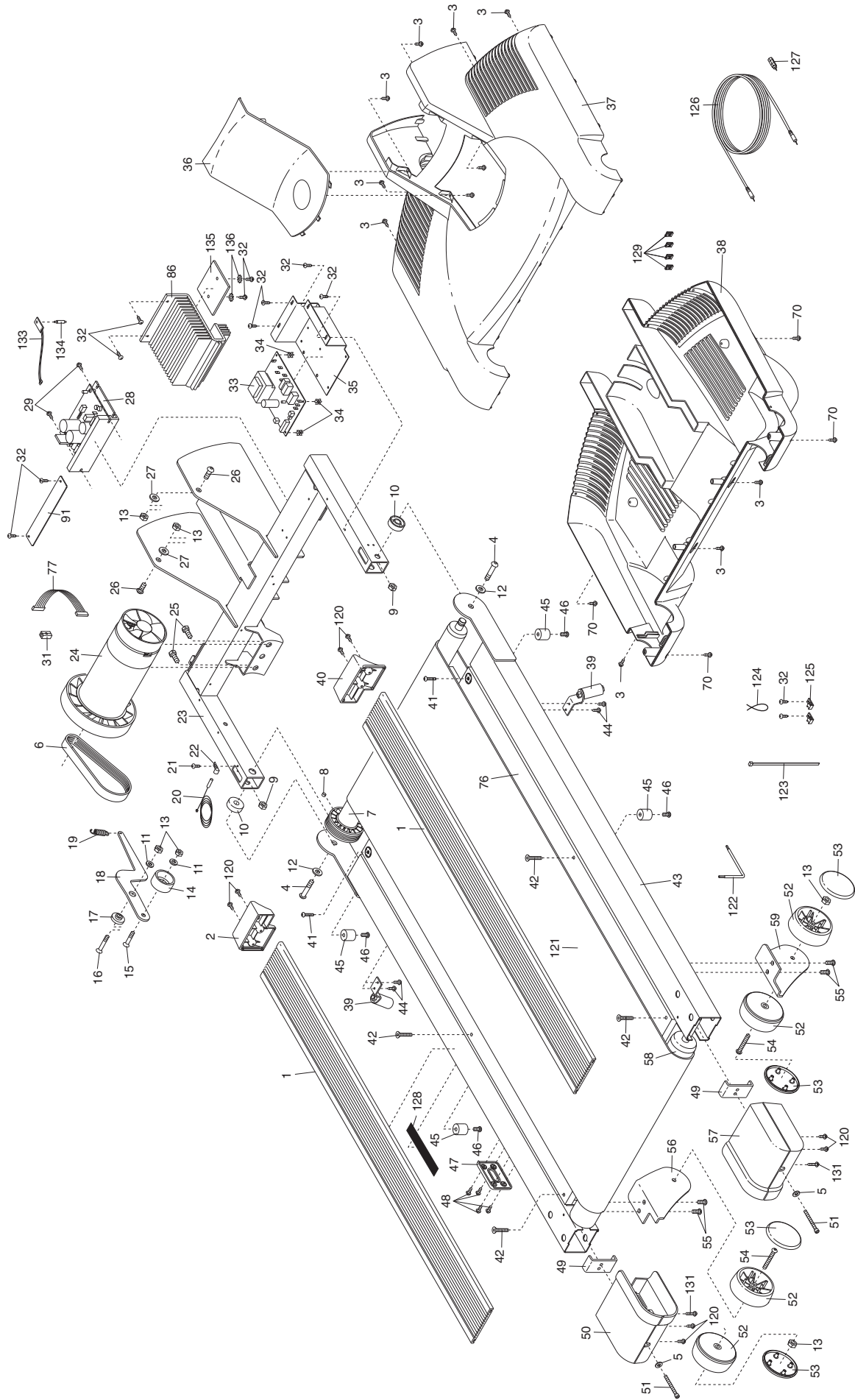

EXPLODED DRAWING—Model No. RBHK15305.0

R0705A

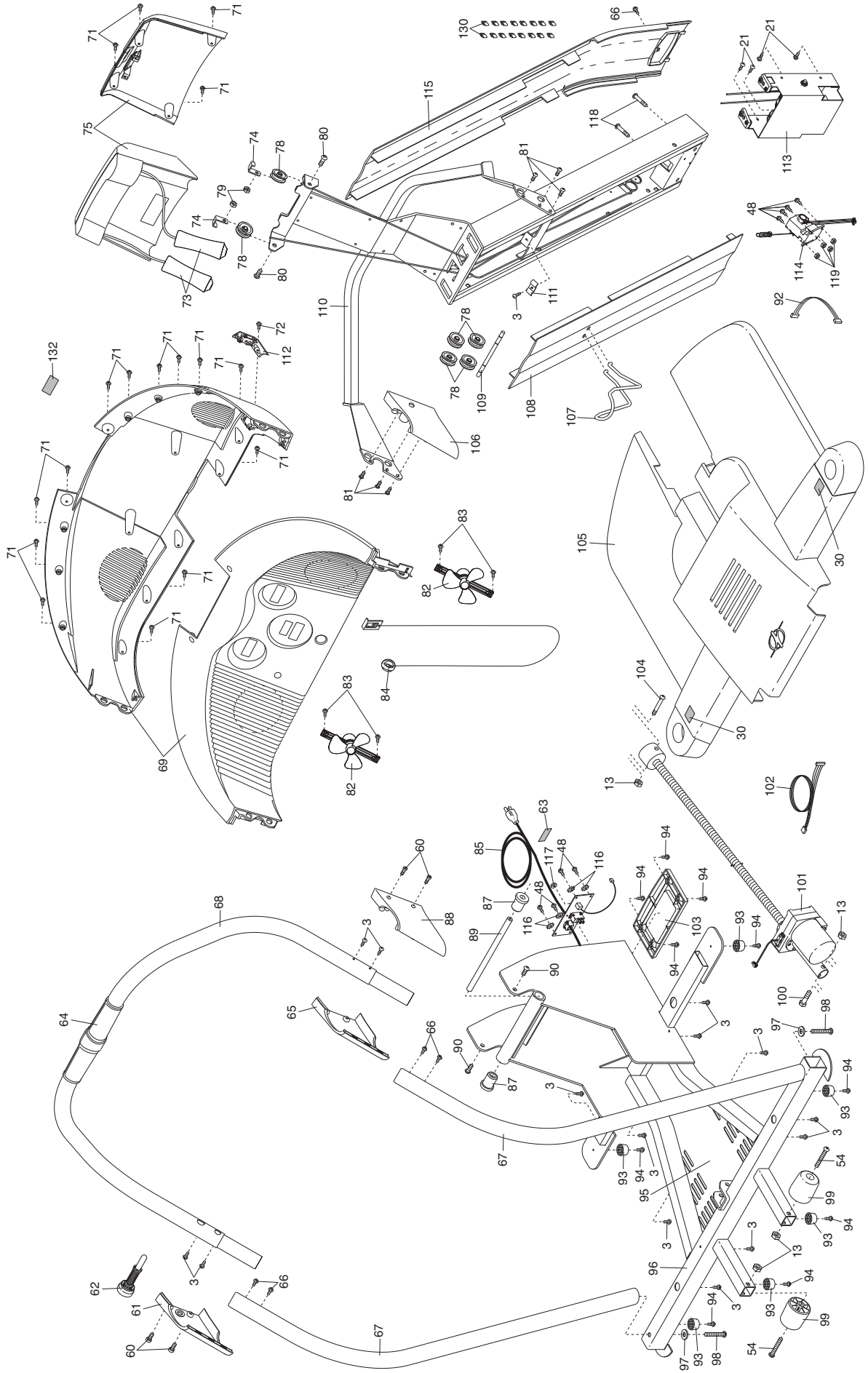

LIMITED WARRANTY

WHAT IS COVERED—The entire REEBOK INCLINE TRAINER X5 (“Product”) is warranted to be free of all defects in material and workmanship.

WHO IS COVERED—The original purchaser or any person receiving the Product as a gift from the original purchaser.

HOW LONG IS IT COVERED—ICON Health & Fitness, Inc. (“ICON”), warrants the drive motor for a lifetime. Parts and labor are covered for one year after the date of purchase.

WHAT WE DO TO CORRECT COVERED DEFECTS—We will ship to you, without charge, any replacement part or component, providing the repairs are authorized by ICON first and are performed by an ICON trained and authorized service provider, or, at our option, we will replace the Product.

WHAT IS NOT COVERED—Any failures or damage caused by unauthorized service, misuse, accident, negligence, improper assembly or installation, alterations, modifications without our written authorization or by failure on your part to use, operate, and maintain as set out in your User’s Manual (“Manual”).

WHAT YOU MUST DO—Always retain proof of purchase, such as your bill of sale; store, operate, and maintain the Product as specified in the Manual; notify our Customer Service Department of any defect within 10 days after discovery of the defect; as instructed, return any defected part for replacement or, if necessary, the entire product, for repair.

USER’S MANUAL—It is VERY IMPORTANT THAT YOU READ THE MANUAL before operating the Product. Remember to do the periodic maintenance requirements specified in the Manual to assure proper operation and your continued satisfaction.

HOW TO GET PARTS AND SERVICE—Simply call our Customer Service Department at 1-877-994-4999 and tell them your name and address and the serial number of your Product. They will tell you how to get a part replaced, or if necessary, arrange for service where your Product is located or advise you how to ship the Product for service. Before shipping, always obtain a Return Authorization Number (RA No.) from our Customer Service Department; securely pack your Product (save the original shipping carton if possible); put the RA No. on the outside of the carton and insure the product. Include a letter explaining the product or problem and a copy of your proof of purchase if you believe the service is covered by warranty.

ICON is not responsible or liable for indirect, special or consequential damages arising out of or in connection with the use or performance of the product or damages with respect to any economic loss, loss of property, loss of revenues or profits, loss of enjoyment or use, costs of removal, installation or other consequential damages of whatsoever nature. Some states do not allow the exclusion or limitation of incidental or consequential damages. Accordingly, the above limitation may not apply to you.

The warranty extended hereunder is in lieu of any and all other warranties and any implied warranties of merchantability or fitness for a particular purpose is limited in its scope and duration to the terms set forth herein. Some states do not allow limitations on how long an implied warranty lasts. Accordingly, the above limitation may not apply to you.

No one is authorized to change, modify or extend the terms of this limited warranty.

This warranty gives you specific legal rights and you may have other rights which vary from state to state.

ICON HEALTH & FITNESS, INC., 1500 S. 1000 W., LOGAN, UT 84321-9813