

Patent Pending

Model No. RBEX31080

Serial No. \_\_\_\_\_

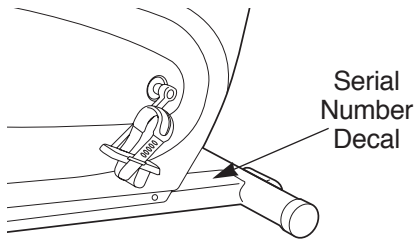

## QUESTIONS?

As a manufacturer, we are committed to providing complete customer satisfaction. If you have questions, or if there are missing or damaged parts, we will guarantee complete satisfaction through direct assistance from our factory.

**TO AVOID UNNECESSARY DELAYS, PLEASE CALL DIRECT TO OUR TOLL-FREE CUSTOMER HOT LINE.** The trained technicians on our customer hot line will provide immediate assistance, free of charge to you.

**CUSTOMER HOT LINE:**

**1-800-999-3756**

Mon.–Fri., 6 a.m.–6 p.m. MST

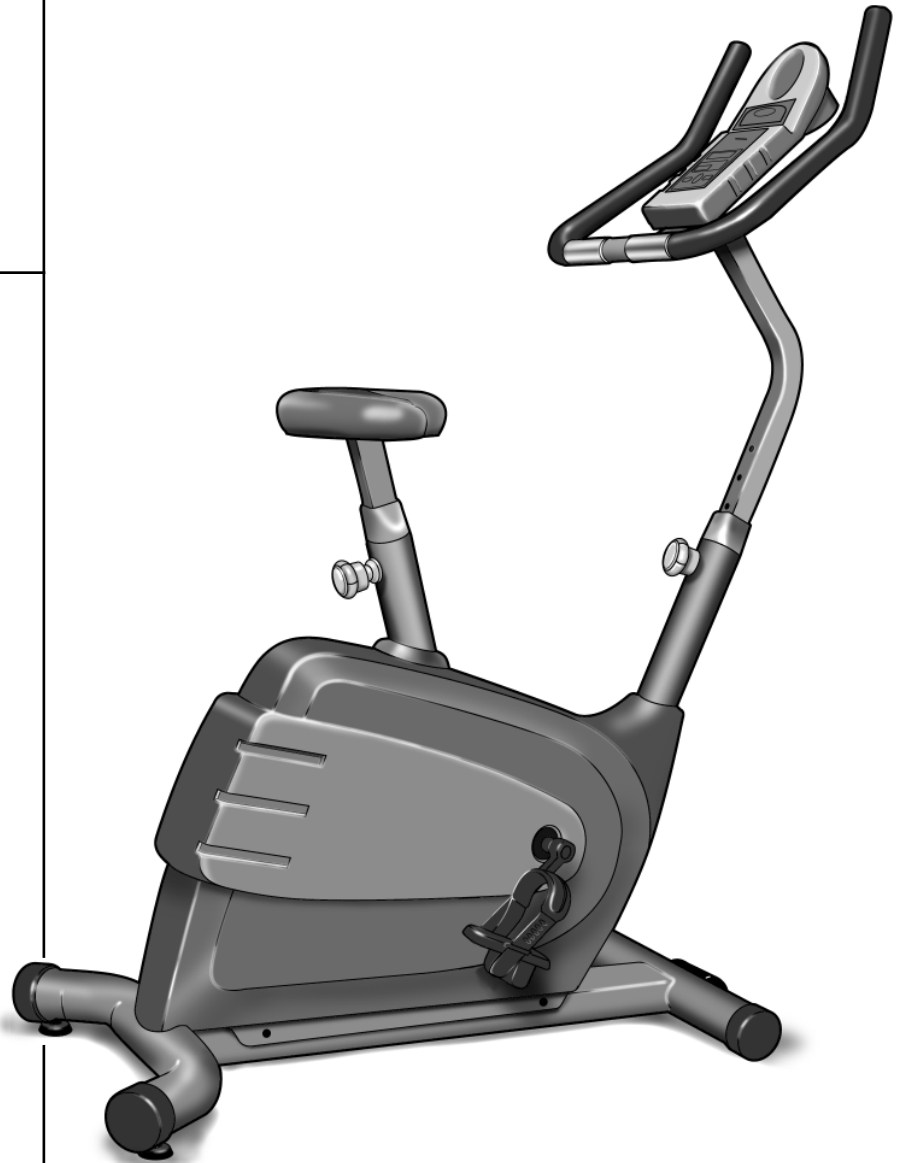

## CAUTION

Read all precautions and instructions in this manual before using this equipment. Keep this manual for future reference.

# USER'S MANUAL

# TABLE OF CONTENTS

IMPORTANT PRECAUTIONS	2
BEFORE YOU BEGIN	3
ASSEMBLY	4
HOW TO OPERATE THE EXERCISE CYCLE	8
HOW TO USE THE PULSE SENSOR	11
MAINTENANCE AND STORAGE	12
CONDITIONING GUIDELINES	13
PART LIST	14
EXPLODED DRAWING	15
ORDERING REPLACEMENT PARTS	.Back Cover
LIMITED WARRANTY	.Back Cover

## IMPORTANT PRECAUTIONS

**WARNING:** To reduce the risk of serious injury, read the following important precautions before using the REEBOK® CYC4 exercise cycle.

1. Read all instructions in this manual before using the CYC4.
2. Use the CYC4 only as described in this manual.
3. It is the responsibility of the owner to ensure that all users of the CYC4 are adequately informed of all precautions.
4. The CYC4 is intended for in-home use only. Do not use the CYC4 in a commercial, rental, or institutional setting.
5. Use the CYC4 indoors on a level surface. Keep the CYC4 away from moisture and dust. Place a mat under the CYC4 to protect the floor or carpet.
6. Inspect and tighten all parts regularly. Replace any worn parts immediately.
7. Keep children under the age of 12 and pets away from the CYC4 at all times.
8. The CYC4 should not be used by persons weighing more than 250 pounds.
9. Always keep your back straight when using the CYC4. Do not arch your back.
10. Wear appropriate clothing when exercising; do not wear loose clothing that could become caught on the CYC4. Always wear athletic shoes when using the CYC4.
11. The pulse sensor is not a medical device. Various factors, including the user's movement, may affect the accuracy of heart rate readings. The pulse sensor is intended only as an exercise aid in determining heart rate trends in general.
12. If you feel pain or dizziness while exercising, stop immediately and cool down.
13. The warnings shown below are found on the console of the CYC4. Make sure to familiarize yourself with the warnings before you use the CYC4.

**⚠ WARNING:** • Misuse of this equipment may result in serious injury.  
• Read user's manual and follow all warnings and operating instructions.  
• Never allow children to play on or around this equipment.

**WARNING:** Before beginning this or any exercise program, consult your physician. This is especially important for persons over the age of 35 or persons with pre-existing health problems. Read all instructions before using. ICON assumes no responsibility for personal injury or property damage sustained by or through the use of this product.

# BEFORE YOU BEGIN

Congratulations for selecting the new REEBOK® CYC4 exercise cycle. Cycling is one of the most effective exercises for increasing cardiovascular fitness, building endurance and toning the entire body. The REEBOK® CYC4 offers an impressive array of features designed to let you enjoy this healthful exercise in the comfort and privacy of your home.

**For your benefit, read this manual carefully before you use the REEBOK® CYC4.** If you have additional questions, please call our Customer Service

Department toll-free at 1-800-999-3756, Monday through Friday, 6 a.m. until 6 p.m. Mountain Time (excluding holidays). To help us assist you, please mention the product model number and serial number when calling. The model number is RBEX31080. The serial number can be found on a decal attached to the REEBOK® CYC4 (see the front cover of this manual).

Before reading further, please familiarize yourself with the parts that are labeled in the drawing below.

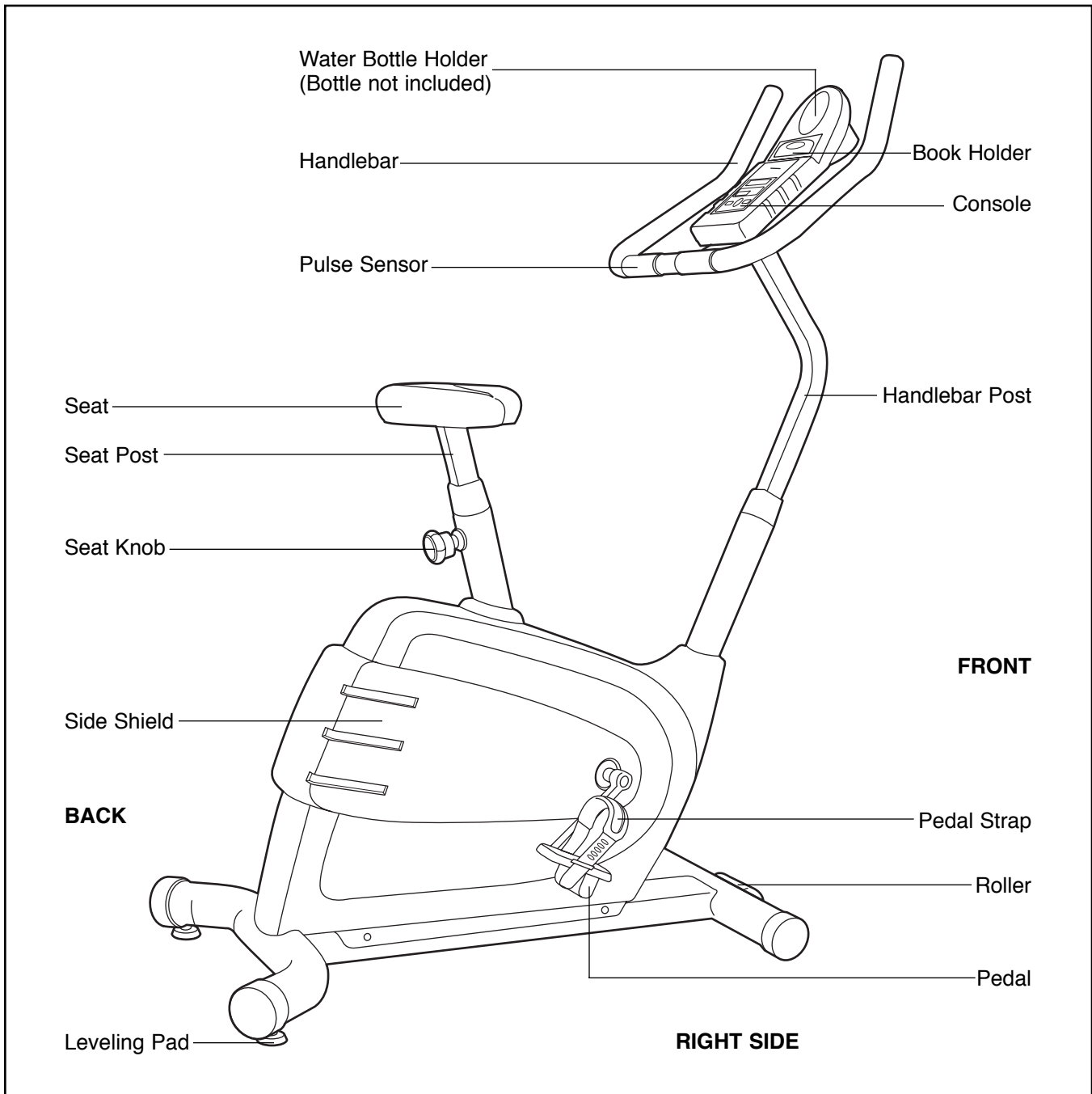

# ASSEMBLY

Place all parts of the exercise cycle in a cleared area and remove the packing materials. **Do not dispose of the packing materials until assembly is completed.**

**Assembly requires the included tools and your own adjustable wrench**  .

## PART CHART

Use the part drawings below to identify the small parts used in assembly. The number in parenthesis below each drawing refers to the key number of the part, from the PART LIST on page 14. The second number refers to the quantity used in assembly. **Note: Some small parts may have been pre-attached for shipping. If a part is not in the parts bag, check to see if it has been pre-assembled.**

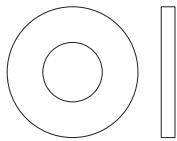

M8 Flat Washer (18)–7

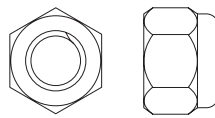

M8 Black Nylon Locknut (56)–4



M4 x 10mm Screw (21)–4

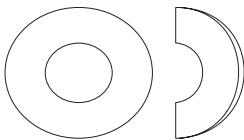

M8 Curved Washer (28)–8

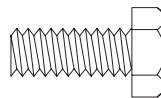

M6 x 16mm Hex Screw (29)–4

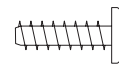

M6 x 10mm Screw (26)–2

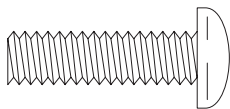

M8 x 25mm Button Screw (27)–4

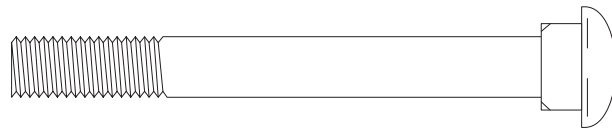

M8 x 70mm Carriage Bolt (72)–2

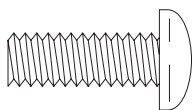

M8 x 20mm Button Screw (19)–3

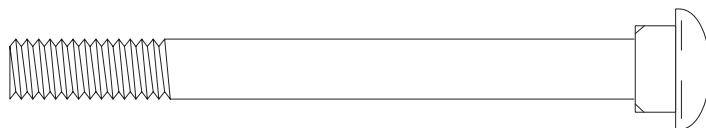

M8 x 80mm Carriage Bolt (63)–2

1. Attach the Front Stabilizer (2) to the Frame (1) with two M8 x 70mm Carriage Bolts (72), two M8 Curved Washers (28), and two M8 Black Nylon Locknuts (56). **Make sure that the Front Stabilizer is turned so the Roller (75) is not touching the floor.**

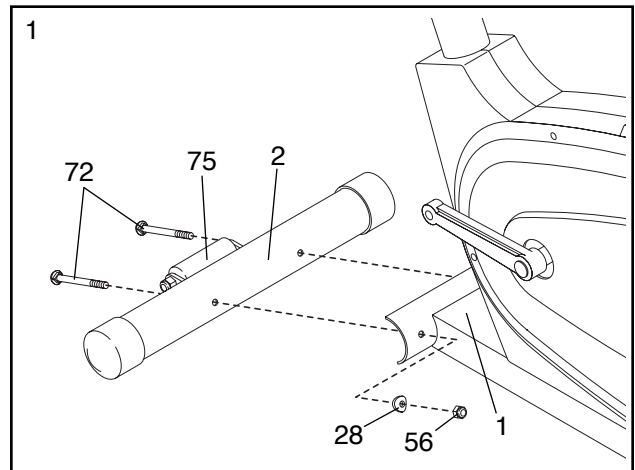

2. Attach the Rear Stabilizer (3) to the Frame (1) with two M8 x 80mm Carriage Bolts (63), two M8 Curved Washers (28), and two M8 Black Nylon Locknuts (56).

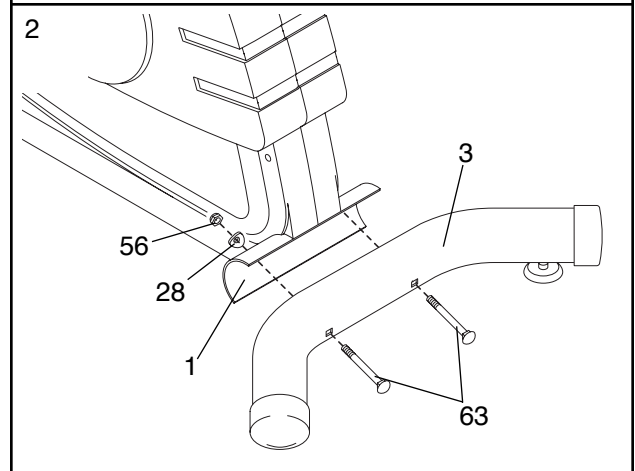

3. While another person holds the Handlebar Post (6) near the Frame (1) as shown, connect the Upper Wire Harness (16) to the Lower Wire Harness (24). Next, insert the Handlebar Post into the Frame. **Be careful not to pinch the Wire Harnesses.**

Slide the Round Collar (13) down the Handlebar Post (6) and press it into the Frame (1). Secure the Round Collar with a M6 x 10mm Screw (26).

**Note: There are two sets of holes in the Handlebar Post (6) so you can attach the Handlebar Post at either of two height settings. Choose the setting that you think will be the most comfortable.** Secure the Handlebar Post to the Frame (1) with four M8 x 25mm Button Screws (27) and four M8 Curved Washers (28).

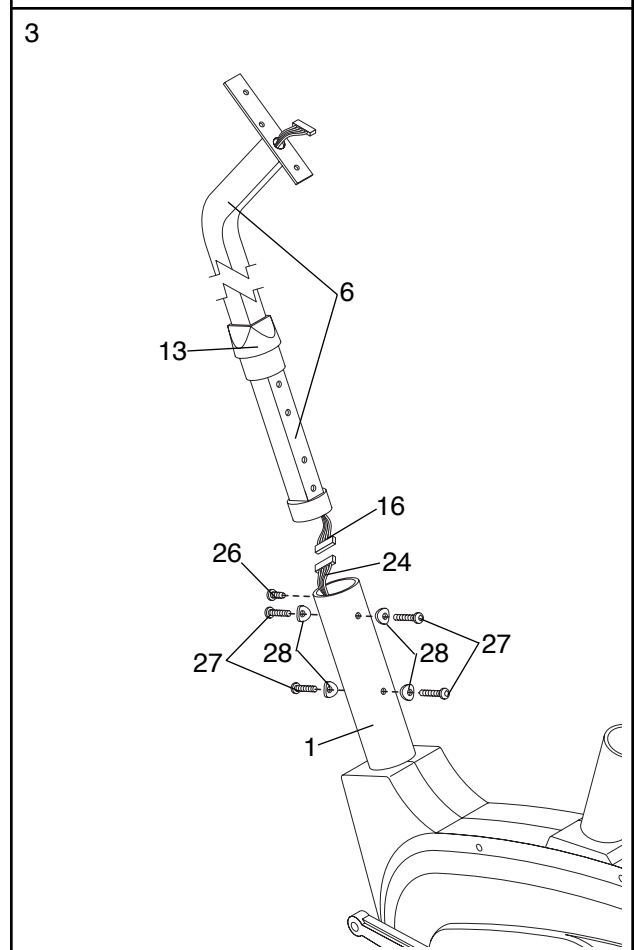

- Attach the Handlebar (7) to the Handlebar Post (6) with three M8 x 20mm Button Screws (19) and three M8 Flat Washers (18). **Make sure to thread the Upper Wire Harness (16) and the Pulse Wires (22) through the indicated hole in the Handlebar.**

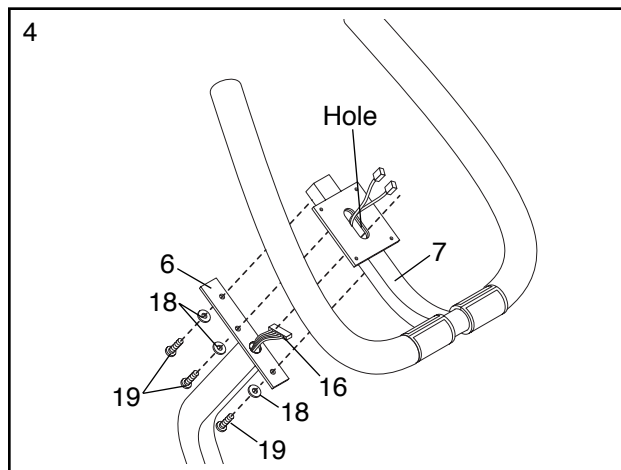

- The Console (9) requires two "AA" batteries (not included); alkaline batteries are recommended. Remove the battery cover from the back of the Console. Press two batteries into the battery clip as shown in the inset drawing. **Make sure that the negative (-) ends of the batteries are touching the springs.** Reattach the battery cover.

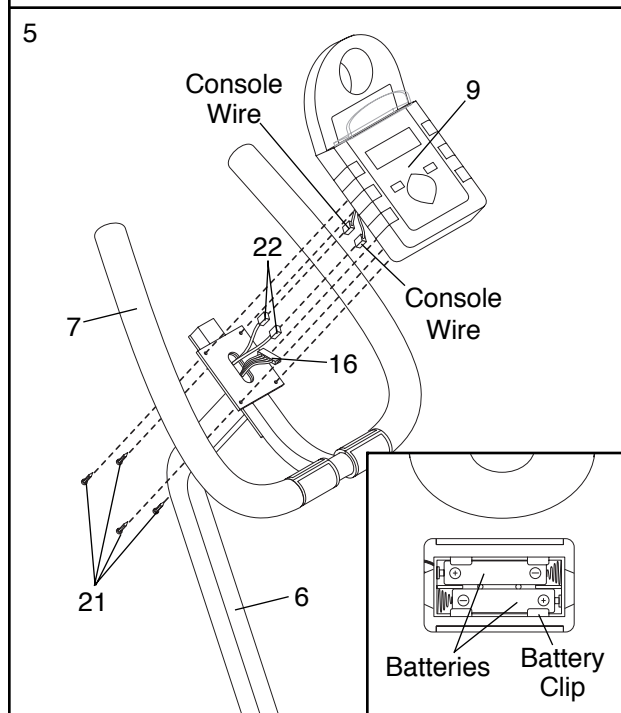

While another person holds the Console (9) near the Handlebar (7), connect the Pulse Wires (22) to the console wires. Next, plug the Upper Console Wire (16) into the socket in the back of the Console.

**Insert all excess wiring down into the Handlebar Post (6).** Attach the Console (9) to the Handlebar (7) with four M4 x 10mm Screws (21).

- Attach the Seat (12) to the Seat Post (11) with four M6 x 16mm Hex Screws (29) and four M8 Flat Washers (18). **Note: The Hex Screws and Flat Washers may be pre-attached to the Seat.**

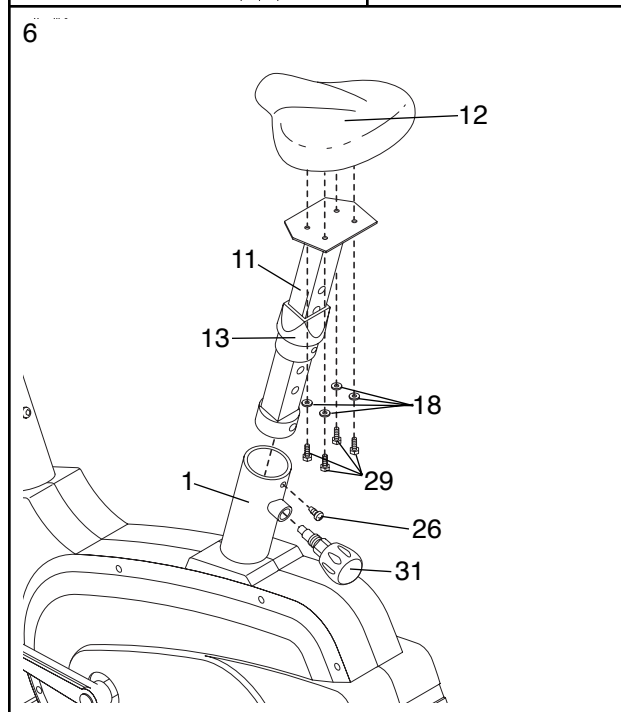

Using an adjustable wrench, remove the Seat Knob Assembly (31) from the Frame (1).

Insert the Seat Post (11) into the Frame (1). Slide the Round Collar (13) down the Seat Post and press it into the Frame. Secure the Round Collar to the Frame with a M6 x 10mm Screw (26).

Reinstall the Seat Knob Assembly (31) to the Frame (1).

7. Identify the Left Pedal (40). The Pedals are marked with an "L" for "left" or an "R" for "right" on the ends of the threaded shafts. Using an adjustable wrench, tighten the Left Pedal counterclockwise into the left Crank Arm (34).

Tighten the Right Pedal (not shown) clockwise into the right Crank Arm (34).

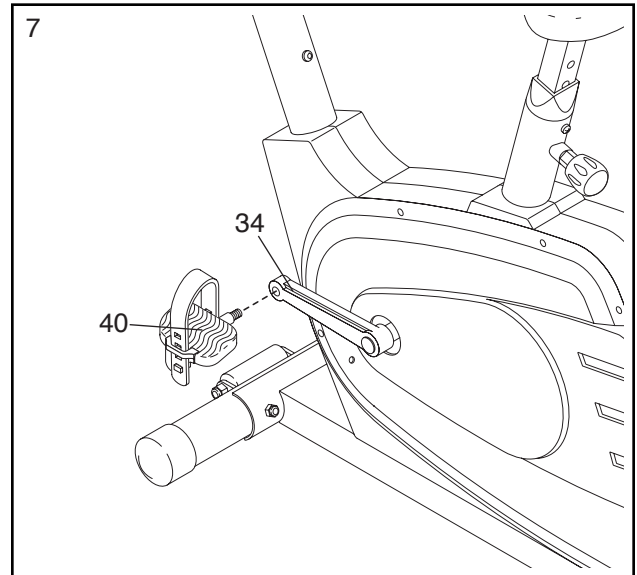

8. **Make sure that all parts are properly tightened before you use the exercise cycle.**

# HOW TO OPERATE THE EXERCISE CYCLE

## HOW TO ADJUST THE HEIGHT OF THE SEAT

For effective exercise, the seat should be at the proper height. As you pedal, there should be a slight bend in your knees when the pedals are in the lowest position.

To adjust the seat, first turn the seat knob counterclockwise several turns to loosen it. Next, pull back the knob, slide the seat post up or down as desired, and then release the knob.

**Move the seat post up or down slightly to make sure that it locks into place.** Finally, turn the knob clockwise to retighten it.

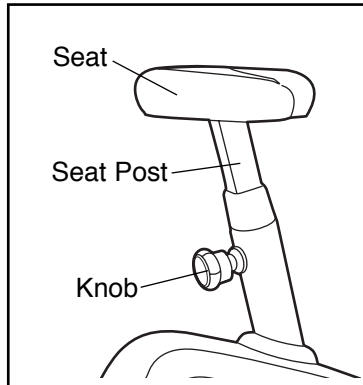

## HOW TO ADJUST THE HANDLEBARS

The handlebars can be adjusted to either of two height settings. If you want to adjust the height, see assembly step 3 on page 5.

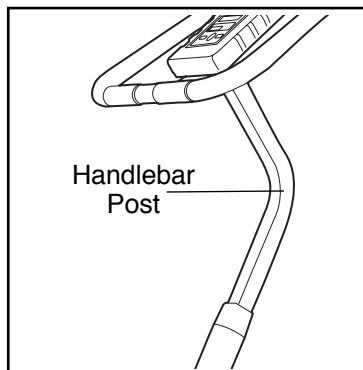

## HOW TO ADJUST THE PEDAL STRAPS

To adjust the pedal straps, first pull the ends of the straps off the tabs on the pedals. Press the straps back onto the tabs using different holes in the straps.

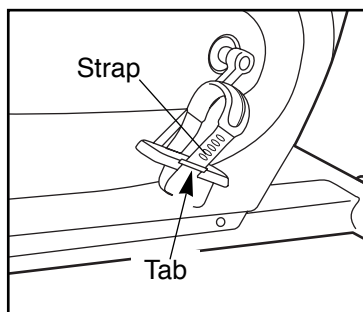

## DESCRIPTION OF THE CONSOLE

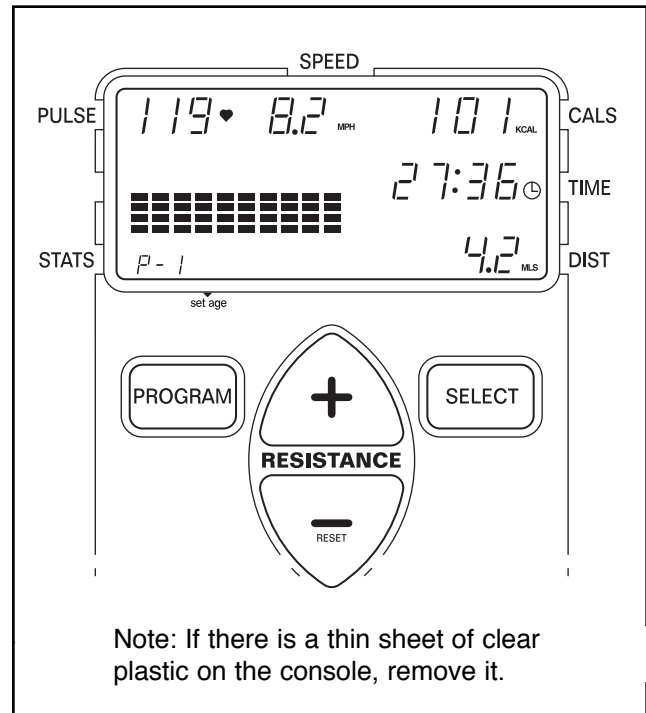

The innovative console offers an impressive array of features to help you get the most from your workouts. When the manual program is selected, you can adjust the pedaling resistance with a touch of a button. As you exercise, the console will display your pedaling speed, the number of Calories you have burned, the elapsed time and the distance you have pedaled. You can even measure your heart rate using the built-in pulse sensor.

The console also offers ten preset workout programs. Five programs automatically change the pedaling resistance as they guide you through effective workouts, and five programs automatically adjust the pedaling resistance to keep your heart rate near a preselected level during your workouts.

**Note:** Before the console can be operated, two "AA" batteries must be installed. See assembly step 5 on page 6 for installation instructions.



## HOW TO USE THE MANUAL PROGRAM

### 1 Turn on the power

To turn on the power, press any button on the console or simply begin pedaling. Note: If batteries were just installed, the power will already be on.

### 2 Select the manual program

Each time the power is turned on, the manual program will automatically be selected, as shown by the “P-1” in the display. (P-1 is the manual program.) If you have selected a different program, select the manual mode again by pressing the program button repeatedly until the “P-1” reappears.

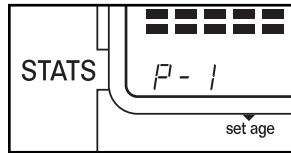

### 3 Begin pedaling and adjust the resistance of the pedals as desired

As you exercise, press the resistance + and – buttons to adjust the resistance of the pedals. Note: After the buttons are pressed, it may take a moment for the selected resistance setting to be reached.

### 4 Follow your progress with the console display

As you exercise, the matrix on the left side of the display will show your progress. During the first minute that you pedal, the first column of the matrix will flash; during the second minute, the second column will flash; during the third minute, the third column will flash, and so on, until the tenth column is flashing. After you have pedaled for ten minutes, the matrix will reset and the first column will begin to flash again.

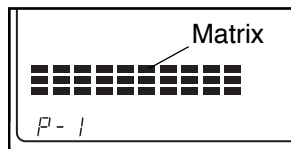

The matrix will also show the resistance level of the pedals. As you press the resistance + or – button, the height of the columns in the matrix will increase or decrease.

In addition to the matrix, the display will show your pedaling speed, the number of Calories you have burned, the elapsed time and the distance you have pedaled. The display will also show your heart rate when the pulse sensor is used (see step 5).

Note: The console can display speed in miles per hour, kilometers per hour or repetitions per minute.

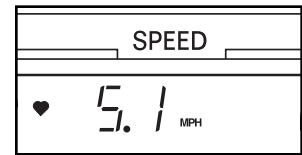

The letters “MPH,” “KMH,” or “RPM” will appear in the display to show which unit of measurement is selected. To change the unit of measurement, first hold down the select button for three seconds. Press the resistance + or – button to change the unit of measurement. Note: If you select miles per hour, distance will be displayed in miles. If you select kilometers per hour or repetitions per minute, distance will be displayed in kilometers.

### 5 Measure your heart rate if desired

To use the pulse sensor, place your hands on the metal contacts. Your palms must be resting on the contacts closest to you and your fingers must be touching the other contacts. Avoid moving your hands. After a moment, the heart indicator in the display will begin to flash and your heart rate will be shown. For the most

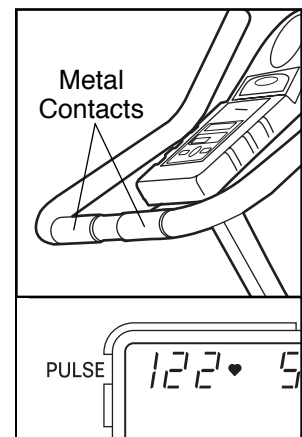

accurate heart rate reading, continue to hold the contacts for about 15 seconds. **WARNING: The pulse sensor is not a medical device. Various factors, including the user's movement, may affect the accuracy of heart rate readings. The pulse sensor is intended only as an exercise aid in determining heart rate trends in general.**

**Note: If your heart rate is not shown, press the resistance – button to reset the pulse sensor.** In addition, make sure that your hands are positioned as described above. Be careful not to move your hands excessively or squeeze the metal contacts too tightly.

### 6 When you are finished exercising, turn off the power

**To turn off the power, simply wait for about three minutes.** If the pedals are not moved and the console buttons are not pressed for three minutes, the power will turn off automatically.

## HOW TO USE A RESISTANCE PROGRAM

### 1 Turn on the power

To turn on the power, press any button on the console or simply begin pedaling. Note: If batteries were just installed, the power will already be on.

### 2 Select one of the resistance programs

Each time the power is turned on, the manual program will be selected, as shown by the “P-1” in the display. To select one of the resistance programs, press the program button repeatedly until a “P-2,” “P-3,” “P-4,” “P-5” or “P-6” appears in the display.

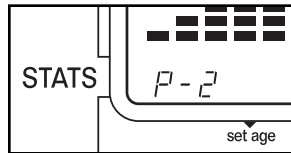

As you select each resistance program, the matrix will show the resistance settings of the program you have selected.

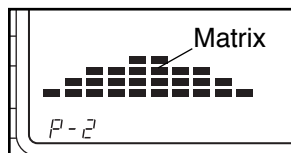

If you select program 2, for example, the matrix will show that the resistance will gradually increase during the first half of the program and then gradually decrease during the last half of the program.

### 3 Begin pedaling and follow your progress with the console display

As you exercise, follow your progress with the matrix on the left side of the display. During the first minute of the program, the first column of the matrix will flash; during the second minute, the second column will flash; during the third minute, the third column will flash. In addition, the resistance of the pedals will automatically change according to the height of the flashing column—the higher the column is, the greater the resistance will be. After ten minutes, the program will be completed.

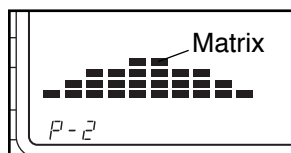

Note: If the program is too easy or too difficult, press the resistance + or – button to adjust the intensity level of the program. As you press the resistance + or – button, the height of the columns in the matrix will increase or decrease.

In addition to the matrix, the display will show your pedaling speed, the number of Calories you have burned, the elapsed time and the distance

you have pedaled. The display will also show your heart rate when the pulse sensor is used (see step 4).

### 4 Measure your heart rate if desired

Refer to step 5 on page 9. **Note: If your heart rate is not shown, press the resistance – button to reset the pulse sensor.**

### 5 When you are finished exercising, turn off the power

To turn off the power, simply wait for about three minutes. If the pedals are not moved and the console buttons are not pressed for three minutes, the power will turn off automatically.

## HOW TO USE A HEART RATE PROGRAM

### 1 Turn on the power

To turn on the power, press any button on the console or simply begin pedaling. Note: If batteries were just installed, the power will already be on.

### 2 Enter your age into the console

Before you use a heart rate program, you must enter your age into the console. To enter your age, first press the select button repeatedly until the letters “AGE” and a two-digit number appear at the bottom of the display. Next, press the resistance + or – button repeatedly to enter your age. After you have entered your age, the display will change back to the main display in six seconds.

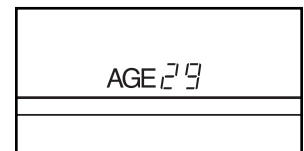

### 3 Select one of the heart rate programs

Each time the power is turned on, the manual program will be selected, as shown by the “P-1” in the display. To select one of the heart rate programs, press the program button repeatedly until a “P-7,” “P-8,” “P-9,” “P10” or “P11” appears in the display.

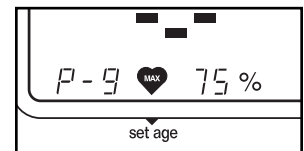

Each heart rate program is designed to keep your heart rate near a preselected percentage of your maximum heart rate while you exercise. (Your

maximum heart rate is estimated by subtracting your age from 220. For example, if you are 30 years old, your maximum heart rate is 190.)

Program 7 (P-7) will keep your heart rate near 50% of your maximum heart rate while you exercise; P-8 will keep your heart rate near 60% of your maximum heart rate; P-9 will keep your heart rate near 75% of your maximum heart rate; P10 will keep your heart rate near 85% of your maximum heart rate; and P11 will keep your heart rate near 95% of your maximum heart rate.

#### 4 Place your hands on the pulse sensor

See step 5 on page 9. **Note: If your heart rate is not shown, press the resistance – button to reset the pulse sensor.**

#### 5 Begin pedaling and follow your progress with the console display

As you exercise, follow your progress with the matrix on the left side of the display. During the first ten seconds of

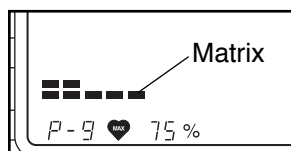

the program, the first column of the matrix will flash. After ten seconds, the column will move to the right and the first column will continue to flash. At the end of every ten seconds, all columns will move to the right. In addition, the resistance of the pedals will automatically increase or decrease, if necessary, to keep your heart rate near the preselected level. As the resistance changes, the height of the flashing column will also change. After ten minutes, the program will be completed. **Important: For the heart rate program to function properly, you must keep your hands on the pulse sensor. If your heart rate is not displayed, see PULSE SENSOR TROUBLE-SHOOTING on page 12.**

Note: When a heart rate program is used, the resistance buttons will not function.

In addition to the matrix, the display will show your heart rate, your pedaling speed, the number of Calories you have burned, the elapsed time and the distance you have pedaled.

#### 6 When you are finished exercising, turn off the power

To turn off the power, simply wait for about three minutes. If the pedals are not moved and the console buttons are not pressed for three minutes, the power will turn off automatically.

### HOW TO SET A WORKOUT GOAL

If desired, you can set a workout goal before you begin exercising. If you set a time, distance, or calorie goal, the console will count down the goal as you exercise and sound a tone when the goal is reached. If you set a maximum or minimum heart rate goal, the console will sound a tone to alert you if your heart rate is too high or too low during your workout.

Follow the instructions below to set a goal. **Note: Do not set more than one type of goal at a time.**

**Time goal**—Press the select button to select the time mode. Next, press the resistance buttons to set a time goal. Each button press will change the goal by 1 minute. After you have set a goal, the display will change back to the main display in six seconds.



**Distance goal**—Press the select button repeatedly to select the distance mode. Next, press the resistance buttons to set a distance goal. Each button press will change the goal by 0.5 miles or kilometers.

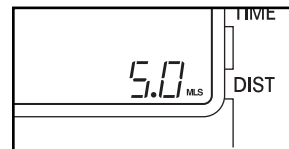

**Calorie goal**—Press the select button repeatedly to select the calorie mode. Next, press the resistance buttons to set a calorie goal. Each button press will change the goal by 10 calories.

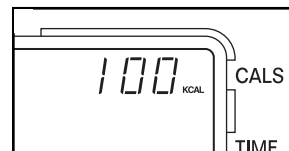

**Heart rate goal**—Press the select button repeatedly to select the maximum or minimum heart rate mode. Next, press the resistance buttons to set a heart rate goal. Each button press will change the heart rate goal by 5 beats per minute.

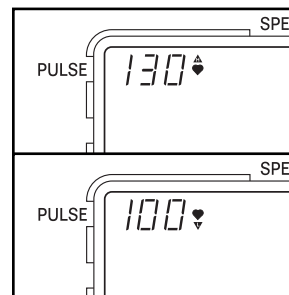

**Note: To cancel a goal, press the resistance – button for three seconds. Any time that the button is pressed for three seconds, the display will be reset.**

# MAINTENANCE AND TROUBLE-SHOOTING

Inspect and tighten all parts of the exercise cycle regularly. The exercise cycle can be cleaned with a soft, damp cloth. To prevent damage to the console, keep liquids away from the console and keep the console out of direct sunlight.

## BATTERY REPLACEMENT

If the console does not function properly, the batteries should be replaced. To replace the batteries, refer to assembly step 5 on page 6.

## HOW TO LEVEL THE EXERCISE CYCLE

If the exercise cycle does not sit flat on the floor, turn one or both of the leveling pads until the exercise cycle is level.

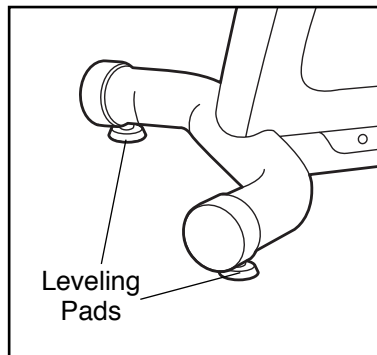

## PULSE SENSOR TROUBLE-SHOOTING

- Avoid moving your hands while using the pulse sensor. Excessive movement may interfere with heart rate readings.
- If your heart rate is not shown when the pulse sensor is used, press the resistance – button to reset the pulse sensor.
- Do not hold the metal contacts too tightly; doing so may interfere with heart rate readings.
- For the most accurate heart rate reading, hold the metal contacts for about 15 seconds.
- For optimal performance of the pulse sensor, keep the metal contacts clean. The contacts can be cleaned with a soft cloth—never use alcohol, abrasives, or chemicals.

# EXERCISE GUIDELINES

**WARNING:** Before beginning this or any exercise program, consult your physician. This is especially important for individuals over the age of 35 or individuals with pre-existing health problems.

**WARNING:** The pulse sensor is not a medical device. Various factors may affect the accuracy of heart rate readings. The pulse sensor is intended only as an exercise aid in determining heart rate trends in general.

Exercise has proven essential for good health and well-being. Regular participation in a well-rounded exercise program results in a stronger and more efficient heart, improved respiratory function, increased stamina, better weight management, increased ability to deal with stress, and greater self-esteem.

## EXERCISE INTENSITY

To maximize the benefits of exercising, it is important to exercise with the proper intensity. The proper intensity level can be found by using your heart rate as a guide. For effective aerobic exercise, your heart rate should be maintained at a level between 70% and 85% of your maximum heart rate as you exercise. This is known as your training zone. You can find your training zone in the table below. Training zones are listed according to age and physical condition.

AGE	TRAINING ZONE (BEATS/MIN.)	
	UNCONDITIONED	CONDITIONED
20	138–167	133–162
25	136–166	132–160
30	135–164	130–158
35	134–162	129–156
40	132–161	127–155
45	131–159	125–153
50	129–156	124–150
55	127–155	122–149
60	126–153	121–147
65	125–151	119–145
70	123–150	118–144
75	122–147	117–142
80	120–146	115–140

During the first few months of your exercise program, keep your heart rate near the low end of your training zone as you exercise. After a few months of regular exercise, your heart rate can be increased until it is near the middle of your training zone as you exercise.

To measure your heart rate, use the built-in pulse sensor. You can also measure your pulse by placing two fingers on your wrist as shown. Stop exercising and take a six-second heartbeat count.

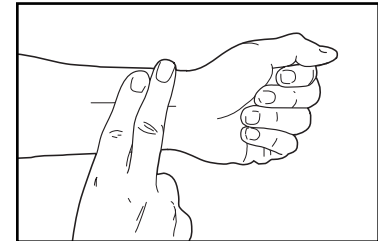

Multiply the result by ten to find your heart rate. (A six-second count is used because your heart rate drops quickly when you stop exercising.) If your heart rate is too high, decrease the intensity of your exercise. If your heart rate is too low, increase the intensity of your exercise.

## WORKOUT GUIDELINES

A well-rounded workout includes three important parts:

**A warm-up**, consisting of 5 to 10 minutes of stretching and light exercise. A proper warm-up increases your body temperature, heart rate, and circulation in preparation for exercise.

**Training zone exercise**, consisting of 20 to 40 minutes of exercising with your heart rate in your training zone. (During the first few weeks of your exercise program, do not keep your heart rate in your training zone for longer than 20 minutes.)

**A cool-down**, with 5 to 10 minutes of stretching. This will increase the flexibility of your muscles and will help to prevent post-exercise problems.

## EXERCISE FREQUENCY

To maintain or improve your condition, plan three workouts each week, with at least one day of rest between workouts. After a few months of regular exercise, you may complete up to five workouts each week, if desired. **Caution: Be sure to progress at your own pace and avoid overdoing it. Incorrect or excessive training may result in injury to your health.**

Remember, the key to success is make exercise a regular and enjoyable part of your everyday life.

Key No.	Qty.	Description	Key No.	Qty.	Description
1	1	Frame	43	2	#4 x 3/8" Screw
2	1	Front Stabilizer	44	1	Reed Switch/Wire
3	1	Rear Stabilizer	45	1	M10 Nylon Jam Nut
4	1	Left Side Shield	46	1	Idler Bushing
5	1	Right Side Shield	47	1	Idler Wheel
6	1	Handlebar Post	48	1	Idler Spacer
7	1	Handlebar	49	1	Idler Arm
8	1	Console Plate	50	1	M10 x 26mm Bolt
9	1	Console	51	1	Idler Spring
10	2	Handlebar Foam	52	1	M10 Nylon Locknut
11	1	Seat Post	53	2	M10 Black Flat Washer
12	1	Seat	54	4	Sealed Bearing
13	2	Round Collar	55	5	M10 Zinc Flat Washer
14	2	Round Bushing	56	8	M8 Black Nylon Locknut
15	2	Handlebar Endcap	57	2	M8 Flat Washer
16	1	Upper Wire Harness	58	2	Adjustment Bracket
17	1	Battery Cover	59	2	Eyebolt
18	7	M8 Flat Washer	60	2	1/4" Nylon Locknut
19	3	M8 x 20mm Button Screw	61	1	Armature
20	6	Console Screw	62	1	Generator Housing
21	10	M4 x 10mm Screw	63	2	M8 x 80mm Carriage Bolt
22	2	Pulse Wire	64	2	Rear Stabilizer Endcap
23	1	1" x 2" Endcap	65	1	Axle Spacer
24	1	Lower Wire Harness	66	1	Reduction Axle
25	6	#8 x 5/16" Screw	67	1	Generator Axle
26	2	M6 x 10mm Screw	68	1	Long Belt
27	4	M8 x 25mm Button Screw	69	1	Short Belt
28	8	M8 Curved Washer	70	1	Control Board
29	4	M6 x 16mm Hex Screw	71	2	Pulse Handle Assembly
30	5	Side Shield Screw	72	2	M8 x 70mm Carriage Bolt
31	1	Seat Knob Assembly	73	1	Generator Bushing
32	2	Crank Bearing	74	1	Reduction Pulley
33	1	Crank	75	1	Roller
34	2	Crank Arm	76	1	Roller Axle
35	2	M8 x 20mm Washer Screw	77	2	M10 Black Nylon Locknut
36	2	Crank Cap	78	3	Armature Bolt
37	1	Right Pedal	79	1	Pulley
38	1	Right Pedal Strap	80	2	Leveling Pad
39	1	Crank Nut	81	1	Magnet
40	1	Left Pedal	#	1	User's Manual
41	1	Left Pedal Strap	#	1	Allen Wrench
42	2	Front Stabilizer Endcap	#	2	Assembly Tool

Note: “#” indicates a non-illustrated part. Specifications are subject to change without notice. See the back cover of this manual for information about ordering replacement parts.

# EXPLODED DRAWING—MODEL NO. RBEX31080

R1198A

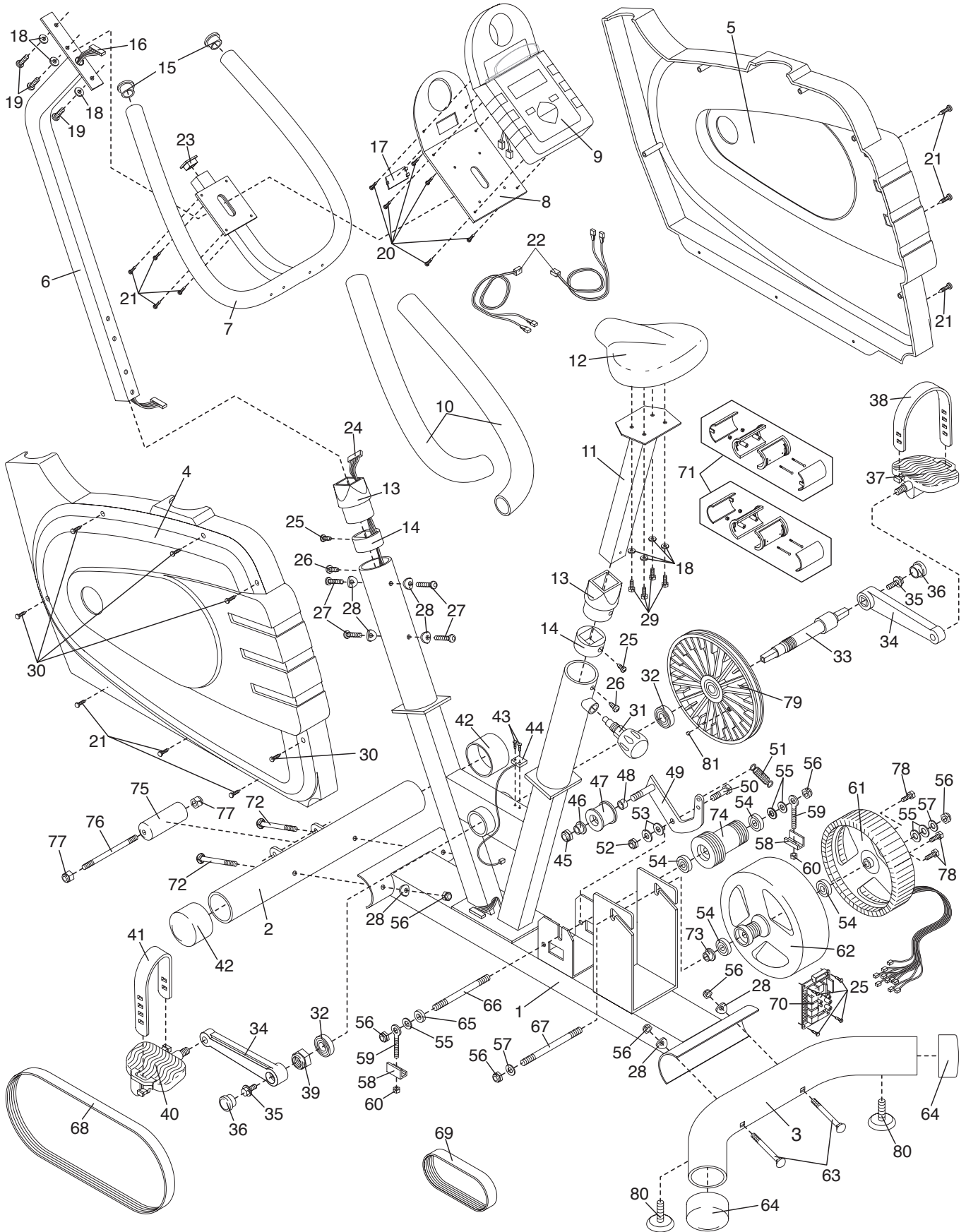

## HOW TO ORDER REPLACEMENT PARTS

To order replacement parts, call our Customer Service Department toll-free at 1-800-999-3756, Monday through Friday, 6 a.m. until 6 p.m. Mountain Time (excluding holidays). To help us assist you, please be prepared to give the following information:

- The MODEL NUMBER of the product (RBEX31080).
- The NAME of the product (REEBOK® CYC4 exercise cycle).
- The SERIAL NUMBER of the product (see the front cover of this manual).
- The KEY NUMBER and DESCRIPTION of the part(s) (see the PART LIST on page 14 of this manual).

REEBOK and the Vector Logo  are registered trademarks and service marks of Reebok. This product is manufactured and distributed under license from Reebok International.

## LIMITED WARRANTY

ICON Health & Fitness, Inc. (ICON), warrants this product to be free from defects in workmanship and material, under normal use and service conditions, for a period of ninety (90) days from the date of purchase. This warranty extends only to the original purchaser. ICON's obligation under this warranty is limited to replacing or repairing, at ICON's option, the product through one of its authorized service centers. All repairs for which warranty claims are made must be pre-authorized by ICON. This warranty does not extend to any product or damage to a product caused by or attributable to freight damage, abuse, misuse, improper or abnormal usage or repairs not provided by an ICON authorized service center, products used for commercial or rental purposes, or products used as store display models. No other warranty beyond that specifically set forth above is authorized by ICON.

ICON is not responsible or liable for indirect, special or consequential damages arising out of or in connection with the use or performance of the product or damages with respect to any economic loss, loss of property, loss of revenues or profits, loss of enjoyment or use, costs of removal, installation or other consequential damages of whatsoever nature. Some states do not allow the exclusion or limitation of incidental or consequential damages. Accordingly, the above limitation may not apply to you.

The warranty extended hereunder is in lieu of any and all other warranties and any implied warranties of merchantability or fitness for a particular purpose is limited in its scope and duration to the terms set forth herein. Some states do not allow limitations on how long an implied warranty lasts. Accordingly, the above limitation may not apply to you.

This warranty gives you specific legal rights. You may also have other rights which vary from state to state.

**ICON HEALTH & FITNESS, INC., 1500 S. 1000 W., LOGAN, UT 84321-9813**