



# OWNER/OPERATOR MANUAL

## TRIMMER ATTACHMENT

### LRT-A

— LRT-A Applicable Model —

- |           |             |             |
|-----------|-------------|-------------|
| BC2601DL  | BCZ2500S/SU | BCZ2600S/SU |
| BCX2600S  | RMSZ2500    | RMNBZ2500   |
| PSZ2500   | BCZ2400     | BCZ3000     |
| BC2300DL* | BC2600DL*   |             |

NOTE: \*marked models - DO NOT USE  
#65 Spacer (6367-13990)

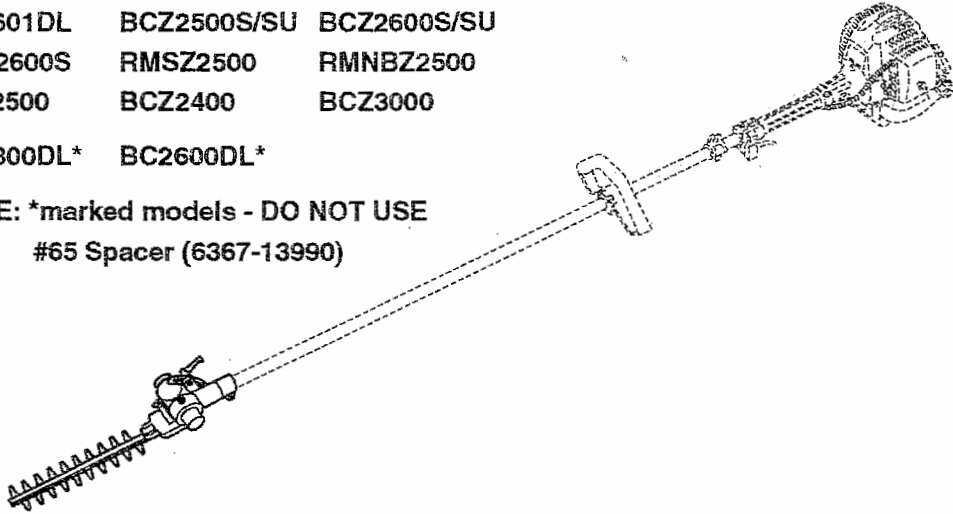

**! WARNING !**  
The engine exhaust from this product contains chemicals known to the State of California to cause cancer, birth defects or other reproductive harm.

**! WARNING !**  
Before using our trimmers, please read this manual carefully to understand the proper use of your unit.

APPLICABLE SERIAL NUMBERS :

CUTTING UNIT 000000 and up

## **INFORMATION**

This machine is equipped with an Overload Cancellation Mechanism.

When the cutting blades have got into metal wires or those twigs difficult to cut, the mechanism acts as a shock absorber, and protects the drive gears and the blades from severe reaction which could give damage to those parts.

When the blades are frequently caught by twigs, please check the following points:

1. Size of the twigs. NEVER TRY TO CUT TWIGS THICKER THAN 3/16" (5mm).
2. Condition of the blade edges. REPLACE THE WORN OUT BLADES.

For the detail of the mechanism, please see below.

Thank you for choosing our product.



## SAFETY FIRST

Instructions contained in warnings within this manual marked with a  symbol concern critical points which must be taken into consideration to prevent possible serious bodily injury, and for this reason you are requested to read all such instructions carefully and follow them without fail.

### ■ WARNINGS IN THE MANUAL

#### WARNING

This mark indicates instructions which must be followed in order to prevent accidents which could lead to serious bodily injury or death.

#### IMPORTANT

This mark indicates instructions which must be followed, or it leads to mechanical failure, breakdown, or damage.

#### NOTE

This mark indicates hints or directions useful in the use of the product.

## CONTENTS

|  |    |
|--|----|
| 1. Parts location .....                | 4  |
| 2. Specifications .....                | 4  |
| 3. Warning labels on the machine ..... | 5  |
| 4. For safe operation .....            | 6  |
| 5. Set up.....                         | 12 |
| 6. Operation .....                     | 13 |
| 7. Maintenance .....                   | 15 |
| 8. Parts list .....                    | 17 |

## 1. Parts location

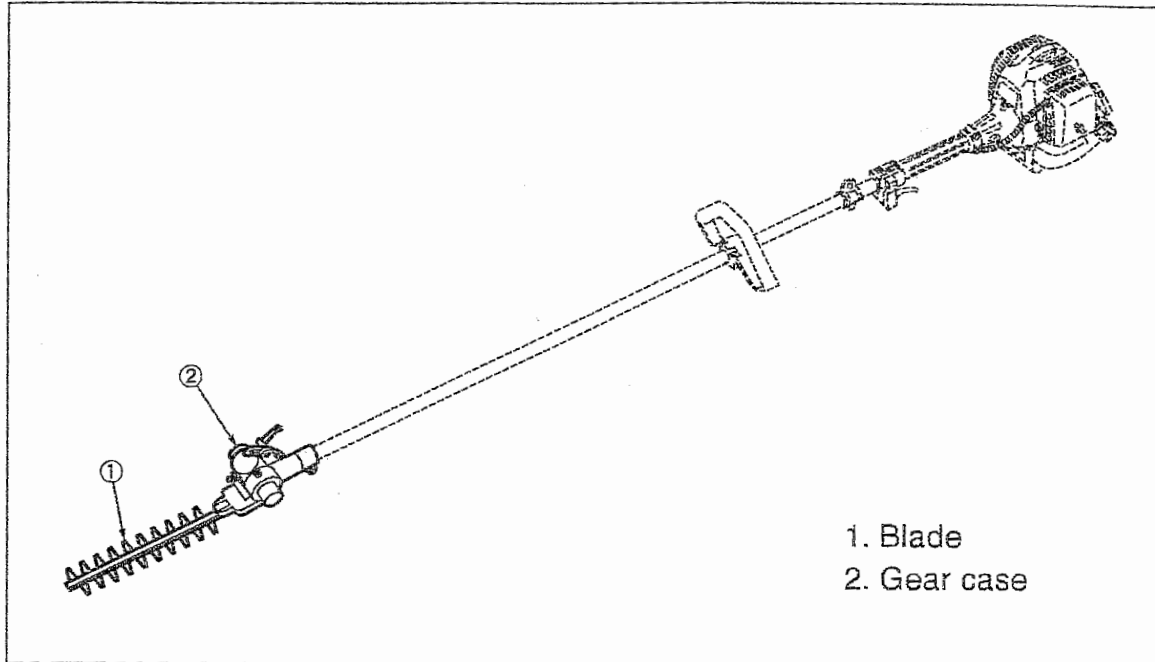

## 2. Specifications

### ■ LRT-A

|              |                          |  |
|--------------|--------------------------|--|
| Cutting head | Type.....                | Reciprocating Double blade                         |
|              | Tooth.....               | 28 teeth   |
|              | Pitch.....               | 30   |
|              | Effective cut width..... | 16 in  |
|              | Angle adjust range.....  | 90°(±45° from cutting head position aligned shaft) |

Specifications are subject to change without notice.

### 3. Warning labels on the machine

---



- (1) Read owner's manual before operating this machine.
- (2) Wear head, eye and ear protection.
- (3) Handling this machine improperly could result in accidents causing serious injury or death. Read this manual carefully and practice using the trimmer until you are fully acquainted with all operations and have learned to use it correctly.
- (4) Keep hands away from cutting blades

#### IMPORTANT

If warning label peel off or become soiled and impossible to read, you should contact the dealer from which you purchased the product to order new labels and affix them in the required location(s).

#### WARNING

Never modify your trimmer.

We won't warrant the machine, if you use the remodeled trimmer or you don't observe the proper usage written in the manual.



## 4. For safe operation

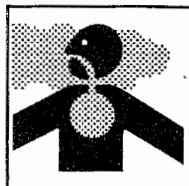
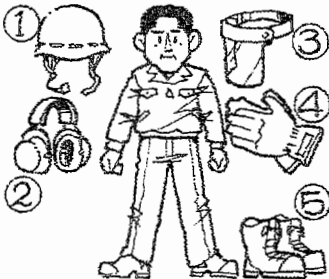

1. Read this manual carefully until you completely understand and follow all safety and operating instructions.
2. Keep this manual handy so that you may refer to it later whenever any questions arise. Also note, if you have any questions which cannot be answered herein, contact the dealer from whom you purchased the product.
3. Always be sure to include this manual when selling, lending, or otherwise transferring the ownership of this product.
4. Never allow children or anyone unable to fully understand the directions given in the manual to use the machine.

### ■ WORKING CONDITION

1. When using the product, you should wear proper clothing and protective equipment.

- (1) Helmet
- (2) Ear protectors
- (3) Protection goggles or face protector
- (4) Thick work gloves
- (5) Non-slip-sole work boots

2. And you should carry with you.
  - (1) Attached tools and files
  - (2) Properly reserved fuel
  - (3) Spare blade
  - (4) Things to notify your working area (rope, warning signs)
  - (5) Whistle (for collaboration or emergency)
  - (6) Hatchet or saw (for removal of obstacles)

3. Do not wear loose clothing, jewelry, short trousers, sandals, or go barefoot. Do not wear anything which might be caught by a moving part of the unit. Secure hair so it is above shoulder length.

### ■ WORKING CIRCUMSTANCE

1. Never start the engine inside a closed room or building. Exhaust gases contain dangerous carbon monoxide.
2. Never use the product,
  - a. when the ground is slippery or when you can't maintain a steady posture.

## 4. For safe operation



b. At night, at times of heavy fog, or at any other times when your field of vision might be limited and it would be difficult to gain a clear view of the working area.

c. During rain storms, during lightning storms, at times of strong or gale-force winds, or at any other times when weather conditions might make it unsafe to use the product.

### WORKING PLAN

1. You should never use the product when under the influence of alcohol, when suffering from exhaustion or lack of sleep, when suffering from drowsiness as a result of having taken cold medicine or at any other time when a possibility exists that your judgment might be impaired or that you might not be able to operate the product properly and in a safe manner.
2. When planning your work schedule, allow plenty of time to rest. Limit the amount of time over which the product is to be used continuously to somewhere around 30~40 minutes per session, and take 10~20 minutes of rest between work sessions. Also try to keep the total amount of work performed in a single day under 2 hours or less.

### WARNING

1. If you don't observe the working time, or working manner (See  USING THE PRODUCT), Repetitive Stress Injury (RSI) could occur.

If you feel discomfort, redness and swelling of your fingers or any other part of your body, see a doctor before getting worse.

2. To avoid noise complaints, in general, operate product between 8a.m. and 5p.m. on weekdays and 9a.m. to 5p.m. weekends.

### NOTE

Check and follow the local regulations as to sound level and hours of operations for the product.



## 4. For safe operation

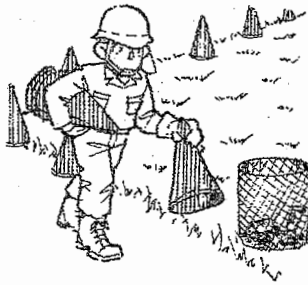

### ■ BEFORE STARTING THE ENGINE

1. The area within a perimeter of 50 feet (15m) of the person using the product should be considered a hazardous area into which no one should enter. If necessary yellow warning rope, warning signs should be placed around the perimeter of the area. When work is to be performed simultaneously by two or more persons, care should also be taken to constantly look around or otherwise check for the presence and locations of other people working so as to maintain a distance between each person sufficient to ensure safety.
2. Check the condition of working area to avoid any accident by hitting hidden obstacles such as stumps, stones, cans, or broken grass.

### ⚠ IMPORTANT

Remove any obstacle before beginning work.

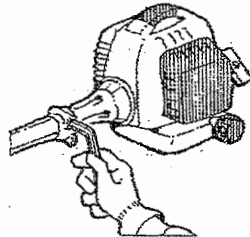

3. Inspect the entire unit for loose fasteners and fuel leakage. Make sure that the cutting attachment is properly installed and securely fastened.
4. Always use the shoulder strap. Adjust the strap for comfort before starting the engine. The strap should be adjusted to fit your body according as your working posture.

### ■ STARTING THE ENGINE

1. Keep bystanders and animals at least 50 feet (15m) away from the operating point. If you are approached, immediately stop the engine.
2. The product is equipped with a centrifugal clutch mechanism, so the cutting attachment begins to rotate as soon as the engine is started by putting the throttle into the start position. When starting the engine, place the product onto the ground in a flat clear area and hold it firmly in place so as to ensure that neither the cutting part nor the throttle come into contact with any obstacle when the engine starts.





## 4. For safe operation

### WARNING

Never place the throttle into the high speed position when starting the engine.

3. After starting the engine, check to make sure that the cutting attachment stops rotating when the throttle is moved fully back to its original position. If it continues to rotate even after the throttle has been moved fully back, turn off the engine and take the unit to your authorized Red Max servicing dealer for repair.

### ■ USING THE PRODUCT

### IMPORTANT

Cut only materials recommended by the manufacturer. And use only for tasks explained in the manual.

1. Grip the handles firmly with both hands using your whole hand. Place your feet slightly apart (slightly further apart than the width of your shoulders) so that your weight is distributed evenly across both legs, and always be sure to maintain a steady, even posture while working.
2. Keep cutting attachment below waist level.
3. Maintain the speed of the engine at the level required to perform cutting work, and never raise the speed of the engine above the level necessary.
4. If the unit start to shake or vibrate, turn off the engine and check the whole unit. Do not use it until the trouble has been properly corrected.
5. Keep all parts of your body away from rotating cutting attachment and hot surfaces.
6. Never touch the muffler, spark plug, or other metallic parts of the engine while the engine is in operation or immediately after shutting down the engine. Doing so could result in serious burns or electrical shock.



## 4. For safe operation

### ◦ IF SOMEONE COMES

1. Guard against hazardous situations at all times. Warn adults to keep pets and children away from the area. Be careful if you are approached. Injury may result from flying debris.
2. If someone calls out or otherwise interrupts you while working, always be sure to turn off the engine before turning around.

### ■ MAINTENANCE

1. In order to maintain your product in proper working order, perform the maintenance and checking operations described in the manual at regular intervals.
2. Always be sure to turn off the engine before performing any maintenance or checking procedures.



### WARNING

The metallic parts reach high temperatures immediately after stopping the engine.

3. When replacing any part, or when replacing the oil or any lubricant, always be sure to **use only RedMax products or products which have been certified by RedMax for use with the RedMax product.**
4. In the event that any part must be replaced or any maintenance or repair work not described in this manual must be performed, please contact a representative from the store nearest RedMax authorized servicing dealer for assistance.
5. Do not use any accessory or attachment other than those bearing the RedMax mark and recommended for the unit.
6. Under no circumstances should you ever take apart the product or alter it in any way. Doing so might result in the product becoming damaged during operation or the product becoming unable to operate properly.



## 4. For safe operation

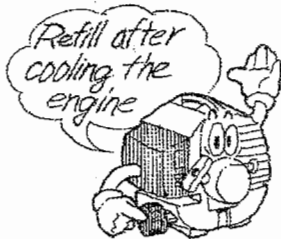

### ■ HANDLING FUEL

1. The engine of the RedMax product is designed to run on a mixed fuel which contains highly flammable gasoline. Never store cans of fuel or refill the tank of the unit in any place where there is a boiler, stove, wood fire, electrical sparks, welding sparks, or any other source of heat or fire which might ignite the fuel.
2. Never smoke while operating the unit or refilling its fuel tank.
3. When refilling the tank, always turn off the engine and allow it to cool down. Take a careful look around to make sure that there are no sparks or open flames anywhere nearby before refueling.
4. Wipe spilled fuel completely using a dry rag if any fuel spillage occurs during refueling.
5. After refueling, screw the fuel cap back tightly onto the fuel tank and then carry the unit to a spot 10 feet or more away from where it was refueled before turning on the engine.

### ■ TRANSPORTATION

1. When hand-carrying the product, cover over the cutting part, lift up the product and carry it paying attention to the blade.
2. Never transport the product over rough roads over long distances by vehicle without removing all fuel from the fuel tank. If doing so, fuel might leak from the tank during transport.

## 5. Set up

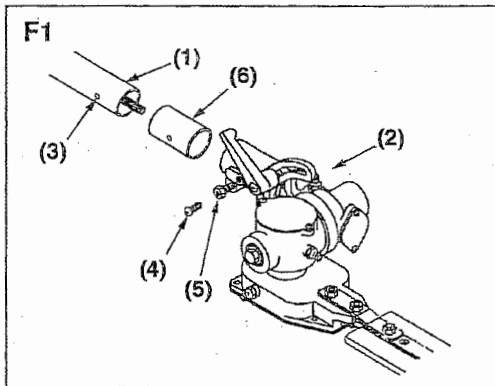

### ■ ATTACHING THE TRIMMING MECHANISM (F1)

1. Remove the cap on the end of the main pipe.
2. Remove the screw screwed into the end of the trimming mechanism.
3. When attaching to LRTZ2500 BC2601DL BCZ2500S/SU BCX2600S RMSZ2500 SGCZ2500S SGCX2600S and PSZ2500, insert the spacer into the trimmer mechanism as aligning the screw holes of the both.
4. Insert the end of the trimming mechanism into the main pipe.
5. Line up the hole on the end of the trimming mechanism into which the screw is to be inserted with the hole on the main pipe, and screw the screw firmly in.
6. Using a 10-mm wrench, screw in the hexagonal bolt provided to fix the trimming mechanism into place.

- (1) Main pipe
- (2) Trimming mechanism
- (3) Screw hole
- (4) Screw
- (5) Fastening bolt
- (6) Spacer

## 6. Operation

---

### **⚠ WARNING**

This product is equipped with extremely sharp blades, and when used improperly these blades can be extremely dangerous, and improper handling can cause accidents which may in turn lead to serious injury or death. For this reason, you should always be careful to follow the following instructions when using your trimmer.

- Never hold the trimmer in a way in which the blades are pointed towards someone else.
- Never allow the blades to come into proximity with your body while the engine of the trimmer is in operation.
- Always be sure to turn off the engine before changing the angle of the blades, removing branches which have become stuck in the blades, or at any other time when coming into close proximity with the blades.
- Always wear work gloves made of leather or some other sturdy material when using the trimmer.
- Always place the blade cover provided with the trimmer over the blades when not in use.
- **Falling branches may fall onto the face or into the eyes, resulting in injuries, scratches, and cuts, and for this reason you should always be sure to wear a helmet and face protector when using your trimmer.**



### **⚠ IMPORTANT**

The thickness of branches which may be cut using this trimmer is limited to up to approximately 3/16" (5mm). Never try to cut branches thicker than this, as doing so may result in damage to the trimmer.

## 8. Operation

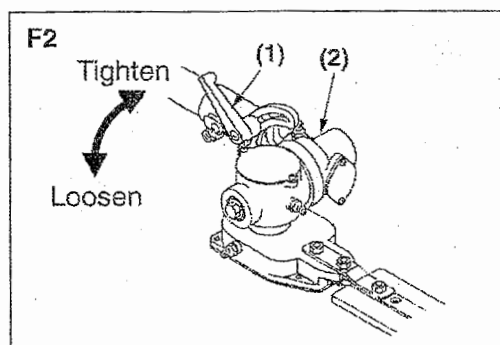

### ■ ADJUSTING THE ANGLE OF THE CUTTING BLADES (F2)

1. Stop the engine.
2. Turn the bolt located on the top of the trimming mechanism counter-clockwise to loosen it.
3. Adjust the angle of the blades to the desired angle, and then fix the bolt firmly back into place.

(1) Clamp lever

(2) Trimming mechanism

# 7. Maintenance

## ■ MAINTENANCE CHART

|       | system/component  | procedure                    | before use | every 25 hours after | every 50 hours after | every 100 hours after | note                 |
|-------|-------------------|------------------------------|------------|----------------------|----------------------|-----------------------|----------------------|
| SHAFT | cutting parts     | replace if something's wrong | ✓          |                      |                      |                       |                      |
|       | gear case         | grease                       |            | ✓                    |                      |                       |                      |
|       | screws/nuts/bolts | tighten/replace              | ✓          |                      |                      | ✓                     | not adjusting screws |

### ■ BLADES (F3)

- When refilling the tank or resting, it is often a good idea to use the time to oil the cutting blades.
- If a gap exists between the upper and lower blades, follow the procedure below to adjust them so that they fit more closely together.

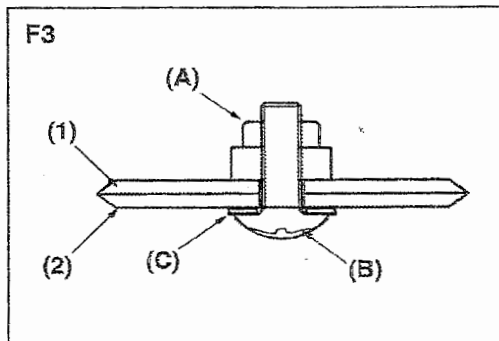

1. Loosen lock nut (A) as shown in the diagram.
2. Tighten screw (B) fully, and then turn one-third to one-half of a rotation backward.
3. While holding onto the screw to keep it in position, tighten the lock nut.
4. Check to make sure that the flat washer (C) is loose enough so that it may be turned by pressing on it with a finger.

- (1) Upper blade  
(2) Lower blade

### NOTE

Screwing in the screw too tightly may make it impossible for the blades to move. Conversely, not screwing in the screw tightly enough may make the blades of the trimmer feel dull and cause leaves and branches to become caught in the blades of the trimmer.

## 9. Maintenance

---

### QUICK TIP

If the blades become so worn down that it is no longer possible to eliminate the gap between them, you should contact the authorized RedMax servicing dealer from which you purchased your RedMax® trimmer to have the blades resharpened or replaced.

### ■ GEAR CASE

The reduction gears are lubricated by multipurpose, lithium-based grease in the gearcase.

Supply new grease every 25 hours of use or more often depending on the job condition.

When adding lubricant, use a grease gun to insert lubricant into the three grease nipples located on the gear case. (F4)

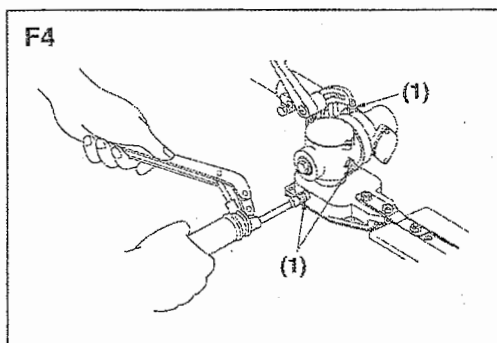

(1) Grease fitting



### TRIMMER ATTACHMENT

## LRT-A

**NOTE :**

1. Use KOMATSU ZENOAH genuine parts as specified in the parts list for repair and/or replacement.
2. KOMATSU ZENOAH does not warrant the machines, which have been damaged by the use of any parts other than those specified by the company.
3. When placing parts orders for repair and/or replacement, check if the model name and the serial number are applicable to those specified in the parts list, then use parts number described in the parts list.
4. The contents described in the parts list may change due to improvement.
5. The parts for the machine shall be supplied seven (7) years after the machine is discontinued. [It is possible that some specific parts may be subject to change of their delivery term and list price within the limit of ten (7) years after the machine is discontinued. It is also possible that some parts may be available even after the limit of seven (7) years.]

APPLICABLE SERIAL NUMBERS :

CUTTING UNIT 000000 and up

Dec.1999

## 8. Parts list

Fig.1 CUTTING UNIT LRT-A (S/N 000000 and up)

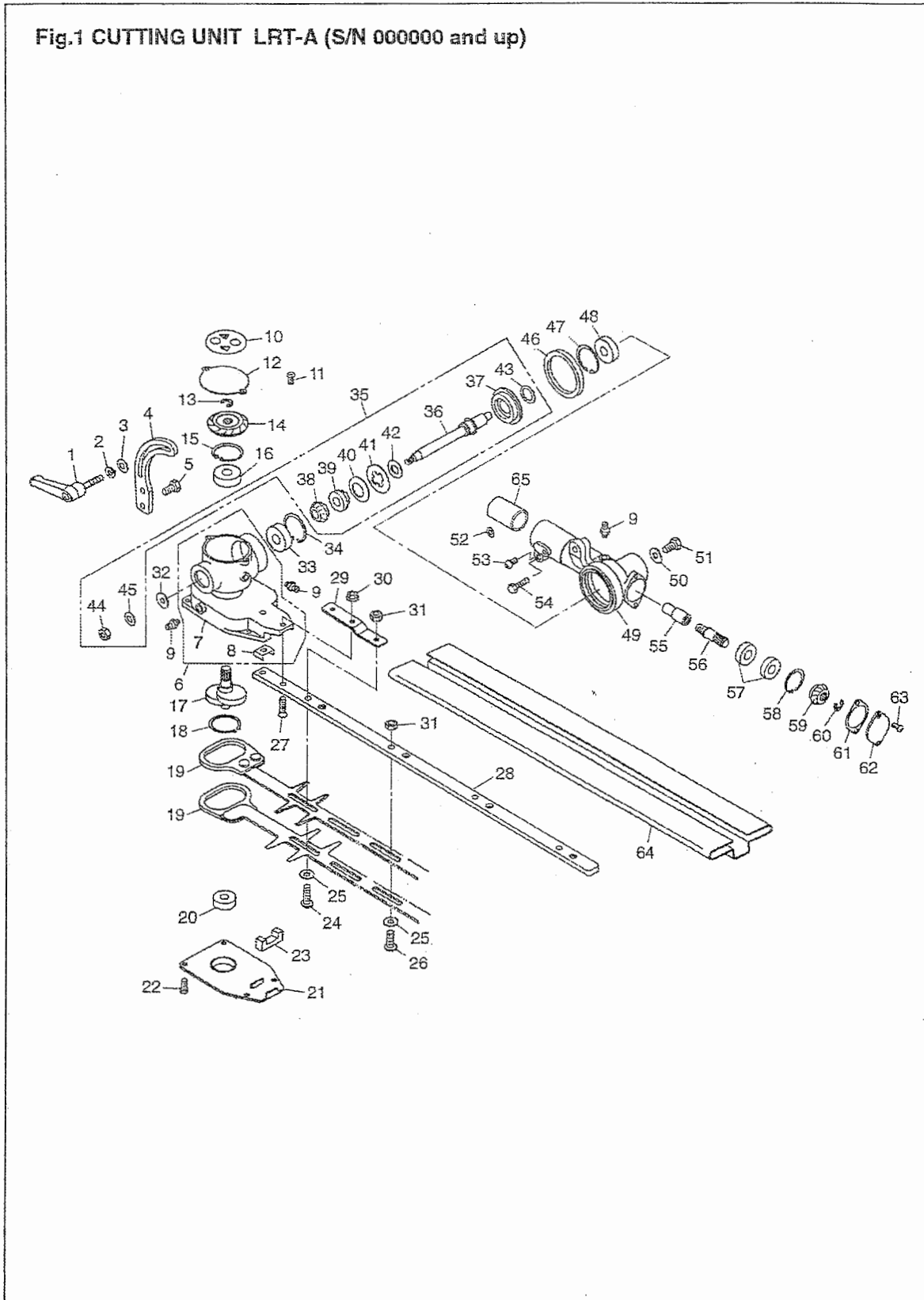

Fig.1 CUTTING UNIT LRT-A (S/N 000000 and up)

| Key# | Description     | Part Number | Q'ty | Key# | Description    | Part Number | Q'ty |
|------|-----------------|-------------|------|------|----------------|-------------|------|
| 1    | LEVER, clamp    | 6598-13110  | 1    | 53   | BOLT M5x10     | 01252-30510 | 1    |
| 2    | WASHER M6       | 0290-20615  | 1    | 54   | BOLT M5x30     | 3350-21320  | 1    |
| 3    | WASHER 6x16x2.0 | 6598-13130  | 1    | 55   | JOINT          | 6782-13810  | 1    |
| 4    | ANGLE ADJUSTER  | 6782-13140  | 1    | 56   | GEAR SHAFT B   | 6598-13820  | 1    |
| 5    | BOLT M6x12      | 0225-10612  | 2    | 57   | BEARING 6900RS | 6782-13830  | 2    |
| 6    | CASING A SET    | 6782-13200  | 1    | 58   | SNAP RING      | 04065-02212 | 1    |
| 7    | • CASING A      | _____       | 1    | 59   | BEVEL GEAR     | 6782-13850  | 1    |
| 8    | • PLATE         | 6782-13220  | 1    | 60   | SNAP RING      | 6598-13330  | 1    |
| 9    | GREESE FITTING  | 3199-13350  | 3    | 61   | PACKING        | 6598-13860  | 1    |
| 10   | LABEL           | 6782-13250  | 1    | 62   | COVER          | 6598-13870  | 1    |
| 11   | SCREW M4x8      | 0263-10408  | 2    | 63   | SCREW M4x8     | 0263-10408  | 2    |
| 12   | COVER           | 6598-13320  | 1    | 64   | BLADE COVER    | 6782-13910  | 1    |
| 13   | SNAP RING       | 6598-13330  | 1    | 65   | SPACER         | 6367-13990  | 1    |
| 14   | BEBEL GEAR      | 6782-13340  | 1    |      |                |             |      |
| 15   | SNAP RING       | 04065-02612 | 1    |      |                |             |      |
| 16   | BEARING         | 06004-06000 | 1    |      |                |             |      |
| 17   | CRANK SHAFT     | 6782-13370  | 1    |      |                |             |      |
| 18   | SNAP RING       | 04064-02815 | 1    |      |                |             |      |
| 19   | BLADE           | 6782-13411  | 2    |      |                |             |      |
| 20   | BEARING 608Z    | 6782-13430  | 1    |      |                |             |      |
| 21   | COVER           | 6782-13440  | 1    |      |                |             |      |
| 22   | BOLT M4x10      | 6782-13450  | 4    |      |                |             |      |
| 23   | FELT            | 6782-13460  | 1    |      |                |             |      |
| 24   | SCREW           | 3884-11750  | 1    |      |                |             |      |
| 25   | WASHER          | 3880-11780  | 4    |      |                |             |      |
| 26   | SCREW L17       | 6598-13510  | 3    |      |                |             |      |
| 27   | SCREW M5x20     | 6598-13530  | 2    |      |                |             |      |
| 28   | GUIDE PLATE     | 6782-13540  | 1    |      |                |             |      |
| 29   | PLATE           | 6782-13550  | 1    |      |                |             |      |
| 30   | NUT M5          | 6782-14470  | 2    |      |                |             |      |
| 31   | NUT M6          | 3880-11790  | 4    |      |                |             |      |
| 32   | WASHER 6x15x2.0 | 6782-13650  | 1    |      |                |             |      |
| 33   | BEARING 608 2RS | 6598-13430  | 1    |      |                |             |      |
| 34   | SNAP RING       | 04065-02212 | 1    |      |                |             |      |
| 35   | SHAFT KIT       | T4008-06010 | 1    |      |                |             |      |
| 36   | •• SHAFT        | _____       | 1    |      |                |             |      |
| 37   | •• GEAR(B)      | _____       | 1    |      |                |             |      |
| 38   | •• GEAR(C)      | T4008-13630 | 1    |      |                |             |      |
| 39   | •• BOSS         | _____       | 1    |      |                |             |      |
| 40   | •• SPRING       | T4008-13650 | 1    |      |                |             |      |
| 41   | •• PLATE        | T4008-13660 | 1    |      |                |             |      |
| 42   | •• WASHER       | T4008-13670 | 1    |      |                |             |      |
| 43   | •• WASHER       | T4008-13680 | 1    |      |                |             |      |
| 44   | • NUT M6        | 0280-10605  | 1    |      |                |             |      |
| 45   | • WASHER        | 0290-20615  | 1    |      |                |             |      |
| 46   | O-RING P41      | 6598-13620  | 1    |      |                |             |      |
| 47   | SNAP RING       | 04065-02612 | 1    |      |                |             |      |
| 48   | BEARING         | 06004-06000 | 1    |      |                |             |      |
| 49   | CASING B        | 6782-13710  | 1    |      |                |             |      |
| 50   | WASHER 6x16x2.0 | 6598-13130  | 1    |      |                |             |      |
| 51   | BOLT M6x12      | 0225-10612  | 1    |      |                |             |      |
| 52   | WASHER 5x10x1.0 | 6782-13720  | 1    |      |                |             |      |

**RedMax**  
**LIMITED WARRANTY**

For LRT-A when used as an attachment on units listed on the cover of this manual.

FOR 90 DAYS FROM THE DATE OF ORIGINAL PURCHASE, THE COMPANY, THROUGH ANY RedMax DEALER, WILL REPAIR OR REPLACE, FREE OF CHARGE, FOR THE ORIGINAL PURCHASER, ANY PART OF PARTS FOUND TO BE DEFECTIVE IN MATERIAL AND/OR WORKMANSHIP. THIS IS THE EXCLUSIVE REMEDY.

THE PURCHASER SHALL BEAR COSTS OF TRANSPORTING THE UNIT TO AND FROM THE RedMax DEALER.

THE PURCHASER SHALL NOT BE CHARGED FOR DIAGNOSTIC LABOR WHICH LEADS TO THE DETERMINATION THAT A WARRANTED PART IS DEFECTIVE, IF THE DIAGNOSTIC WORK IS PERFORMED AT THE RedMax DEALER.

THE PURCHASER OR OWNER IS RESPONSIBLE FOR THE PERFORMANCE OF THE REQUIRED MAINTENANCE AS DEFINED BY THE MANUFACTURER IN THE OWNER/OPERATOR MANUAL.

ANY WARRANTED PART WHICH IS NOT SCHEDULED FOR REPLACEMENT AS REQUIRED MAINTENANCE, OR WHICH IS SCHEDULED ONLY FOR REGULAR INSPECTION TO THE EFFECT OF "REPAIR OR REPLACE AS NECESSARY" SHALL BE WARRANTED FOR THE WARRANTY PERIOD. ANY WARRANTED PART WHICH IS SCHEDULED FOR REPLACEMENT AS REQUIRED MAINTENANCE SHALL BE WARRANTED FOR THE PERIOD OF TIME UP TO THE FIRST SCHEDULED REPLACEMENT POINT FOR THE PART.

ANY REPLACEMENT PART THAT IS EQUIVALENT IN PERFORMANCE AND DURABILITY MAY BE USED IN NON-WARRANTY MAINTENANCE OR REPAIRS, AND SHALL NOT REDUCE THE WARRANTY OBLIGATION OF THE COMPANY.

THE WARRANTY DOES NOT APPLY TO THOSE UNITS WHICH HAVE BEEN DAMAGED BY NEGLIGENCE OF INSTRUCTION LISTED IN THE OWNER/OPERATOR MANUAL FOR PROPER USE AND MAINTENANCE OF THE UNITS, ACCIDENTAL MISHANDLING, ALTERATION, ABUSE, IMPROPER LUBRICATION, USE OF ANY PARTS OR ACCESSORIES OTHER THAN THOSE SPECIFIED BY THE COMPANY, OR OTHER CAUSES BEYOND THE COMPANY'S CONTROL.

THIS WARRANTY DOES NOT COVER THOSE PARTS REPLACED BY NORMAL WEAR OR HARMLESS CHANGES IN THEIR APPEARANCE.

THERE ARE NO OTHER EXPRESS WARRANTIES.

IMPLIED WARRANTIES INCLUDING THOSE OF MERCHANTABILITY AND FITNESS FOR A PARTICULAR PURPOSE ARE LIMITED TO 90 DAYS OF USE FROM THE ORIGINAL DELIVERY DATE.

LIABILITIES FOR INCIDENTAL OR CONSEQUENTIAL DAMAGE UNDER ANY AND ALL WARRANTIES ARE EXCLUDED.

SOME STATES DO NOT ALLOW LIMITATION ON HOW LONG AN IMPLIED WARRANTY LASTS OR EXCLUSION OR LIMITATION OF INCIDENTAL OR CONSEQUENTIAL DAMAGES, SO THE ABOVE LIMITATION OR EXCLUSION MAY NOT APPLY TO YOU.

THIS WARRANTY GIVES YOU SPECIFIC LEGAL RIGHTS, AND YOU MAY ALSO HAVE OTHER RIGHTS WHICH VARY FROM STATE TO STATE.

IF YOU NEED TO OBTAIN INFORMATION ABOUT THE NEAREST SERVICE CENTER, PLEASE CALL KOMATSU ZENOAH AMERICA INC. AT (770)-381-5147.

**IMPORTANT:** YOU WILL RECEIVE A WARRANTY REGISTRATION CARD AT TIME OF PURCHASE. PLEASE FILL OUT THE CARD AND SEND IT TO RedMax / KOMATSU ZENOAH AMERICA WITHIN SEVEN (7) DAYS. BE SURE TO KEEP A COPY FOR YOUR RECORDS.



KOMATSU ZENOAH AMERICA INC.  
4344 Shackleford Road Suite 500  
Norcross, Georgia 30093

## RedMax Garantie limitée

Para LRT-A cuando se utilice un aditamento  
en las unidades detalladas en la cubierta de este manual.

90 jours à compter de la date d'achat initial. La société, par l'intermédiaire d'un distributeur RedMax, réparera ou remplacera toute(s) pièce(s), sans frais et au bénéfice de l'acheteur original, en prenant en charge les frais de pièces et/ou de main d'œuvre. **Telles sont les limites de la garantie.**

Le coût du transport de l'unité jusqu'au revendeur RedMax et depuis celui-ci sera à la charge de l'acheteur.

L'acheteur ne supportera pas le coût de main d'œuvre du diagnostic qui amène à la conclusion qu'une pièce garantie est défectueuse, si ce diagnostic est effectué chez le revendeur RedMax.

L'acheteur ou propriétaire a pour responsabilité d'effectuer l'entretien obligatoire tel que défini par le fabricant dans le manuel du propriétaire/de l'utilisateur.

Toute pièce garantie dont le remplacement n'est pas prévu dans le cadre de l'entretien obligatoire, ou pour laquelle est seulement prévue une inspection périodique pour "remplacement ou réparation si nécessaire" sera garantie pour la période de garantie. Toute pièce garantie arrivée à l'échéance de son premier remplacement prévu sera garantie jusqu'à celui-ci.

Toute pièce de rechange équivalente en performance ou en durabilité peut être utilisée pour l'entretien hors-garantie ou les réparations hors-garantie, et ce sans réduire l'obligation de garantie incombant à la société.

**La garantie ne s'applique pas** aux unités endommagées par suite de: négligence dans la mise en oeuvre des instructions spécifiées dans le manuel du propriétaire/de l'utilisateur en vue d'une utilisation et d'un entretien correct, fausse manœuvre accidentelle, modification, utilisation abusive, lubrification incorrecte, utilisation de pièces ou d'accessoires autres que ceux spécifiés par la société, ou autres causes hors du contrôle de la société.

**Cette garantie ne couvre pas** les pièces remplacées en raison de leur usure normale ou de changements d'apparence sans effets.

Il n'existe aucune autre garantie explicite.

**Les garanties implicites**, y compris la valeur marchande et la valeur d'usage pour une utilisation particulière, sont limitées à 90 jours d'utilisation à compter de la date originale de livraison.

**Les responsabilités pour les dommages conséquents ou incidents sont exclues de toutes les garanties.**

Certaines provinces n'autorisant pas les limitations à la durée des garanties implicites, ou les exclusions ou limitations relatives aux dommages incidents ou conséquents, la limitation indiquée ci-dessus peut ne pas vous être applicable.

Cette garantie vous donne des droits juridiques spécifiques, et vous pouvez également jouir d'autres droits variant d'une province à l'autre.

Si vous désirez obtenir des informations sur le centre de service le plus proche, veuillez appeler KOMATSU ZENOAH AMERICA INC. au (770)-381-5147

**Note importante:** vous recevrez une carte d'enregistrement de garantie au moment de l'achat. Veuillez la remplir et l'adresser à RedMax / KOMATSU ZENOAH AMERICA sous sept (7) jours en prenant soin de conserver une copie pour vous.



**KOMATSU ZENOAH AMERICA INC.**  
4344 Shackleford Road Suite 500  
Norcross, Georgia 30093