

OPERATING AND INSTALLATION INSTRUCTIONS

Models
155C

VERSA SWIMMING POOL and SPA HEATER



WARNING: If the information in these instructions are not followed exactly, a fire or explosion may result causing property damage, personal injury or death.

- Do not store or use gasoline or other flammable vapors and liquids in the vicinity of this or any other appliance.
- **WHAT TO DO IF YOU SMELL GAS**
 - Do not try to light any appliance.
 - Do not touch any electrical switch; do not use any phone in your building.
 - Immediately call your gas supplier from a neighbor's phone. Follow the gas supplier's instructions.
 - If you cannot reach your gas supplier, call the fire department.
- Installation and service must be performed by a qualified installer, service agency or the gas supplier.

This manual should be maintained in legible condition and kept adjacent to the heater or kept in a safe place for future reference.



Raypak®

CONTENTS

3	PART ONE - Owner's Operating Instructions
3	SECTION 1 / START-UP PROCEDURES
3	Before Start-Up
4	Lighting Instructions & Shut-Off Procedures (Manually Lighted Pilot MV)
5	Operating Instructions & Shut-Off Procedures (Automatically Lighted Pilots IID)
6	After Start-Up
6	SECTION 2 / CAUTION
7	SECTION 3 / MAINTENANCE & CARE PROCEDURES
7	Pool & Spa Water Chemistry
8	Cold Weather Operation
8	Winterizing The Pool And Spa Heater
9	PART TWO - INSTALLATION/SERVICE INSTRUCTIONS
9	SECTION 1 / RECEIVING EQUIPMENT
9	SECTION 2 / GENERAL SPECIFICATIONS
9	SECTION 3 / INSTALLATION INSTRUCTIONS
7	Code Requirements
9	Base Installation
10	Clearances
12	Combustion Air
12	Venting Connections
14	Gas Supply Connections
15	Plumbing For Water Connections
17	Electrical Wiring
21	SECTION 4 / SERVICING INSTRUCTIONS
21	General Location Of Controls
21	Control Adjustments / Replacements
22	Pressure Switch
22	High Limit Removal
22	Flame Roll-Out Safety Switch
23	Pilot Safety (MV Units)
23	Pilot Safety (IID Units)
23	Gas Valve Removal
23	Main Burner & Orifice Removal
23	Pilot Removal & Cleaning
24	Heat Exchanger Removal
24	Control Immersion Well Replacement
24	Tube Cleaning Procedure (Typical)
25	Tube Replacement Procedure
25	Desooting Procedure
25	Combustion Chamber Removal
26	SECTION 5 / TROUBLESHOOTING GUIDE
26	Mechanical
28	Electrical IID Units
30	SECTION 6 / REPLACEMENT PARTS

PART ONE - OWNER'S OPERATING INSTRUCTIONS

FOR YOUR SAFETY - READ BEFORE OPERATING

WARNING: IF YOU DO NOT FOLLOW THESE INSTRUCTIONS EXACTLY, A FIRE OR EXPLOSION MAY RESULT, CAUSING PROPERTY DAMAGE, PERSONAL INJURY OR LOSS OF LIFE.

SECTION 1 / START-UP PROCEDURES

BEFORE START-UP

BURNERS

Clean main burners and air louvers of dust, lint and debris. Keep heater area clear and free from combustibles, flammable liquids and chemicals. Do not obstruct the flow of combustion and ventilating air.

WATER

Water must be flowing through the heater during operation. Insure that system is filled with water and have pump operating.

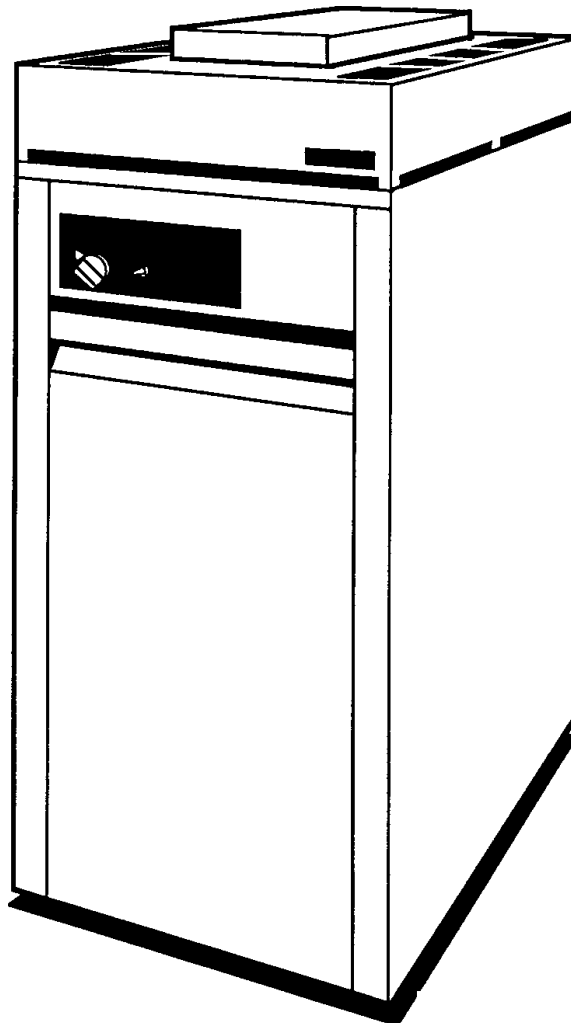

Fig. # 8111.0

CAUTION: Propane gas is heavier than air and will settle on the ground. Since propane can accumulate in confined areas, extra care should be exercised when lighting propane heaters.

LIGHTING INSTRUCTIONS AND SHUT-OFF PROCEDURES

**MANUALLY LIGHTED PILOTS
MILLIVOLT SYSTEM**

- A. This appliance has a pilot that must be lighted by hand. When lighting the pilot, follow these instructions exactly.
- B. BEFORE LIGHTING smell all around the appliance area for gas. Be sure to smell next to the floor because some gas is heavier than air and will settle on the floor.

*If you cannot reach your gas supplier, call the fire department.

- C. Use only your hand to push in or turn the gas control knob. Never use tools. If the knob will not push in or turn by hand, do not try to repair it. Call qualified service technician. Force or attempted repair may result in a fire or explosion.

WHAT TO DO IF YOU SMELL GAS:

- *Do not try to light any appliance.
- *Do not touch any electric switch; do not use any phone in your building.
- *Immediately call your gas supplier from a neighbor's phone. Follow the gas suppliers' instructions.

- D. Do not use this appliance if any part has been under water. Immediately call a qualified service technician to inspect the appliance and to replace any part of the control system and any gas control which has been underwater.

LIGHTING INSTRUCTIONS

1. **STOP!** Read the safety information above.
2. Set the thermostat on the lowest setting.
3. Turn On/Off switch to the "Off" position.
4. Remove heater door panel.
5. Push in gas control knob slightly and turn clockwise to "Off".

NOTE: Knob cannot be turned from "Pilot" to "Off" unless knob is pushed in slightly. Do not force.

6. Wait 5 minutes to clear out any gas. If you then smell gas, **STOP!** Follow "B" in the safety information above. If you don't smell gas, go to the next step.
7. Locate pilot mounted on the right side panel of the burner drawer. For burner drawer location, see location of control section, page 22.

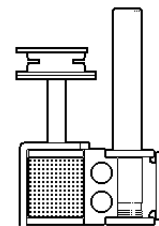

Robertshaw Pilot

Honeywell Pilot

Fig. #8045.1

Fig. #8083.0

8. Turn knob on gas control counter-clockwise to "Pilot".
9. Push in control knob all the way and hold it in. Immediately place flame to end of pilot tube to light pilot. Continue to hold control knob in for about 1 minute after the pilot is lighted, release knob and it will pop back up. Pilot should remain lighted. If it goes out, repeat steps 5 through 9.

*If knob does not pop up when released, stop and immediately call your service technician or gas supplier.

*If the pilot does not stay lit after several tries, turn the gas control knob to "Off" and call your service technician or gas supplier.

10. Stand to the side of the heater and turn the gas control knob counter-clockwise to "On".
11. Replace heater door panel.
12. Turn On/Off switch to the "On" position.
13. Set thermostat to the desired setting.

GAS CONTROL KNOBS SHOWN IN "OFF" POSITION.

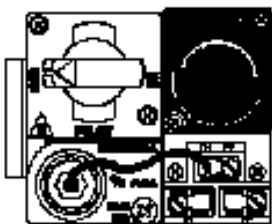

**Honeywell Gas Valve
Millivolt**

Fig. #8081.0

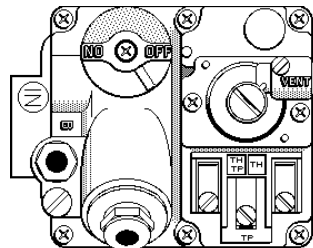

**Robertshaw Gas Valve
Millivolt**

Fig. #8079.0

TO TURN OFF GAS TO APPLIANCE

1. Set the thermostat to the lowest setting.
2. Turn On/Off switch to the "Off" position.
3. Remove heater door panel.
4. Push the gas control knob slightly and turn clockwise to "Off". Do not force.
5. Replace heater door panel.

CAUTION: Propane gas is heavier than air and will settle on the ground. Since propane can accumulate in confined areas, extra care should be exercised when lighting propane heaters.

OPERATING INSTRUCTIONS AND SHUT-OFF PROCEDURES

AUTOMATICALLY LIGHTED PILOTS ELECTRONIC IGNITION SYSTEMS

- A. This appliance is equipped with an ignition device which automatically lights the pilot. Do not try to light the pilot by hand.
- B. BEFORE OPERATING, smell all around the appliance area for gas. Be sure to smell next to the floor because some gas is heavier than air and will settle on the floor.
- WHAT TO DO IF YOU SMELL GAS:**
 *Do not try to light any appliance.
 *Do not touch any electric switch; do not use any phone in your building.
 *Immediately call your gas supplier from a neighbor's phone. Follow the gas supplier's instructions.
- C. Use only your hand to push in or turn the gas control knob. Never use tools. If the knob will not push in or turn by hand, don't try to repair it; call a qualified service technician. Force or attempted repair may result in fire or explosion.
- D. Do not use this appliance if any part has been underwater. Immediately call a qualified service technician to inspect the appliance and to replace any part of the control system and any gas control which has been underwater.
- *If you cannot reach your gas supplier, call the fire department.

OPERATING INSTRUCTIONS

1. **STOP!** Read the safety information above.
2. Set the thermostat to the lowest setting.
3. Turn off all electric power to the appliance.
4. This appliance is equipped with an ignition device which automatically lights the pilot. Do not try to light the pilot by hand.
5. Remove heater door panel.
6. **For Honeywell valve:** Push in gas control knob slightly and turn clockwise to "Off". Knob cannot be turned to "Off" unless it is pushed in slightly. Do not force.
For Robertshaw valve: Push in and move gas control lever counter-clockwise to "OFF" position.
7. Wait 5 minutes to clear out any gas. If you then smell gas, **STOP!** Follow "B" in the safety information previously stated. If you don't smell gas, go to the next step.
8. Turn gas control knob counter-clockwise to "On" (Honeywell).
 Move gas control lever clockwise to "ON" position (Robertshaw).
9. Replace heater door panel.

GAS CONTROL KNOBS
SHOWN IN "ON" POSITION →

**Honeywell
Gas Valve
IID**

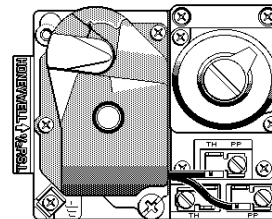
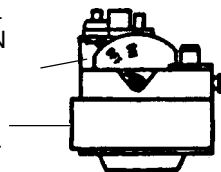

Fig. # 8082.0

GAS CONTROL
LEVER SHOWN
IN "OFF" POSI-
TION

GAS INLET



**Robertshaw
Gas Valve
IID**

10. Turn on all electrical power to appliance.
11. Set thermostat to desired setting.
12. If the appliance will not operate, follow the instructions "To Turn Off Gas To Appliance" and call your service technician or gas supplier.

TO TURN OFF GAS TO APPLIANCE

1. Set the thermostat at the lowest setting.
2. Turn off all the electric power to the appliance if service is to be performed.
3. Remove heater door panel.
4. **For Honeywell valve:** Push in gas control knob slightly and turn clockwise to "Off".
For Robertshaw valve: Push in and move gas control lever counter-clockwise to "OFF" position.
5. Replace heater door panel.

AFTER START-UP

Feel the inlet and outlet pipes. Outlet pipe should be only slightly warmer than the inlet. It should not be hot.

WARNING: Should overheating occur or the gas supply fail to shut off, turn off the manual gas control valve to the appliance.

VISUAL INSPECTION

With the heater on, remove the door and make a visual check of the pilot and burner. The flame should be blue with a well-defined pattern.

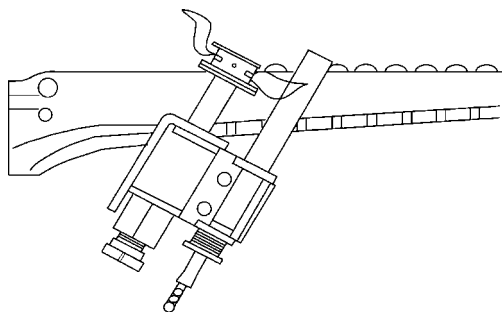
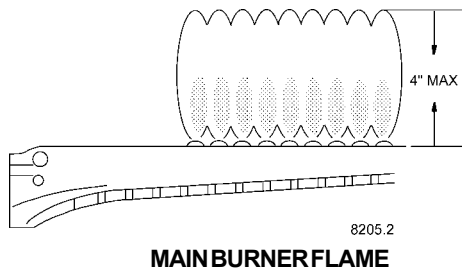

Fig. # 8964

PILOT BURNER FLAME

A yellow or "floating" flame indicates restricted air openings or incorrect orifice size. Should this occur, shut the heater off and contact your installer or gas supplier.

WATER PRESSURE SWITCH

A water pressure switch is provided in the heater to shut off the burners in the event that water supply to the heater is interrupted. It is very important to verify that the switch electrically opens and shuts off the gas valve when water flow to the heater is interrupted. Otherwise, rapid and severe damage will likely occur to the heater. (The water pressure switch should be checked and adjusted for proper operation by a qualified service person at the time of installation and periodically checked thereafter. Refer to pressure switch servicing instruction in Section 4 of this manual).

WARNING: Operation of the heater without water circulation will cause rapid and severe damage to the heater.

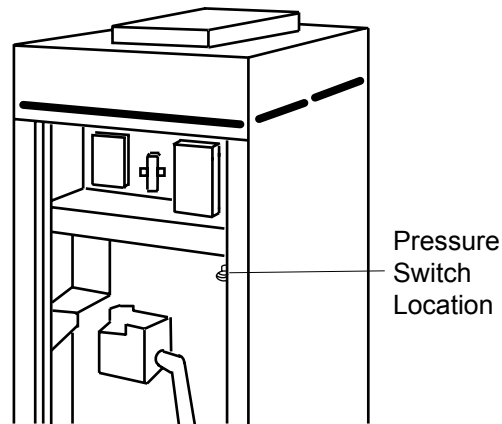

Fig. # 8110.1

SECTION 2 / CAUTION

Elevated water temperature can be hazardous, and the U.S. Consumer Product Safety Commission recommends the following guidelines:

1. Spa or hot tub water temperatures should never exceed 104°F (40°C). A temperature of 100°F (38°C) is considered safe for a healthy adult. Special caution is suggested for young children.
2. Drinking of alcoholic beverages before or during spa or hot tub use can cause drowsiness which could lead to unconsciousness and subsequently result in drowning.
3. **Pregnant Women Beware!** Soaking in water over 102° F (39°C) can cause fetal damage during the first three months of pregnancy, (resulting in the birth of a brain damaged or deformed child). Pregnant women should stick to the 100°F (38°C) maximum rule.
4. Before entering the spa or hot tub, users should check the water temperature with an accurate thermometer; spa or hot tub, thermostats may err in regulating water temperatures by as much as 4°F (2.2°C).
5. Persons with a medical history of heart disease, circulatory problems, diabetes, or blood pressure problems should obtain a physician's advice before using pools or hot tubs.
6. Persons taking medications which induce drowsiness, such as tranquilizers, antihistamines, or anticoagulants, should not use spas or hot tubs.

SECTION 3 / MAINTENANCE AND CARE PROCEDURES

To be followed one month after start-up and then semi-annually.

1. Inspect top of heater and draft hood for soot, (a sticky black substance around finned tubes and "V" baffles), and open flue gas passageways.

CAUTION: *Soot may be combustible. Wet sooted surfaces completely prior to cleaning. Do not use steel wire brush.*

2. Clean main burners and pilot burner of dust and lint.
3. Inspect and operate all controls, gas valve and pressure relief valve.
4. Make a visual check of the burner and pilot flame. Flame pattern on the main burner and pilot is indicated in the previous illustration. Yellow flame means restriction of the air openings. Lifting or blowing flame indicates high gas pressure. Low flame means low gas pressure. Should this occur, shut the heater off and contact your gas supplier or qualified service agency.
5. On indoor heaters, clean room intake openings to assure adequate flow of combustion and ventilation air.

CAUTION: *Combustion air must not be contaminated by corrosive chemical fumes which can damage the heater and void the warranty.*

6. Keep area around heater clear and free from combustible materials, gasoline and other flammable and corrosive vapors and liquids.

BASIC TIPS IF HEATER WILL NOT FIRE:

1. If you have no electrical power; it may be your "circuit breakers" have tripped. Try re-setting them.
2. If you have electrical power but the heater will not fire

check the following:

3. The time clock must be moved to the "ON" position.

4. Your pump strainer basket may be full. If so remove debris.
5. Your filter may be dirty. If so, backwash or clean filter. (To tell if your filter is dirty, the gauge pressure will be higher than usual).
6. The pump may have lost it's prime. It may be running dry, check the pressure gauge on the filter. If there is no pressure; then you are not moving water (or your gauge is broken). Try to get the pump to run at it's normal flow rate.

POOL & SPA WATER CHEMISTRY

Chemical imbalance can cause severe damage to your heater and associated equipment. Maintain your water pH between 7.4 and 7.8 and total alkalinity between 100 and 150 p.p.m. If the mineral content and dissolved solids in the water become too high, scale forms inside the heat exchanger tubes, reducing heater efficiency and also damaging the heater. If the pH drops below 7.2, the heater will be severely damaged. This will result in corrosion of the heat exchanger. **Heat exchanger damage resulting from chemical imbalance is not covered by the warranty.**

AUTOMATIC CHLORINATORS AND CHEMICAL FEEDERS

All chemicals must be introduced and completely diluted into the pool or spa water before being circulated through the heater. Do not place chlorine tablets or bromine sticks in the skimmer. High chemical concentrations will result when the pump is not running (i.e. overnight).

Chlorinators must feed downstream of the heater and have an anti-siphoning device to prevent chemical back-up into the heater when the pump is shut off.

NOTE: *High chemical concentrates from feeders and chlorinators that are out of adjustment will cause very rapid corrosion to the heat exchanger in the heaters. Such damage is not covered under the warranty.*

COLD WEATHER OPERATION

MODERATE CLIMATE: Heater operation can continue during short term cold spells. When temperatures are below freezing flow, (continuous pump operation) must be maintained.

CAUTION: Do not use the heater to maintain water temperatures just above freezing or for freeze protection. When heaters are used during freezing weather, care must be taken to avoid freeze ups. Continuous pump operation is a must. Additional protection may be required. The heater is not warranted against freeze ups.

COLD CLIMATE: Prolonged operation with water temperatures below 50°F is not recommended. When starting the heater with pool temperatures below 50°F, operate the heater continuously until higher temperatures are reached. Operating the heater for prolonged periods with pool water below 50° can seriously damage the heater, and is not covered by the warranty. For cold climate areas please follow the winterizing procedures listed .

3. Disconnect compression fittings from the pressure switch and return header that connects to the 1/4" copper tube and allow the tube to drain.

WINTERIZING THE POOL & SPA HEATER

When heaters installed outdoors in freezing climate areas are to be shut down for the winter, observe the following step-by-step procedure:

1. Turn off gas valve, manual gas valve, and electrical supply to the heater.
2. Open drain cock located on the inlet/outlet header, (under water pipes). Tilt heater to completely drain all the water from the heat exchanger.

PRESSURE SWITCH
COMPRESSION FITTING

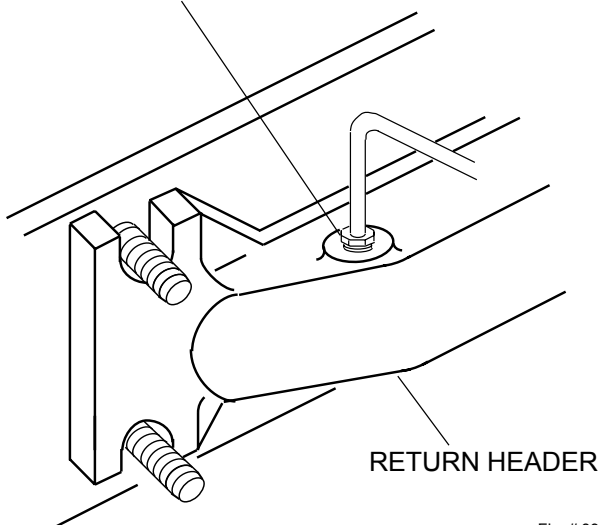

Fig. # 8955

PART 2 - INSTALLATION / SERVICE INSTRUCTIONS

SECTION 1 / RECEIVING EQUIPMENT

On receipt of your equipment it is suggested that you visually check for external damage to the carton. If the carton is damaged, a note should be made on the Bill of Lading when signing for equipment. Remove the heater from the carton and if it is damaged, report the damage to the carrier immediately.

On occasion, we ship some items loose. Be sure that you receive the number of packages indicated on the Bill of Lading.

When ordering parts, you must specify model and serial number of the heater. When ordering under warranty conditions, you must also specify date of installation.

Raypak recommends that this manual be reviewed thoroughly before installing your Raypak pool/spa heater. If there are any questions that this manual does not answer, please contact the factory or your local Raypak Representative.

SECTION 2 / GENERAL SPECIFICATIONS

These heaters are design certified and tested under the requirements of ANSI Z21.56/CSA 4.7 American National Standard/CSA Standard for gas fired pool heaters.

The heater is interchangeable and can be used either indoor or outdoors. The appropriate top designated for that type of use is required. If desired, the top can be changed at a later date to change from outdoor to indoor or vice versa. Millivolt heaters contain a self-generating electrical system operating between .25 and .75 volts.

AMBIENT TEMPERATURE RATING OF HEATER COMPONENTS

Millivolt Heater with Honeywell Gas Valve
+32°F to +175°F

Millivolt Heater with Robertshaw Gas Valve
0°F to +175°F

Electronic Ignition Heater *
-32°F to + 175°F

* Requires 120V or 240V Power Supply

Rated inputs suitable for up to 2000 feet elevation. For elevations above 2000 feet, reduce input 4% for each 1000 feet above sea level, as high elevation reduces combustion performance.

SECTION 3 / INSTALLATION INSTRUCTIONS

IMPORTANT NOTICE

These instructions are intended for the use of qualified personnel only, specifically trained and experienced in the installation of this type of heating equipment and related system components. Installation and service personnel may be required by some states to be licensed. If your state is such, be sure your contractor bears the appropriate license. Persons not qualified shall not attempt to fix this equipment nor attempt repairs according to these instructions.

WARNING: *Improper installation, adjustment, alteration, service or maintenance may damage the equipment, create a hazard resulting in asphyxiation, explosion or fire, and will void the warranty.*

CODE REQUIREMENTS

NOTE: *The heater should not be located in an area where possible water leakage will result in damage to the area adjacent to the appliance or to the structure. When such locations cannot be avoided, it is recommended that a suitable drain pan, adequately drained, be installed under the appliance. The pan must not restrict combustion air flow.*

Installation must be in accordance with local codes, or, in the absence of local codes, with the latest edition of the National Fuel Gas Code, ANSI Z223.1, and the National Electrical Code, ANSI/NFPA 70.

BASE INSTALLATION

Heater must be mounted on a level base, such as cement slab, cement blocks or another non-combustible surface. An optional non-combustible base is available for all models. An alternate method for providing a base for combustible floors is illustrated. Heaters may not be installed on carpeting.

ALTERNATE METHOD FOR PROVIDING A NON-COMBUSTIBLE BASE

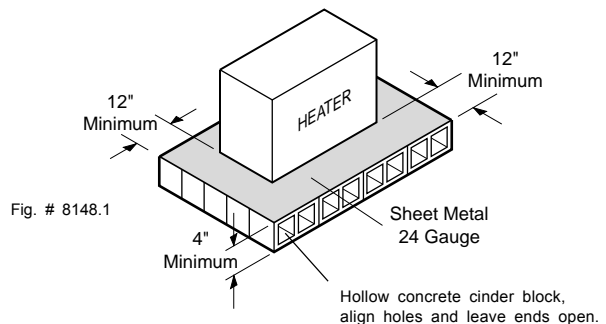

CLEARANCES

WARNING: The heater shall not be located in an area where water sprinklers, or other devices, may cause water to spray through the cabinet louvers and into the heater. This could cause heavy internal rusting or damage some electrical components, and this would void the warranty.

ALL HEATERS

For clearances from combustable surfaces, see the following chart.

CLEARANCES FROM COMBUSTIBLE CONSTRUCTION		
INDOOR INSTALLATION		OUTDOOR INSTALLATION
Top*(Drafthood) - 42"	Right Side - 6"	Top *(Stackless Top or Outdoor Stack) - Unobstructed
Vent - 6"	Left Side - 12"	Back - 12"
Back-12"	Front - Alcove	Sides - 6"

*Clearance from Top of Vent Terminal.

For servicing, provide at least 24" in front of the heater for burner tray removal, and at least 18" on the back of the heater to inspect and delime the heat exchanger.

OUTDOOR HEATERS

These heaters are design certified for outdoor installation, when equipped with the approved tops designated for outdoor use.

HEATER WITH OUTDOOR
STACKLESS TOP

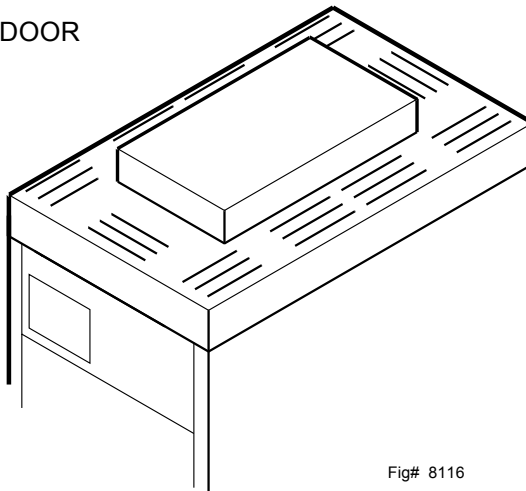

Fig# 8116

WARNING: Do not install within 3 feet of a Heat Pump or an outdoor condensing unit. Strong air intake from this equipment can disturb the combustion process and cause damage or personal injury.

Heaters must not be installed under an overhang of less than three (3) feet from the top of heater. Three (3) sides must be open in the area under the overhang. Roof water drainage must be diverted away from the heaters installed under overhangs with the use of gutters:

The point from where the flue products exit the heater must be a minimum of four (4) feet below, four (4) feet horizontally from or one (1) foot above any door, window or gravity inlet to a building. The top surface of the heater shall be at least three (3) feet above any forced air inlet, or intake ducts located within ten (10) feet horizontally.

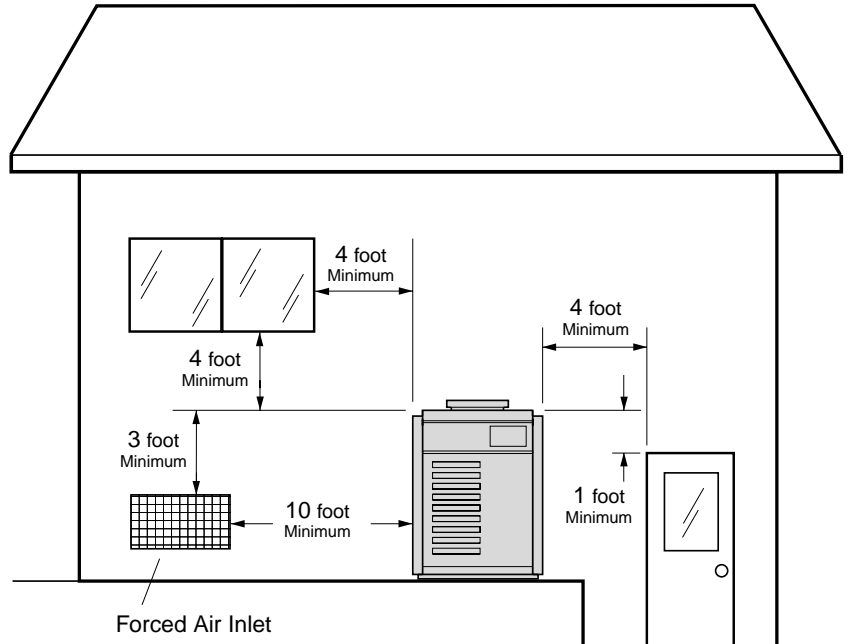

Fig. # 8245.1

HIGH WIND CONDITIONS (OUTDOOR UNITS ONLY)

In areas where high winds are frequent, it may be necessary to locate the heater a minimum of 3' from high vertical walls, or install a wind break so the heater is not in direct wind current.

In areas of daily high winds, it may be necessary to replace the outdoor stackless top with a stack adapter in combination with a wind resistant/weather proof outdoor stack. See illustration below.

The outdoor stack serves the same function as the low profile stackless top and should be installed in accordance with the same clearance requirements.

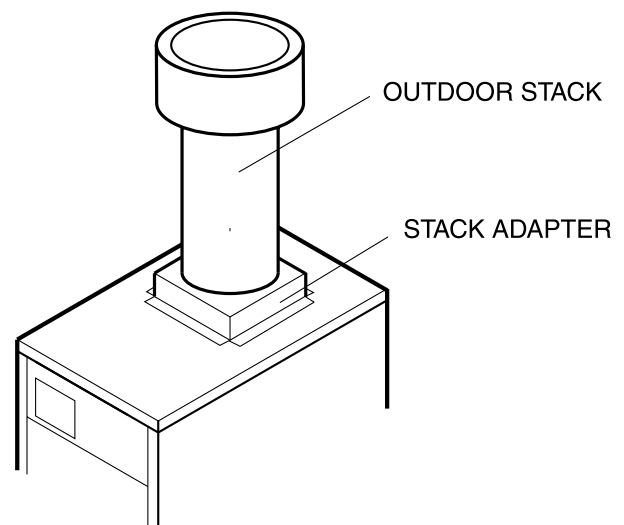

Fig. # 9304

INDOOR HEATERS

The design is also certified for indoor installation when equipped with the approved draft hood. Locate heater as close as practical to a chimney or gas vent. Heater must always be vented to the outside. See Vent Piping Section for venting details. Minimum allowable space is shown on the nameplate.

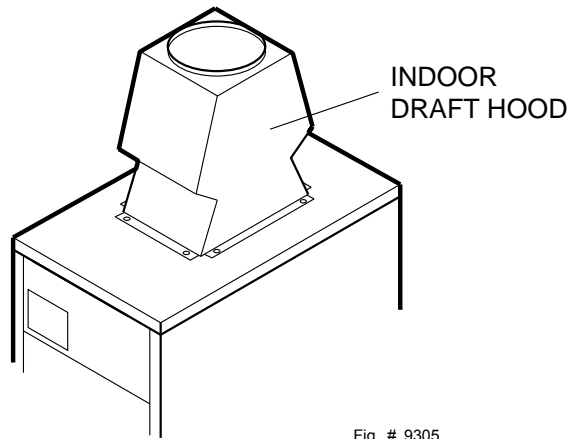

Fig. # 9305

COMBUSTION AIR (INDOOR UNITS ONLY)

AIR FOR COMBUSTION AND VENTILATION (Indoor Units Only)

The heater must have both combustion and ventilation air. Minimum requirements for net free air supply openings, one 12 inches from ceiling for ventilation and one 12 inches from the floor for combustion air as outlined in Z 223.1 - 1988 and any local codes that may have jurisdiction.

CAUTION: *Combustion air must not be contaminated by corrosive chemical fumes which can damage the heater and void the warranty.*

- a. All Air From Inside the Building:
Each opening shall have a minimum of 151 net free square inches.
- b. All Air From Outdoors:
When air is supplied directly from outside of building, each opening shall have a minimum of 38 net free square inches.

VENTING CONNECTIONS

VENT TERMINAL (Outdoor) STACKLESS TOP

STEP 1 : Remove the front (4) screws which fasten jacket top to heater.

STEP 2 : Line up top vent opening over heater vent opening.

STEP 3 : Lower outdoor top onto unit lining up slots in outdoor top with screw holes in jacket top.

STEP 4 : Reinstall (6) screws to secure jacket top and outdoor top to unit.

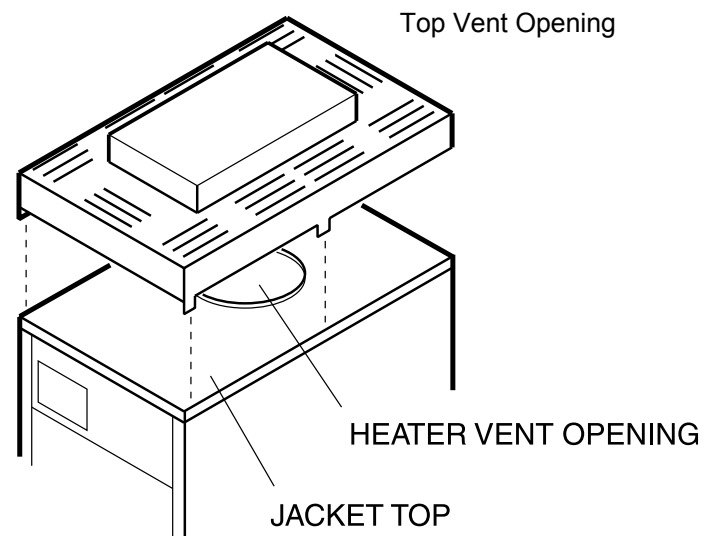

Fig. # 9306

VENT TERMINAL (Outdoor) OUTDOOR STACK

- STEP 1** Line up (8) holes in jacket top with (8) holes in adapter assembly.
- STEP 2** Lower entire outdoor stack assembly on to jacket top.
- STEP 3** Secure with fasteners provided.

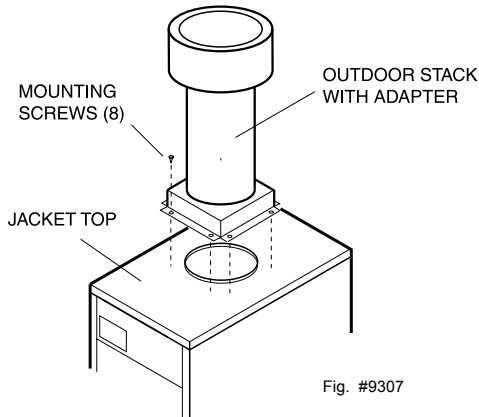

Fig. #9307

VENT TERMINAL (Indoor)

Locate and assemble as shown. Secure with screws supplied in envelope inside carton.

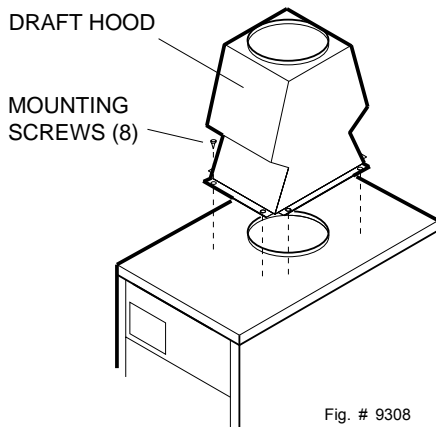

Fig. # 9308

VENT PIPING

WARNING: Indoor boilers require a draft hood that must be connected to a vent pipe and properly vented to the outside. Failure to follow this procedure can cause fire or fatal carbon monoxide poisoning.

Vent piping the same size or larger than the draft hood outlet is recommended, however, when the total vent height is at least ten (10) feet (draft hood relief opening to vent terminal), the vent pipe size may be reduced as specified in Chapter 10 of the latest edition National Fuel Gas Code, **ANSI Z 223.1**. As much as possible avoid long

horizontal runs of vent pipe and too many elbows. If installation requires horizontal non-vertical runs, the vent pipe must have a minimum of 1/4 inch per foot rise and should be supported at not less than five foot intervals. Plumbers tape, criss-crossed, will serve to space both horizontal and vertical piping. Gas vents supported only by the flashing and extending above the roof more than five feet should be securely guyed or braced to withstand snow and wind loads. We recommend use of insulated vent pipe spacer through the roofs and walls.

For protection against rain or blockage by snow, the vent pipe must terminate with a vent cap which complies with the local codes or, in the absence of such codes, latest edition of the National Fuel Gas Code, **ANSI Z 223.1**.

The discharge opening must be a minimum of two feet vertically from the roof surface and at least two feet higher than any part of the building within ten feet. Vent stack shall be at least five feet in vertical height above the draft hood outlet. The vent cap location shall have a minimum clearance of 4 feet horizontally from, and in no case above or below, unless a four foot horizontal distance is maintained, from electric meters, gas meters regulators and relief equipment.

The weight of the vent stack or chimney must not rest on boiler draft hood. Support must be provided in compliance with applicable codes. The boiler top and draft hood must be readily removeable for maintenance and inspection. Vent pipe should be adequately supported to maintain proper clearances from combustible construction.

Type "B" double wall or equivalent vent pipe is recommended. However single wall metal vent pipe may be used as specified in the latest edition of the National Flue Gas Code **ANSI Z 223.1**.

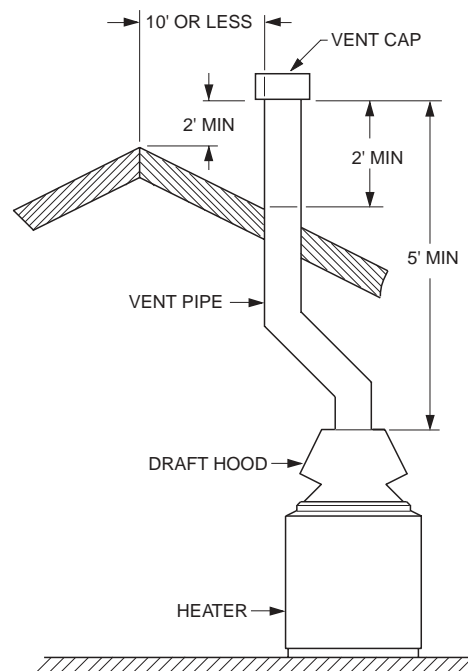

Fig. # 8119.0

GAS SUPPLY CONNECTIONS

Gas piping must have a sediment trap ahead of the heater gas controls, and a manual shut-off valve located outside the heater jacket. All gas piping should be tested after installation in accordance with local codes.

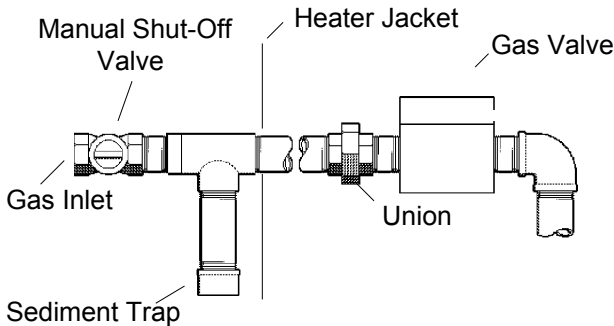

Fig. # 8090.0

CAUTION: The heater and its manual shut off valve must be disconnected from the gas supply during any pressure testing of that system at test pressures in excess of 1/2 psig (3.45 KPA). Dissipate test pressure in the gas supply line before reconnecting the heater and its manual shut off valve to gas supply line. FAILURE TO FOLLOW THIS PROCEDURE MAY DAMAGE THE GAS VALVE. OVER PRESSURED GAS VALVES ARE NOT COVERED BY WARRANTY. The heater and its gas connections shall be leak tested before placing the appliance in operation. Use soapy water for leak test. Do NOT use open flame.

NOTE: Do not use teflon tape on gas line pipe thread. A flexible sealant is recommended.

A minimum of 7" W.C. and a maximum of 14" W.C. upstream pressure under load, and no load conditions must be provided for natural gas or a minimum of 12" W.C. and a maximum of 14" for propane gas.

GAS PRESSURE REGULATOR

The gas pressure regulator is present and sealed at 4"W.C. for natural gas, and 11"W.C. for propane gas. Between the gas valve and the burners is a 1/8" pipe plug. The pressure at this point, taken with a manometer, should be about 3.7"W.C. natural gas and 10.5"W.C. propane gas. If an adjustment is needed, remove seal and turn adjustment screw clockwise

to increase pressure or counter-clockwise to decrease pressure.

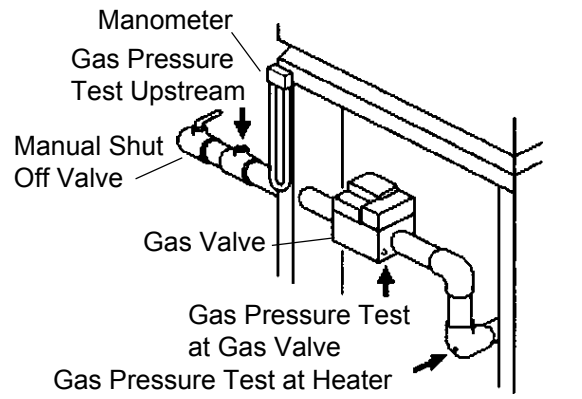
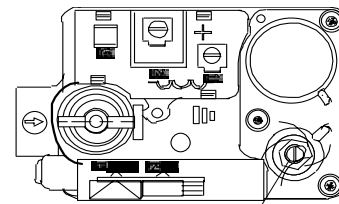

Fig. # 8149.0

ROBERTSHAW VALVE



W. C. adjustment

HONEYWELL VALVE

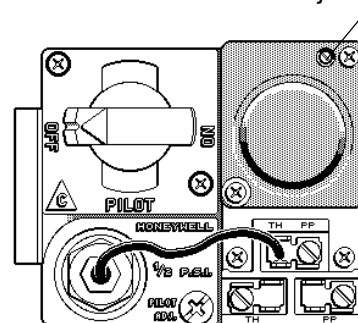

W. C. adjustment

Fig. # 8081.0

PIPE SIZING FOR GAS CONNECTIONS

MAXIMUM EQUIVALENT PIPE LENGTH

Natural Gas 1000BTU/FT ³ .60 Specific Gravity @ 0.5" WC Pressure Drop						
Propane Gas 2500BTU/FT ³ 1.53 Specific Gravity @ 0.5" WC Pressure Drop						
MODEL	1/2"		3/4"		1"	
	N	P	N	P	N	P
155B	15	35	60	145	200	500

PLUMBING FOR WATER CONNECTIONS

LOCATION

The VERSA heater requires water flow and positive pressure to fire and operate properly. It must therefore be installed downstream of the discharge side of the filter pump. A typical installation is plumbed as follows:

1. The inlet side of the filter is plumbed directly to the discharge side of the filter pump;
2. The outlet side of the filter is then plumbed to the inlet of the heater; and
3. The outlet of the heater is plumbed to the return line to the pool or spa. The pump, filter and heater are thus plumbed in series.

Plumbing from the heater back to the pool must not have any valves or restriction that could prevent flow when the pump is operating. To do so will void the warranty

Heater must be located so that any water leaks will not damage the structure of adjacent area. High temperature 2" plastic pipe (CPVC) may be threaded directly into the header flanges. This is not the same as the Schedule 80 PVC pipe which is also colored gray. PVC may be used immediately after the CPVC adapters

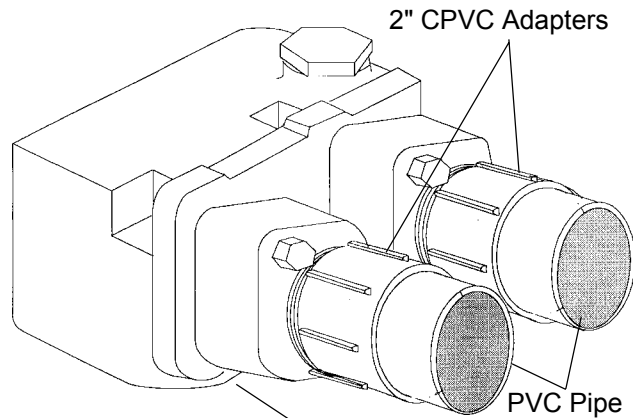

Fig. # 8192.1

INLET/OUTLET HEADER

CAUTION: NEVER install PVC directly into header flanges. Use the 2" CPVC adapter supplied loose with the heater.

FLOW RATES

MIN GPM 20

MAX GPM 115*

*When flow rates exceed 115 GPM an external auxiliary bypass valve is required. See external auxiliary bypass valve section for details.

COMPANION FLANGE CONNECTIONS

DO NOT use petroleum base assembly fluids (such as Petroleum Jelly or lubricating oil). If assembly lubrication is required use a silicone base such as Amoral etc.

The inlet/outlet single header flanges are designed for four type of water connections. There are two sets of flange gaskets supplied with your header; one set installed, between flanges and in/out header, and the other set shipped loose in the unit. Use the appropriate gasket design, for all your heater connections.

GASKET DESIGN #1: (Factory installed) Accepts 1-1/2" copper tube or 1-1/4" galvanized pipe as a slip connections.

GASKET DESIGN #2: (Loose In a bag) Accepts 2" copper tube as a slip connection. The flange is threaded for 2" screw in pipe connections. Also used with the 2" CPVC adapters.

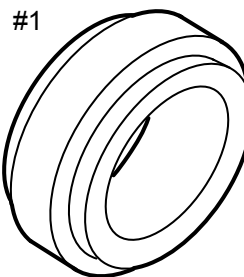

Fig. # 8095.1

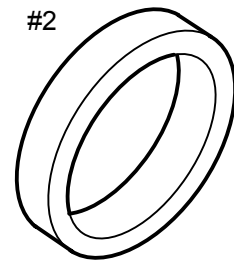

Fig. # 8097.1

INLET/OUTLET HEADER

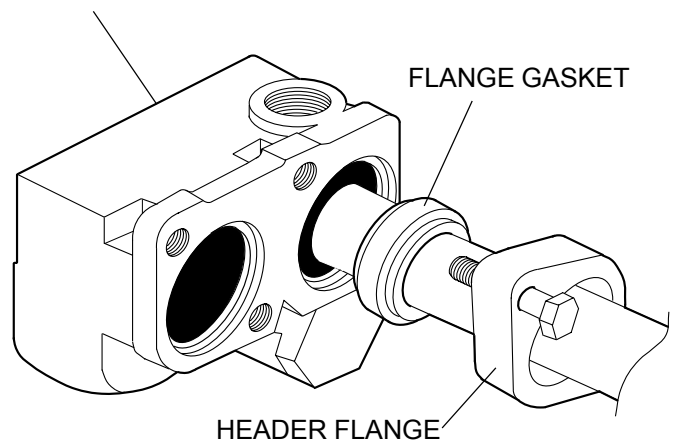

Fig. # 8093.1

UNITHERM GOVERNOR OPERATION

The patented Unitherm Governor is a thermostatic mixing valve specifically designed to maintain constant heater internal temperature between 105°-115°F despite continually changing flow rates from the filter and changing pool temperatures. This narrow range is needed to prevent damaging condensation on the burners which will occur if the heater runs for any length of time below 100°F. It is also needed to inhibit scale formation in the tubes by maintaining temperatures well below accelerated scaling temperatures.

INTERNAL AUTOMATIC BY-PASS VALVE

In addition to the Unitherm Governor, a built-in automatic by-pass valve is provided in the in/out header. While the Unitherm Governor responds to the changes in water temperature in the heater, the internal by-pass valve automatically responds to changes in water pressure in the piping system. Proper amount of water flow is maintained through the heater under varying pressures dictated by the conditions of the pump and filter.

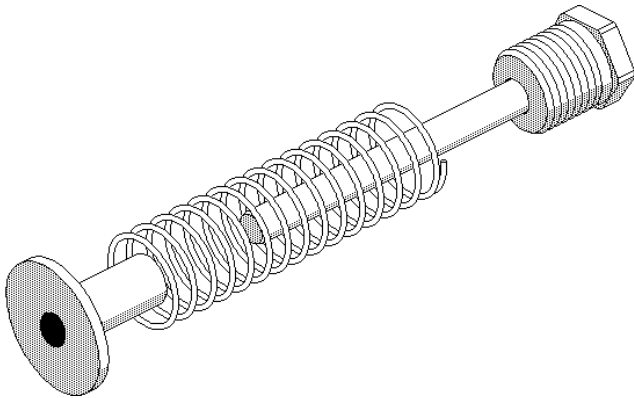

Fig. # 8078.0

EXTERNAL AUXILIARY BYPASS VALVE (where required)

An auxiliary bypass valve should be used when flow rates exceed 115 GPM (usually a high performance pump size larger than 2 HP will exceed this flow rate). This valve is required to complement the function of the automatic bypass valve, particularly when starting the heater in winter or early spring when the spa or pool temperature is down below 50°F. It also serves to eliminate needless pressure drop through the heater and accompanying reduction in the flow rate to the spa jets, etcetera.

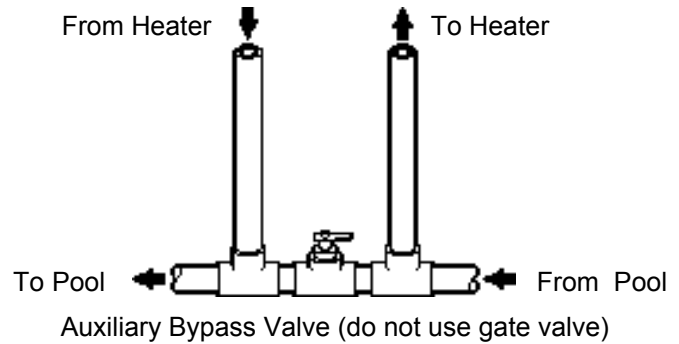

Fig. # 8150.0

AUXILIARY BYPASS VALVE ADJUSTMENT

To set bypass: With clean filter, adjustment is made by feeling the inlet and outlet pipes at the heater. Outlet pipes should be slightly warmer than inlet and comfortable to the touch. If pipe is hot, close bypass; if cold, open bypass.

PRESSURE RELIEF VALVE INSTALLATION

To conform to local building codes, it may be necessary to install a pressure relief valve. A 3/4" pressure relief valve having a capacity equal to BTU/HR output of the heater to be installed is recommended for this appliance.

A 3/4" NPT connection is provided in the inlet/outlet header for installation of a pressure relief valve. The valve shall be installed in a vertical position.

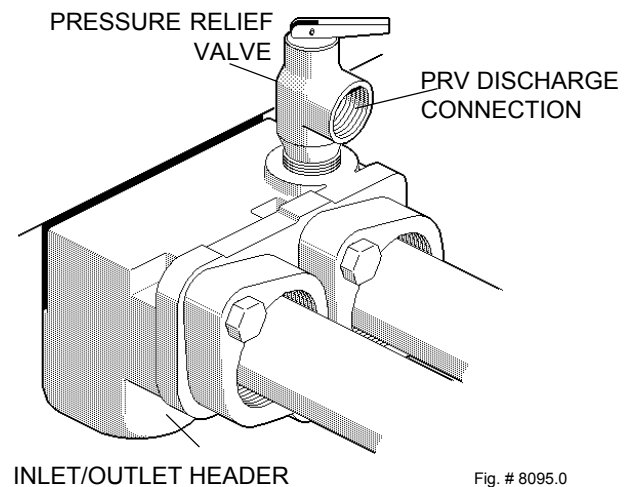

Fig. # 8095.0

NOTE: To avoid water damage or scalding due to valve operation, drain pipe must be connected to valve outlet and run to a safe place of discharge. Drain pipe must be the same size as the valve discharge connection throughout its entire length and must pitch downward from the valve. No shut-off valve shall be installed between the relief valve and the drain line. Valve lever should be tripped at least once a year to ensure that waterways are clear.

ELECTRICAL WIRING

NOTE: If it is necessary to replace any of the original wiring, it must be replaced with 105°C wire or its equivalent, except all black wire must be replaced with 150°C wire or its equivalent.

CAUTION: Label all wires prior to disconnection when servicing controls. Wiring errors can cause improper and dangerous operation. Verify proper operation after servicing.

DANGER - SHOCK HAZARD - Make sure electrical power to the heater is disconnected to avoid potential serious injury or damage to components.

MILLIVOLT SYSTEM

The *Millivolt System Residential Heater* is equipped with a self-generating electrical system in which the electric current is provided by means of a pilot generator. No external electrical connections are required.

ELECTRONIC INTERMITTENT IGNITION DEVICE SYSTEM (IID)

NOTE: When the electrical hookup to the heater requires both 24V and 115V or 240V, each input voltage must be isolated in separate conduit.

The *Electronic Intermittent Ignition Device* automatically lights the pilot and main burners upon a call for heat. The heater is supplied with a dual voltage transformer for 120V or 240V input power hookup. Heaters are factory wired for 240V power supply.

NOTE: IID PROPANE UNITS ONLY: Heater is equipped with an electronic ignition device with a 100% safety lockout feature. If the heater fails to start or lockout, reset the ignition device by interrupting the power to the heater for 60 seconds.

CAUTION: If service replacement of the electronic ignition device is required, replace only with a 100% safety lockout device with 90 second trial for pilot ignition.

HONEYWELL INTERMITTENT IGNITION DEVICE

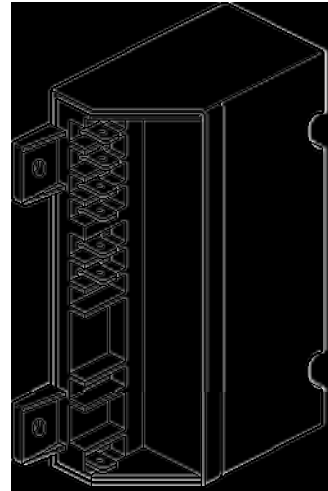

Fig. # 8929.1

For 120 V input power to the unit, connect the black wire to the "L1" or hot leg of the power supply. Connect the white wire to the "L2" or neutral leg of the power supply. Attach the wire nut to the red wire. There should be no connection to the red wire for 120V operation.

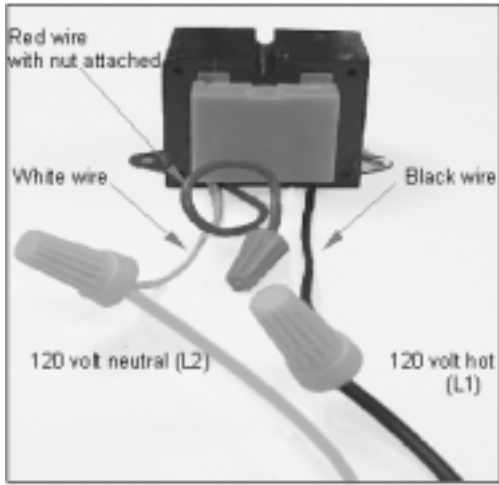

Fig. #9240

For 240 V input power to the unit, connect the black wire to the "L1" or hot leg of the power supply. Connect the red wire to the "L2" or second hot leg of the power supply. Attach the wire nut to the white wire. There should be no connection to the white wire for 240V operation.

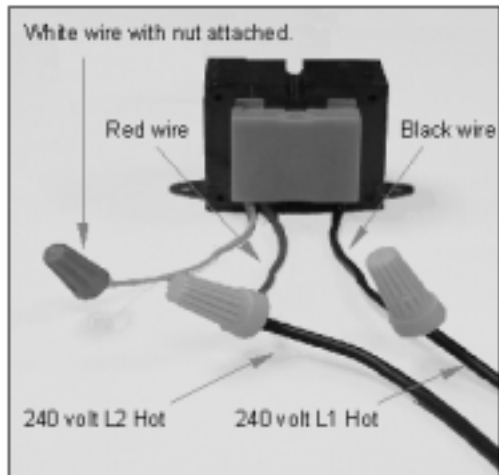
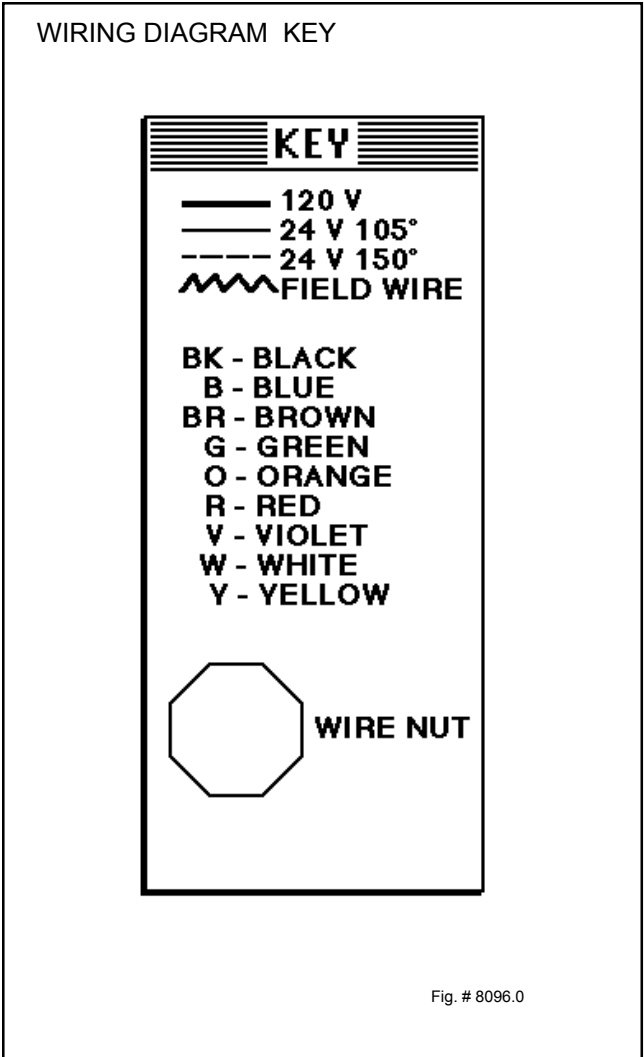

Fig. # 9241

Heater must be electrically grounded and bonded in accordance with local codes, or, in the absence of local codes, with the latest edition of the National Electrical code, **ANSI/NFPA 70.**

NOTE: Input power to the heater (120/240V) should be supplied from the load (Pump) side of time clock or switch. Connecting heater to continuous power source will allow "Fail" indications (service and pressure switch) when pump is not operating.



WIRING DIAGRAM MILLIVOLT UNITS

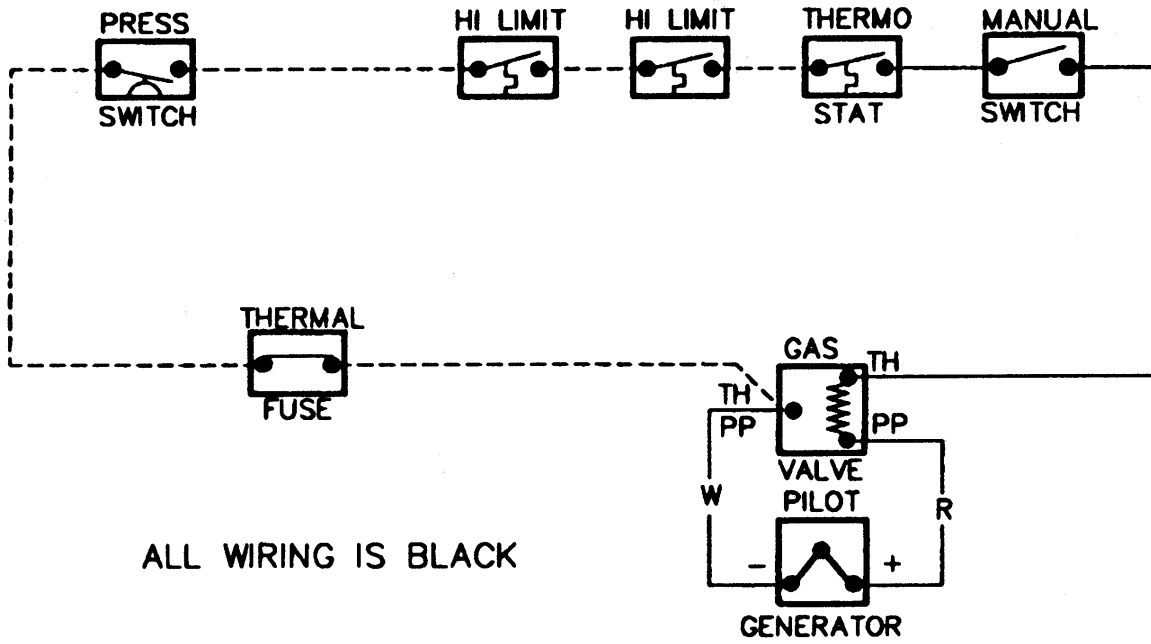

ALL WIRING IS BLACK

Fig. #2182e

WIRING DIAGRAM 152148 Model 155 IID

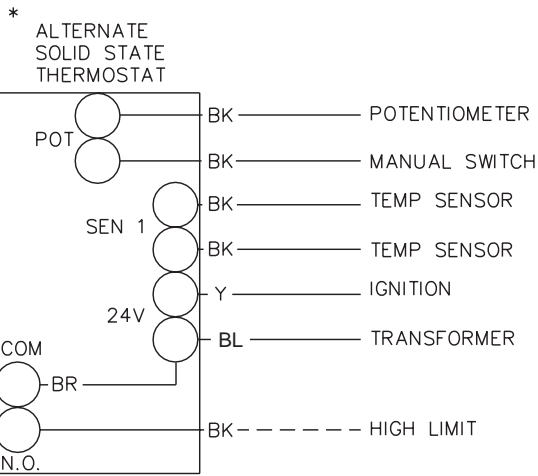
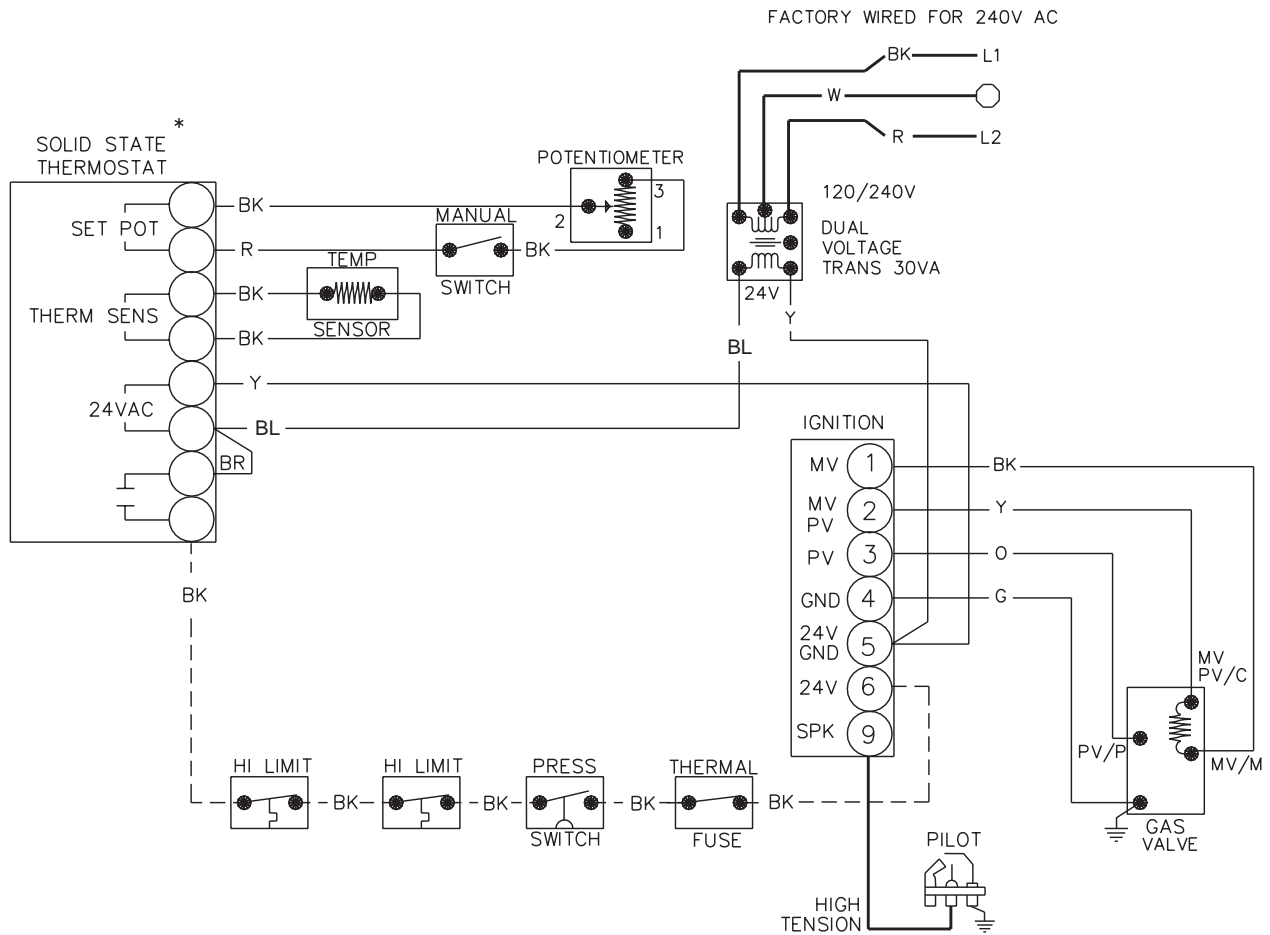

SECTION 4 / SERVICING INSTRUCTIONS

GENERAL LOCATION OF CONTROLS

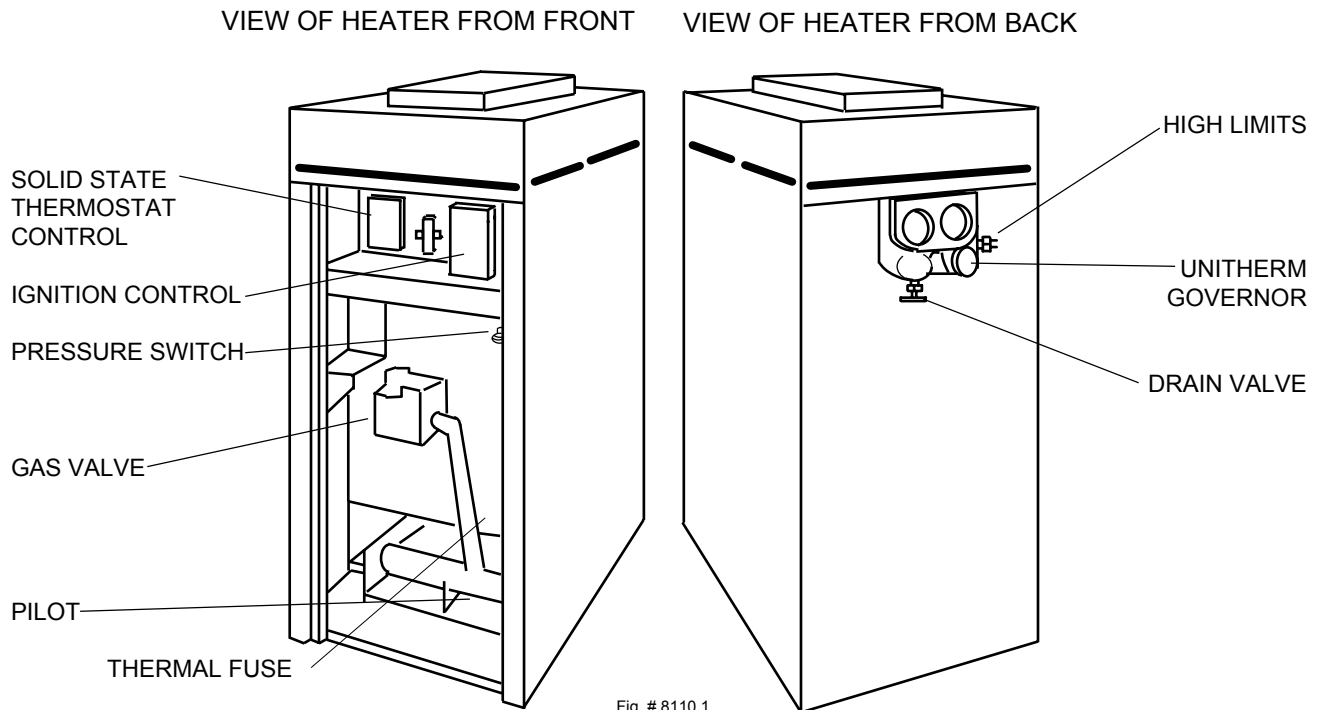

CONTROL PANEL REMOVAL

1. Remove lower door.
2. Remove (2) screws from bottom flange of control panel.
3. Slide down control panel to clear jacket top panel.
4. Rotate control panel down until panel stops. Do not force.

NOTE: Caution must be taken not to damage controls or wiring.

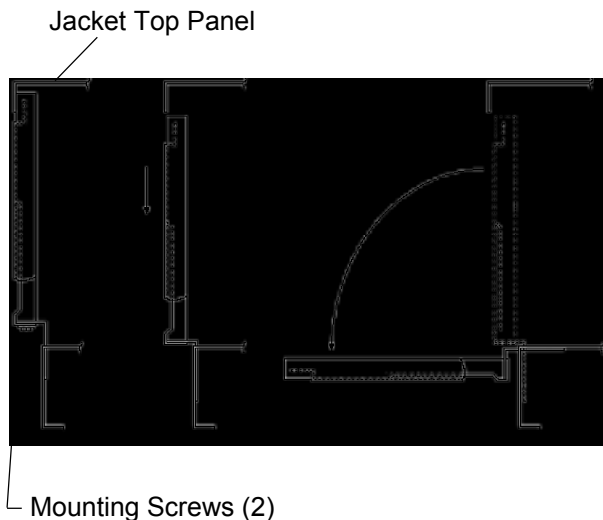

CONTROLS / ADJUSTMENTS / REPLACEMENTS

TEMPERATURE CONTROLS

The pool or spa water temperature is controlled by the pool heater thermostat on the upper front panel of the heater. The control center contains an On/Off toggle switch and a thermostat. The switch functions as a means for turning the heater on or off.

The thermostat is fitted with a means of limiting the upper temperature limit below the maximum level. The knob stop adjustment ring illustrated below is adjustable by loosening the set screw, rotating the knob stop ring to the desired location and retightening the set screw.

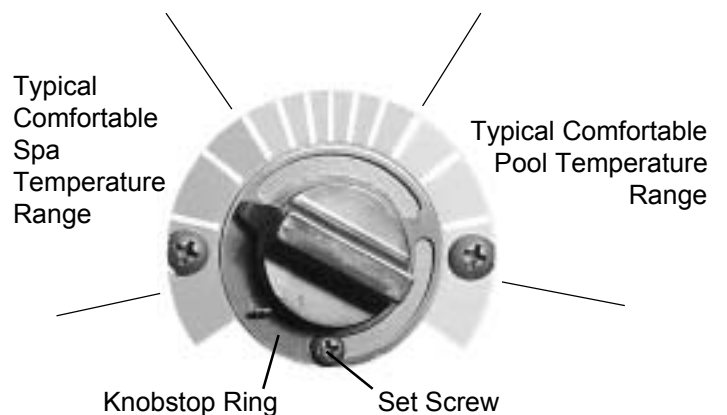

PRESSURE SWITCH

The pressure switch, or heater actuator, insures that the heater operates only when the filter pump is in operation. It is factory set at 1.75 PSI for deck level installations. When the heater is located below the level of the spa or pool, it may be necessary to reset the pressure switch to compensate for the no-flow static head. If it is necessary to reset the pressure switch, we recommend the following procedure:

PRESSURE SWITCH ADJUSTMENT:

1. With pump and heater on, turn adjustment knob (clockwise) until a click is heard from the gas valve.
2. Turn adjustment knob (counter clockwise) 1/4" turn.
3. Turn pump off and on several times. Heater should shut off immediately. If it does not, repeat steps above until proper adjustment is made.

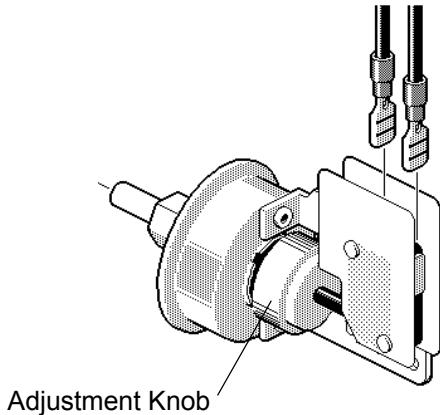

Fig. # 8069.1

PRESSURE SWITCH ADJUSTMENT RANGE

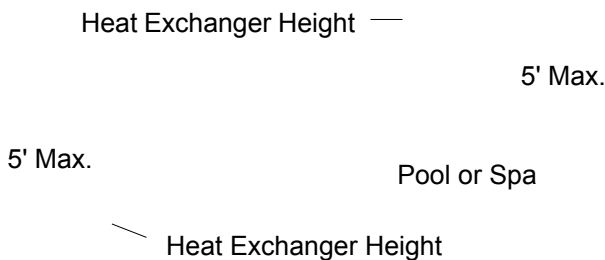

Fig. # 8152.0

NOTE: If heater is installed outside of the limits shown, a flow switch must be used in place of the pressure switch when mounted and wired adjacent to the heater.

TWO SPEED PUMPS

In some cases, the flow on the low-speed is insufficient to operate the heater. This is apparent when the pressure switch cannot be further adjusted or if the heater makes banging noises. In these cases, the pump must be run at high speed when heating the water.

CAUTION: Do not operate the heater without the function of a properly adjusted pressure switch.

HIGH LIMITS

The heater is equipped with two automatic high limits. Set to operate at 135°F and 140°F.

NOTE: An erratic high limit is often characteristic of an internal heat exchanger problem, i.e. scale buildup, and U.G. operation. Refer to troubleshooting section.



Fig. # 8153.0

HIGH LIMIT REMOVAL

1. Shut off main electrical power switch to heater.
2. Remove inspection panels.
3. Drain heater.
4. Remove defective high limit and replace with a new high limit.
5. Reverse above procedure to re-install.

FLAME ROLL-OUT SAFETY SWITCH

The heater is equipped with a thermal cutoff device to prevent flame roll-out in the event the heat exchanger becomes blocked. This is a "Single-use" type fusible link or thermal fuse, that must be replaced when disabled by an over temperature condition, caused by excessive restriction in the heat exchanger flue passage.

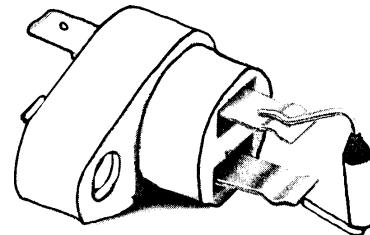

Fig. #9177

PILOT SAFETY (Millivolt System)

The heaters equipped with the standing pilot (millivolt system), have pilot generators which act as a safety device to shut off the flow of gas to the main burners and the pilot burner in case the pilot flame is extinguished. The pilot burner must be manually re-lighted to place the heater in operation again. Refer to the lighting instructions provided on the heater label.

PILOT SAFETY (IID Units) ELECTRIC IGNITION

The heater employs a pilot safety which closes the main gas valve within 8/10ths of a second whenever the pilot flame is interrupted. Pilot flame is automatically lit when the device is powered. Unit performs its own safety check and opens the main valve only after the pilot is proven to be lit.

BURNER DRAWER REMOVAL

1. Shut off main electrical power switch to heater.
2. Shut off gas upstream of heater.
3. Remove front door.
4. Disconnect gas line from gas valve.
5. Remove (2) screws that mount burner tray to unit, and (2) screws that secure gas valve to jacket.
6. Disconnect wires that terminate at gas valve.
7. Slide out burner tray.
8. Reverse above procedure to reinstall.

GAS VALVE REMOVAL

1. Shut off gas supply to the heater. Remove gas piping to gas valve inlet.
2. Disconnect wires, pilot tubing and bleed line, if required.
3. Turn vertical gas pipe from manifold slightly and unscrew gas valve.
4. Reverse above procedure to re-install.

MAIN BURNER AND ORIFICE REMOVAL

1. Remove burner drawer. See burner drawer removal procedure.
2. Remove screws and burner hold down bracket.

NOTE: If the heat exchanger is sooted badly, the burner hold down bracket and spacer can become distorted from direct flame impingement and this usually necessitates replacement of these parts.

3. Lift burners from slotted spacers and slide from orifices. Clean with a wire brush.
4. Orifices usually do not need to be replaced. To clean, run either copper wire or wood toothpick through orifice. Do not enlarge hole. To remove orifice, use a socket wrench and remove from manifold. **DO NOT** overtighten when reinstalling.

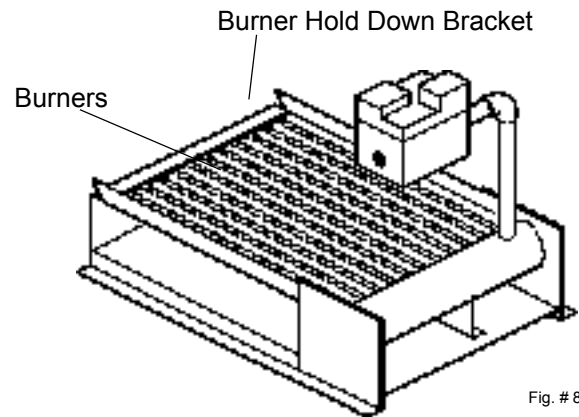
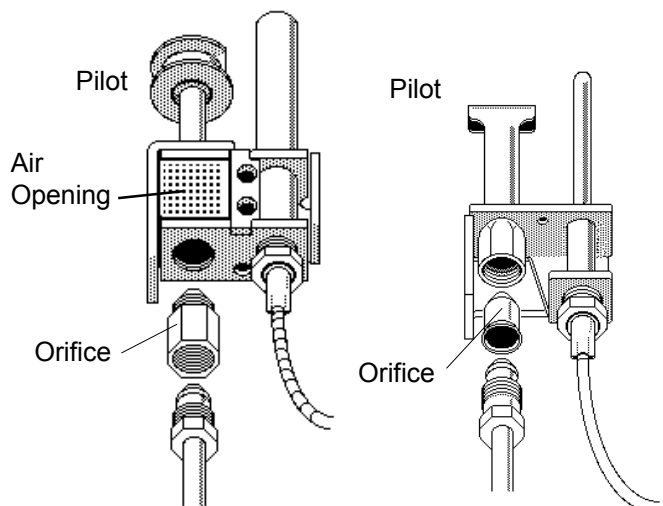

Fig. # 8057.0

PILOT REMOVAL AND CLEANING

1. Disconnect pilot tubing, and wires from gas valve.
2. Remove pilot assembly from burner tray.
3. Remove pilot from bracket.
4. Remove pilot orifice and air opening (Honeywell MV unit only), and clean with wire or small brush. **CAUTION!** Do not enlarge hole in pilot orifice.
5. Reverse above procedure to reinstall.



HONEYWELL PILOT

Fig. # 8045.1

ROBERTSHAW PILOT

Fig. # 8102.0

HEAT EXCHANGER REMOVAL

1. Shut water, gas and electricity off, close valves and relieve pressure, remove relief valve. Remove side inspection panels.
2. Remove top holding screws.
3. Remove draft diverter, lift and remove top and flue collector on stack-type models. Remove inspection panels.
4. Loosen bolts and disconnect flange nuts on inlet/outlet header, loosen union(s) at gas pipe and slide boiler away from piping until studs clear the header.
5. Remove combustion chamber clips at the four corners of the heat exchanger.
6. Lift heat exchanger straight up using caution not to damage refractory.
7. Reverse above procedure to reinstall.

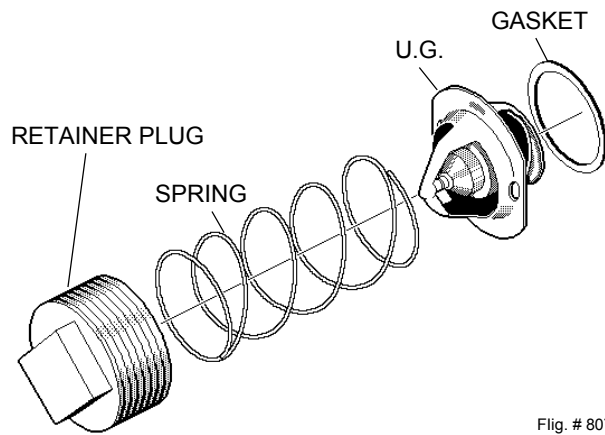

Fig. # 8071.0

To test the operation of the Unitherm Governor, place in hot water (over 110 °F) and watch for movement against spring. If there is no movement, replace unit.

CONTROL IMMERSION WELL REPLACEMENT

1. Shut water off to heater and drain heat exchanger.
2. Remove jacket top panel.
3. Remove old control well with bushing and sleeve, with 7/8" wrench or socket.
4. Slip "O" ring gasket over control well and install in header.

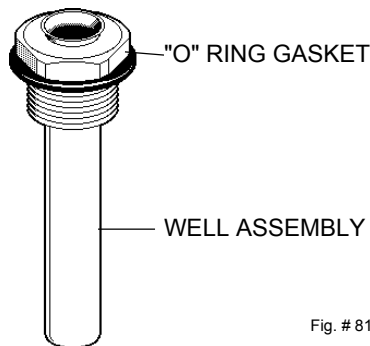

Fig. # 8101.0

UNITHERM GOVERNOR (U.G.) REPLACEMENT

1. Shut water, gas and electricity off, close valves and relieve pressure.
2. Drain heat exchanger.
3. Remove retainer plug located under outlet pipe connection.
4. Remove spring and replace old U.G. with a new U.G.
5. Reverse above procedure to re-install.

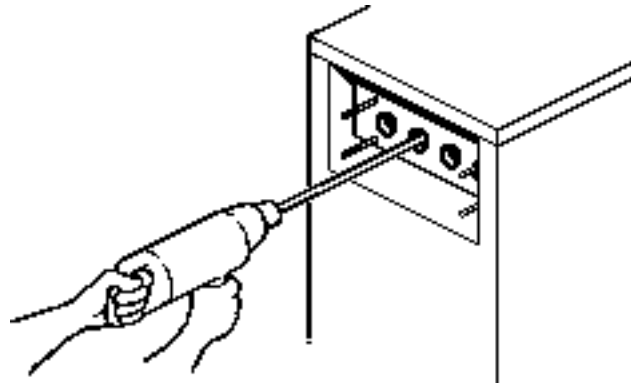

Fig. # 8128.0

TUBE CLEANING PROCEDURE (Typical)

Establish a regular inspection schedule, frequency depending on local water condition and severity of service. Do not let the tubes clog up solidly. Clean out deposits over 1/16" in thickness.

The heater must be cleaned from the rear as shown. It is preferable, however, to remove the heat exchanger and the in/out header for better visibility through the tubes and to be sure the ground-up lime dust does not get into the system.

Note that you do not remove the top panel or the heat exchanger, generally.

After reaming, mount the wire brush in place of the auger and clean out debris remaining in the tubes.

Another method is to remove the heat exchanger, ream tubes and immerse heat exchanger in non-inhibited de-scale solvent.

TUBE REPLACEMENT PROCEDURE

On Raypak units, tube replacement may be effected without rolling, as a temporary means of repair, providing there are two or more tubes rolled in to act as stays on the left or right sides. The "O" rings should provide a seal up to 125 PSI working pressure. Use 3/8" heavy duty reversible drill motor or larger to power the tube roller. If a reversible drill is not available, after rolling the tube in, remove the drill motor and wrench out the roller. A tube roller is available from the factory.

Shut gas and power off to the unit, close the system off and drain the heater. Remove the draft diverter. Remove the access panel and jacket top. Lift the flue collector off. Remove "V" baffles over tube(s) to be replaced. If no pipe unions have been provided, use the header as a union, remove the flange nuts off the inlet-outlet header, break gas connection and slide heater away from piping to allow room to work. Pull wedge clips out of control wells and remove sensing bulbs. Lift heat exchanger straight up and out.

Inspect header gaskets at this time. Unless severed, they are reusable. The tube may be cut out with a hacksaw or hammer and chiseled adjacent to both tube sheets, leaving studs in the tube sheets. Then proceed to collapse studs in the tube sheets with a chisel or screwdriver. Use caution not to cut into the tube sheet. Replacement tubes will have the fins stripped off longer on one end. The long end is inserted into the opening of the tube sheet first; then the short end is fitted through the opposite tube sheet. If the tube ends become dented or bent, straighten at least (4) inches back from the tube end by means of a tapered punch.

Insert tube roller into tube opening up to stop against tube, then push center rod in until roller is tight. Be careful to keep replacement tube squared up 1/8" outside each tube sheet. A loose tube will sometimes pull toward the roller. Attach drill motor to tube roller, holding it straight and level. Proceed to expand tube until the tool begins to grab. At this point, 1/2" to 1" should be exposed on the tool shank. Reverse drill motor or wrench out by hand. Care should be exercised to avoid applying excessive torque during rolling operation and to avoid thinning out any part of the tube wall excessively over .015". Use same procedure at the opposite end of the tube.

Apply line pressure test, and re-roll, if necessary, before reassembly of the heater.

DESOOTING PROCEDURE

CAUTION: SOOT IS COMBUSTIBLE. EXERCISE EXTREME CARE.

Soot can clog areas between fins and cause eventual tube failure. Any sign of soot at the base of the burners or around the outer jacket indicates a need for cleaning.

1. Remove top and flue collector from cabinet.
2. Remove "V" baffles from heat exchanger.
3. Remove burner drawer. (See burner tray removal).
4. Take garden hose and wash heat exchanger, making sure soot is removed from between fins. (Avoid excessive water against refractory).
5. Reassemble-When heater is fired, some steam will form from wet refractory. This is normal.

NOTE: *In extreme cases it may be necessary to remove the heat exchanger completely for cleaning. The simplest method is steam cleaning at the local car wash. DO NOT WIREBRUSH.*

COMBUSTION CHAMBER REMOVAL

To remove combustion chamber, you must first have removed the heat exchanger. Unbolt metal combustion chamber retainer from top and remove combustion chamber panels individually.

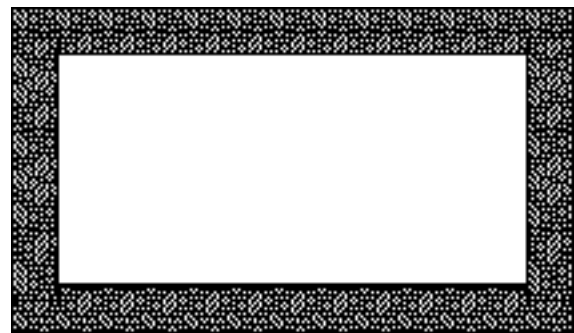

REFRACTORY PANELS TOP VIEW

Fig. # 8155.0

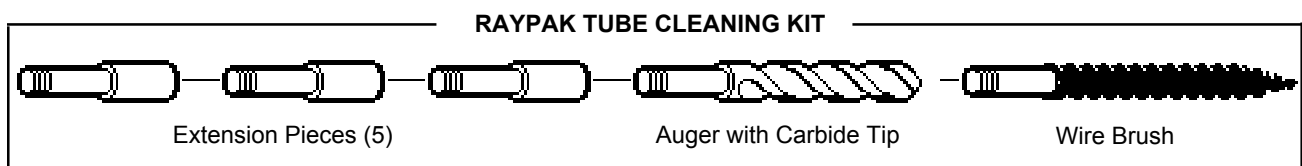

Fig. # 8154.0

SECTION 5 / TROUBLE SHOOTING GUIDE

IMPORTANT NOTICE

These instructions are primarily intended for the use of qualified personnel specifically trained and experienced in the installation of this type of heating equipment and related system components. Installation and service personnel may be required by some states to be licensed. Persons not qualified shall not attempt to install this equipment nor attempt repairs according to these instructions.

MECHANICAL (FOR QUALIFIED SERVICE PERSONNEL ONLY)

PROBLEM	CAUSE	SOLUTION
Harmonics, or whining noise.	U.G. Inoperative.....	Check movement by putting in hot water (110°F or higher). If no movement, replace.
	*Debris or restriction in system.....	Locate the restriction and remove. Flush system and clean.
	*Debris in gas line..... Low flow.....	Remove debris or blow out gas line. Scale forming in heat exchanger - clean heat exchanger and check pool pH and total alkalinity.
Heater going on and off continuously.	Dirty filter.....	Backwash filter.
	Low water level in pool.....	Raise water level.
	External bypass setting out of adjustment.....	Adjust bypass
	*Pressure switch out of adjustment.....	Adjust pressure switch
Liming or scale forming on	Pool water..... heat exchanger.	Recommended pH should be between 7.4 and 7.8 Total alkalinity 100-150 PPM maximum. Hardness 150-400 PPM maximum.
Sooting	High flow rates.....	Reduce by adding manual bypass valve and adjust by putting thermometer in header (1/4" NPT) drain opening. Set bypass so thermometer reads between 105° and 110°F.
	U.G. Inoperative.....	Check movement by putting in hot water (110°F or higher). If no movement, replace.
	*Air starvation.....	Refer to installation instructions.
	*Improper venting.....	Follow recommended installation instructions.
	*Insects or debris clogging burner intake ports.....	Clean burners.
Pilot outage.	Low gas pressure.....	Adjust gas pressure.
	Restricted pilot.....	Clean pilot.
	Weak pilot generator.....	Replace pilot.
Yellow lazy flame	Low gas pressure.....	Adjust gas pressure.
	*Insects or debris clogging burner intake ports.....	Clean burners.
Outer jacket very hot (paint blistered)	*Broken refractory caused by shipping damage or improper combustion..... Excessive sooting of heat exchanger.....	Replace refractory panels. Determine cause of sooting & correct.
Takes long time to heat pool or spa.	Calculate temperature in /hr.....	Heat rise (°/hr.)= Htr. Output Pool gallonage x 8.33 or refer to heater sizing chart. This does not take into account heat loss due to weather.
	Filter not running long enough.....	Reset time clock.
	Dirty filter.....	Clean filter.
	Gas line or meter undersized.....	Refer to installation instructions.
Liming	Bypassing too much water.....	Inspect bypass for movement, if no movement, replace.
	U.G. not functioning.....	Replace if no movement when heated.

(* Usually occurs on initial start-up.)

Leaking at well.	Overacid.....	Replace well and maintain water chemistry properly.
Leaking at heat exchanger.	Overacid.....	Replace heat exchanger and maintain chemistry properly.
Gasket brittle and leaking - (overheated).	Heater running after pump Shuts off.....	See pressure switch adjustment.
	Refractory damage.....	Replace refractory.
	Sooted heater.....	Determine cause of sooting and correct.

ELECTRICAL (MILLIVOLT)

**RAYPAK POOL OR SPA HEATER ELECTRICAL
CHECK WITH MV GAS VALVE**
CAUTION: For qualified service personnel *only*.
 1. Filter must be on with adequate water flow through heater.
 2. Gas valve must be "ON" position. Thermostat set higher than pool water temperature.
 3. Jumpers are for temporary check only. If left in place, they could cause the heater to burn up.

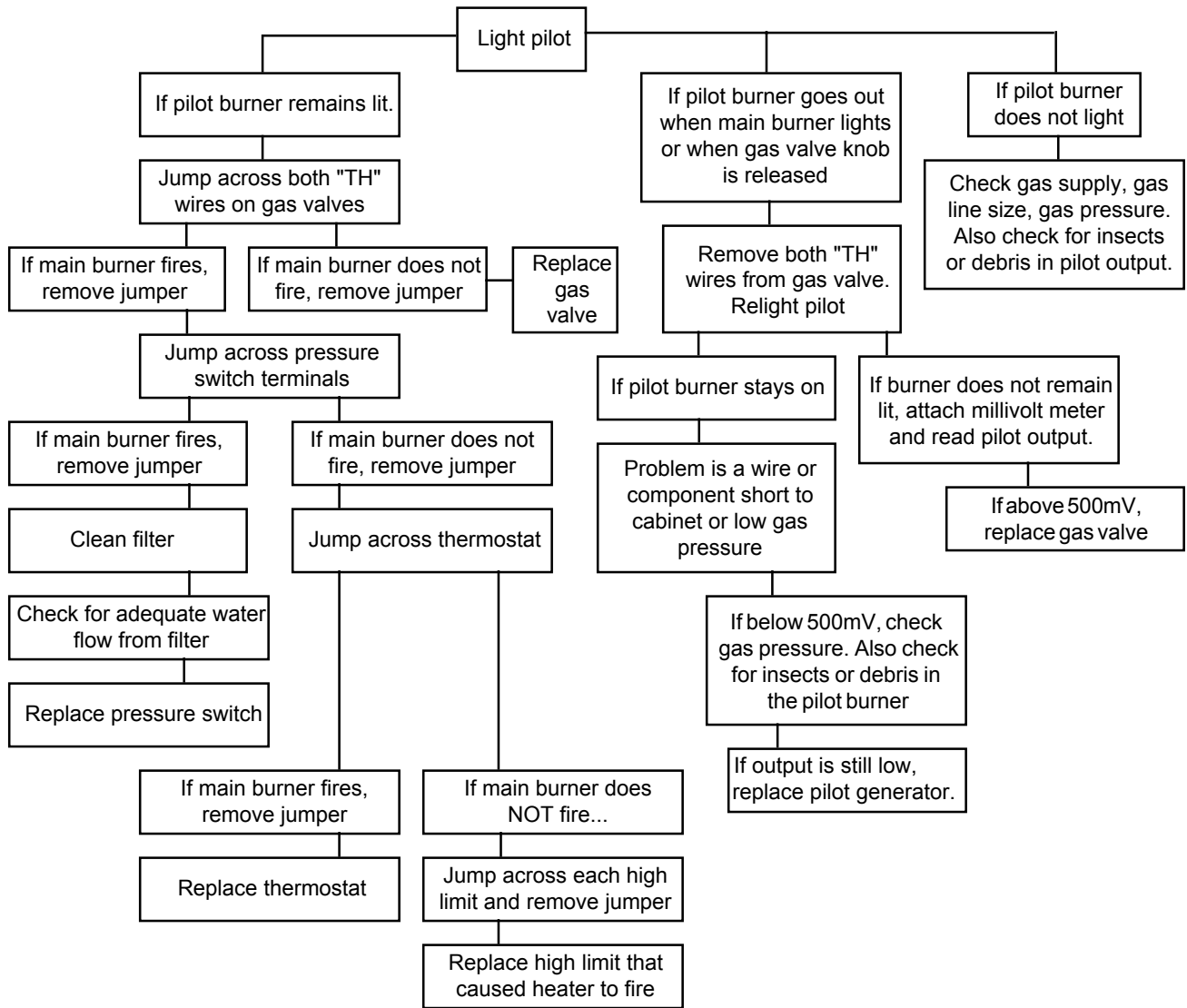

ELECTRICAL (ELECTRONIC IGNITION IID)

<p>WARNING HIGH VOLTAGE For qualified Technicians ONLY</p>
<p>NOTE: Some heaters may be equipped with an ignition module that shuts off pilot gas if pilot fails to light. To reset, interrupt power to heater.</p>

Intermittent Pilot System
TROUBLESHOOTING HONEYWELL S8600

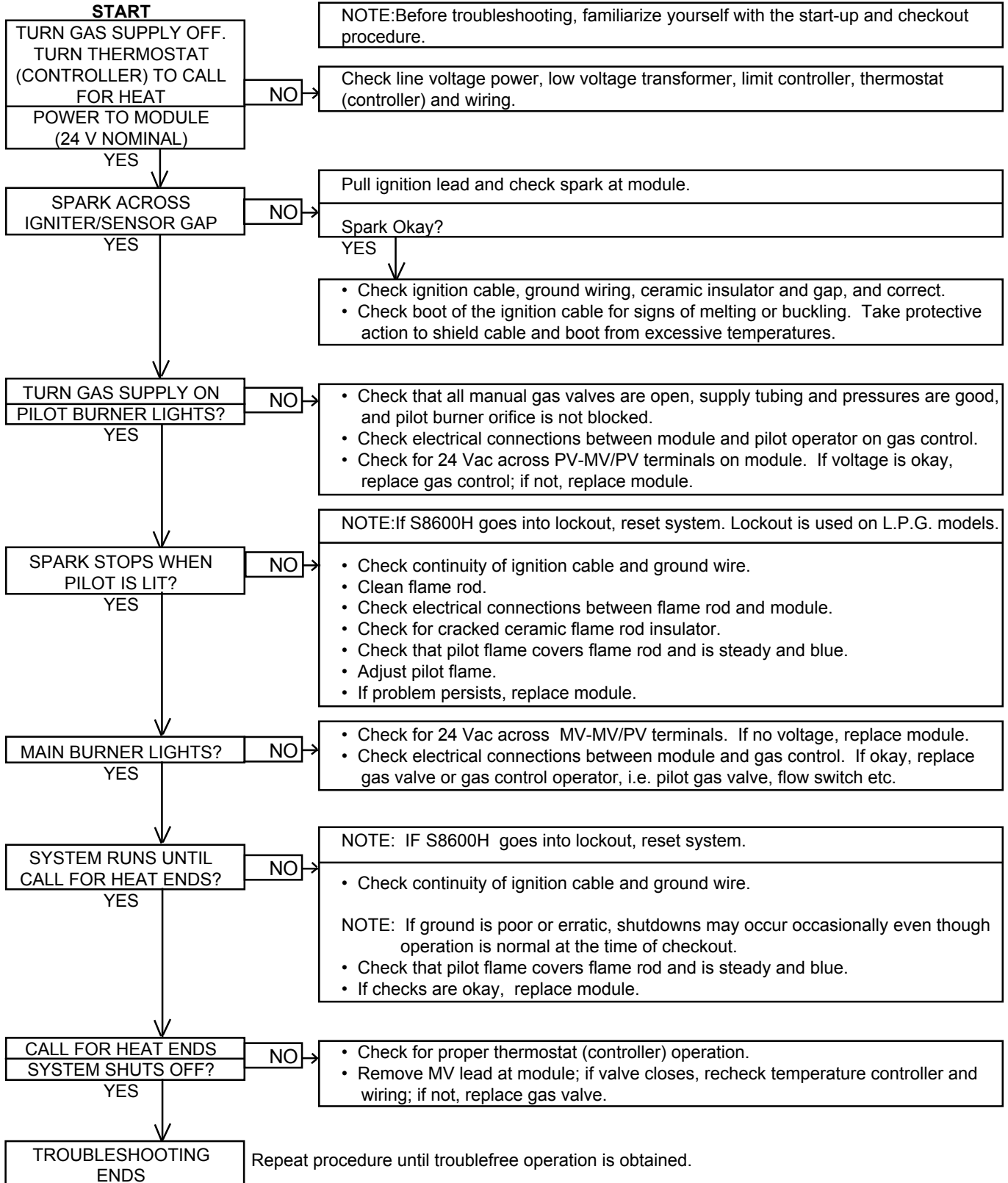

ELECTRICAL (SOLID STATE THERMOSTAT IID)

If the pool/spa/hot tub water is too cold, troubleshoot the system as follows:

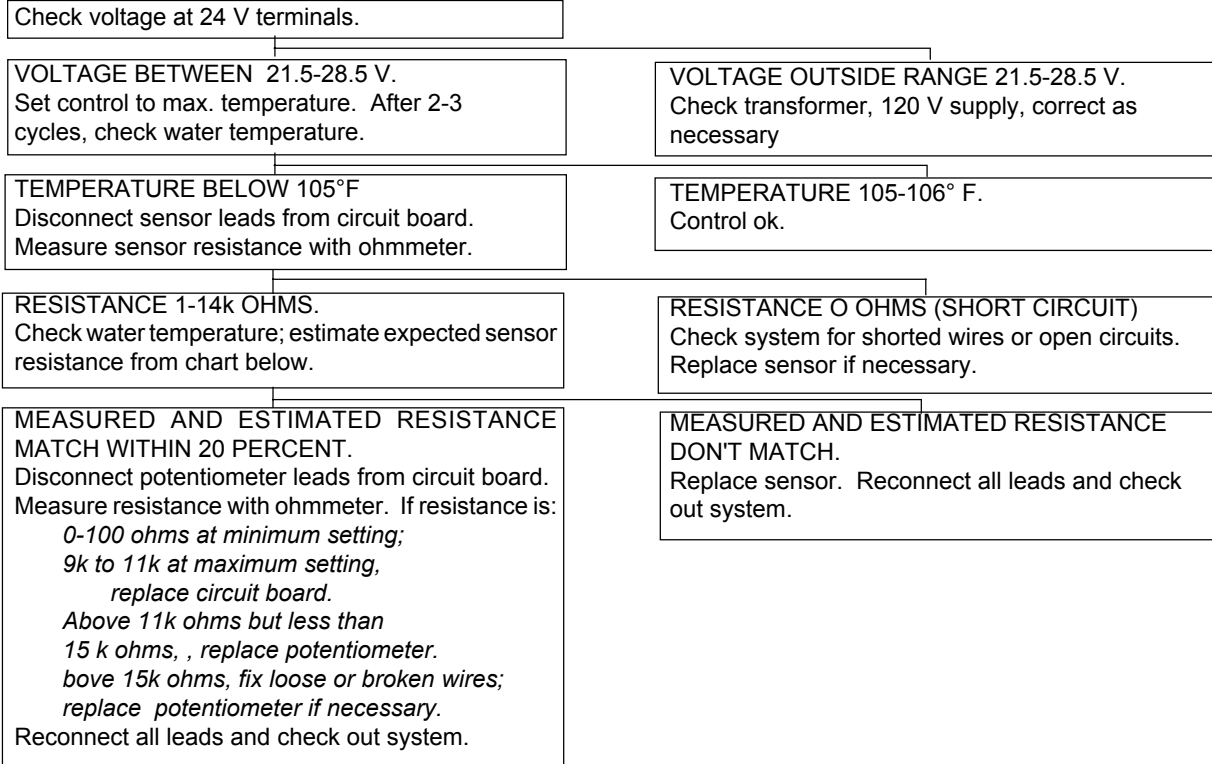

If the pool/spa/hot tub water is too hot, troubleshoot the system as follows:

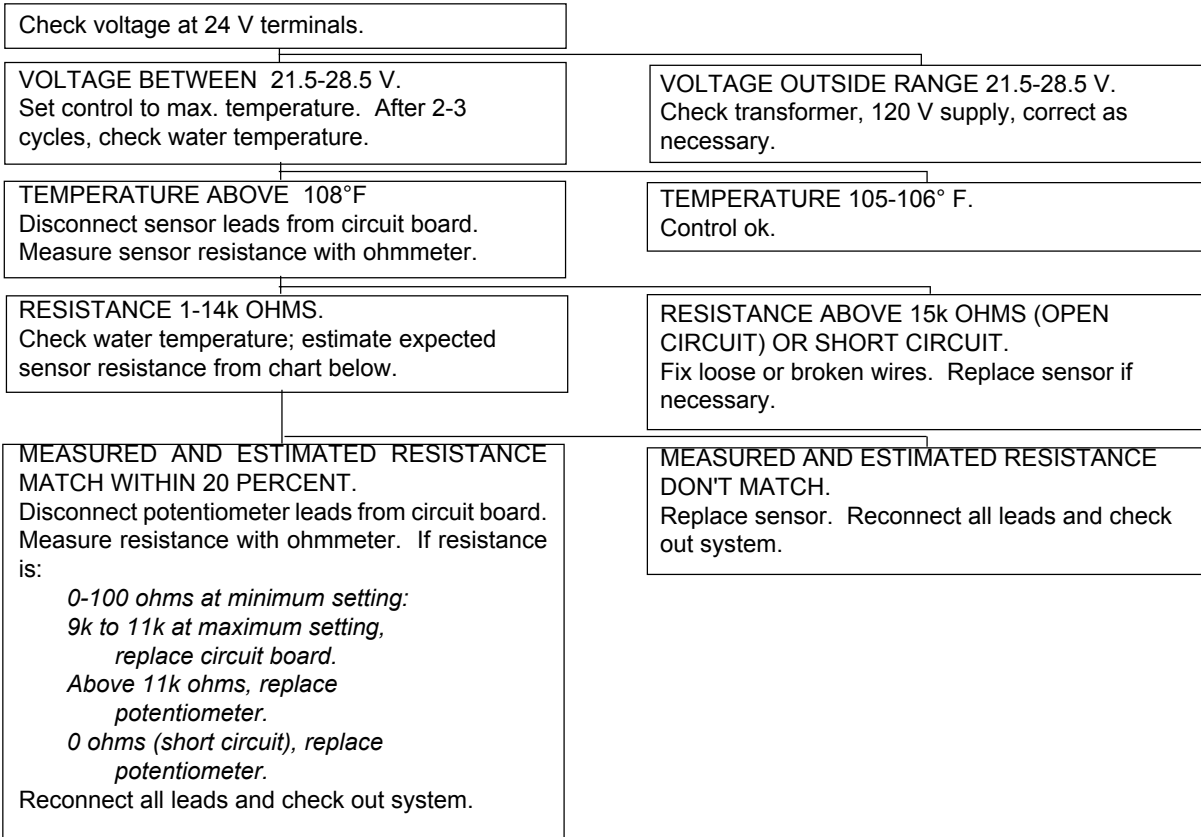

SENSOR RESISTANCE AT VARIOUS TEMPERATURES

Temperature (deg. F)	61	68	70	77	86	88	95	104	106
Resistance (k ohms)	14.92	12.49	11.88	10.00	8.06	7.69	6.53	5.33	5.10

SECTION 6/REPLACEMENT PARTS LIST

NOTE: *To supply the correct part it is important that you state the model number, serial number and type of gas when applicable.*

Any part returned for replacement under standard company warranties must be properly tagged with RAYPAK return parts tag, completely filled in with the heater serial number, model number, etc., and shipped to the Company freight prepaid.

If determined defective by the Company and within warranty, the part will be returned in kind or equal substitution, freight collect. Credit will not be issued.

**RAYPAK, INC.
31111 Agoura Road
Westlake Village, CA 91361-4699**

HEADER DETAIL

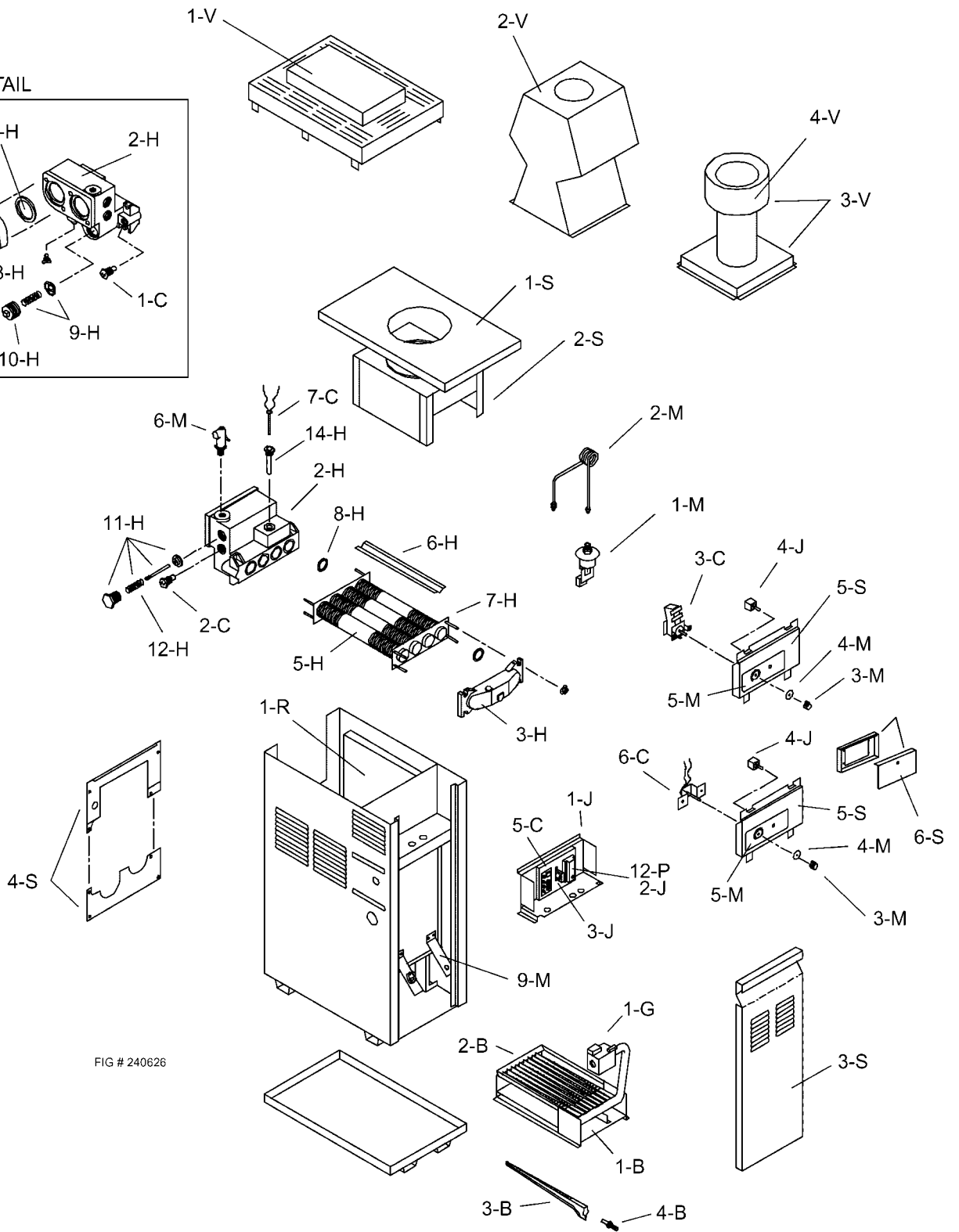
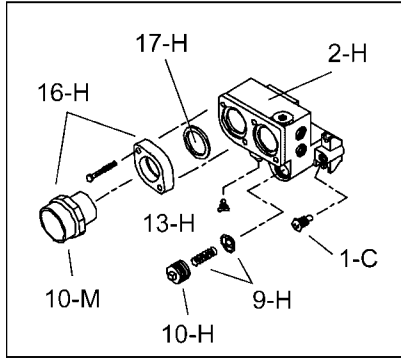

FIG # 240626

HONEYWELL MILLIVOLT PILOT

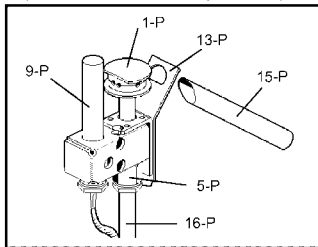

FIG #8107

HONEYWELL IID PILOT

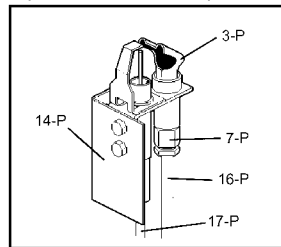

FIG #8124

ROBERTSHAW MILLIVOLT PILOT

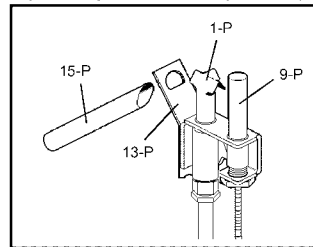

FIG #8123

ROBERTSHAW IID PILOT

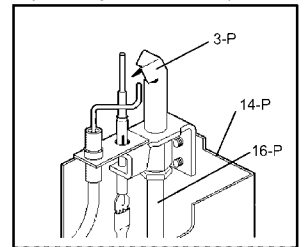

FIG #8122

CALL OUT	DESCRIPTION	PREMIUM BRONZE	CAST IRON
B	BURNER TRAY		
1-B	Burner Tray w/Burners (Sea Level)*	001989F	001989F
	Burner Tray w/Burners and (1) piece manifold (Sea Level)*	007331F	007331F
	Burner Tray w/o Burners (Sea Level)*	001990F	001990F
	Burner Tray w/o Burners and (1) piece manifold (Sea Level)*	007332F	007332F
	Burner Tray w/Gas Valve NAT STG	004848F	004848F
	Burner Tray w/Gas Valve PRO STG	004850F	004850F
	Burner Tray w/Gas Valve NAT IID	004849F	004849F
	Burner Tray w/Gas Valve PRO IID	004851F	004851F
2-B	Burner Hold Down Kit	001991F	001991F
3-B	Burner	301210/10	301210/10
4-B	Burner Orifice Nat. #50 (Sea Level)*	350079/10	350079/10
	Burner Orifice Pro. #57 (Sea Level)*	350083/10	350083/10
C	CONTROLS		
1-C	High Limit 135 F	600892B	600892B
2-C	High Limit 140 F	600893B	600893B
3-C	Thermostat Control MV (Mechanical)	003346F	003346F
4-C	Thermostat Control IID (Solid State)	005389F	005389F
5-C	PC Board	005088B	005088B
6-C	Potentiometer	005087B	005087B
7-C	Temperature Sensor	005088B	005088B
G	GAS VALVE		
1-G	Combination Valve Nat. MV	003898F	003898F
	Combination Valve Pro. MV	003899F	003899F
	Combination Valve Nat. IID	003900F	003900F
	Combination Valve Pro. IID	004306F	004306F
H	HEAT EXCHANGER		
1-H	Heat Exchange Assy. (Complete)	004886F	004962F
2-H	Inlet/Outlet Header	004887F	004963F
3-H	Return Header	004888F	004964F
4-H	Tube Bundle	004896F	004896F
5-H	Heat Exchange Tube**	001999F	001999F
6-H	Baffle Kit***	001622F	001622F
7-H	Carriage Bolt Kit	004889F	004889F
	Stud Bolt Kit	007910F	007910F
8-H	Header Gasket	800086B	800086B
9-H	Unitherm Governor	062234B	062234B
10-H	U.G. Retainer Spring	850254	850254
11-H	Bypass Valve	062235B	062235B
12-H	Bypass Spring	850252	850252
13-H	Drain Valve	500719	500719
14-H	Sensor Well	003765F	003765F
15-H	Well Retaining Clip	300203	300203
16-H	Inlet & Outlet Flange	003766F	003766F
17-H	Flange Gasket 1-1/2" Connections	062236B	062236B
	Flange Gasket 2" Connections	800080B	800080B
J	J BOX/CONTROL BOX		
1-J	Control Box IID w/o Thermostat Nat.	003790F	003790F
	Control Box IID w/o Thermostat Pro.	004309F	004309F
2-J	Ignition Control IID Nat.	004817B	004817B
	Ignition Control IID Pro	004818B	004818B
3-J	Transformer 120/240/24V	005345F	005345F
4-J	Toggle Switch	650761	650761

*FOR ALTITUDES ABOVE 2,000 FEET ABOVE SEA LEVEL, CONSULT THE FACTORY.

**FOR HEATERS BUILT AFTER APRIL 96 USE KIT #002440F

***FOR HEATERS BUILT AFTER APRIL 96 USE KIT #002000F

CALL OUT	DESCRIPTION	PREMIUM BRONZE	CAST IRON
M	MISCELLANEOUS COMPONENTS		
1-M	Pressure Switch	062237B	062237B
2-M	Pressure Switch Tube Assy.	003271F	003271F
3-M	Thermostat Knob	006885F	006885F
4-M	Knob Stop	006886F	006886F
5-M	Dial Plate Std.	900741	900748
	Dial Plate IID	900742	900749
6-M	PRV-75 PSI	501507F	501507F
7-M	Deliming Kit	053868F	053868F
8-M	Wire Harness Std.	004012F	004012F
	Wire Harness IID	004013F	004013F
9-M	Thermal Fuse	005899F	005899F
10-M	CPVC Adapter	005393F	005393F
P	PILOT		
1-P	Pilot Nat. MV	600525B	600525B
	Pilot Pro. MV	600575B	600575B
3-P	Pilot Nat. IID	002003F	002003F
	Pilot Pro IID	002003F	002003F
5-P	Pilot Orifice Nat. MV	003901F	003901F
	Pilot Orifice Pro. MV	003902F	003902F
7-P	Pilot Orifice Nat. IID	003903F	003903F
	Pilot Orifice Pro IID	004308F	004308F
9-P	Pilot Generator MV	600019B	600019B
12-P	Ignition Control IID Nat.	004817B	004817B
	Ignition Control IID Pro	004818B	004818B
13-P	Pilot Mounting Bracket MV	303730	303730
	Pilot Mounting Bracket MV (Plus Models)	006054F	006054F
14-P	Pilot Mounting Bracket IID	304670	304670
	Pilot Mounting Bracket IID (Plus Models)	006055F	006055F
15-P	Lighter Tube (MV Units Only)	052797	052797
16-P	Pilot Tube	004078F	004078F
17-P	Hi Tension Wire IID	002654B	002654B
	Hi Tension Wire IID w/Pilot Electrode	007864F	007864F
R	REFRACTORY		
1-R	Refractory Kit	000992F	000992F
2-R	Refractory Retainer Kit	002006F	002006F
S	SHEETMETAL		
1-S	Jacket Top	002007F	002007F
2-S	Flue Collector	002008F	002008F
3-S	Door Assy.	002010F	002010F
4-S	Access Panel Group	004890F	004890F
5-S	Control Panel Standing Pilot	003788F	003788F
	Control Panel IID Pilot	003789F	003789F
6-S	Poolstat Lock/Cover	006492F	006492F
V	VENTING		
1-V	Stackless Top (Outdoor)	003710	003710
2-V	Drafthood (Indoor)	003723	003723
3-V	Outdoor Stack w/Adapter (Outdoor)	004301	004301
4-V	Outdoor Stack	951018	951018

CONVERSION KITS**	
GAS CONVERSIONS	
Nat. to Pro. Standing Pilot	004690B
Pro. to Nat. Standing Pilot	004691F
Nat. to Pro. Electronic Pilot	N/A
Pro. to Nat. Electronic Pilot	N/A

** Gas Conversions are to be done only by a qualified agency.

**LIMITED WARRANTY
RAYPAK RESIDENTIAL SWIMMING POOL AND SPA HEATERS**

GENERAL

Raypak, Inc. warrants that the cabinet, burner tray (minus controls) and refractory will be free from defects in materials and workmanship under normal use and service for a period of **FIVE YEARS FROM THE DATE OF ORIGINAL PURCHASE FOR A SINGLE FAMILY RESIDENCE (ONE YEAR IF OTHER THAN FOR SINGLE FAMILY RESIDENCE USE)**. All other parts of this product are warranted by Raypak to be free from defects in materials and workmanship under normal use and service for a period of **TWO YEARS FROM THE DATE OF ORIGINAL PURCHASE FOR A SINGLE FAMILY RESIDENCE (ONE YEAR IF OTHER THAN FOR SINGLE FAMILY RESIDENCE USE)**. In accordance with the terms of this warranty, we will furnish a Raypak replacement for any defective part or repair the part at our option. The replacement or repair will be warranted for only the unexpired portion of the original warranty. Labor costs for removal or reinstallation of parts are not covered by this warranty, nor are shipping charges to or from Raypak's designated repair center. This warranty does not cover rusting or corrosion on cabinet or burners that does not affect heater's operation.

WARRANTY CONDITIONS

This warranty applies only to the heater at its original place of installation. This warranty will be void if the heater is installed in violation of applicable local codes and ordinances or if the rating plate or serial number is altered or removed.

WARRANTY EXCLUSION

This warranty does not cover defects or malfunctions resulting from:

- 1. Failure to properly install, operate or maintain the heater in accordance with our printed instructions;*
- 2. Abuse, alteration, accident, fire, flood, freeze and the like;*
- 3. Misuse or neglect, including but not limited to, freeze-ups, operating the heater with the cabinet door off, having flow restrictions or obstructions between the heater outlet and the pool/spa, or not maintaining a proper chemical balance (PH level must be between 7.4 and 7.8 and total alkalinity between 100 and 150 PPM. Total dissolved solids (TDS) must be no greater than 3000 PPM);*
- 4. Use of non-factory authorized accessories or other components in conjunction with the heater.*

HOW TO MAKE A CLAIM

Immediately notify the dealer from whom the heater was purchased, supplying model and serial numbers of the unit, date of purchase, and a description of the problem. The dealer should then promptly contact Raypak about the warranty claim, and for the location of Raypak's nearest designated repair center. (If the dealer for any reason is not available, call or write Raypak directly at the address shown below, Attention: Warranty Service). After such notification has been given and Raypak has advised the location of its designated repair center (which may be the dealer), bring or ship, transportation prepaid, the defective part for replacement or repair to the designated repair center. However, Raypak reserves the right at all times to inspect the claimed defect and verify warranty coverage at its factory.

MISCELLANEOUS

No one is authorized to make any other warranties on our behalf, ANY IMPLIED WARRANTIES, INCLUDING MERCHANTABILITY OR FITNESS FOR A PARTICULAR PURPOSE, SHALL NOT EXTEND BEYOND THE APPLICABLE WARRANTY PERIODS SPECIFIED ABOVE. RAYPAK'S SOLE LIABILITY WITH RESPECT TO ANY DEFECT SHALL BE AS SET FORTH IN THIS WARRANTY AND ANY CLAIMS FOR INCIDENTAL OR CONSEQUENTIAL DAMAGES (INCLUDING DAMAGE FROM WATER LEAKAGE) ARE EXCLUDED. Some states do not allow limitations on how long an implied warranty lasts, or for the exclusion of incidental or consequential damages, so the above limitation or exclusion may not apply to you.

We suggest you immediately complete the information below and retain this Warranty Certificate in the event warranty service is needed. Reasonable proof of the effective date of the warranty must be presented; otherwise, the effective date will be based upon the date of manufacture plus THIRTY (30) Days.

This Warranty gives you specific legal rights, and you may also have other rights which vary from state to state.

Name of Owner	Name of Dealer
Address	Address
Model No.	Serial No.
Date of Purchase	

RAYPAK, INC., 2151 Eastman Avenue, Oxnard, CA 93030 (805) 278-5300 FAX (800) 872-9725 Litho in U.S.A.



www.raypak.com

Raypak, Inc., 2151 Eastman Avenue, Oxnard, CA 93030 (805) 278-1500 FAX (800) 872-9725
Raypak Canada LTD, 2805 Slough Street, Mississauga, Ontario, Canada L4T 1G2 (905) 677-7999 FAX (905) 677-8036
Raypak Australia Pty. Ltd, 7 Geddes St., Mulgrave, Victoria, Australia 3170 (6139) 560 4944 FAX (6139) 560 4974
Litho in U.S.A.