

Features

Automatic EZ-Set™ Coffee Brewer

- Brews up to 15% more than standard brewers with quicker “power boost” recovery.
- Improved brewing system has better temperature accuracy.
- Adjusts automatically to varying water pressure.
- Quicker install saves up to 30 minutes. Pot level sets easily from outside of machine.
- Faster field repairs and quick problem diagnostics by phone; built-in electronic sensors feed back information on brewer malfunctions.
- Cold brew lock-out feature insures coffee brew quality.
- Eliminates dry plug-in damage with electronic tank heater protection system.



Model CEZF15
(2 top warmers)
(decanters not included)

ITEM# _____

PROJECT _____

DATE _____

Line

CEZF15 (2 top)
CEZF15 (3 lower)
CEZF15 APS
CEZF 0/6 Twin

EZ-Set™ Product Line

Gives your customers...

1. More consistent brewing temperature and better low water-pressure performance.
2. More hot water available from faucet, even while brewing.



CEZF15
(2 top warmers)
28800.0001



CEZF15
(3 lower warmers)
28800.0000



CEZF15 APS
29000.0000



CEZF 0/6 Twin
29100.0000

BUNN®

Corporate Offices
1400 Stevenson Drive
Springfield, Illinois 62703
Phone
800-637-8606
217-529-6601
Fax
217-529-6644
Technical Services
800-286-6070
Internet
<http://www.bunnomatic.com>

Western Regional Office
16431 Carmenita Road,
Cerritos, California 90701
Phone
562-926-0764
Fax
562-926-0858

Canadian Office
280 Industrial Parkway South
Aurora, Ontario, L4G 3T9
Phone
905-841-2866
Fax
905-841-2775

BUNN® practices continuous product research and improvement. We reserve the right to change specifications and product design without notice. Such revisions do not entitle the buyer to corresponding changes, improvements, additions or replacements for previously purchased equipment.

Patents
Apply



Dimensions & Specifications

| Model | Product # | Volts | Amps | Tank Heater Watts | Total Watts | Brewing Capacity | Cu. Ft. | Shipping Weight | Cord Attached |
|------------------|------------|---------|-------|-------------------|-------------|------------------|---------|-------------------|---------------|
| CEZF15 (2 top) | 28800.0001 | 120 | 15 | 1425 | 1800 | 4.5 gal./hr. | 3.7 | 30 lbs. (13.6 kg) | Yes |
| CEZF15 (3 lower) | 28800.0000 | 120 | 15 | 1425 | 1800 | 4.5 gal./hr. | 6.3 | 31 lbs. (14.1 kg) | Yes |
| CEZF15 APS | 29000.0000 | 120 | 14.2 | 1425 | 1700 | 4.5 gal./hr. | 5.0 | 33 lbs. (15.0 kg) | Yes |
| CEZF 0/6 Twin | 29100.0000 | 120/240 | 28.75 | 6000 | 6750 | 13.7 gal./hr. | 11.7 | 76 lbs. (34.5 kg) | No |
| CEZF 0/6 Twin* | 29100.0002 | 120/240 | 17.9 | 3500 | 3875 | 13.7 gal./hr. | 11.7 | 76 lbs. (34.5 kg) | No |

Electrical: 120 volt, 15 amp. models require 2-wires plus ground service rated 120V, single phase, 60 Hz.
120/240 volt models require 3-wires plus ground service rated 120/240V, single phase, 60 Hz.

An internal terminal block is configured for connection to a 3-wire plus ground.

*This model requires two power cords, each connected to a 120/240 volt source. Ratings shown apply to each connection, i.e. total brewer consumption is twice the value shown.

Plumbing: 20-90 psi (138-621 kPa). Machines supplied with 1/4" male flare fitting. Twin models supplied with 3/8" male flare fitting.

CEZF15 (2 top)
For more information
see spec. sheet A1.1

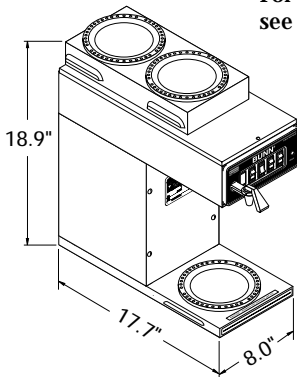

CEZF15 (3 lower)
For more information
see spec. sheet A1.3

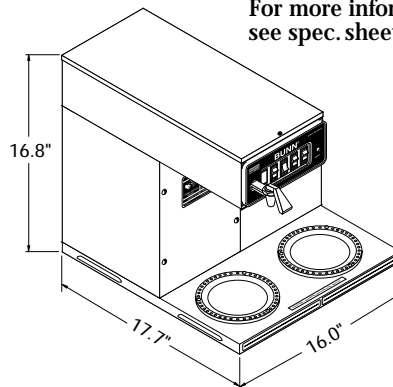

CEZF15 APS
For more information
see spec. sheet A3.1

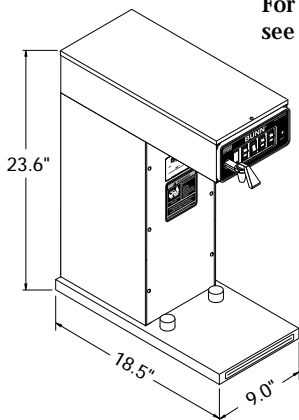

CEZF 0/6 Twin
For more information
see spec. sheet A1.6

