



# **XMODS Street RC Starter Kit**

**User's Guide**

---

Thank you for purchasing your XMODS® Street RC Starter Kit. Please read this user's guide before installing, setting up and using your new product.

## Contents

<b>XMODS® Custom RC Starter Kit</b> .....	<b>3</b>
Your Starter Kit Includes .....	4
<b>Assembling Your XMODS Custom RC</b> .....	<b>5</b>
Assembling the Wheels.....	5
Installing Batteries in the Chassis.....	6
Assembling the Car Antenna .....	7
Redistributing the Car's Weight.....	7
Mounting the Body on the Chassis .....	8
<b>Setting Up Your Controller</b> .....	<b>9</b>
Installing the Battery.....	9
Changing the Steering Control for the Left Hand .....	10
Preparing to Drive .....	11
Controller Unfolded .....	12
<b>Driving Your Car</b> .....	<b>13</b>
Steering Wheel .....	13
Speed Control .....	13
Fine Tuning.....	14
When You Finish Driving .....	14
<b>Care</b> .....	<b>15</b>
Additional Notes.....	15
<b>Optional Upgrades</b> .....	<b>16</b>
<b>Troubleshooting</b> .....	<b>18</b>
<b>RF Emissions Information</b> .....	<b>19</b>
<b>Warranty</b> .....	<b>20</b>



## XMODS® Custom RC Starter Kit

Now you are the proud owner of the next generation of highly-acclaimed XMODS. The new Street series inherits the features of the last generation and has some new features. Your starter kit includes the following features:

- A full set of factory parts to assemble your car.
- Hard plastic storage case to protect and carry your XMODS.
- A digital proportional radio controller with built-in steering and throttle trims for precision driving under varying track conditions.
- A switchable controller for left- and right-handed drivers.
- A collapsible radio controller for easy carrying and storage.
- Redistributable weight so you can optimize driving performance and handling.
- Low weight balance enables sharp cornering—20-inch cornering diameter.
- Faster speed—880 feet per minute!
- Sharper response for acceleration, braking, and steering.

To really get your motor running, customize your XMODS with optional upgrades for both performance and looks. Check out the line-up of XMODS upgrades online at [www.xmodsRC.com](http://www.xmodsRC.com).



## Your Starter Kit Includes

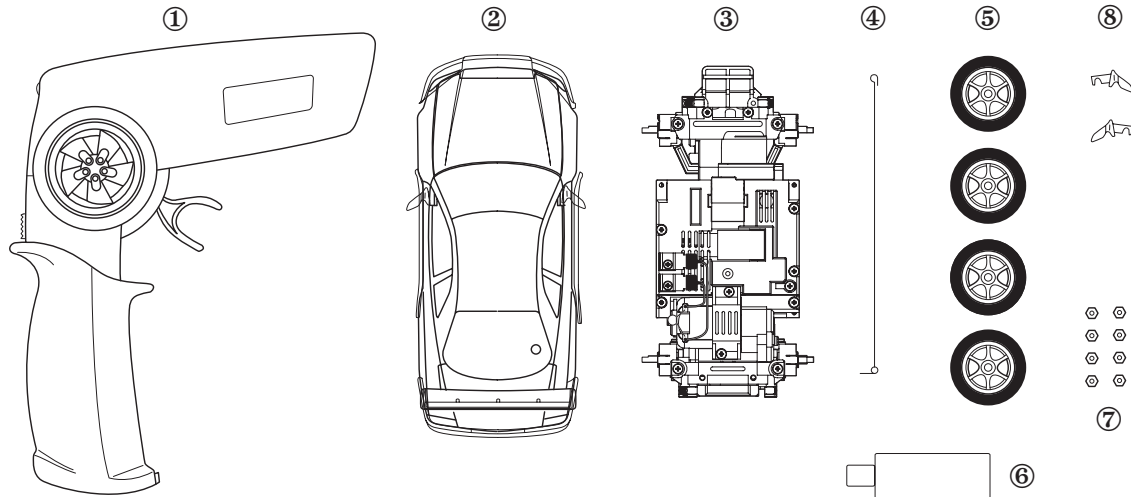

- ① Controller with Antenna
- ② Car Body Assembly
- ③ Car Chassis
- ④ Car Antenna
- ⑤ Wheels with Tires (4)
- ⑥ Lug Wrench

- ⑦ Wheel Nuts (16)
- ⑧ Spare Left/Right Side Mirrors
- ⑨ Screwdriver (not shown)
- ⑩ Decal sheet (not shown)
- ⑪ Spare screws (not shown)

**Note:** Only a spare left side mirror is supplied for '65 Mustang, '67 Camaro, and Firebird.

[www.xmodsRC.com](http://www.xmodsRC.com)



[www.xmodsRC.com](http://www.xmodsRC.com)

## Assembling Your XMODS® Custom RC

### Assembling the Wheels

Wheels with tires are included with your XMODS Street starter kit. Follow the steps below to attach them to your car:

- ① Line up the flat side of the wheel's center with the flat side of the axle.
- ② Gently press the tire onto the chassis.
- ③ Using the supplied Lug Wrench, screw the supplied wheel nut onto the axle and tighten gently. Do not overtighten.
- ④ Repeat steps 1–3 for each wheel.

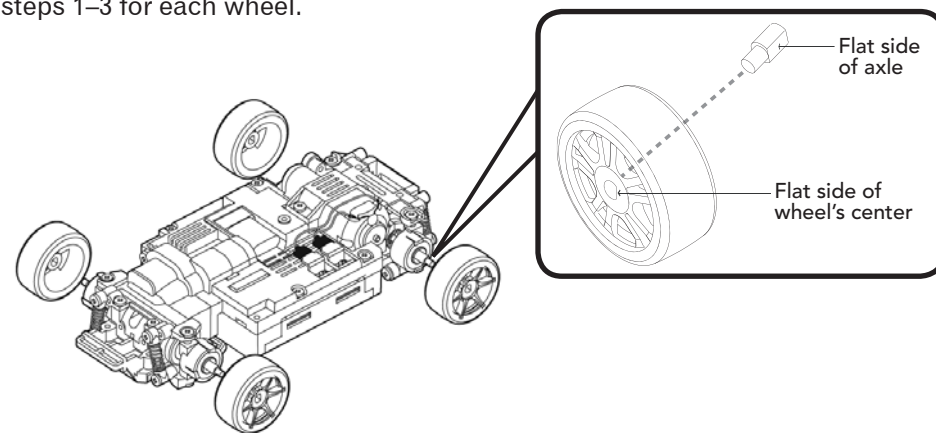

## Installing Batteries in the Chassis

- ① Make sure the power switch on the bottom of the chassis is in the **OFF** position.
- ② Remove the screw on the battery compartment cover with the supplied screwdriver.
- ③ Carefully push either side of the battery compartment cover to disengage the latch, and then lift up the cover.
- ④ Insert four AAA alkaline or rechargeable batteries in the compartments, matching the polarity symbols (+ and -) marked inside.
- ⑤ Snap the cover back in place and replace the screw from step 2.

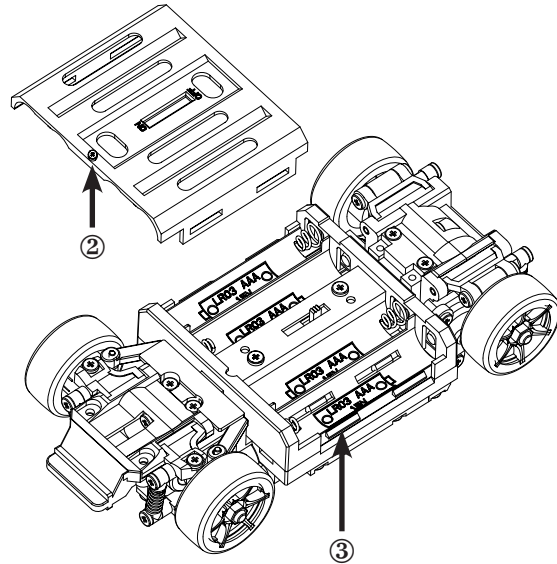

## Assembling the Car Antenna

- ① Remove the antenna screw on the right side of the chassis.
- ② Thread the screw through the metal loop at the base of the antenna.
- ③ Thread the antenna screw back into its slot and tighten.

**Note:** *Be sure not to lose the antenna screw's washer.*

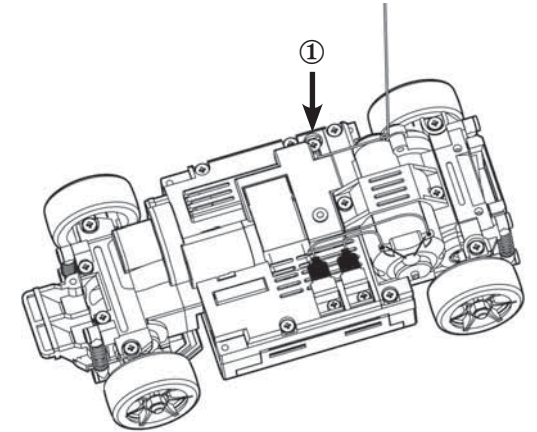

## Redistributing the Car's Weight

You can shift the weight of the batteries to alter your car's center of gravity to optimize handling in different driving conditions.

- ① Remove the two battery compartment screws.
- ② Slide the battery compartment to the desired position.
- ③ Set the screws from step 1 in the holes and tighten until snug.

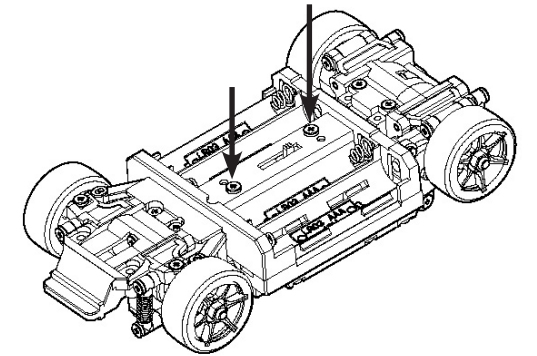

## Mounting the Body on the Chassis

- ① Guide the antenna through the antenna hole in the car body.
- ② Insert the nose of the chassis into the slot inside the front bumper.
- ③ Lower the rear of the body so the tab near the back of the car body enters the slot behind the rear axle. Press gently until you hear a click.

To remove the body from the chassis, press the tab from step 3 gently toward the rear of the vehicle (may need to use fingernails or screwdriver) and lift the rear part of the chassis. Gently slide the car body's nose from the chassis.

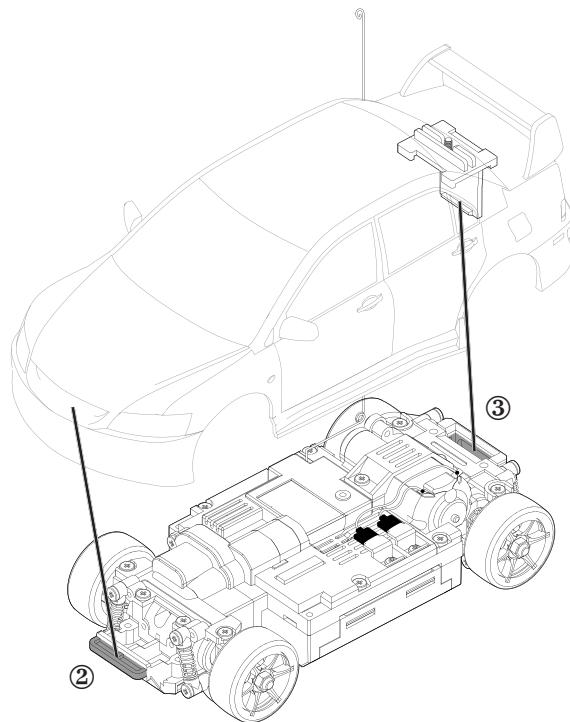

## Setting Up Your Controller

### Installing the Battery

Your controller needs a 9V battery. We recommend 9V alkaline batteries for best performance.

- 1) Make sure the power switch is in the **OFF** position.
- 2) Place your finger in the battery compartment cover and slide (in the direction shown) until the cover unlatches.
- 3) Place one 9V battery in the compartment, matching the polarity symbols (+ and -) marked inside.
- 4) Replace the cover and snap it shut.

*Note:* You cannot shut the cover if the battery has been inserted incorrectly.

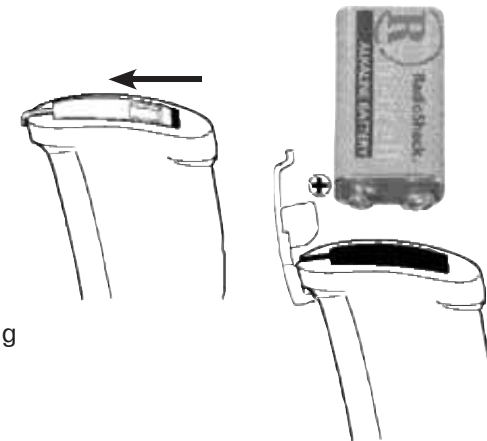

### Battery Notes

- When you notice the LED dims or the range of your car decreases, replace the battery.
- Dispose of old batteries promptly and properly. Do not burn or bury batteries.
- Use only fresh batteries of the required size and recommended type.
- Do not mix old and new batteries, different types of batteries (standard, alkaline, or rechargeable), or rechargeable batteries of different capacities.
- If you do not plan to use the vehicle for several days, remove the batteries. Batteries can leak chemicals that can destroy electronic parts.



## Changing the Steering Control for the Left Hand

- 1) Unscrew the screw on the opposite side of the controller from the steering wheel.
- 2) Pull out the steering wheel and insert it on the other side, keeping the widest channel on the shaft in the bottom position.
- 3) Align the three tabs (two small, one larger) on the inside of the locking plate with the controller, and tighten the screw.
- 4) Set **USER** on top of the controller to **L** for left-handed steering.

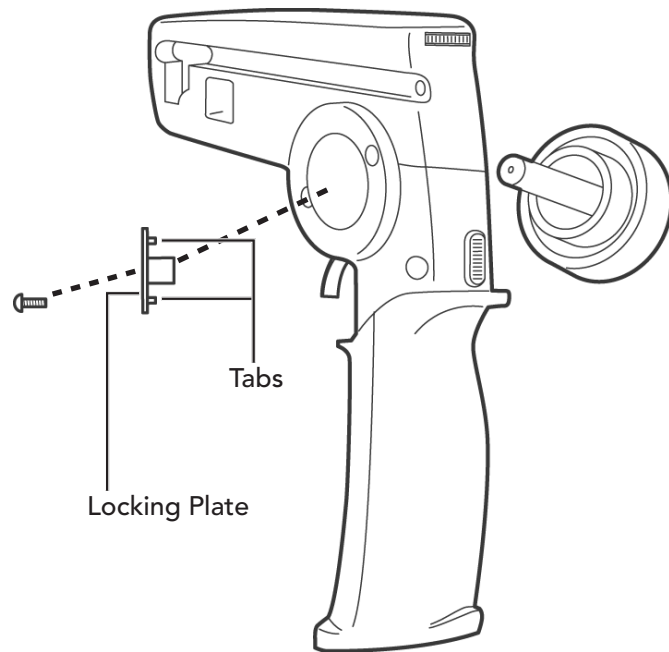

## Preparing to Drive

- ① Unfold the controller until it clicks.
- ② Remove the antenna from the storage channel on the side of the controller.
- ③ Thread your antenna into the antenna connector on top of the controller, and turn until snug.

**Note:** Fully extend the antenna before driving.

### To store after use:

- ① Unscrew the antenna and place it back in the storage channel.
- ② Slide the **Lock** switch to fold the controller.

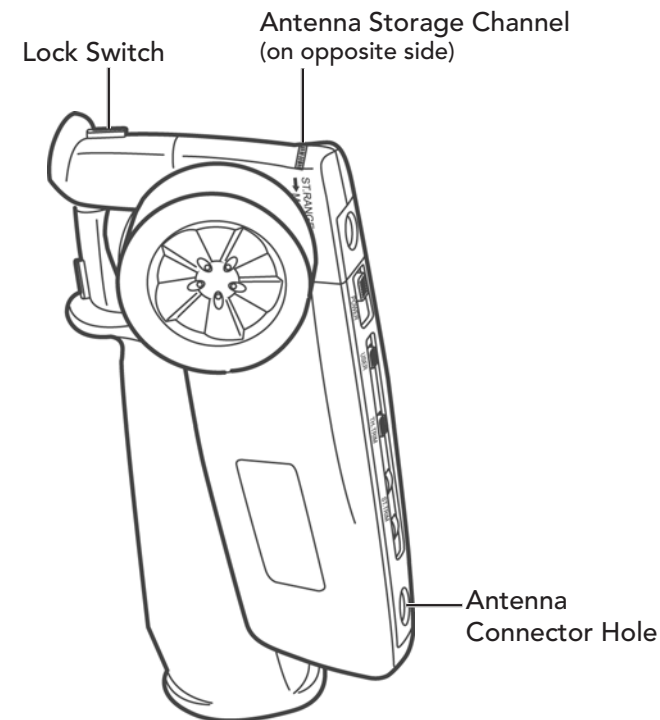

## Controller Unfolded

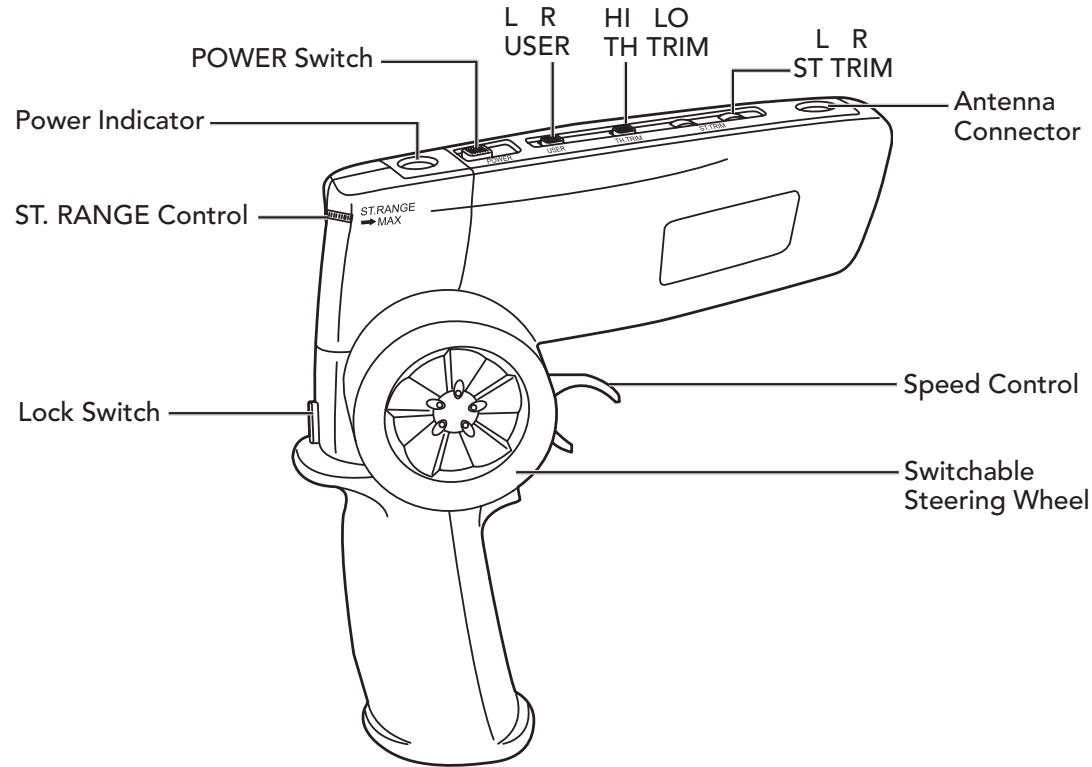

## Driving Your Car

After following your controller's setup instructions (beginning on page 9), turn on the controller and car. The car's power switch is on the bottom of the chassis.

### Steering Wheel

- Rotate wheel left or right to steer.
- Release wheel to go straight.

### Speed Control

*While your car is not in motion*

- Pull the trigger to move forward.
- Push the trigger to drive in reverse.

*While your car is in forward motion*

- Push and release the trigger to brake.
- Push the trigger twice to drive in reverse.



## RIGHT-HANDED STEERING

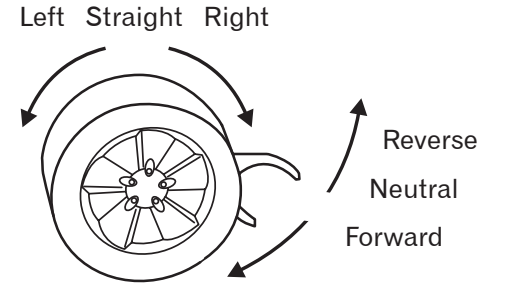

## LEFT-HANDED STEERING

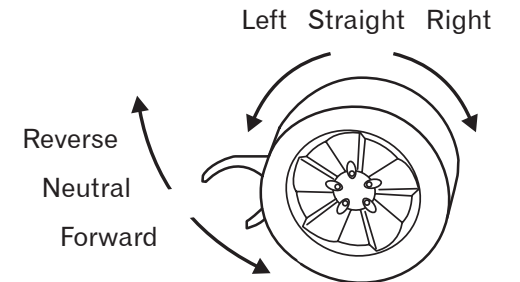

## Fine Tuning

### Steering Range

Set **ST RANGE** to adapt your car's steering angle to different track conditions. Set it to **MAX** (right) for sharp turns and to **MIN** (left) for loose turns.

### Throttle Trim

Set **TH TRIM** on top of the controller to control your car's acceleration. Set it to **LO** for maximum maneuverability on a race track with lots of curves and **HI** for maximum speed.

### Steering Trim

If your car does not drive straight when you release the steering wheel, adjust **ST TRIM** on top of the controller. Place the vehicle on a block or turn it over so the tires do not touch the ground. Turn the transmitter and vehicle on, and press **L** or **R ST TRIM** until the tires point directly forward.

*(Note: ST TRIM will revert to the factory setting when the controller is turned off.)*

### When You Finish Driving

- Slide the power switch on the controller to the **OFF** position.
- Slide the power switch on the bottom of the car to the **OFF** (rear) position.
- To store your controller, unscrew the antenna and place it in its channel in the controller. Slide the **Lock** switch to fold your controller.
- Make it a habit to remove the batteries from your vehicle after you finish driving. Over time, batteries can leak chemicals that may destroy electronic parts.



## Care

- Keep your XMODS car and controller dry; if they get wet, wipe them dry immediately.
- Use and store only in normal temperature environments.
- Running your XMODS continuously for long periods can generate high heat levels.
- Handle your XMODS car and controller carefully and do not drop them.
- Keep away from dust and dirt. You can wipe your car and controller with a damp cloth occasionally to keep them looking new.
- Modifying or tampering with your XMODS' internal components can cause a malfunction and might invalidate its warranty and void your FCC authorization to operate it. If your XMODS is not performing as it should, take both the car and the controller to your local XMODS dealer for assistance.

### Additional Notes

- XMODS Street car bodies and chassis are not compatible with 1st Generation or EVO series. All parts are compatible only with XMODS Street products.
- CB radios and other RC controllers could interfere with your ability to control the car. If this happens, increase the distance between the interfering devices until normal control of your vehicle resumes.
- You cannot operate your car near devices with controllers that use the same frequency. The frequency used in your XMODS is identified by Band Number, which is labeled on the top center of the chassis. See the following frequency chart:

Band No.	Frequency	Band No.	Frequency
1	26.995	7	26.975
2	27.045	8	27.025
3	27.095	9	27.075
4	27.145	10	27.125
5	27.195	11	27.175
6	27.255	12	27.225





## Optional Upgrade Kits

Modify and personalize your XMODS Street car with these upgrade and decorative kits. Check out the entire XMODS line and accessories online at [www.xmodsRC.com](http://www.xmodsRC.com).

### Stage 2 Motor Upgrade

60-417

Your XMODS Street starter kit comes with a Stage 1 Motor. With the Stage 2 upgrade, your XMODS car goes from 27,000 RPM to 30,000 RPM for faster top speed. Ideal on straightaways when you need to get ahead of the competition. This kit also includes pitch gears for various speed settings.

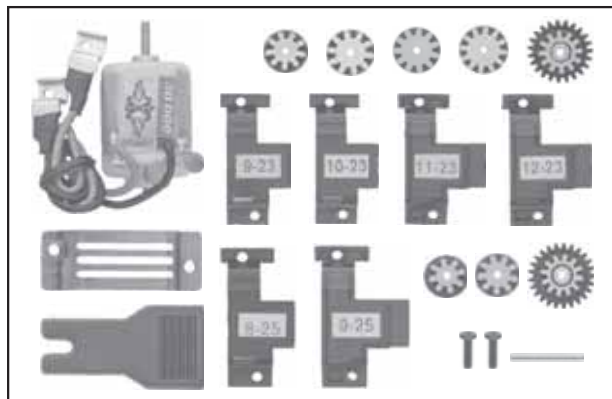

### All Wheel Drive Upgrade

60-390

Increase the agility and handling of your XMODS car with this upgrade kit. By distributing the power to all four wheels, you maximize your car's traction on the race course. Take turns more smoothly than with the standard 2-wheel drive. This kit is ideal for courses with lots of turns, and will give you an edge over your opponents.

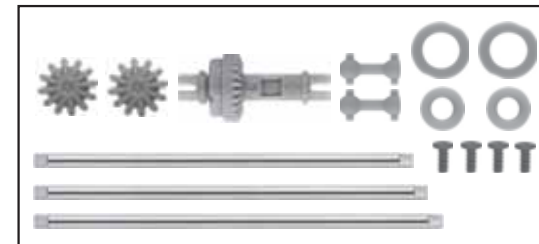

### Ground Effects Lighting Kit

60-483

Not only can you make your car move faster and turn more quickly, but also can light it up! The light turns on when you turn on the car, and doesn't require batteries of its own. Make your XMODS car stand out with this cool green undercarriage light kit for XMODS Street.



## Troubleshooting

### Vehicle does not move or cannot be steered.

- Batteries for vehicle and/or controller are weak or dead. Replace the batteries (or recharge if you are using rechargeable batteries for the vehicle).

*Note: When the power light on the controller blinks, the battery is low. Replace the battery.*

- Static discharge might have caused controller malfunction. Turn the controller off and then back on.
- Check the wheel mechanisms for lint, thread, hair, or dust.
- Move closer to the vehicle and try again.

### Vehicle does not drive straight even when you release the steering wheel.

- Adjust **ST TRIM** on the controller. See “**Steering Trim**” on Page 14.

### Controlling range seems to become shorter.

- Check the frequency of neighbor driver’s vehicle. The same or adjacent frequency vehicles might interfere each other. See “**Additional Notes**” on Page 15.



## RF Emissions Information

This equipment has been tested and found to comply with the limits for a Class B digital device, pursuant to Part 15 of the FCC Rules. These limits are designed to provide reasonable protection against harmful interference in a residential installation. This equipment generates, uses and can radiate radio frequency energy and, if not installed and used in accordance with the instructions, may cause harmful interference to radio communications. However, there is no guarantee that interference will not occur in a particular installation. If this equipment does cause harmful interference to radio or television reception, which can be determined by turning the equipment off and on, the user is encouraged to try to correct the interference by one or more of the following measures:

- Reorient or relocate the receiving antenna.
- Increase the separation between the equipment and receiver.
- Connect the equipment into an outlet on a circuit different from that to which the receiver is connected.
- Consult the dealer or an experienced radio/TV technician for help

Changes or modifications not expressly approved by Ignition L.P. may cause interference and void the user’s authority to operate the equipment.

This device complies with part 15 of the FCC Rules. Operation is subject to the following two conditions: (1) This device may not cause harmful interference, and (2) this device must accept any interference received, including interference that may cause undesired operation.

Frequency range: 26.975 – 27.255 MHz. Field strength: 27.125 MHz – 75.3 dB $\mu$ V/m at 3 m.

Only use the antenna attached to this product.



Protect the environment by recycling used electronics.  
Go to [E-CyclingCentral.com](http://E-CyclingCentral.com) to find a recycle center near you.



## 90-Day Limited Warranty

Ignition L.P. warrants this product against defects in materials and workmanship under normal use by the original purchaser for **ninety (90) days** after the date of purchase. **IGNITION L.P. MAKES NO OTHER EXPRESS WARRANTIES.**

This warranty does not cover: (a) damage or failure caused by or attributable to abuse, misuse, failure to follow instructions, improper installation or maintenance, alteration, accident, Acts of God (such as floods or lightning), or excess voltage or current; (b) damage or failure caused by loss of control, loss of signal between the toy and its controller due to excessive range or low power, impact, violent contact, collision or rough use; (c) improper or incorrectly performed repairs by persons who are not a Ignition L.P. Authorized Service Facility; (d) consumables such as fuses or batteries; (e) ordinary wear and tear or cosmetic damage; (f) transportation, shipping or insurance costs; (g) costs of product removal, installation, set-up service, adjustment or reinstallation; and (h) claims by persons other than the original purchaser.

Should a problem occur that is covered by this warranty, take the product and the sales receipt as proof of purchase date to the place of purchase. Ignition L.P. will, at its option, unless otherwise provided by law: (a) repair the product without charge for parts and labor; (b) replace the product with the same or a comparable product; or (c) refund the purchase price. All replaced parts and products, and products on which a refund is made, become the property of Ignition L.P. New or reconditioned parts and products may be used in the performance of warranty service. Repaired or replaced parts and products are warranted for the remainder of the original warranty period. You will be charged for repair or replacement of the product made after the expiration of the warranty period.

**ALL IMPLIED WARRANTIES, INCLUDING THE IMPLIED WARRANTY OF MERCHANTABILITY AND, IF APPLICABLE, THE IMPLIED WARRANTY OF FITNESS FOR A PARTICULAR PURPOSE, SHALL EXPIRE ON THE EXPIRATION OF THE STATED WARRANTY PERIOD.**

**EXCEPT AS DESCRIBED ABOVE, IGNITION L.P. SHALL HAVE NO LIABILITY OR RESPONSIBILITY TO THE PURCHASER OF THE PRODUCT OR ANY OTHER PERSON OR ENTITY WITH RESPECT TO ANY LIABILITY, LOSS OR DAMAGE CAUSED DIRECTLY OR INDIRECTLY BY USE OR PERFORMANCE OF THE PRODUCT OR ARISING OUT OF ANY BREACH OF THIS WARRANTY, INCLUDING, BUT NOT LIMITED TO, ANY DAMAGES RESULTING FROM INCONVENIENCE AND ANY LOSS OF TIME, DATA, PROPERTY, REVENUE, OR PROFIT AND ANY INDIRECT, SPECIAL, INCIDENTAL, OR CONSEQUENTIAL DAMAGES, EVEN IF IGNITION L.P. HAS BEEN ADVISED OF THE POSSIBILITY OF SUCH DAMAGES.**

Some States do not allow limitations on how long an implied warranty lasts or the exclusion or limitation of incidental or consequential damages, so the above limitations or exclusions may not apply to you. This warranty gives you specific legal rights, and you may also have other rights which vary from State to State. You may contact Ignition L.P. at:

Ignition L.P., 3102 Maple Ave Suite 450, Dallas, TX 75201

11/08

03A09  
INS-3300-US-09-B  
Printed in China

