

# PRO-FORM<sup>®</sup>

# 320

Model No. PFEL2926.0

Serial No. \_\_\_\_\_

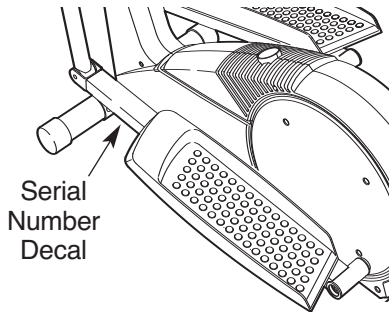

## USER'S MANUAL

### QUESTIONS?

As a manufacturer, we are committed to providing complete customer satisfaction. If you have questions, or if parts are damaged or missing, PLEASE CONTACT OUR CUSTOMER SERVICE DEPARTMENT DIRECTLY.

CALL TOLL-FREE:

**1-888-533-1333**

Mon.–Fri., 6 a.m.–6 p.m. MST

ON THE WEB:

[www.proformservice.com](http://www.proformservice.com)

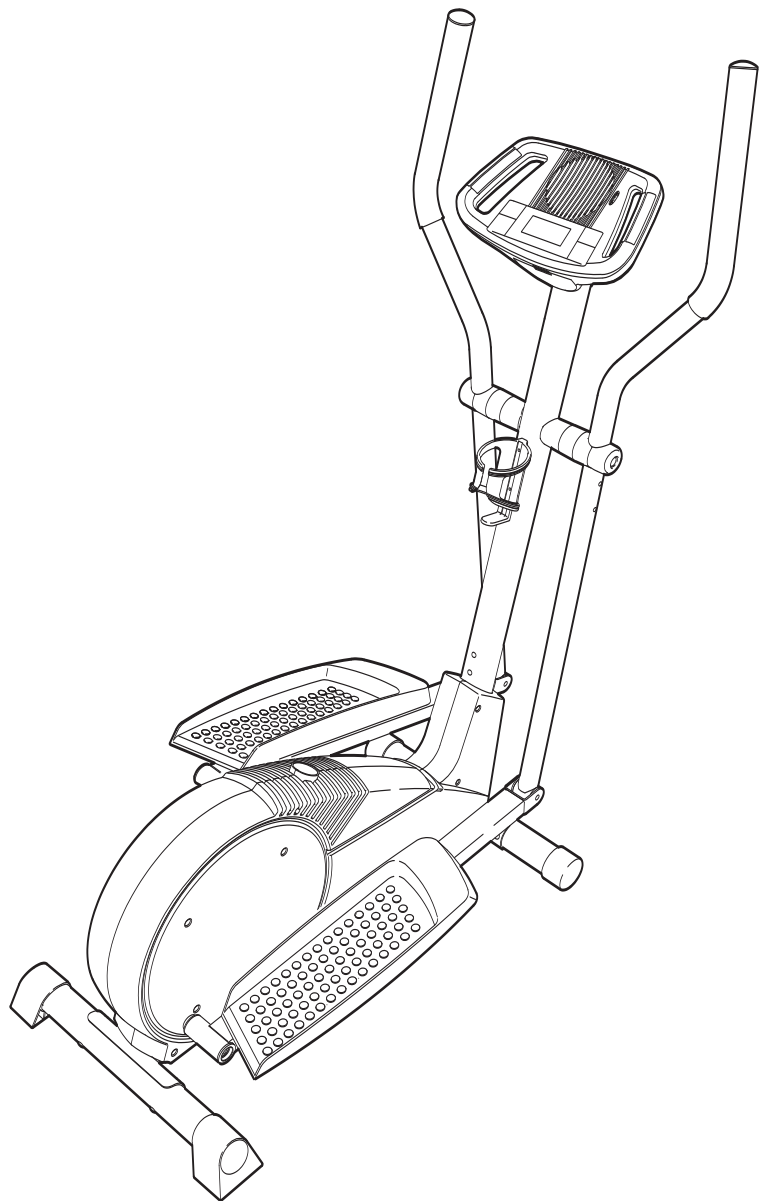

### **⚠ CAUTION**

Read all precautions and instructions in this manual before using this equipment. Keep this manual for future reference.



Visit our website at

[www.proform.com](http://www.proform.com)

new products, prizes,  
fitness tips, and much more!

# PRO-FORM<sup>®</sup>

## 320

---

### TABLE OF CONTENTS

IMPORTANT PRECAUTIONS .....	3
BEFORE YOU BEGIN .....	4
ASSEMBLY .....	5
HOW TO USE THE ELLIPTICAL EXERCISER .....	9
MAINTENANCE AND TROUBLESHOOTING .....	12
CONDITIONING GUIDELINES .....	13
PART LIST .....	14
EXPLODED DRAWING .....	15
HOW TO ORDER REPLACEMENT PARTS .....	.Back Cover
LIMITED WARRANTY .....	.Back Cover

# IMPORTANT PRECAUTIONS

**⚠️ WARNING:** To reduce the risk of serious injury, read the following important precautions before using the elliptical exerciser.

1. Read all instructions in this manual and all warnings on the elliptical exerciser before using the elliptical exerciser.
2. It is the responsibility of the owner to ensure that all users of the elliptical exerciser are adequately informed of all precautions.
3. The elliptical exerciser is intended for home use only. Do not use the elliptical exerciser in a commercial, rental, or institutional setting.
4. Keep the elliptical exerciser indoors, away from moisture and dust. Place the elliptical exerciser on a level surface, with a mat beneath it to protect the floor or carpet. Make sure that there is enough clearance around the elliptical exerciser to mount, dismount, and use it.
5. Inspect and properly tighten all parts regularly. Replace any worn parts immediately.
6. Keep children under 12 and pets away from the elliptical exerciser at all times.
7. The elliptical exerciser should not be used by persons weighing more than 250 pounds.
8. Wear appropriate athletic clothes and athletic shoes while using the elliptical exerciser.
9. Always hold the handles on the console or the handlebars while mounting, dismounting, or using the elliptical exerciser.
10. Keep your back straight while using the elliptical exerciser; do not arch your back.
11. The pulse sensor is not a medical device. Various factors, including the user's movement, may affect the accuracy of heart rate readings. The pulse sensor is intended only as an exercise aid in determining heart rate trends in general.
12. If you feel pain or dizziness while exercising, stop immediately and cool down.
13. When you stop exercising, allow the pedals to slowly come to a stop.
14. The warning decal shown on page 4 has been applied to the elliptical exerciser. If the decal is missing, or if it is not legible, call toll-free telephone number on the front cover of this manual and order a free replacement decal. Apply the decal in the location shown.

**⚠️ WARNING:** Before beginning this or any exercise program, consult your physician. This is especially important for persons over the age of 35 or persons with pre-existing health problems. Read all instructions before using. ICON assumes no responsibility for personal injury or property damage sustained by or through the use of this product.

# BEFORE YOU BEGIN

Congratulations for selecting the new PROFORM® 320. The PROFORM 320 is an incredibly smooth exerciser that moves your feet in a natural elliptical path, minimizing the impact on your knees and ankles. And the unique PROFORM 320 features adjustable resistance and a simple-to-use console to help you get the most from your exercise. Welcome to a whole new world of natural, elliptical-motion exercise from PROFORM.

**For your benefit, read this manual carefully before using the elliptical exerciser.** If you have questions after reading this manual, see the front cover of this

manual. To help us assist you, please note the product model number and serial number before contacting us. The model number is PFEL2926.0. The serial number is found on a decal attached to the elliptical exerciser (see the front cover of this manual for the location of the decal).

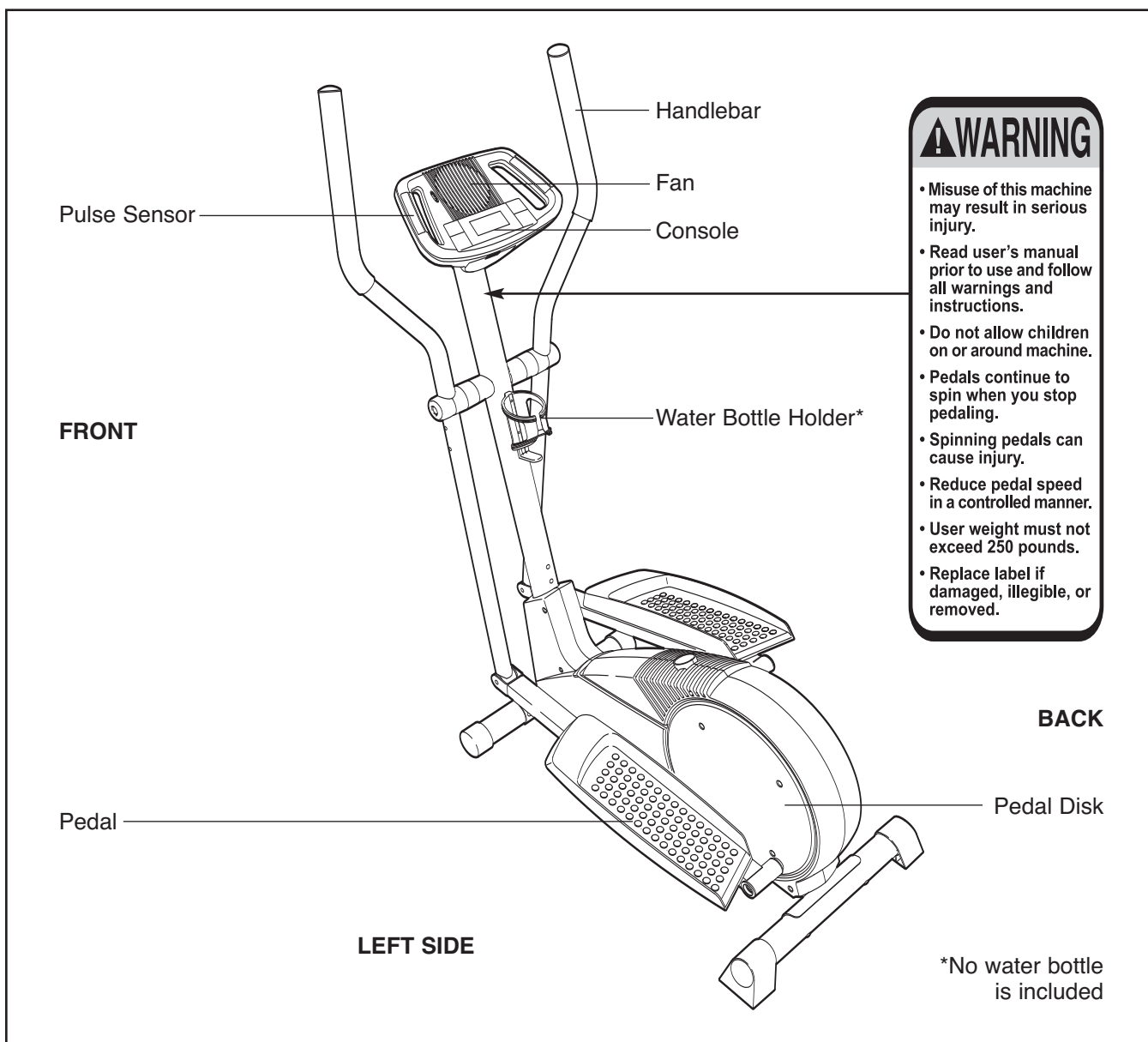

**To avoid a registration fee for any service needed under warranty, you must register the elliptical exerciser at [www.proformservice.com/registration](http://www.proformservice.com/registration).**

Before reading further, please familiarize yourself with the parts that are labeled in the drawing below.



# ASSEMBLY

To hire an authorized service technician to assemble the elliptical exerciser, call toll-free 1-800-445-2480.

**Assembly requires two persons.** Place all parts of the elliptical exerciser in a cleared area and remove all packing materials; do not dispose of the packing materials until assembly is completed. **Assembly requires the included hex keys and your own adjustable wrench** , **Phillips screwdriver** , and **rubber mallet** .

As you assemble the elliptical exerciser, use the drawings below to identify small parts. The number in parentheses below each drawing is the key number of the part. The number following the parentheses is the quantity needed for assembly. **Note: Some small parts shown in the assembly steps may be pre-assembled. If a part is not found in the parts bag, check to see if it is pre-assembled.**

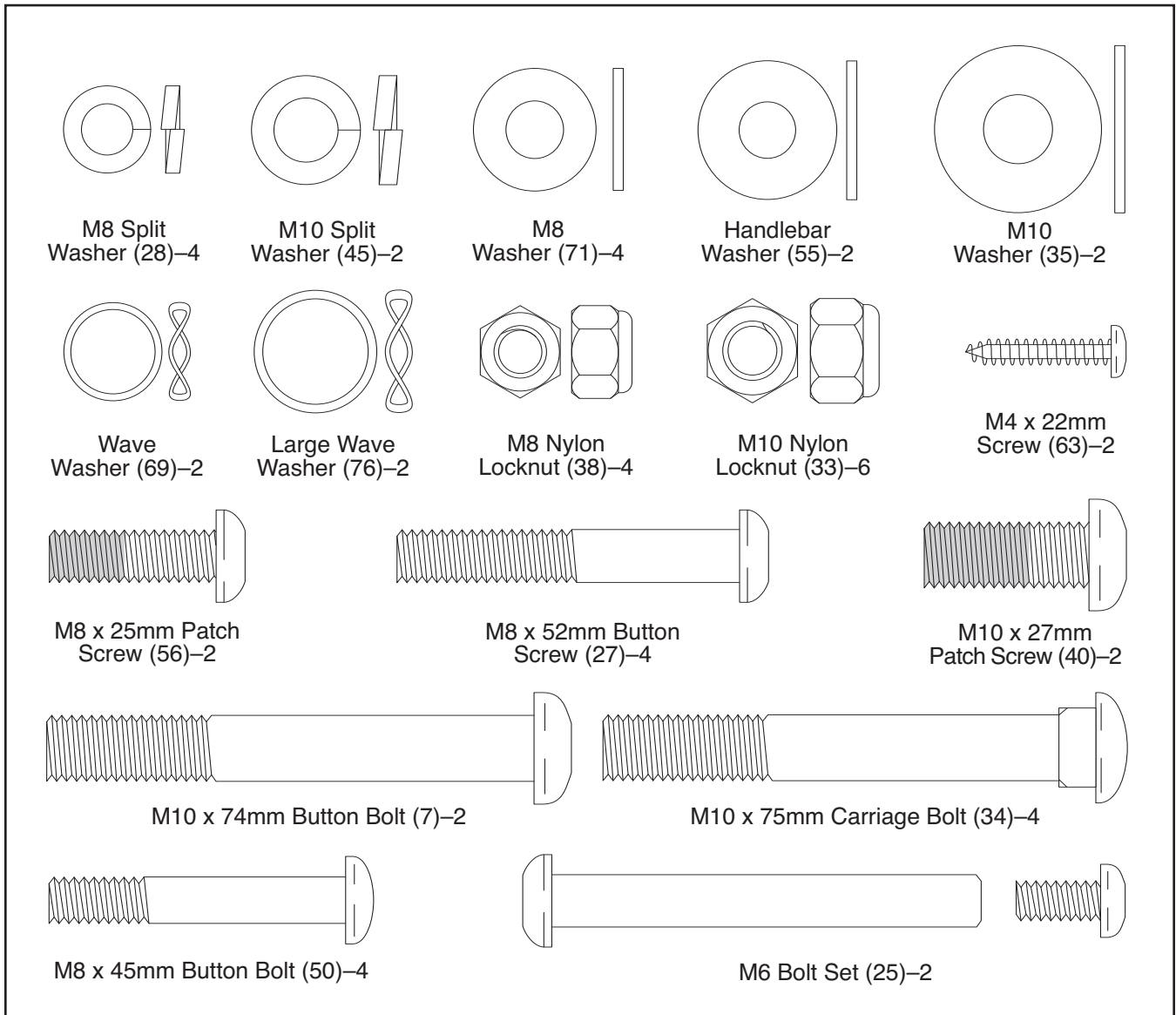

1. Identify the Stabilizer (9) which has round Endcaps (21) on the ends. While another person lifts the front of the Frame (1), attach the Stabilizer to the Frame with two M10 x 75mm Carriage Bolts (34) and two M10 Nylon Locknuts (33).

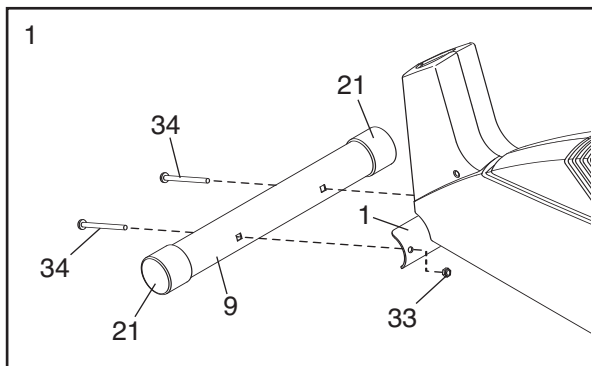

2. While another person lifts the back of the Frame (1), attach the other Stabilizer (9) to the Frame with two M10 x 75mm Carriage Bolts (34) and two M10 Nylon Locknuts (33).

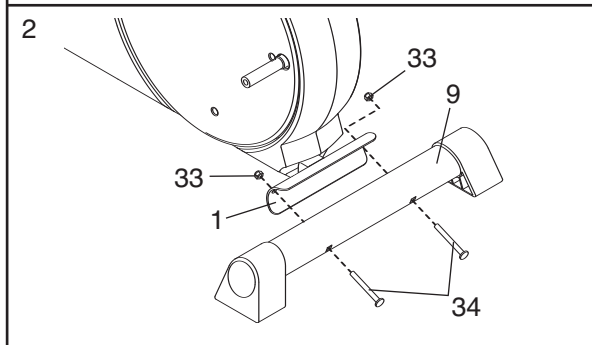

3. The Console (23) requires four 1.5V "D" batteries (not included); alkaline batteries are recommended. Remove the battery cover from the Console, and insert four batteries into the Console. **Make sure that the batteries are oriented as shown by the markings on the battery cover.** Then, reattach the battery cover.

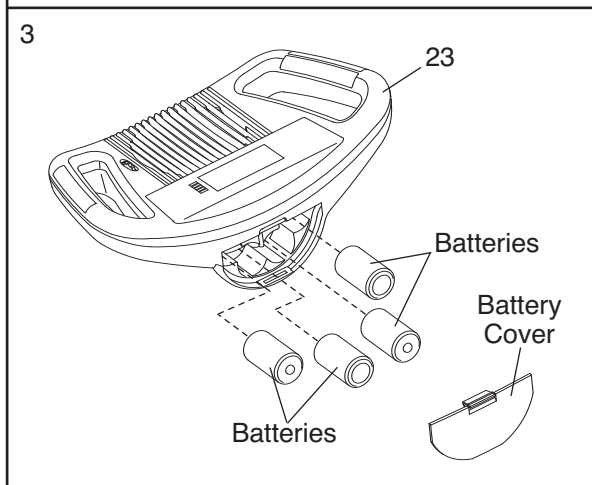

4. While another person holds the Console (23) in the position shown, connect the console wire to the Extension Wire (68).

Attach the Console (23) to the Upright (2) with the four Console Screws (59) included with the Console. **Be careful to avoid pinching the wires.**

Attach the Water Bottle Holder (29) to the Upright (2) with two M4 x 22mm Screws (63).

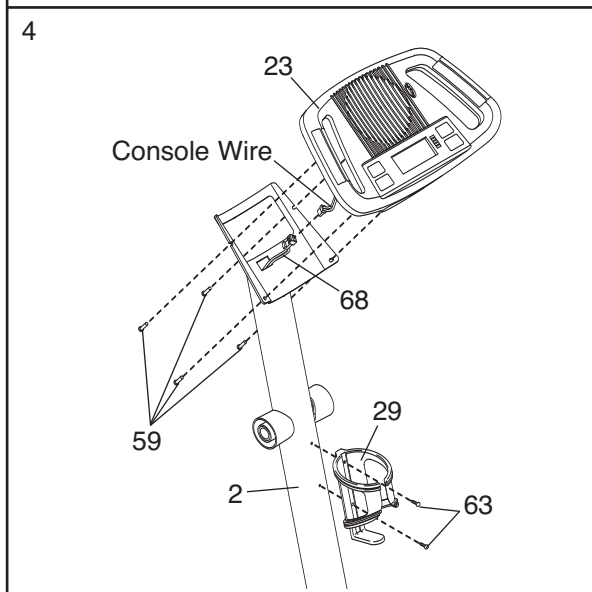

5. While another person holds the Upright (2) in the position shown, connect the Extension Wire (68) to the Lower Wire Harness (73).

Push the Extension Wire (68) and the Lower Wire Harness (73) down into the Frame (1). Slide the Upright (2) onto the Frame. **Be careful to avoid pinching the Wires.** Attach the Upright with two M10 x 74mm Button Bolts (7), two M10 Split Washers (45), and two M10 Nylon Locknuts (33). **Do not tighten the Button Bolts yet.**

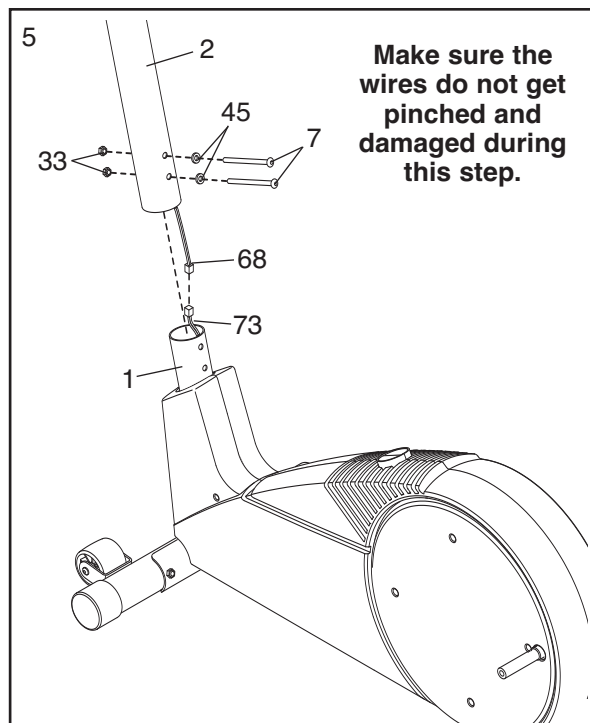

6. Identify the Left Handlebar (6), which is marked with a sticker. Insert the Left Handlebar into one of the Handlebar Legs (5); **make sure that the Handlebar Leg is turned so the hexagonal holes are on the indicated side.** Attach the Left Handlebar to the Handlebar Leg with two M8 x 45mm Button Bolts (50) and two M8 Nylon Locknuts (38). **Make sure that the Nylon Locknuts are inside the hexagonal holes.** **Do not tighten the Button Bolts yet.**

Insert the Pivot Axle (26) into the Upright (2), and center the Pivot Axle. Apply a generous amount of the included grease to both ends of the Pivot Axle.

Turn a Handlebar Spacer (47) so that the small arrow on the Handlebar Spacer is pointing toward the floor, and slide the Handlebar Spacer onto the post on the Left Handlebar (6). Next, slide the Left Handlebar onto the Pivot Axle (26).

Slide a Handlebar Washer (55) and a Wave Washer (69) onto an M8 x 25mm Patch Screw (56), and tighten the Patch Screw into the Pivot Axle (26). Then, press the tabs on a Handlebar Cap (46) into the Handlebar Spacer (47).

Assemble the Right Handlebar (8) and the other Handlebar Leg (5) in the same way.

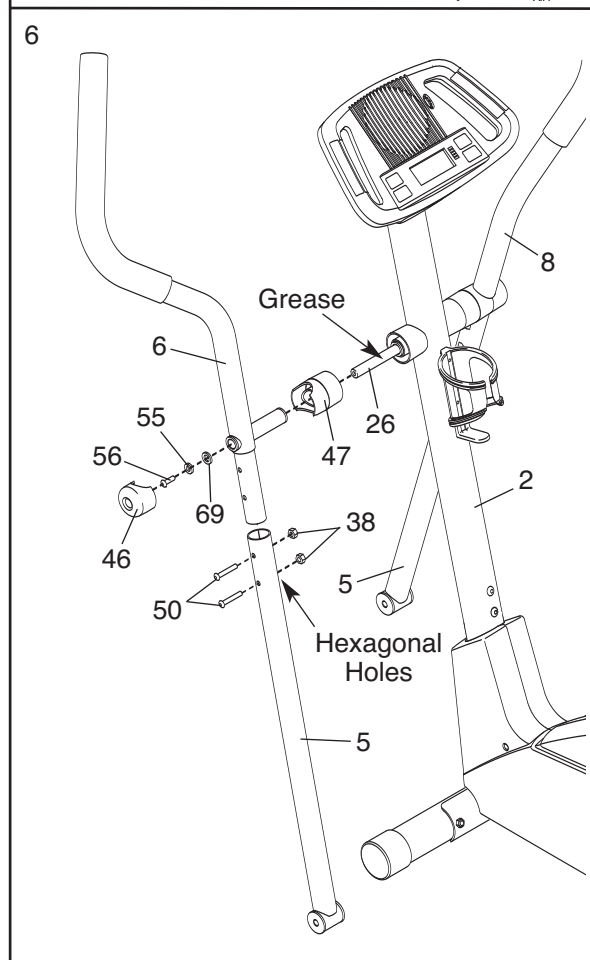

- Identify the Left Pedal Leg (11), which is marked with a sticker. Attach the Left Pedal (13) to the Left Pedal Leg with two M8 x 52mm Button Screws (27), two M8 Split Washers (28), and two M8 Washers (71).

Attach the Right Pedal (not shown) in the same way.

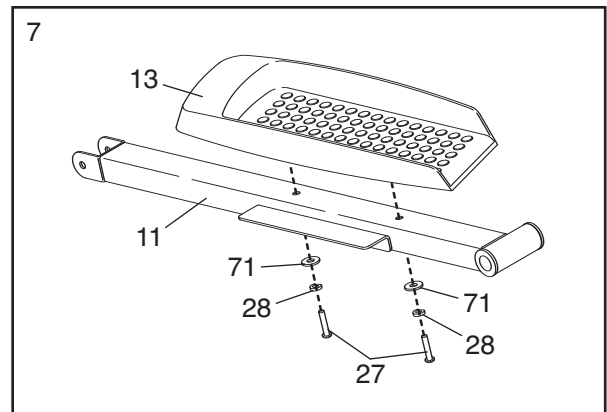

- Apply a small amount of grease to the axle on the left Disc Crossbar (16).

Slide the Left Pedal Leg (11) onto the axle on the left Disc Crossbar (16). Apply a small amount of grease to a Large Wave Washer (76) and press it onto the end of the Left Pedal Leg. Next, slide an M10 Washer (35) onto an M10 x 27mm Patch Screw (40), and tighten the Patch Screw into the axle. Then, press a Pedal Leg Endcap (74) into the Left Pedal Leg.

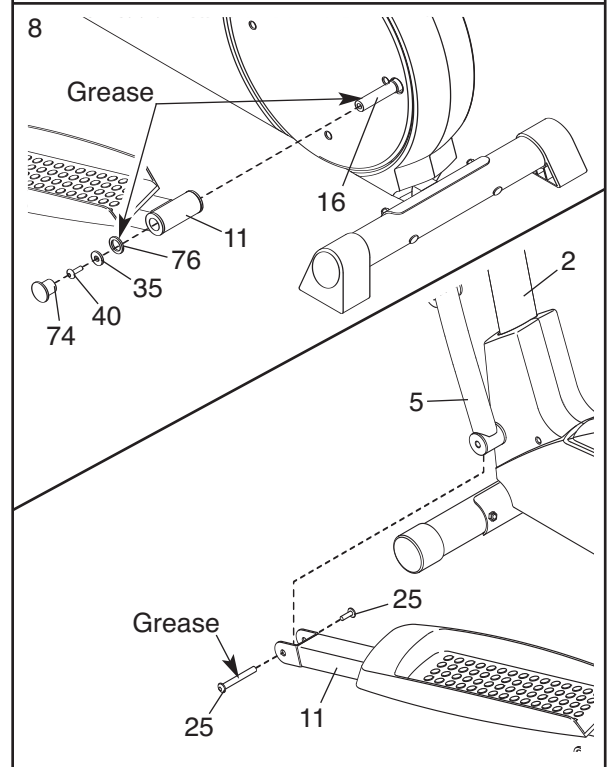

Hold the lower end of the left Handlebar Leg (5) inside of the bracket on the front of the Left Pedal Leg (11). Next, apply grease to an M6 Bolt Set (25). Attach the Handlebar Leg to the Left Pedal Leg with the Bolt Set. **Do not overtighten the Bolt Set; the Handlebar Leg must pivot freely.**

Attach the Right Pedal Leg (not shown) to the right side of the elliptical exerciser in the same way.

**See step 5.** Tighten the M10 x 74mm Button Bolts (7) in the Upright (2). **See step 6.** Tighten the M8 x 45mm Button Bolts (50) in the Handlebar Legs (5).

- Make sure that all parts of the elliptical exerciser are properly tightened.** Note: Some hardware may be left over after assembly is completed. To protect the floor or carpet from damage, place a mat under the elliptical exerciser.



# HOW TO USE THE ELLIPTICAL EXERCISER

## HOW TO EXERCISE ON THE ELLIPTICAL EXERCISER

To mount the elliptical exerciser, hold the handles on the console or the handlebars and step onto the pedal that is in the lowest position. Then, step onto the other pedal. Push the pedals until they begin to move with a continuous motion. **Note: The pedal disks can turn in either direction. It is recommended that you move the pedal disks in the direction shown by the arrow; however, for variety, you can turn the pedal disks in the opposite direction.**

To dismount the elliptical exerciser, wait until the pedals come to a complete stop. **Note: The elliptical exerciser does not have a free wheel; the pedals will continue to move until the flywheel stops.** When the pedals are stationary, step off the highest pedal first. Then, step off the lowest pedal.

The handlebars are designed to add upper-body exercise to your workouts. As you exercise, push and pull the handlebars to work your arms, shoulders, and back.

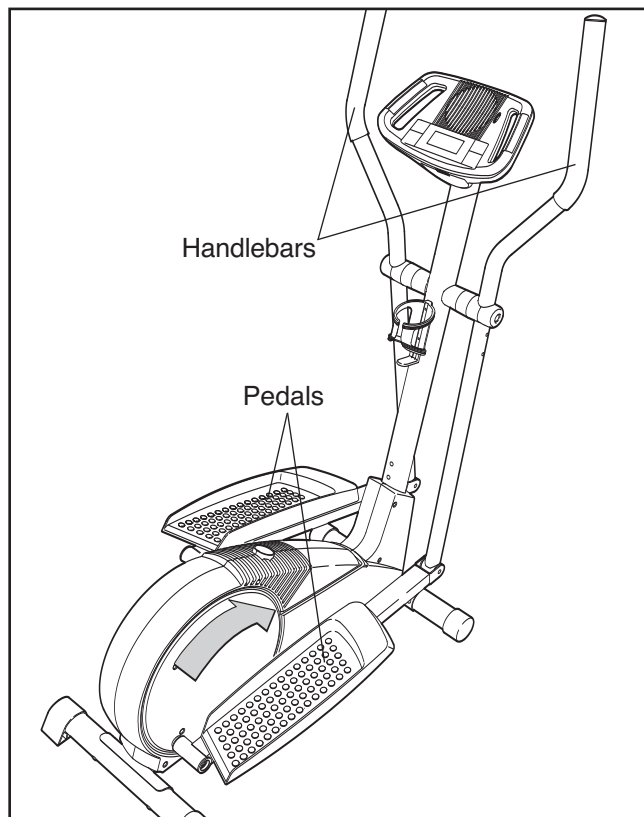

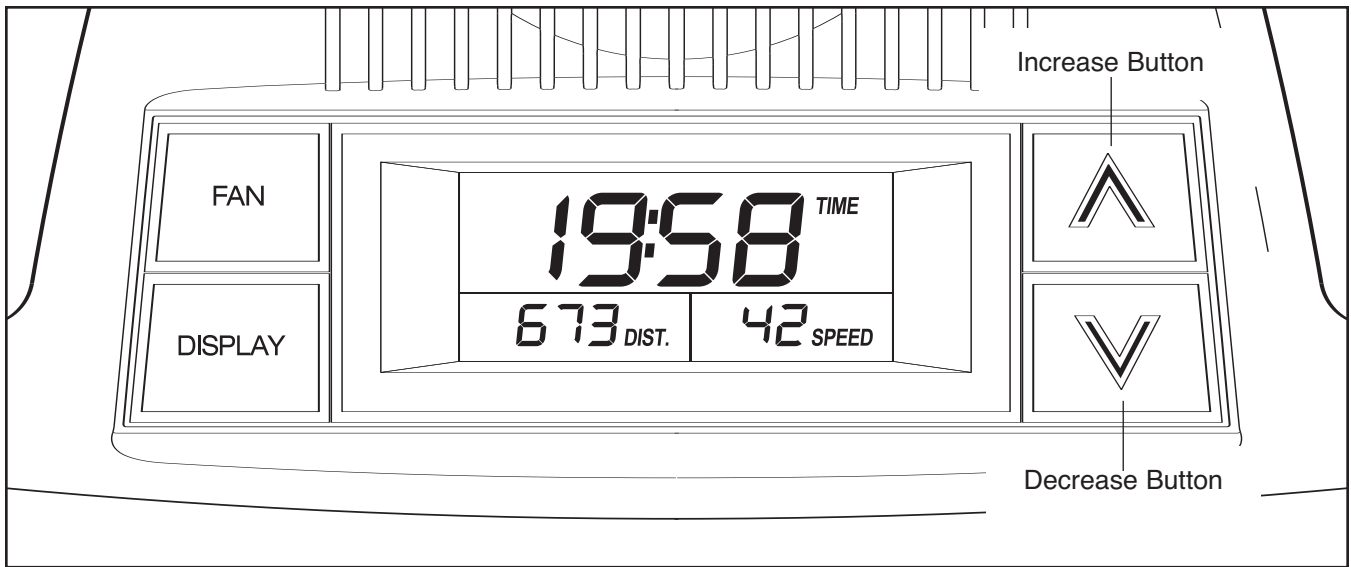

## HOW TO USE THE CONSOLE

### 1 Turn on the console.

Note: The console requires four 1.5V “D” batteries (see assembly step 3 on page 6). If there is a sheet of clear plastic on the face of the console, peel off the plastic.

To turn on the console, press the increase button or begin pedaling.

### 2 Change the resistance of the pedals as desired.

As you pedal, change the resistance of the pedals by pressing the increase or decrease button.

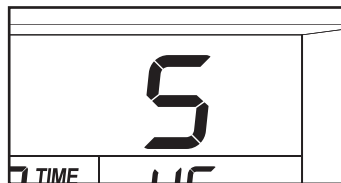

There are ten resistance levels. The selected resistance level will be shown in the upper display. Note: After a button is pressed, it will take a moment for the pedals to reach the selected resistance level.

### 3 Follow your progress with the displays.

As you exercise, the lower left display can show the elapsed time and the distance (total number of revolutions) that you have pedaled.



The lower right display can show your pedaling speed (in revolutions per minute) and the approximate number of calories you have burned. When you use the handgrip pulse sensor, the lower right display will also show your heart rate (see step 4 on page 11).

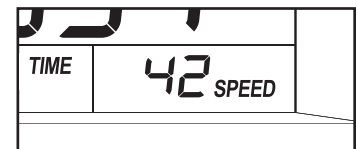

The upper display is the *priority display*. The priority display can show the elapsed time, the distance that

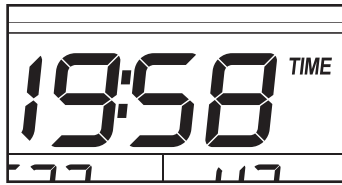

you have pedaled, your pedaling speed, or the approximate number of calories you have burned. Press the Display button repeatedly until the priority display shows the information that you are most interested in viewing. Note: While information is shown in the priority display, the information will not be shown in the lower left or right display.

#### 4 Measure your heart rate if desired.

**If there are sheets of clear plastic on the metal contacts on the handgrips, peel off the plastic.** To use the handgrip pulse sensor, hold the handgrips with your palms resting against the metal contacts.

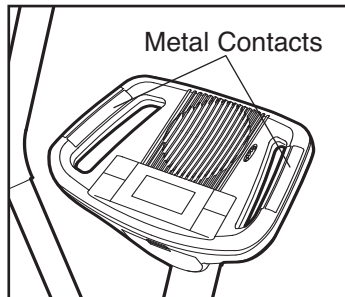

**Avoid moving your hands.** When your pulse is detected, the heart-shaped indicator in the lower right display will flash each time your heart beats. After a moment, your heart rate will be shown.

For the most accurate heart rate reading, continue to hold the handgrips for about 30 seconds. Note:

When you first hold the handgrips, the display will show your heart rate continuously for 30 seconds. The display will then show your heart rate along with other feedback modes.

#### 5 Turn on the fan if desired.

To turn on the fan at low speed, press the Fan button. To turn on the fan at high speed, press the button a second time. To turn off the fan, press the button a third time. Note: If the fan is left on and the pedals are not moved for thirty seconds, the fan will automatically turn off to conserve the batteries.

Rotate the thumb wheel on the right side of the console to pivot the fan to the desired angle.

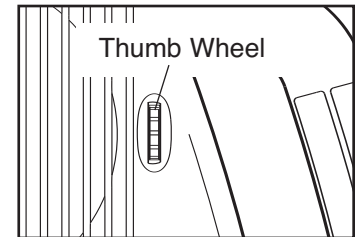

#### 6 When you are finished exercising, the console will automatically turn off.

If the pedals are not moved for a few seconds, the displays will pause and the priority display will flash. If the pedals are not moved and the console buttons are not pressed for a few minutes, the console will turn off to conserve the batteries.

# MAINTENANCE AND TROUBLESHOOTING

Inspect and tighten all parts of the elliptical exerciser regularly. Replace any worn parts immediately.

To clean the elliptical exerciser, use a damp cloth and a small amount of mild dish soap. **Important: Keep liquids away from the console and keep the console out of direct sunlight. During storage, remove the batteries from the console.**

## BATTERY REPLACEMENT

If the console display becomes dim, the batteries should be replaced. See assembly step 3 on page 6 for replacement instructions.

## HOW TO ADJUST THE REED SWITCH

If the console does not display correct feedback, the reed switch should be adjusted. To adjust the reed switch, you must first remove the Right Pedal Leg (12), the right Pedal Disc (15), and the Side Shields (3, 4). See step 8 on page 8 and remove the Right Pedal Leg.

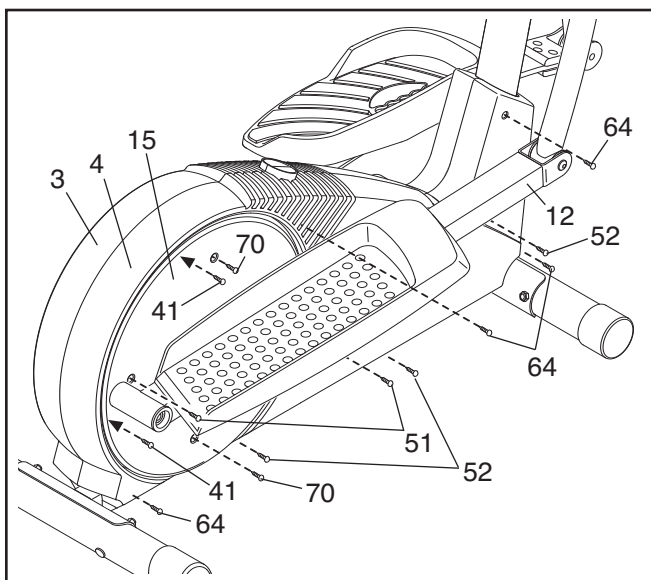

Next, remove the four Screws (51, 70) from the right Pedal Disc (15), and slide the Pedal Disc off. Remove all Screws (52, 64) from the Right Side Shield (4) and the two Bolts (41) from beneath the Pedal Disc, and remove the Right Side Shield (4). Remove all Screws (52) from the Left Side Shield (3), and move the Left Side Shield.

Next, see the drawing below and locate the Reed Switch (53). Loosen, but do not remove, the indicated M4 x 16mm Self-tapping Screw (52). Slide the Reed Switch slightly toward or away from the Magnet (58) on the flywheel. Retighten the Screw. Turn the left Pedal Disc (15) for a moment. Repeat until the console displays correct feedback. When the Reed Switch is correctly adjusted, reattach the Side Shields (3, 4), the right Pedal Disc (15), and the Right Pedal Leg (12).

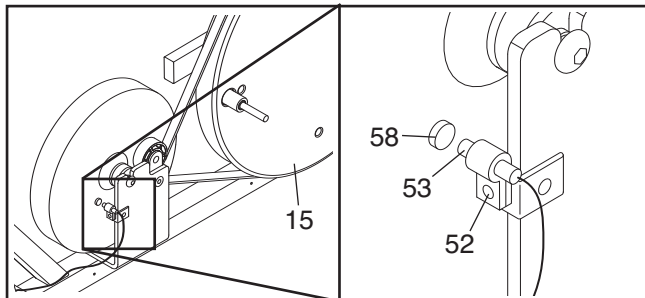

## HOW TO ADJUST THE DRIVE BELT

If you can feel the pedals slip while you are pedaling, even when the resistance is adjusted to the highest level, the Drive Belt (19) may need to be adjusted. To adjust the Drive Belt, you must first remove both side shields. See HOW TO ADJUST THE REED SWITCH at the left and remove the side shields.

Next, loosen the M8 x 22mm Flat Head Screw (65) and turn the M10 x 60mm Button Bolt (62) until the Drive Belt (19) is tight. When the Drive Belt is tight, tighten the Flat Head Screw. Then, reattach the side shields.

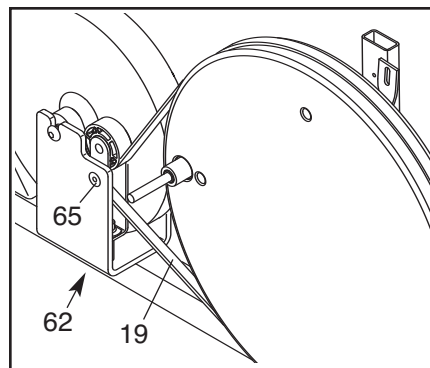

# CONDITIONING GUIDELINES

## WARNING:



Before beginning this or any exercise program, consult your physician. This is especially important for persons over the age of 35 or persons with pre-existing health problems.

The pulse sensor is not a medical device. Various factors, including the user's movement, may affect the accuracy of heart rate readings. The pulse sensor is intended only as an exercise aid in determining heart rate trends in general.

The following guidelines will help you to plan your exercise program. Remember that proper nutrition and adequate rest are essential for successful results.

### EXERCISE INTENSITY

Whether your goal is to burn fat or to strengthen your cardiovascular system, the key to achieving the desired results is to exercise with the proper intensity. The proper intensity level can be found by using your heart rate as a guide. The chart below shows recommended heart rates for fat burning, maximum fat burning, and cardiovascular (aerobic) exercise.

165	155	145	140	130	125	115	
145	138	130	125	118	110	103	
125	120	115	110	105	95	90	
20	30	40	50	60	70	80	

To find the proper heart rate for you, first find your age at the bottom of the chart (ages are rounded off to the nearest ten years). Next, find the three numbers above your age. The three numbers are your “training zone.” The lower two numbers are recommended heart rates for fat burning; the highest number is the recommended heart rate for aerobic exercise.

### Fat Burning

To burn fat effectively, you must exercise at a relatively low intensity level for a sustained period of time.

During the first few minutes of exercise, your body uses easily accessible *carbohydrate* calories for energy. Only after the first few minutes of exercise does your body begin to use stored *fat* calories for energy. If your goal is to burn fat, adjust the intensity of your exercise until your heart rate is near the lowest number in your training zone as you exercise.

For maximum fat burning, adjust the intensity of your exercise until your heart rate is near the middle number in your training zone as you exercise.

### Aerobic Exercise

If your goal is to strengthen your cardiovascular system, your exercise must be “aerobic.” Aerobic exercise is activity that requires large amounts of oxygen for prolonged periods of time. This increases the demand on the heart to pump blood to the muscles, and on the lungs to oxygenate the blood. For aerobic exercise, adjust the intensity of your exercise until your heart rate is near the highest number in your training zone as you exercise.

### WORKOUT GUIDELINES

Each workout should include the following three parts:

**A warm-up**, consisting of 5 to 10 minutes of stretching and light exercise. A proper warm-up increases your body temperature, heart rate, and circulation in preparation for exercise.

**Training zone exercise**, consisting of 20 to 30 minutes of exercising with your heart rate in your training zone. (During the first few weeks of your exercise program, do not keep your heart rate in your training zone for longer than 20 minutes.)

**A cool-down**, with 5 to 10 minutes of stretching. This will increase the flexibility of your muscles and will help to prevent post-exercise problems.

### EXERCISE FREQUENCY

To maintain or improve your condition, complete three workouts each week, with at least one day of rest between workouts. After a few months of regular exercise, you may complete up to five workouts each week if desired. The key to success is to make exercise a regular and enjoyable part of your everyday life.

# PART LIST—Model No. PFEL2926.0

R0606A

Key No.	Qty.	Description	Key No.	Qty.	Description
1	1	Frame	41	2	M6 x 18mm Bolt
2	1	Upright	42	6	M5 x16mm Screw
3	1	Left Side Shield	43	4	M5 Washer
4	1	Right Side Shield	44	2	Handlebar Endcap
5	2	Handlebar Leg	45	2	M10 Split Washer
6	1	Left Handlebar	46	2	Handlebar Cap
7	2	M10 x 74mm Button Bolt	47	2	Handlebar Spacer
8	1	Right Handlebar	48	2	Frame Spacer
9	2	Stabilizer	49	6	Small Handlebar Bushing
10	2	M5 Nylon Locknut	50	4	M8 x 45mm Button Bolt
11	1	Left Pedal Leg	51	4	M6 x 25mm Screw
12	1	Right Pedal Leg	52	7	M4 x 16mm Self-tapping Screw
13	1	Left Pedal	53	1	Reed Switch/Wire
14	1	Right Pedal	54	1	Cable Clamp
15	2	Pedal Disc	55	2	Handlebar Washer
16	2	Disc Crossbar	56	2	M8 x 25mm Patch Screw
17	1	Flywheel	57	1	Flywheel Axle
18	1	Side Shield Bracket	58	1	Magnet
19	1	Drive Belt	59	4	Console Screw
20	2	Rear Endcap	60	4	Large Handlebar Leg Bushing
21	2	Front Endcap	61	2	5/16" x 25.4mm Hex Bolt
22	1	Belt Idler	62	1	M10 x 60mm Button Bolt
23	1	Console	63	2	M4 x 22mm Screw
24	2	Handgrip	64	4	M4 x 25mm Screw
25	2	M6 Bolt Set	65	1	M8 x 22mm Flat Head Screw
26	1	Pivot Axle	66	2	M6 Nylon Locknut
27	4	M8 x 52mm Button Screw	67	2	M5 x 14mm Self-tapping Screw
28	4	M8 Split Washer	68	1	Extension Wire
29	1	Water Bottle Holder	69	2	Wave Washer
30	2	Large Snap Ring	70	4	M6 x 28mm Screw
31	2	Large Bearing	71	4	M8 Washer
32	1	Pedal Axle	72	1	Resistance Motor
33	7	M10 Nylon Locknut	73	1	Lower Wire Harness
34	4	M10 x 75mm Carriage Bolt	74	2	Pedal Leg Endcap
35	4	M10 Washer	75	1	Upright Endcap
36	2	M3 x 16mm Screw	76	2	Large Wave Washer
37	2	Pedal Arm Bushing	#	2	Hex Key
38	5	M8 Nylon Locknut	#	1	Grease
39	2	Inside Pedal Arm Bushing	#	1	User's Manual
40	2	M10 x 27mm Patch Screw			

Note: # indicates a non-illustrated part. Specifications are subject to change without notice.



# EXPLODED DRAWING—Model No. PFEL2926.0

R0606A

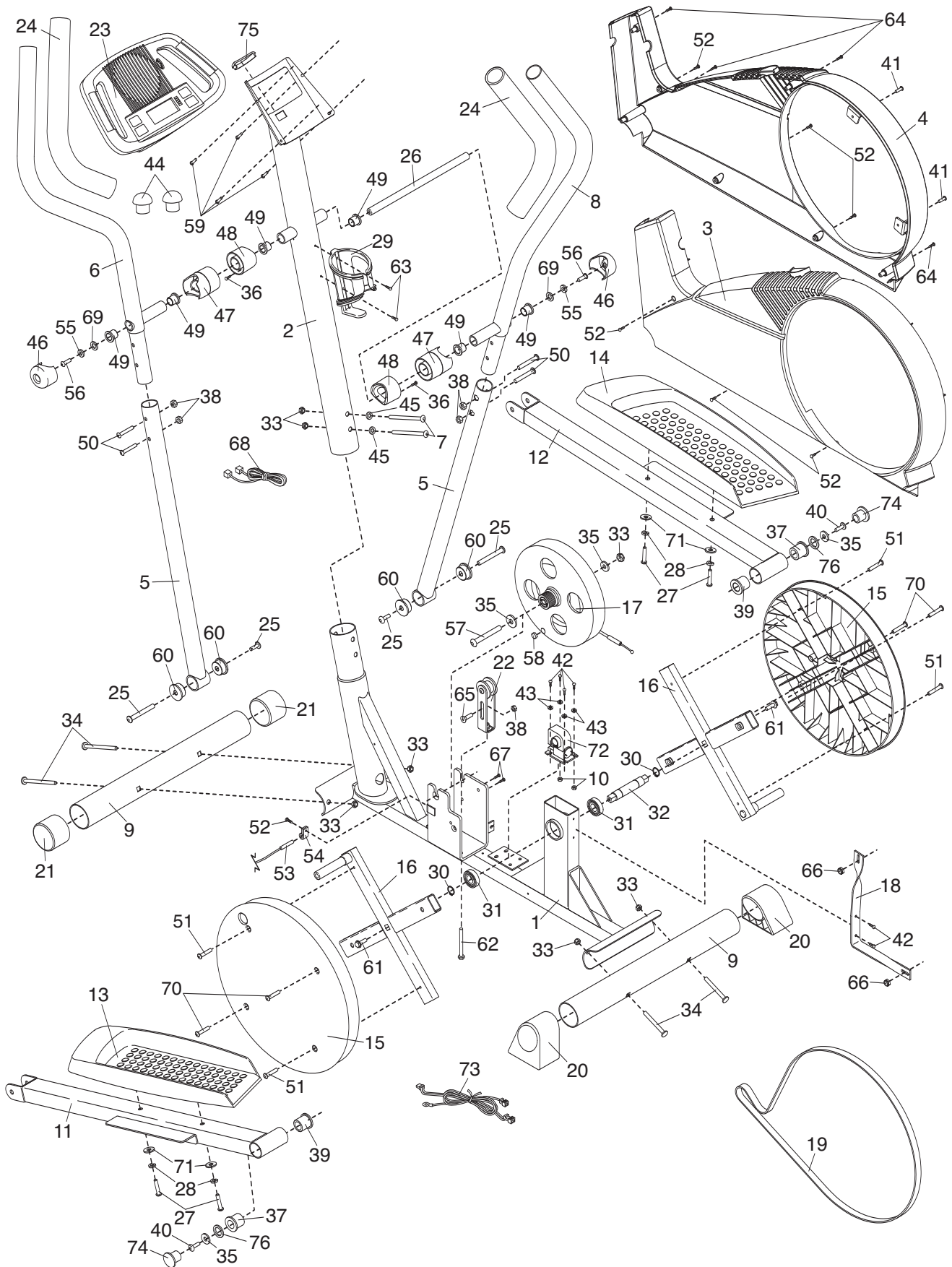

---

# HOW TO ORDER REPLACEMENT PARTS

To order replacement parts, please see the front cover of this manual. To help us assist you, please be prepared to provide the following information when contacting us:

- the MODEL NUMBER of the product (PFEL2926.0)
- the NAME of the product (PROFORM 320 elliptical exerciser)
- the SERIAL NUMBER of the product (see the front cover of this manual)
- the KEY NUMBER and DESCRIPTION of the part(s) (see page 14)

## LIMITED WARRANTY

ICON Health & Fitness, Inc. (ICON), warrants this product to be free from defects in workmanship and material, under normal use and service conditions, for a period of ninety (90) days from the date of purchase. This warranty extends only to the original purchaser. ICON's obligation under this warranty is limited to replacing or repairing, at ICON's option, the product through one of its authorized service centers. All repairs for which warranty claims are made must be pre-authorized by ICON. If the product is shipped to a service center, freight charges to and from the service center will be the customer's responsibility. For in-home service, the customer will be responsible for a minimal trip charge. This warranty does not extend to any product or damage to a product caused by or attributable to freight damage, abuse, misuse, improper or abnormal usage or repairs not provided by an ICON authorized service center; products used for commercial or rental purposes; or products used as store display models. No other warranty beyond that specifically set forth above is authorized by ICON.

ICON is not responsible or liable for indirect, special or consequential damages arising out of or in connection with the use or performance of the product or damages with respect to any economic loss, loss of property, loss of revenues or profits, loss of enjoyment or use, costs of removal or installation or other consequential damages of whatsoever nature. Some states do not allow the exclusion or limitation of incidental or consequential damages. Accordingly, the above limitation may not apply to you.

The warranty extended hereunder is in lieu of any and all other warranties and any implied warranties of merchantability or fitness for a particular purpose is limited in its scope and duration to the terms set forth herein. Some states do not allow limitations on how long an implied warranty lasts. Accordingly, the above limitation may not apply to you.

This warranty gives you specific legal rights. You may also have other rights which vary from state to state.

**ICON HEALTH & FITNESS, INC., 1500 S. 1000 W., LOGAN, UT 84321-9813**