

PRO-FORM®

StrideClimber 650

Model No. PFEL05807.0

Serial No. _____

Write the serial number in the space above for future reference.

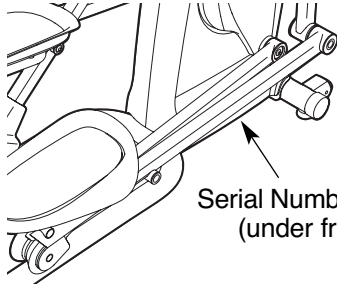

Serial Number Decal
(under frame)

USER'S MANUAL

QUESTIONS?

As a manufacturer, we are committed to providing complete customer satisfaction. If you have questions, or if parts are damaged or missing, **PLEASE DO NOT CONTACT THE STORE; please contact Customer Care.**

IMPORTANT: You must note the product model number and serial number (see the drawing above) before contacting us:

CALL TOLL-FREE:

1-888-533-1333

Mon.-Fri. 6 a.m.-6 p.m. MST

Sat. 8 a.m.-4 p.m. MST

ON THE WEB:

www.proformservice.com

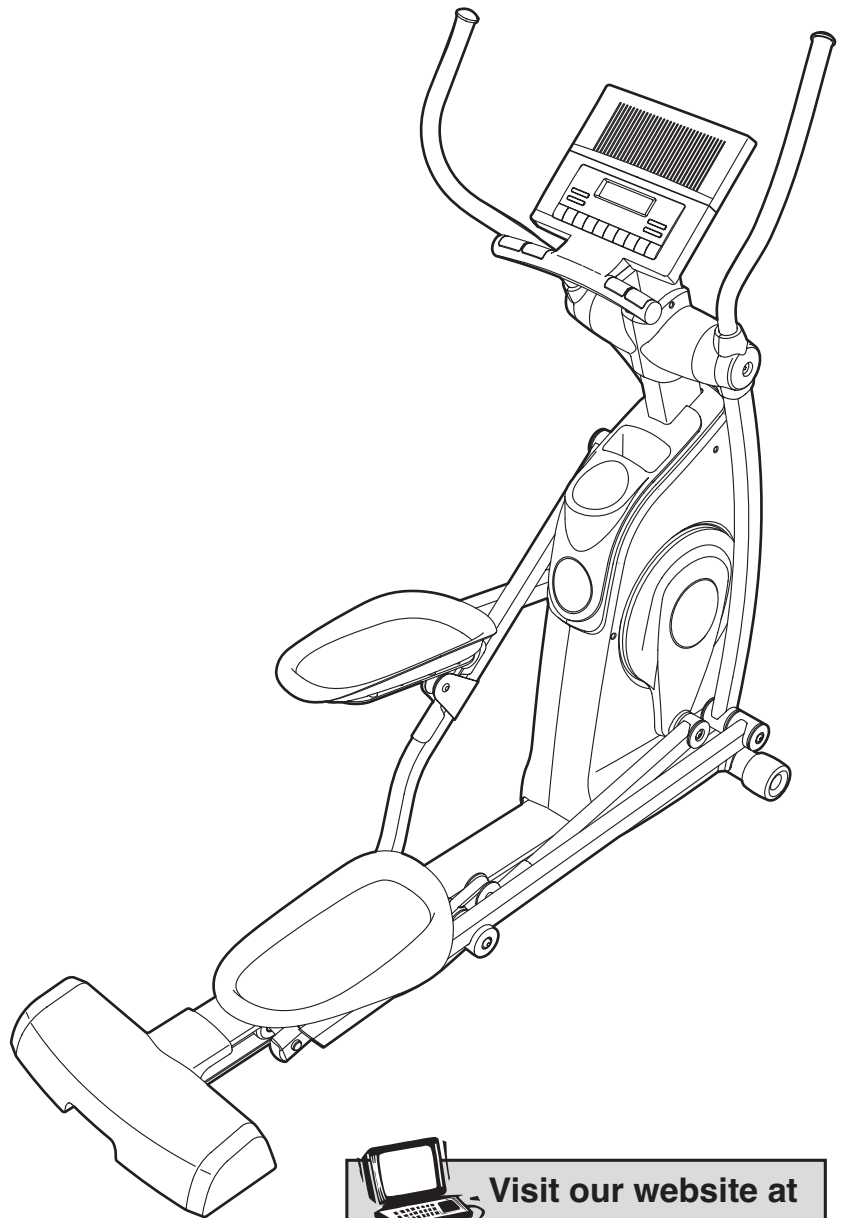

CAUTION

Read all precautions and instructions in this manual before using this equipment. Keep this manual for future reference.



Visit our website at

www.proform.com

new products, prizes,
fitness tips, and much more!

TABLE OF CONTENTS

WARNING DECAL PLACEMENT2
IMPORTANT PRECAUTIONS3
BEFORE YOU BEGIN4
ASSEMBLY5
HOW TO USE THE ELLIPTICAL EXERCISER13
MAINTENANCE AND TROUBLESHOOTING20
EXERCISE GUIDELINES21
PART LIST23
EXPLODED DRAWING25
ORDERING REPLACEMENT PARTSBack Cover
LIMITED WARRANTYBack Cover

WARNING DECAL PLACEMENT

The warning decal shown here has been applied in the location shown. **If the decal is missing or illegible, call the telephone number on the front cover of this manual and request a free replacement decal. Apply the decal in the location shown.**
Note: The decal may not be shown at actual size.

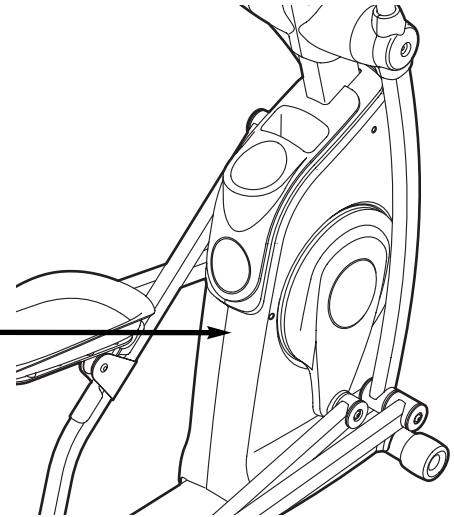
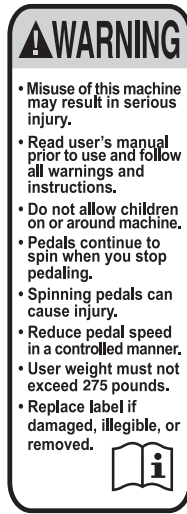

IMPORTANT PRECAUTIONS

⚠️ WARNING: To reduce the risk of serious injury, read all important precautions and instructions in this manual and all warnings on your elliptical exerciser before using your elliptical exerciser. ICON assumes no responsibility for personal injury or property damage sustained by or through the use of this product.

1. Before beginning any exercise program, consult your physician. This is especially important for persons over the age of 35 or persons with pre-existing health problems.
2. It is the responsibility of the owner to ensure that all users of the elliptical exerciser are adequately informed of all precautions.
3. Your elliptical exerciser is intended for home use only. Do not use your elliptical exerciser in a commercial, rental, or institutional setting.
4. Keep your elliptical exerciser indoors, away from moisture and dust. Place your elliptical exerciser on a level surface, with a mat beneath it to protect the floor or carpet. Make sure that there is enough clearance around your elliptical exerciser to mount, dismount, and use it.
5. Inspect and properly tighten all parts regularly. Replace any worn parts immediately.
6. Keep children under age 12 and pets away from your elliptical exerciser at all times.
7. Your elliptical exerciser should not be used by persons weighing more than 275 lbs. (124 kg).
8. Wear appropriate exercise clothes when exercising; do not wear loose clothes that could become caught on your elliptical exerciser. Always wear athletic shoes for foot protection.
9. Hold the handgrip pulse sensor or the handlebars when mounting, dismounting, or using your elliptical exerciser.
10. Keep your back straight while using your elliptical exerciser; do not arch your back.
11. The pulse sensor is not a medical device. Various factors, including the user's movement, may affect the accuracy of heart rate readings. The pulse sensor is intended only as an exercise aid in determining heart rate trends in general.
12. When you stop exercising, allow the pedals to slowly come to a stop.
13. If you feel pain or dizziness while exercising, stop immediately and cool down.
14. Use your elliptical exerciser only as described in this manual.

BEFORE YOU BEGIN

Thank you for selecting the revolutionary PROFORM® STRIDECLIMBER 650 elliptical exerciser. The PROFORM STRIDECLIMBER 650 elliptical exerciser provides a wide array of features designed to make your workouts at home more effective and enjoyable.

For your benefit, read this manual carefully before you use the elliptical exerciser. If you have questions after reading this manual, please see the front cover of this manual. To help us assist you, note the product model number and serial number before con-

tacting us. The model number and the location of the serial number decal are shown on the front cover of this manual.

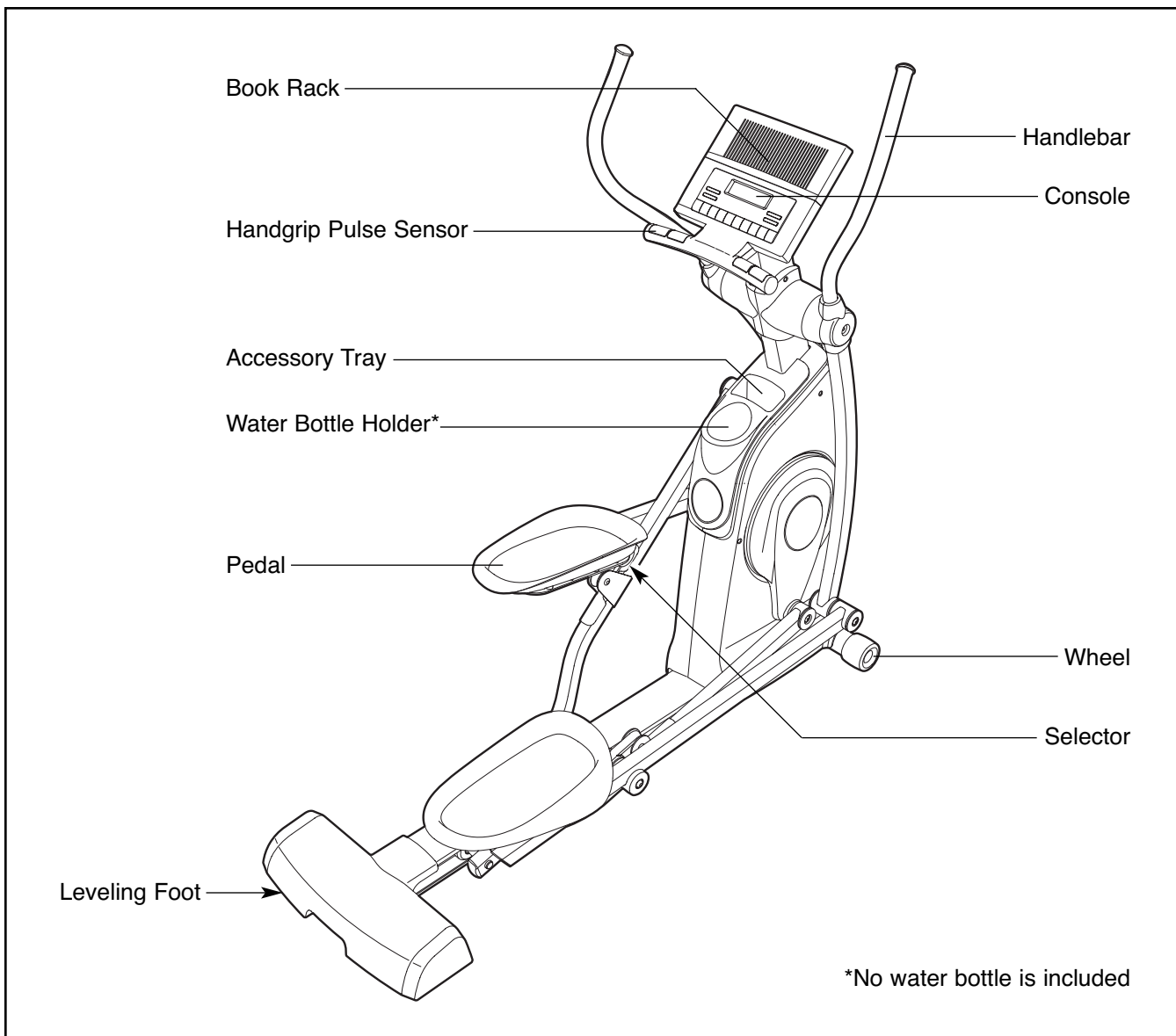

To avoid a registration fee for any service needed under warranty, you must register the elliptical exerciser at www.proformservice.com/registration.

Before reading further, please familiarize yourself with the parts that are labeled in the drawing below.



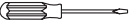

ASSEMBLY

To hire an authorized service technician to assemble the elliptical exerciser, call 1-800-445-2480.

Assembly requires two persons. Place all parts of the elliptical exerciser in a cleared area and remove the packing materials. Do not dispose of the packing materials until assembly is completed. **In addition to the included tools, assembly requires a Phillips screwdriver** , **an adjustable wrench** , and **a rubber mallet** .

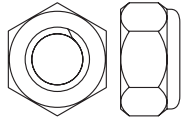
As you assemble the elliptical exerciser, use the drawings below to identify small parts. The number in parentheses below each drawing is the key number of the part, from the PART LIST near the end of this manual. The number following the parentheses is the quantity needed for assembly. **IMPORTANT: Some small parts may have been preassembled. If a part is not in the hardware kit, check to see if it has been preassembled.**

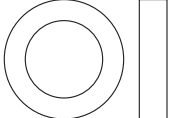
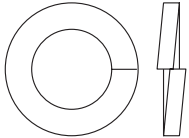
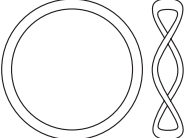
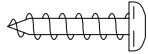
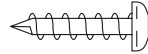
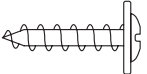
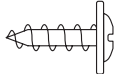
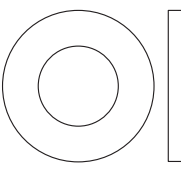
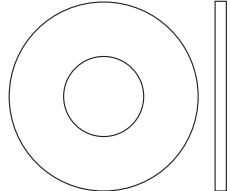
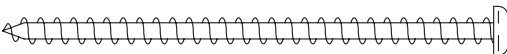
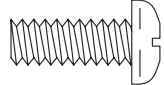
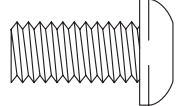
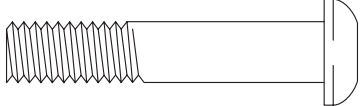
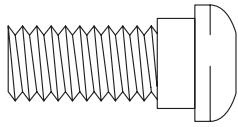
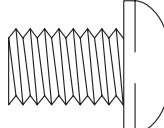
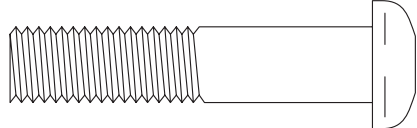
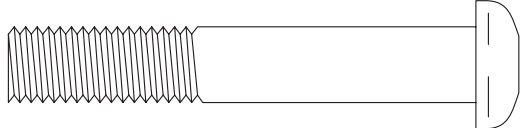
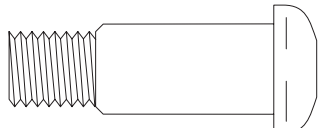
				
M8 Nylon Locknut (96)–4	M6 Split Washer (88)–8	M10 Spacer (76)–2	M10 Split Washer (72)–2	Wave Washer (93)–6
				
M4 x 16mm Screw (86)–4	M4 x 16mm Self-tapping Screw (79)–10	M4 x 16mm Flange Screw (84)–2	M4 x 12mm Flange Screw (73)–6	
				
M4 x 65mm Screw (91)–4				
				
M6 x 16mm Phillips Screw (87)–8	M8 x 16mm Button Screw (95)–3	M8 x 42mm Button Bolt (71)–4	M10 x 23mm Shoulder Screw (80)–8	
				
M10 x 15mm Patch Screw (82)–4	M10 x 48mm Button Screw (78)–2	M10 x 62mm Button Bolt (97)–2		
				
M10 x 35mm Shoulder Screw (94)–2				

1. **To make assembly easier, read the information on page 5 before you begin assembling the elliptical exerciser.**

While a second person tips the Frame (2) backward, attach a Wheel (25) to each side of the Frame with an M10 x 35mm Shoulder Screw (94).

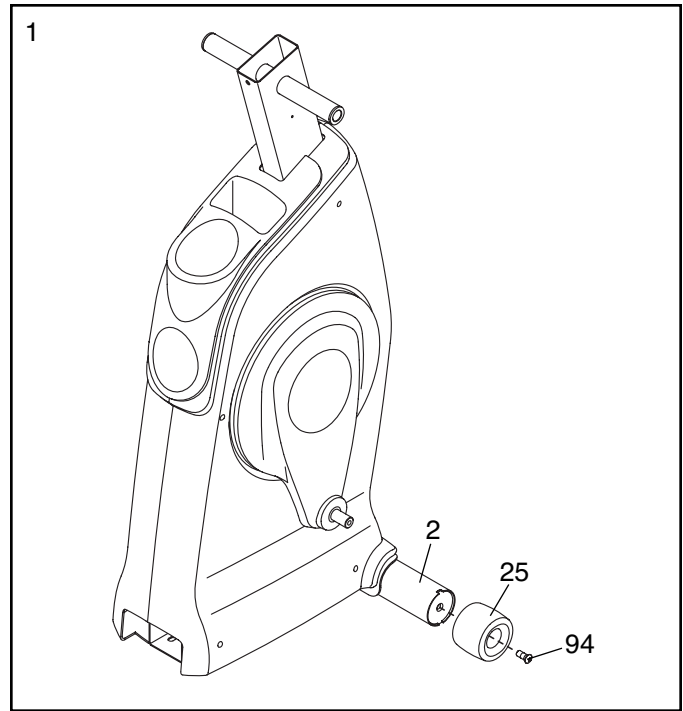

2. Carefully tip the Frame (2) onto its side. Orient the Base (1) as shown, and then insert the Base into the Frame. Attach the Base with two M10 x 62mm Button Bolts (97), two M10 Spacers (76), two M10 x 48mm Button Screws (78), and two M10 Split Washers (72).

Then, carefully tip the elliptical exerciser to an upright position.

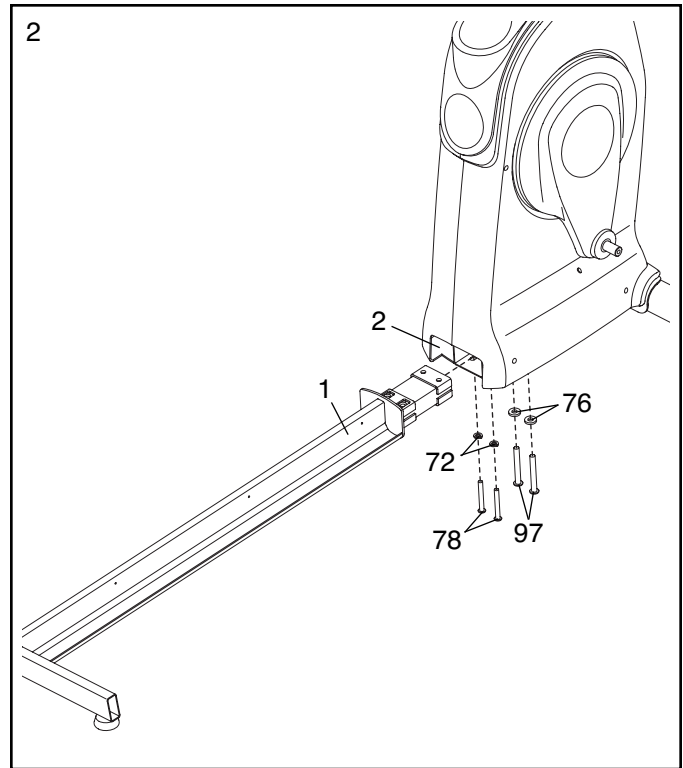

3. Identify the Right Roller Leg (21) and the Right Pedal Leg (16), which are marked with "R" stickers. Orient the Right Roller Leg and the Right Pedal Leg as shown.

Apply a small amount of the included grease to a Roller Axle (24). Attach the Selector (34), which is located on the Right Pedal Leg (16), to the Right Roller Leg with the Roller Axle, two M10 x 25mm x 1.5mm Washers (83), and two M10 x 15mm Patch Screws (82).

Repeat this step for the Left Roller Leg (not shown) and the Left Pedal Leg (not shown).

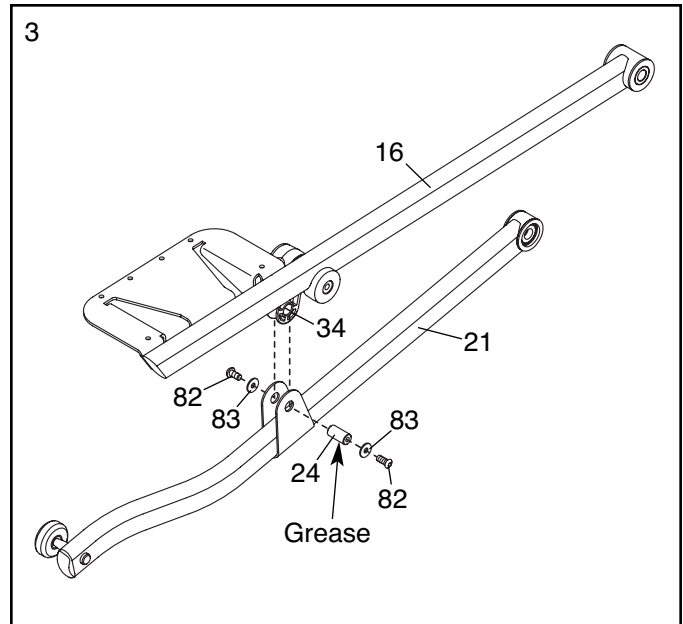

4. Identify the Right Pedal (15) and the Right Pedal Leg (16), which are marked with "R" stickers. Orient the Right Pedal and the Right Pedal Leg as shown. Attach the Right Pedal with four M6 x 16mm Phillips Screws (87) and four M6 Split Washers (88).

Repeat this step for the Left Pedal (not shown) and the Left Pedal Leg (not shown).

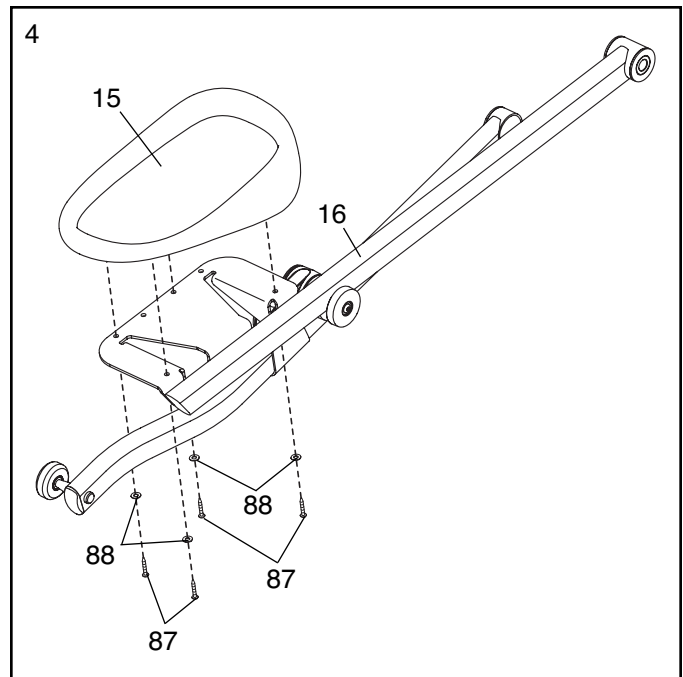

5. Apply a small amount of grease to the axle on the right Crank Arm (36) and to a Wave Washer (93). Then, slide the Wave Washer onto the Crank Arm.

Also, apply a small amount of white grease, which is marked with a "For Wheels" sticker, to the Roller (22) on the Right Roller Leg (21); spread the grease evenly around the Roller.

Slide the Right Roller Leg (21) onto the axle on the right Crank Arm (36) and set the Roller (22) on the Base (1). Attach the Right Roller Leg with an M10 x 23mm Shoulder Screw (80), an M10 x 20mm x 2mm Washer (81), and a Crank Axle Cap (30).

Repeat this step for the other side of the elliptical exerciser.

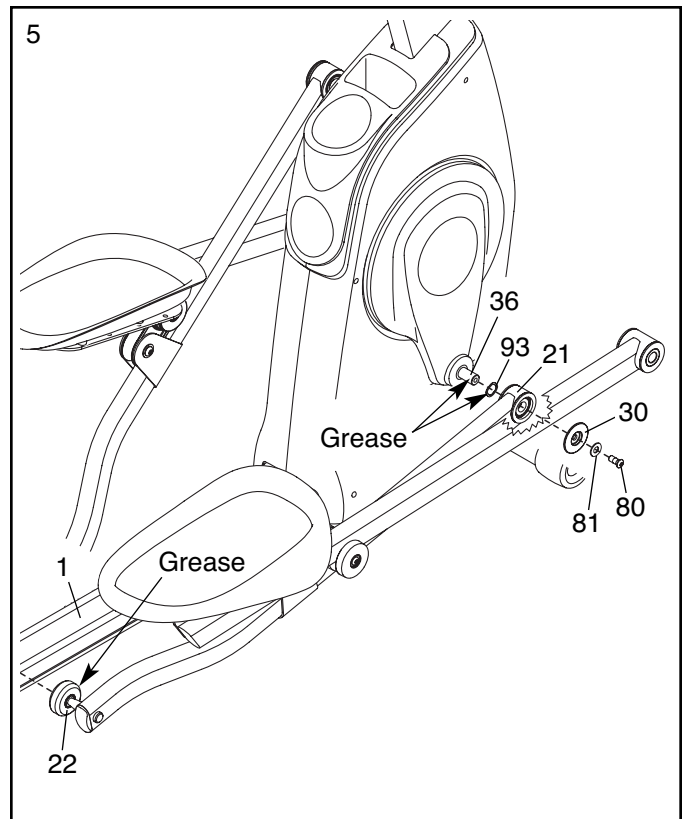

6. Attach the Center Frame Cover (27) to the Base (1) with six M4 x 12mm Flange Screws (73).

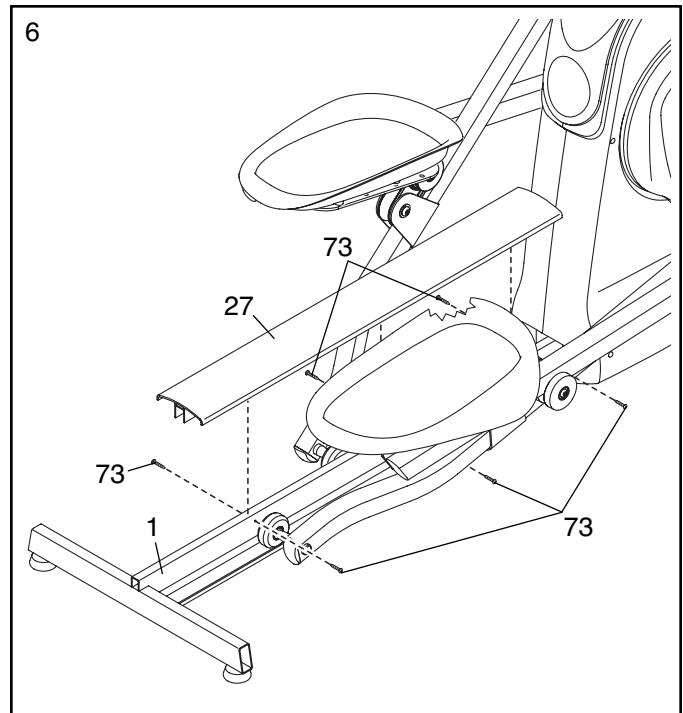

7. Orient the Rear Frame Cover (23) as shown. While a second person tips the elliptical exerciser forward, attach the Rear Frame Cover to the Base (1) with four M4 x 65mm Screws (91) and two M4 x 16mm Self-tapping Screws (79).

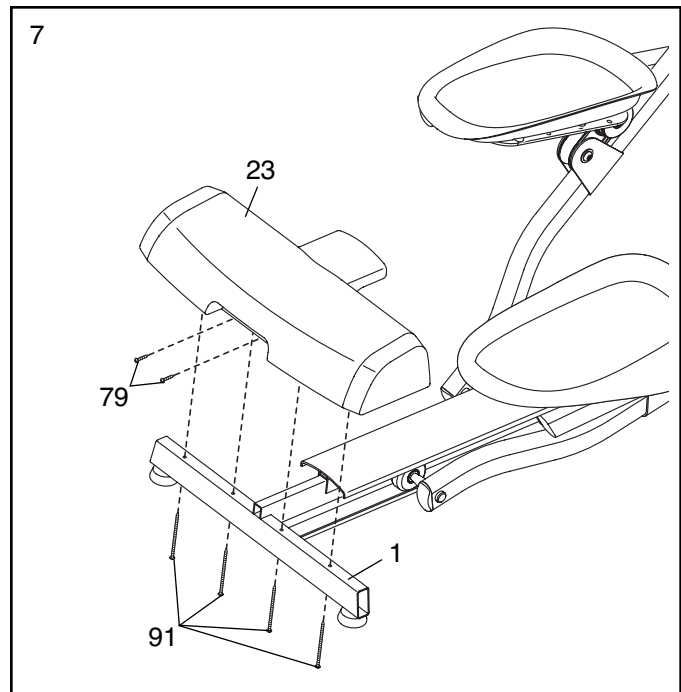

8. Have a second person hold the Upright (6) near the Frame (2) as shown.

Pull the Wire Harness (48) out of the Frame (2) and insert it upward through the Upright (6).

Tip: Use a piece of tape or an elastic band to hold the Wire Harness in place until step 14.

Insert the Upright (6) into the Frame (2).

Tip: Start all screws before tightening any of them. Attach the Upright with three M8 x 16mm Button Screws (95). **Avoid pinching the Wire Harness (48) between the Upright and the Frame.**

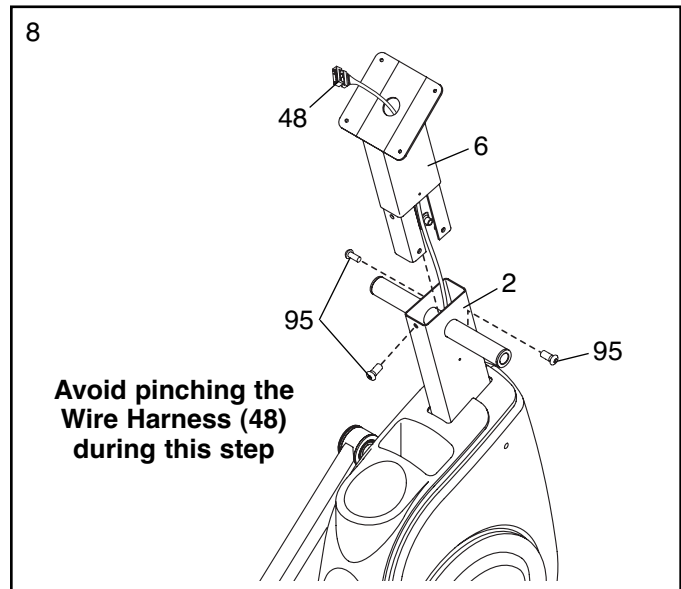

9. Apply a generous amount of grease to the Pivot Axle (65) and insert it into the Frame (2).

Orient the two Frame Covers (17) as shown. Attach the Frame Covers to the Frame (2) with four M4 x 16mm Screws (86).

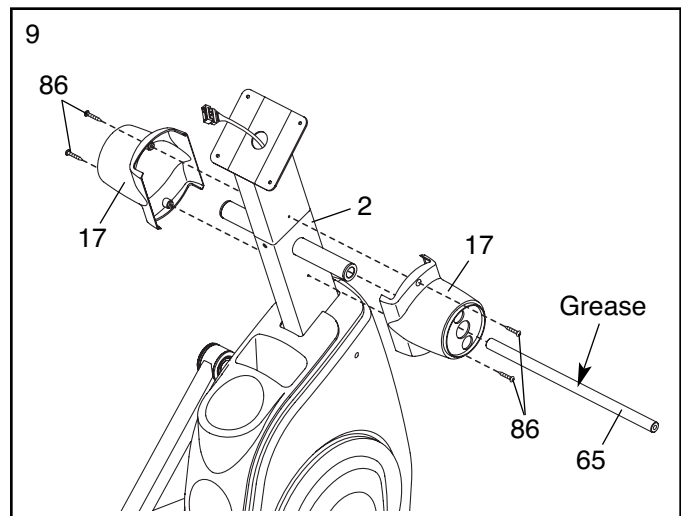

10. Identify the Right Handlebar (9), which is marked with an "R" sticker. Insert the Right Handlebar into one of the Handlebar Legs (11) as shown.

Attach the Right Handlebar (9) with two M8 x 42mm Button Bolts (71) and two M8 Nylon Locknuts (96). **Make sure that the Nylon Locknuts are inside the hexagonal holes.**

Repeat this step for the Left Handlebar (not shown) and the other Handlebar Leg (not shown).

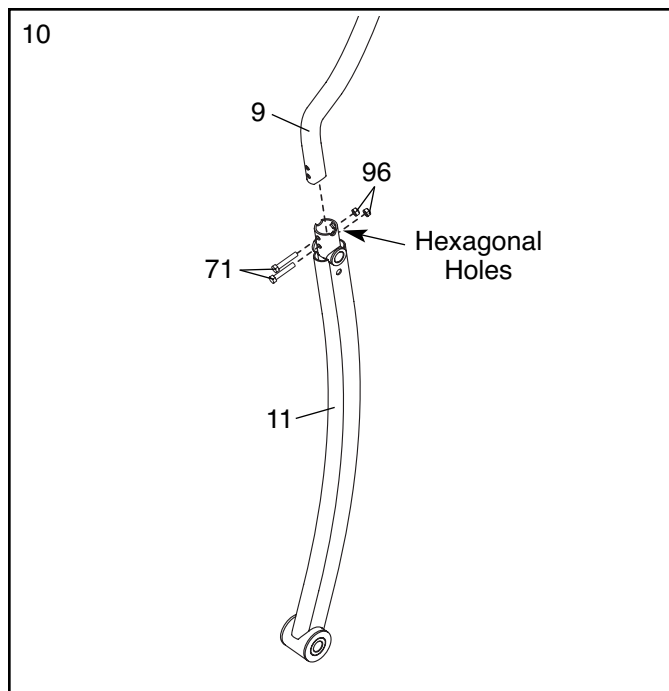

11. Orient an Inner Handlebar Cover (18) and an Outer Handlebar Cover (19) around the Right Handlebar (9) as shown.

Attach the Outer Handlebar Cover (19) with an M4 x 16mm Flange Screw (84). Then, attach the Inner Handlebar Cover (18) with two M4 x 16mm Self-tapping Screws (79).

Repeat this step for the Left Handlebar (not shown).

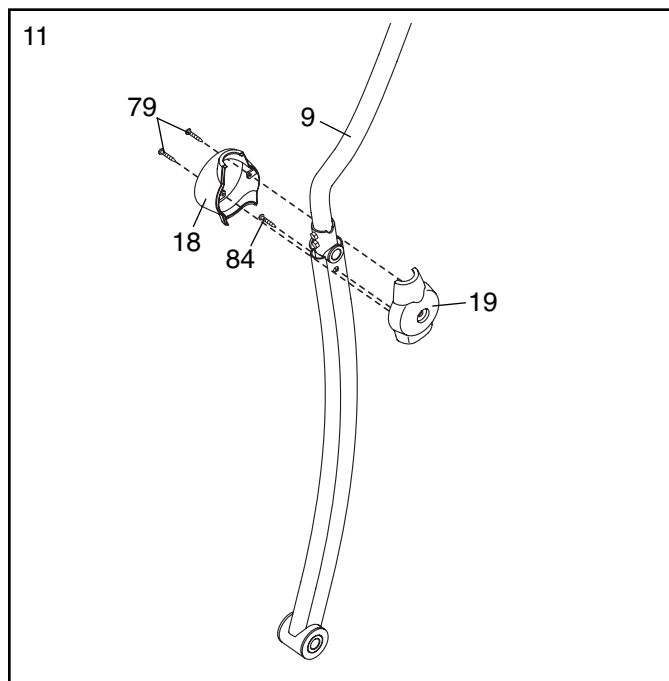

12. Apply a small amount of grease to a Wave Washer (93). Slide the Wave Washer onto the right side of the Pivot Axle (65). Next, slide the Right Handlebar (9) onto the Pivot Axle.

Attach the Right Handlebar (9) with an M10 x 23mm Shoulder Screw (80) and an M10 x 20mm x 2mm Washer (81).

Repeat this step to attach the Left Handlebar (8) to the Pivot Axle (65).

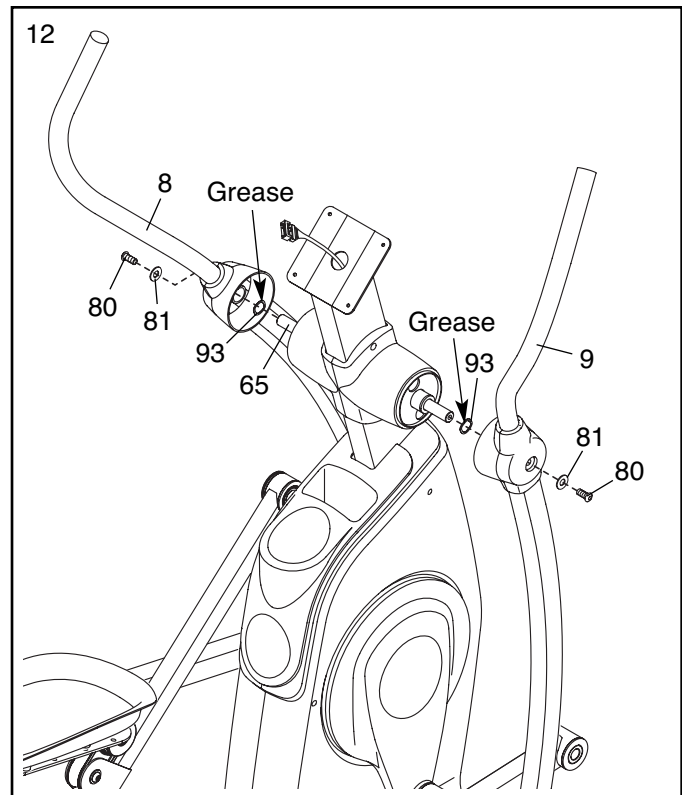

13. The Console (5) can be operated with four 1.5V “D” batteries (not included); alkaline batteries are recommended. **IMPORTANT: If the elliptical exerciser has been exposed to cold temperatures, allow it to warm to room temperature before inserting batteries into the Console. If you do not do this, the console displays or other electronic components may become damaged.** Remove the two battery screws from the back of the console, and remove the battery cover. Insert four batteries into the Console. Orient the batteries as shown by the markings inside the battery compartment. Then, reattach the battery cover. Note: If it is difficult to reattach the battery cover, remove the two battery screws, loosen the two indicated console screws a few turns, insert the lower edge of the battery cover into the console, and then retighten the two console screws. Then, reattach the battery cover with the two battery screws.

The Console (5) can also be operated with an optional power supply instead of batteries. **To purchase a power supply, call the telephone number on the front cover of this manual. To avoid damaging the console, use only a manufacturer-supplied power supply.** Plug one end of the power supply into the jack on the console. Plug the other end of the power supply into an appropriate outlet that is properly installed in accordance with all local codes and ordinances.

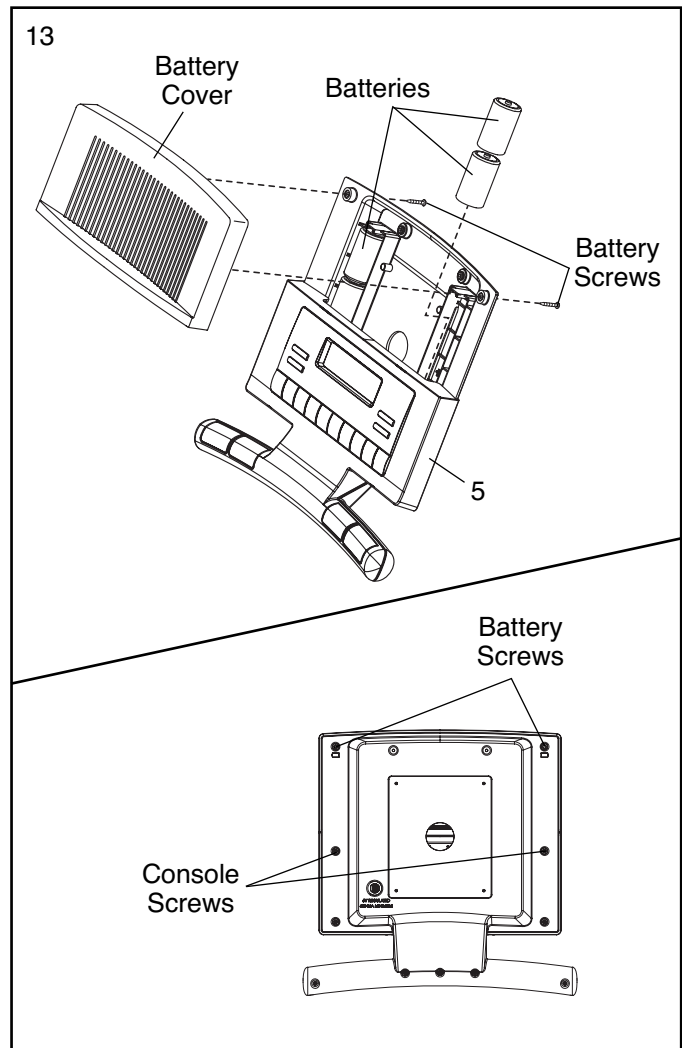

14. While a second person holds the Console (5) near the Upright (6), connect the console wire to the Wire Harness (48). Insert the excess wire downward into the Upright.

Tip: Avoid pinching the Wire Harness (48) during this step. Attach the Console (5) to the Upright (6) with four M4 x 16mm Self-tapping Screws (79).

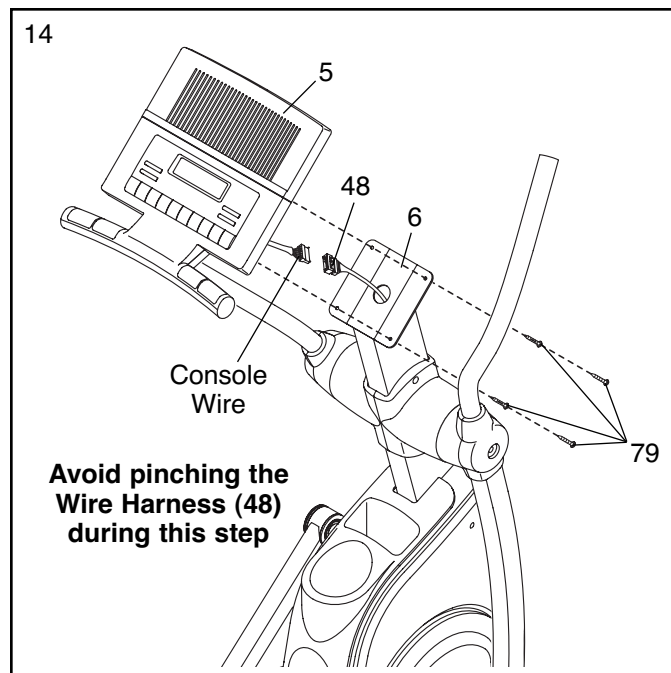

15. Apply a generous amount of grease to a Pedal Leg Axle (32). Insert the Pedal Leg Axle into the bottom of the right Handlebar Leg (11).

Apply a small amount of grease to a Wave Washer (93). Slide the Wave Washer onto the right side of the Pedal Leg Axle (32).

Orient the Right Pedal Leg (16) as shown, and slide it onto the Pedal Leg Axle (32). Attach the Right Pedal Leg to the right Handlebar Leg (11) with two M10 x 23mm Shoulder Screws (80), two Axle Caps (31), and two M10 x 25mm x 1.5mm Washers (83).

Repeat this step for the other side of the elliptical exerciser.

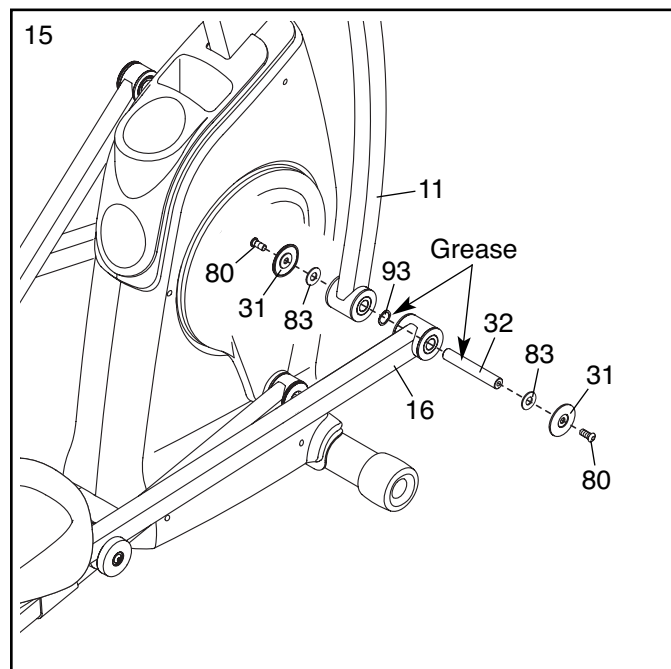

16. **Make sure that all parts of the elliptical exerciser are properly tightened.** Note: Some hardware may be left over after assembly is completed. To protect the floor or carpet from damage, place a mat under the elliptical exerciser.

HOW TO USE THE ELLIPTICAL EXERCISER

HOW TO MOVE THE ELLIPTICAL EXERCISER

Due to the size and weight of the elliptical exerciser, moving it requires two persons. Stand in front of the elliptical exerciser, hold the upright, and place one foot against one of the front wheels. Pull on the upright and have a second person lift the base until the elliptical exerciser will roll on the front wheels. Carefully move the elliptical exerciser to the desired location, and then lower it to the floor.

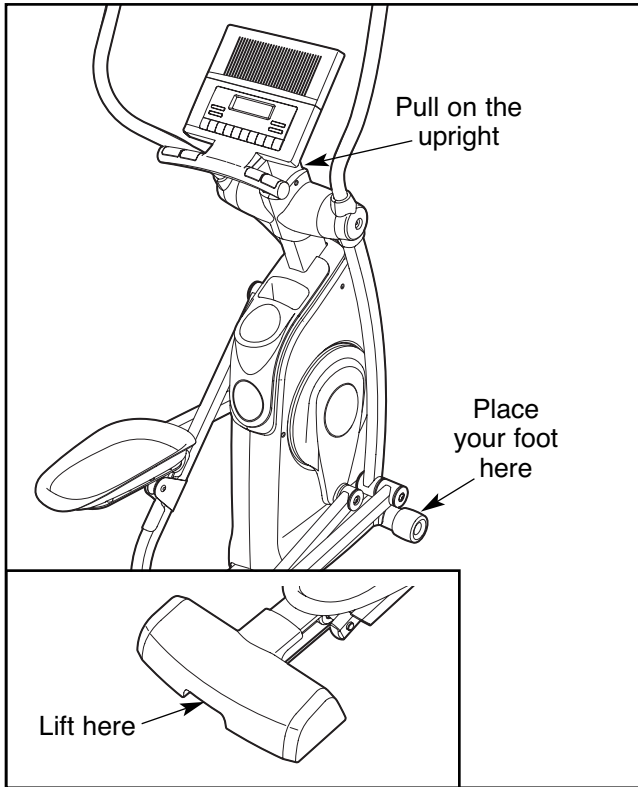

HOW TO EXERCISE ON THE ELLIPTICAL EXERCISER

To mount the elliptical exerciser, hold the handlebars and step onto the pedal that is in the lower position. Then, step onto the other pedal. Push the pedals until they begin to move with a continuous motion. **Note: The crank arm covers can turn in either direction. It is recommended that you turn the crank arm covers in the direction shown by the arrow below; however, for variety, you can turn the crank arm covers in the opposite direction.**

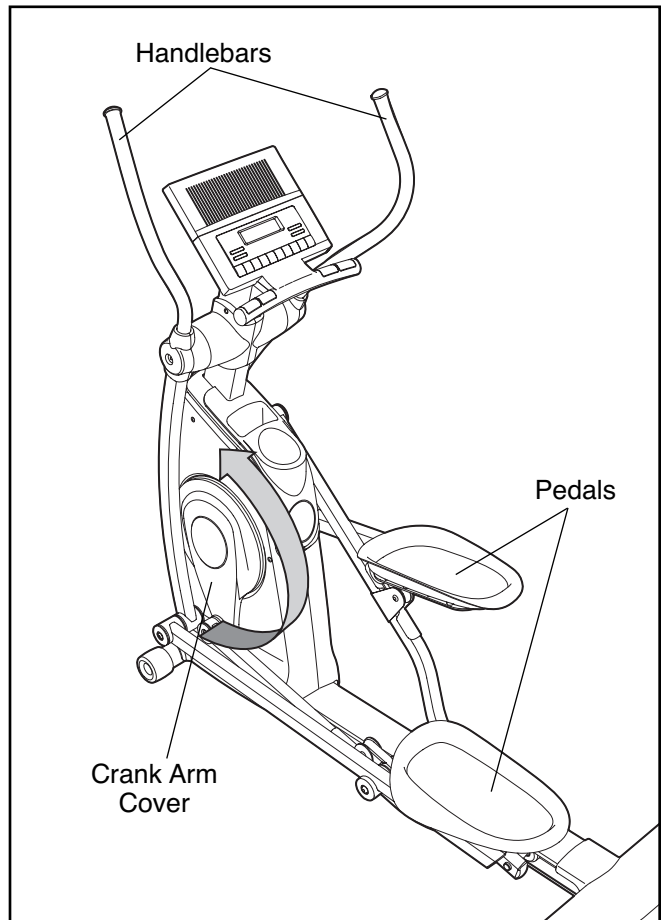

To dismount the elliptical exerciser, wait until the pedals come to a complete stop. **Note: The elliptical exerciser does not have a free wheel; the pedals will continue to move until the flywheel stops.** When the pedals are stationary, step off the higher pedal first. Then, step off the lower pedal.

HOW TO ADJUST THE SELECTOR

The pedals on the elliptical exerciser move your feet in a natural elliptical path. You can adjust the selectors on the elliptical exerciser so that the pedals move in a more vertical path or a more horizontal path.

To adjust the elliptical exerciser so that the pedals move in a more vertical path, pivot the two selectors to the high position; to adjust the elliptical exerciser so that the pedals move in a more horizontal path, pivot the selectors to the low position. **IMPORTANT: Make sure to adjust both selectors to the same position.**

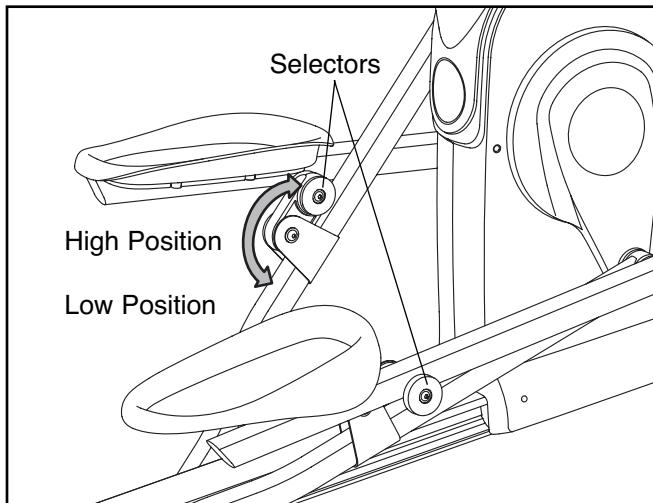

HOW TO LEVEL THE ELLIPTICAL EXERCISER

If the elliptical exerciser rocks slightly on your floor during use, turn one or both of the leveling feet beneath the base until the rocking motion is eliminated.

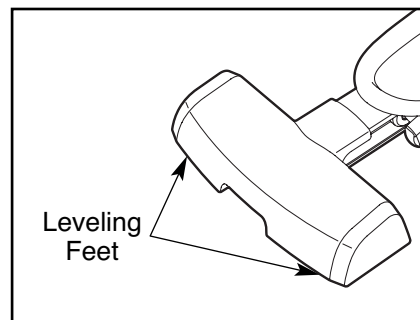

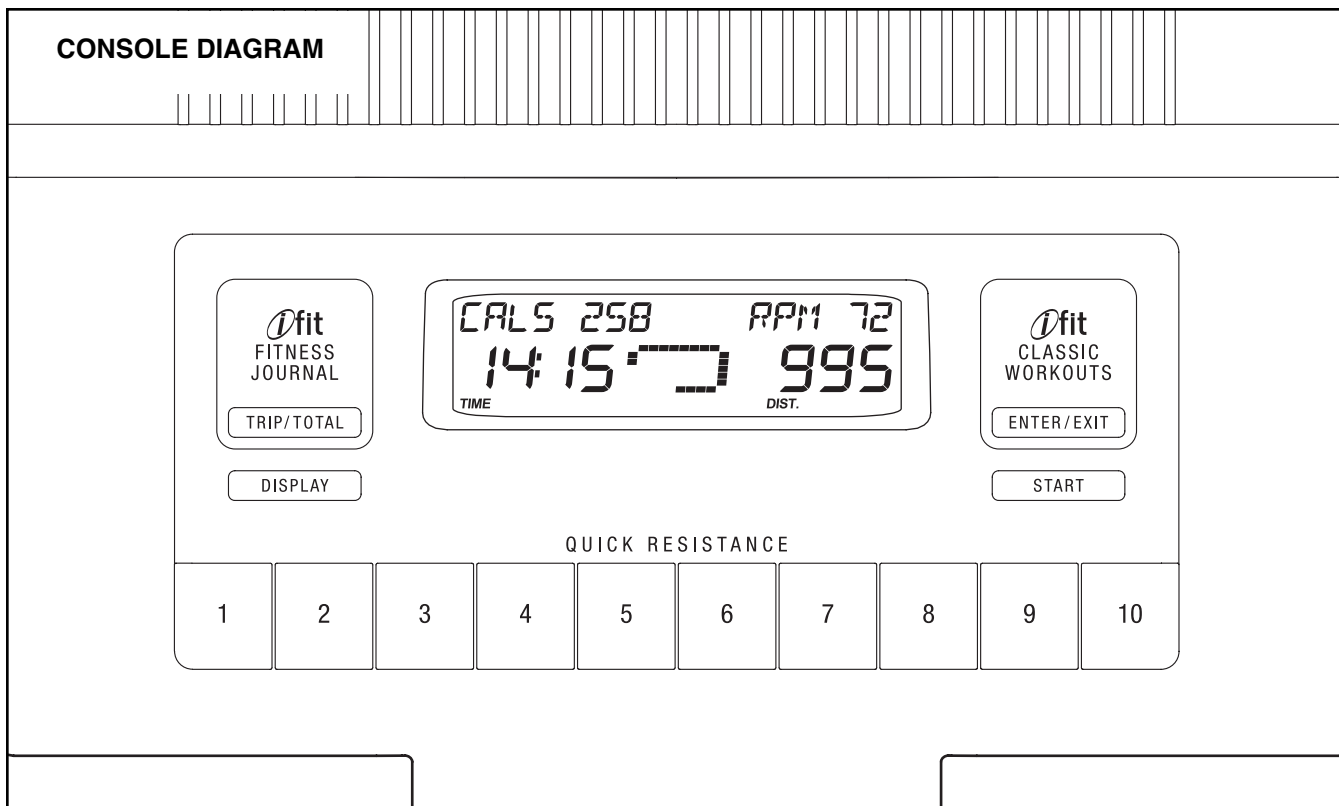

FEATURES OF THE CONSOLE

The advanced console offers an array of features designed to make your workouts more effective and enjoyable.

When you use the manual mode of the console, you can change the resistance of the pedals with the touch of a button. As you exercise, the console will display continuous exercise feedback. You can even measure your heart rate using the handgrip pulse sensor.

The console offers four weight loss workouts designed to help you burn calories and lose unwanted pounds. The console guides you through an effective weight loss workout by prompting you to vary your pace and by automatically changing the resistance of the pedals.

The console also offers eight preset workouts that automatically change the resistance of the pedals and prompt you to vary your pace while guiding you through an effective workout.

You can also use the fitness journal to view usage information for your elliptical exerciser.

To use the manual mode of the console, follow the steps beginning on page 16. **To use a weight loss workout**, see page 18. **To use a preset workout**, see page 19. **To view the fitness journal**, see page 19.

HOW TO USE THE MANUAL MODE

Note: If there is a sheet of clear plastic on the face of the console, remove the plastic.

1. Begin pedaling to turn on the console.

A moment after you turn on the console, the displays will light.

2. Select the manual mode.

Each time you turn on the console, the manual mode will be selected automatically. If you have selected a workout, reselect the manual mode by pressing the Enter/Exit button repeatedly until the words MANUAL MODE appear in the upper display.

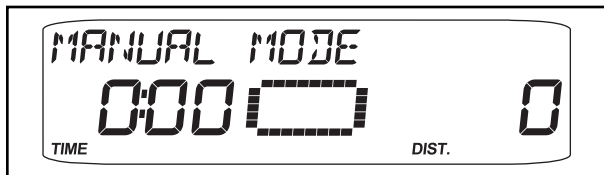

3. Press the Start button or begin pedaling and change the resistance of the pedals as desired.

As you pedal, change the resistance of the pedals by pressing one of the ten numbered Quick Resistance buttons. Note: After you press the buttons, it will take a moment for the pedals to reach the selected resistance level.

4. Follow your progress with the displays.

The left display—This display will show the elapsed time. Note: When you select a workout, the display will show the time remaining in the workout instead of the elapsed time.

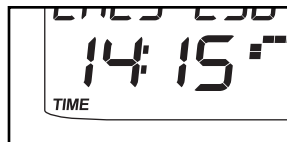

The left display will also show your heart rate when you use the handgrip pulse sensor (see step 5 on page 17).

When you select a workout, the left display will also show the approximate number of calories you have burned.

The center display—When you select the manual mode, this display will show a track that represents 640 revolutions. As you exercise, indicators will appear in succession around the track until the entire track appears. The track will then disappear and the indicators will again begin to appear in succession.

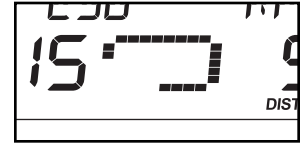

The center display will also show the resistance level of the pedals for a few seconds each time the resistance level changes.

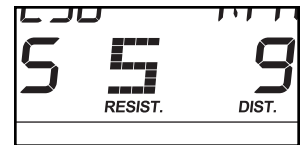

The right display—This display will show the distance (total revolutions) you have pedaled.

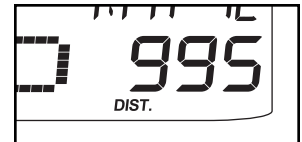

When you select a workout, the right display will also show your pedaling pace, in revolutions per minute (rpm).

The upper display—When you select the manual mode, the upper display will show the approximate number of calories you have burned and your pedaling pace in revolutions per minute (rpm).



Note: When you select a workout, you can change the display mode to view the exercise information you are most interested in viewing. To change the display mode, press the Display button repeatedly until the desired exercise information appears in the left or right display. After several seconds, the display mode will change automatically as before.

5. Measure your heart rate if desired.

If there are sheets of clear plastic on the metal contacts on the handgrip pulse sensor, remove the plastic. To measure your heart rate, hold the handgrip pulse sensor with your palms resting against the metal contacts. **Avoid moving your hands or gripping the contacts tightly.**

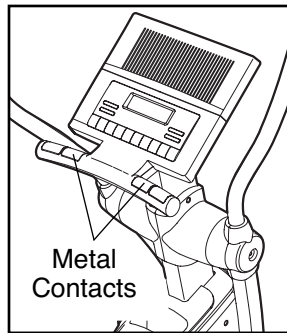

When your pulse is detected, a heart-shaped symbol will flash in the left display. Each time your heart beats, one or two dashes will appear, and then your heart rate will be shown. For the most accurate heart rate reading, hold the contacts for at least 15 seconds. Note: If you continue to hold the handgrip pulse sensor, the display will show your heart rate for up to 30 seconds.



If your heart rate is not shown, make sure that your hands are positioned as described. Be careful not to move your hands excessively or to squeeze the metal contacts tightly. For optimal performance, clean the metal contacts using a soft cloth; **never use alcohol, abrasives, or chemicals to clean the contacts.**

6. When you are finished exercising, the console will turn off automatically.

If the pedals do not move for several seconds, a series of tones will sound, the console will pause, and the time will flash in the display.

If the pedals do not move for about five minutes, the console will turn off and the display will be reset.

HOW TO USE A WEIGHT LOSS WORKOUT

1. Begin pedaling to turn on the console.

See step 1 on page 16.

2. Select a weight loss workout.

To select one of the four weight loss workouts, press the Enter/Exit button repeatedly until the name of a WEIGHT LOSS workout appears in the upper display.

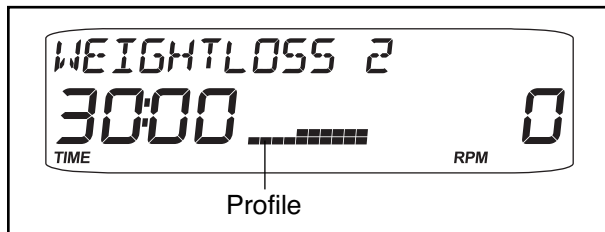

When you select a weight loss workout, the name of the workout and the workout time will appear in the displays and a profile of the resistance levels of the workout will scroll across the center display.

3. Press Start or begin pedaling to start the workout.

Each weight loss workout is divided into 25, 30, or 45 one-minute segments. One resistance level and one target rpm (revolutions per minute) setting are programmed for each segment. Note: The same resistance level and/or target rpm setting may be programmed for consecutive segments.

During the workout, the workout profile will show your progress (see the drawing above). The flashing segment of the profile represents the current segment of the workout. The height of the flashing segment indicates the resistance level for the current segment. At the end of each segment of the workout, a series of tones will sound and the next segment of the profile will begin to flash. If a different resistance level is programmed for the next segment, the resistance level will appear in the display for a few seconds to alert you. The resistance of the pedals will then change.

As you exercise, you will be prompted to keep your pedaling pace near the target rpm setting for the current segment. When the words PEDAL FASTER appear in the upper display, increase your pace. When the words PEDAL SLOWER appear, decrease your pace. When the words PEDALING IN RANGE appear, maintain your current pace.

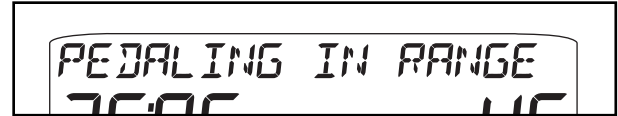

IMPORTANT: The target rpm settings are intended only to provide motivation. Your actual pace may be slower than the target rpm settings. Make sure to pedal at a pace that is comfortable for you.

If the resistance level for the current segment is too high or too low, you can manually override the setting by pressing the Quick Resistance buttons. However, when the current segment ends, the pedals will automatically adjust to the resistance level for the next segment.

If you stop pedaling for several seconds, a series of tones will sound and the workout will pause. To restart the workout, simply resume pedaling. The workout will continue until the last segment of the profile flashes and the last segment of the workout ends.

When the last segment of the workout ends, the words PROGRAM DONE will appear in the upper display.

4. Follow your progress with the displays.

See step 4 on page 16.

5. Measure your heart rate if desired.

See step 5 on page 17.

6. When you are finished exercising, the console will turn off automatically.

See step 6 on page 17.

HOW TO USE A PRESET WORKOUT

1. Begin pedaling to turn on the console.

See step 1 on page 16.

2. Select a preset workout.

To select one of the eight preset workouts, press the Enter/Exit button repeatedly until the name of a WORKOUT appears in the upper display.

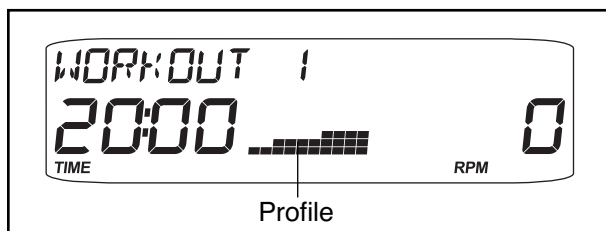

When you select a preset workout, the name of the workout and the workout time will appear in the displays and a profile of the resistance levels of the workout will scroll across the center display.

3. Press Start or begin pedaling to start the workout.

The workout is divided into 20, 30, or 45 one-minute segments. One resistance level and one target rpm setting are programmed for each segment. Note: The same resistance level and/or target rpm (revolutions per minute) setting may be programmed for consecutive segments. The displays for a preset workout will work in the same way as the displays for a weight loss workout (see step 3 on page 18).

As you exercise, you will be prompted to keep your pedaling pace near the target rpm setting for the current segment. When the words PEDAL FASTER appear in the upper display, increase your pace. When the words PEDAL SLOWER appear, decrease your pace. When the words PEDALING IN RANGE appear, maintain your current pace.

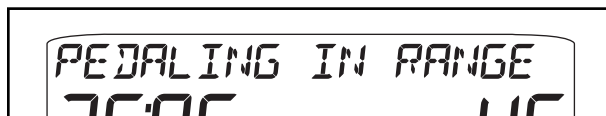

IMPORTANT: The target rpm settings are intended only to provide motivation. Your actual pace may be slower than the target rpm settings. Make sure to pedal at a pace that is comfortable for you.

If the resistance level for the current segment is too high or too low, you can manually override the setting by pressing the Quick Resistance buttons. However, when the current segment ends, the pedals will automatically adjust to the resistance level for the next segment.

If you stop pedaling for several seconds, a series of tones will sound and the workout will pause. To restart the workout, simply resume pedaling. The workout will continue until the last segment of the profile flashes and the last segment of the workout ends.

When the last segment of the workout ends, the words PROGRAM DONE will appear in the upper display.

4. Follow your progress with the displays.

See step 4 on page 16.

5. Measure your heart rate if desired.

See step 5 on page 17.

6. When you are finished exercising, the console will turn off automatically.

See step 6 on page 17.

HOW TO VIEW THE FITNESS JOURNAL

To view the fitness journal, press the Trip/Total button. The trip distance for your current workout and the number of hours the elliptical exerciser has been used during the current workout will appear in the display. Note: The trip distance will be reset each time you use the console.

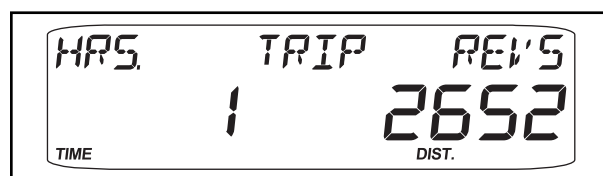

To view the total distance pedaled and the total number of hours the elliptical exerciser has been used since the elliptical exerciser was purchased, press the Trip/Total button again. Note: When the word K-REVS appears in the upper display, the number shown in the right display multiplied by one thousand equals the total distance.

To exit the fitness journal, press the Trip/Total button a third time.

MAINTENANCE AND TROUBLESHOOTING

Inspect and tighten all parts of the elliptical exerciser regularly. Replace any worn parts immediately.

To clean the elliptical exerciser, use a damp cloth and a small amount of mild soap. **IMPORTANT: To avoid damage to the console, keep liquids away from the console and keep the console out of direct sunlight.**

BATTERY REPLACEMENT

If the console display becomes dim, the batteries should be replaced; most console problems are the result of low batteries. See assembly step 13 on page 11 for replacement instructions.

HOW TO LEVEL THE ELLIPTICAL EXERCISER

If the elliptical exerciser rocks slightly on your floor during use, see HOW TO LEVEL THE ELLIPTICAL EXERCISER on page 14.

HOW TO ADJUST THE REED SWITCH

If the console does not display correct feedback, the reed switch should be adjusted. To adjust the reed switch, first remove the screws from the left and right side shields; **there are two sizes of screws in the side shields—note which size of screw you remove from each hole.** Gently pull the side shields apart and remove the convenience tray.

Next, see the drawing below and locate the Reed Switch (50). Loosen, but do not remove, the indicated M4 x 16mm Self-tapping Screw (79). Slide the Reed Switch slightly toward or away from a Magnet (55) on the flywheel.

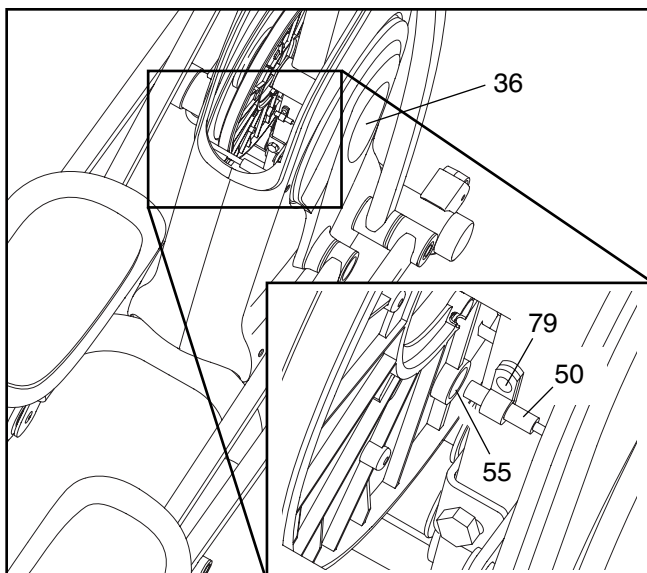

Then, retighten the Screw. Turn one of the Crank Arms (36) for a moment. Repeat until the console displays correct feedback. When the Reed Switch is correctly adjusted, replace the convenience tray and reattach the left and right side shields.

HOW TO ADJUST THE DRIVE BELT

If the pedals slip while you are pedaling, even while the resistance is adjusted to the highest setting, the drive belt may need to be adjusted. To adjust the drive belt, first remove the screws from the left and right side shields; **there are two sizes of screws in the side shields—note which size of screw you remove from each hole.** Gently pull the side shields apart and remove the convenience tray.

Next, locate the Idler Screw (68) and loosen it one half turn. Step onto the elliptical exerciser and move the pedals. If the pedals continue to slip, turn the Idler Screw another half turn and test the pedals again. Continue in this way until the pedals no longer slip. Then, replace the convenience tray and reattach the side shields.

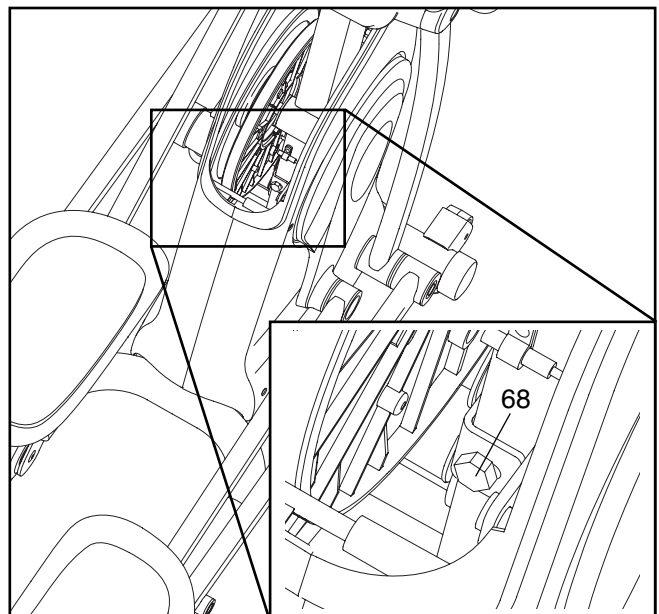

EXERCISE GUIDELINES

⚠ WARNING: Before beginning this or any exercise program, consult your physician. This is especially important for persons over the age of 35 or persons with pre-existing health problems.

The pulse sensor is not a medical device. Various factors may affect the accuracy of heart rate readings. The pulse sensor is intended only as an exercise aid in determining heart rate trends in general.

These guidelines will help you to plan your exercise program. For detailed exercise information, obtain a reputable book or consult your physician. Remember, proper nutrition and adequate rest are essential for successful results.

EXERCISE INTENSITY

Whether your goal is to burn fat or to strengthen your cardiovascular system, exercising at the proper intensity is the key to achieving results. You can use your heart rate as a guide to find the proper intensity level. The chart below shows recommended heart rates for fat burning and aerobic exercise.

165	155	145	140	130	125	115	♥
145	138	130	125	118	110	103	♥
125	120	115	110	105	95	90	♥
<hr/>							
20	30	40	50	60	70	80	

To find the proper intensity level, find your age at the bottom of the chart (ages are rounded off to the nearest ten years). The three numbers listed above your age define your “training zone.” The lowest number is the heart rate for fat burning, the middle number is the heart rate for maximum fat burning, and the highest number is the heart rate for aerobic exercise.

Burning Fat—To burn fat effectively, you must exercise at a low intensity level for a sustained period of time. During the first few minutes of exercise, your body uses *carbohydrate calories* for energy. Only after the first few minutes of exercise does your body begin to use stored *fat calories* for energy. If your goal is to burn fat, adjust the intensity of your exercise until your heart rate is near the lowest number in your training zone. For maximum fat burning, exercise with your heart rate near the middle number in your training zone.

Aerobic Exercise—If your goal is to strengthen your cardiovascular system, you must perform aerobic exercise, which is activity that requires large amounts of oxygen for prolonged periods of time. For aerobic exercise, adjust the intensity of your exercise until your heart rate is near the highest number in your training zone.

WORKOUT GUIDELINES

Warming up—Start with 5 to 10 minutes of stretching and light exercise. A warm-up increases your body temperature, heart rate, and circulation in preparation for exercise.

Training Zone Exercise—Exercise for 20 to 30 minutes with your heart rate in your training zone. (During the first few weeks of your exercise program, do not keep your heart rate in your training zone for longer than 20 minutes.) Breathe regularly and deeply as you exercise—never hold your breath.

Cooling down—Finish with 5 to 10 minutes of stretching. Stretching increases the flexibility of your muscles and helps to prevent post-exercise problems.

EXERCISE FREQUENCY

To maintain or improve your condition, complete three workouts each week, with at least one day of rest between workouts. After a few months of regular exercise, you may complete up to five workouts each week, if desired. Remember, the key to success is to make exercise a regular and enjoyable part of your everyday life.

SUGGESTED STRETCHES

The correct form for several basic stretches is shown at the right. Move slowly as you stretch—never bounce.

1. Toe Touch Stretch

Stand with your knees bent slightly and slowly bend forward from your hips. Allow your back and shoulders to relax as you reach down toward your toes as far as possible. Hold for 15 counts, then relax. Repeat 3 times. Stretches: Hamstrings, back of knees and back.

2. Hamstring Stretch

Sit with one leg extended. Bring the sole of the opposite foot toward you and rest it against the inner thigh of your extended leg. Reach toward your toes as far as possible. Hold for 15 counts, then relax. Repeat 3 times for each leg. Stretches: Hamstrings, lower back and groin.

3. Calf/Achilles Stretch

With one leg in front of the other, reach forward and place your hands against a wall. Keep your back leg straight and your back foot flat on the floor. Bend your front leg, lean forward and move your hips toward the wall. Hold for 15 counts, then relax. Repeat 3 times for each leg. To cause further stretching of the achilles tendons, bend your back leg as well. Stretches: Calves, achilles tendons and ankles.

4. Quadriceps Stretch

With one hand against a wall for balance, reach back and grasp one foot with your other hand. Bring your heel as close to your buttocks as possible. Hold for 15 counts, then relax. Repeat 3 times for each leg. Stretches: Quadriceps and hip muscles.

5. Inner Thigh Stretch

Sit with the soles of your feet together and your knees outward. Pull your feet toward your groin area as far as possible. Hold for 15 counts, then relax. Repeat 3 times. Stretches: Quadriceps and hip muscles.

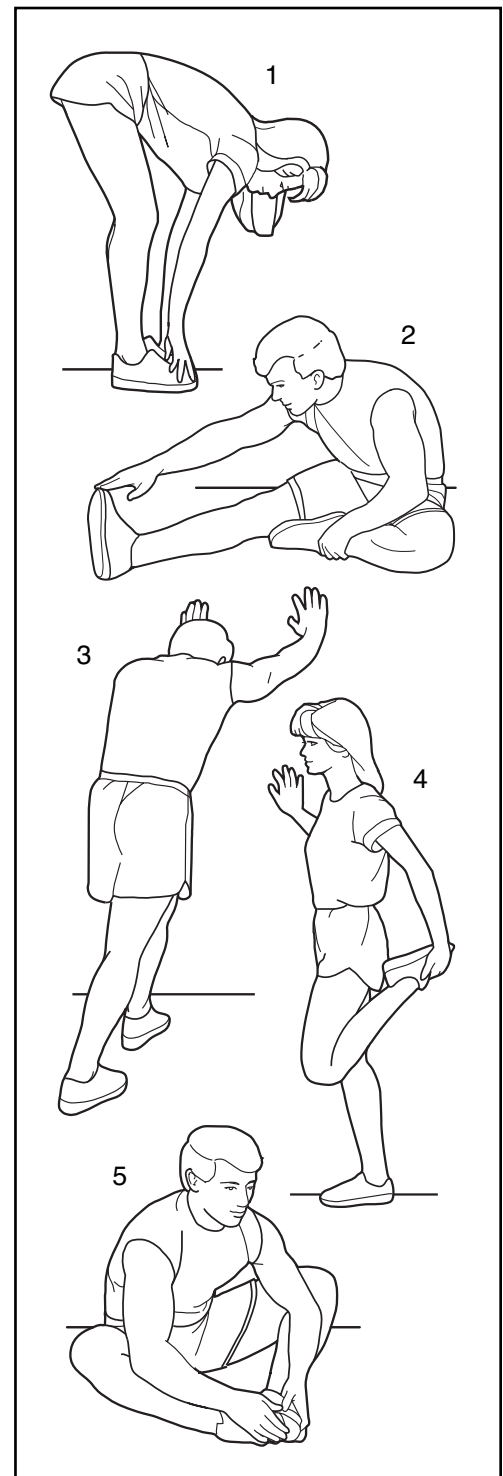

PART LIST—Model No. PFEL05807.0

R1007A

Key No.	Qty.	Description	Key No.	Qty.	Description
1	1	Base	41	12	Axle Bushing
2	1	Frame	42	2	Pedal Leg Endcap
3	2	Outer Crank Arm Cover	43	1	Crank Sleeve
4	2	Inner Crank Arm Cover	44	2	Crank Bearing Set
5	1	Console	45	1	Crank
6	1	Upright	46	2	Selector Cover
7	2	Roller Cover	47	4	Snap Ring
8	1	Left Handlebar	48	1	Wire Harness
9	1	Right Handlebar	49	2	Selector Spacer
10	2	Handlebar Endcap	50	1	Reed Switch/Wire
11	2	Handlebar Leg	51	1	Belt
12	1	Left Roller Leg	52	1	Flywheel
13	1	Left Pedal	53	1	"C" Magnet
14	1	Left Pedal Leg	54	2	Outer Bearing Set
15	1	Right Pedal	55	2	Magnet
16	1	Right Pedal Leg	56	1	Spring
17	2	Frame Cover	57	1	Idler
18	2	Inner Handlebar Cover	58	1	Flywheel Pulley
19	2	Outer Handlebar Cover	59	1	Clamp
20	2	Axle Bearing	60	2	Inner Bearing Set
21	1	Right Roller Leg	61	1	Motor
22	2	Roller	62	1	Resistance Cable Pulley
23	1	Rear Frame Cover	63	1	Resistance Cable Set
24	2	Roller Axle	64	2	Foam Grip
25	2	Wheel	65	1	Pivot Axle
26	2	Foot	66	2	Hub Cover
27	1	Center Frame Cover	67	1	Stop Screw
28	1	Left Side Shield	68	1	Idler Screw
29	1	Right Side Shield	69	1	M8 Flange Screw
30	2	Crank Axle Cap	70	4	M8 x 35mm Screw
31	4	Axle Cap	71	4	M8 x 42mm Button Bolt
32	2	Pedal Leg Axle	72	2	M10 Split Washer
33	8	Axle Bushing	73	10	M4 x 12mm Flange Screw
34	2	Selector	74	8	M8 x 25mm Screw
35	2	Selector Axle	75	2	3/8" Flange Screw
36	2	Crank Arm	76	2	M10 Spacer
37	1	Convenience Tray	77	2	Pivot Bushing
38	2	Crank Hub	78	2	M10 x 48mm Button Screw
39	1	Pulley Spacer	79	20	M4 x 16mm Self-tapping Screw
40	1	Pulley	80	8	M10 x 23mm Shoulder Screw

Key No.	Qty.	Description	Key No.	Qty.	Description
81	4	M10 x 20mm x 2mm Washer	92	1	M4 x 12mm Screw
82	8	M10 x 15mm Patch Screw	93	8	Wave Washer
83	12	M10 x 25mm x 1.5mm Washer	94	2	M10 X 35mm Shoulder Screw
84	2	M4 x 16mm Flange Screw	95	3	M8 x 16mm Button Screw
85	8	M4 x 12mm Screw	96	6	M8 Nylon Locknut
86	6	M4 x 16mm Screw	97	2	M10 x 62mm Button Bolt
87	8	M6 x 16mm Phillips Screw	98	2	Selector Axle Cap
88	8	M6 Split Washer	*	–	Hex Key
89	2	“E” Clip	*	–	Grease Packet
90	1	Cover	*	–	User’s Manual
91	4	M4 x 65mm Screw			

Specifications are subject to change without notice. See the back cover of this manual for information about ordering replacement parts. *These parts are not illustrated.

EXPLODED DRAWING A—Model No. PFEL05807.0

R1007A

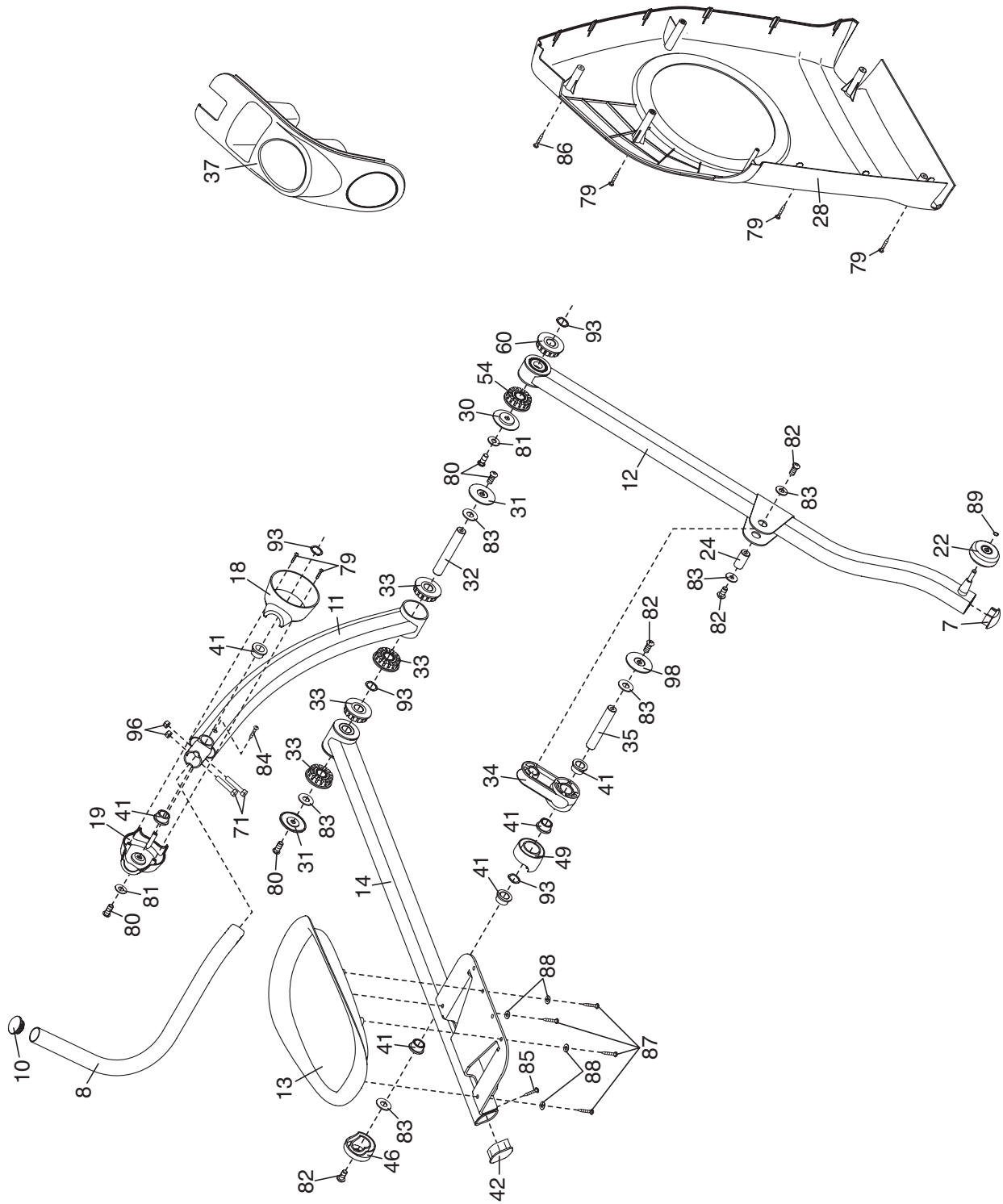

EXPLODED DRAWING C—Model No. PFEL05807.0

R1007A

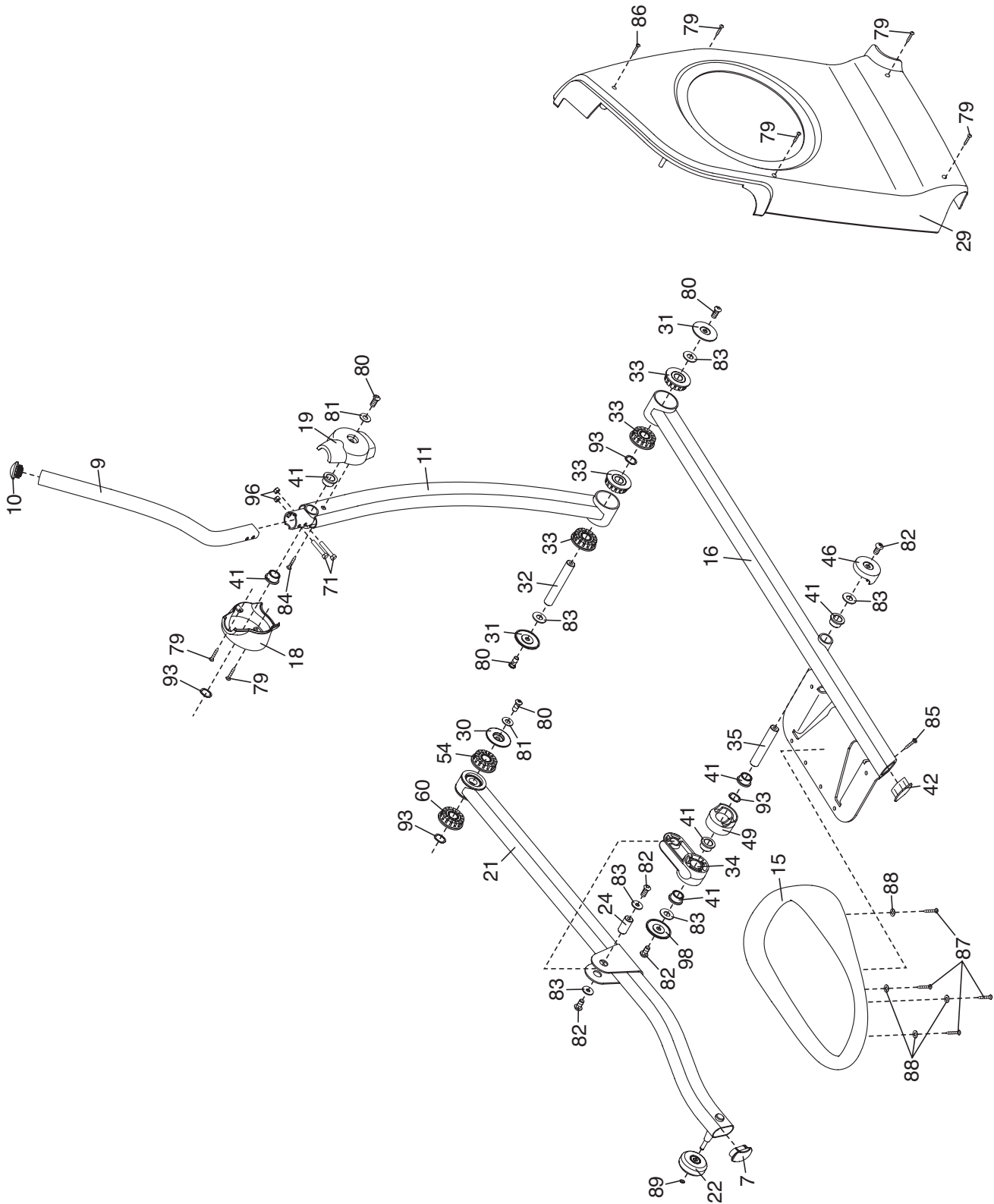

ORDERING REPLACEMENT PARTS

To order replacement parts, please see the front cover of this manual. To help us assist you, be prepared to provide the following information when contacting us:

- the model number and serial number of the product (see the front cover of this manual)
- the name of the product (see the front cover of this manual)
- the key number and description of the replacement part(s) (see the PART LIST and the EXPLODED DRAWING near the end of this manual)

LIMITED WARRANTY

ICON Health & Fitness, Inc. (ICON) warrants this product to be free from defects in workmanship and material, under normal use and service conditions, for a period of one (1) year from the date of purchase. There is a seven (7) year warranty on the resistance mechanism. There is a lifetime warranty on the frame. This warranty extends only to the original purchaser. ICON's obligation under this warranty is limited to replacing or repairing, at ICON's option, the product through one of its authorized service centers. All repairs for which warranty claims are made must be pre-authorized by ICON. If the product is shipped to a service center, freight charges to and from the service center will be the customer's responsibility. For in-home service, the customer will be responsible for a minimal trip charge. This warranty does not extend to any product or damage to a product caused by or attributable to freight damage, abuse, misuse, improper or abnormal usage or repairs not provided by an ICON authorized service center; products used for commercial or rental purposes; or products used as store display models. No other warranty beyond that specifically set forth above is authorized by ICON.

ICON is not responsible or liable for indirect, special or consequential damages arising out of or in connection with the use or performance of the product or damages with respect to any economic loss, loss of property, loss of revenues or profits, loss of enjoyment or use, costs of removal or installation or other consequential damages of whatsoever nature. Some states do not allow the exclusion or limitation of incidental or consequential damages. Accordingly, the above limitation may not apply to you.

The warranty extended hereunder is in lieu of any and all other warranties and any implied warranties of merchantability or fitness for a particular purpose is limited in its scope and duration to the terms set forth herein. Some states do not allow limitations on how long an implied warranty lasts. Accordingly, the above limitation may not apply to you.

This warranty gives you specific legal rights. You may also have other rights which vary from state to state.

ICON HEALTH & FITNESS, INC., 1500 S. 1000 W., LOGAN, UT 84321-9813