

PRO·FORM® 940S

E K G G R I P P U L S E

Model No. 831.288070

Serial No. _____

Write the serial number in the space above for future reference.

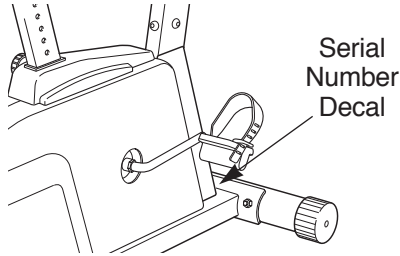

USER'S MANUAL

QUESTIONS?

As a manufacturer, we are committed to providing complete customer satisfaction. If you have questions, or if there are missing or damaged parts, we will guarantee complete satisfaction through direct assistance from our factory.

TO AVOID UNNECESSARY DELAYS, PLEASE CALL DIRECT TO OUR TOLL-FREE CUSTOMER HOT LINE. The trained technicians on our customer hot line will provide immediate assistance, free of charge to you.

CUSTOMER HOT LINE:

1-800-999-3756

Mon.–Fri., 6 a.m.–6 p.m. MST

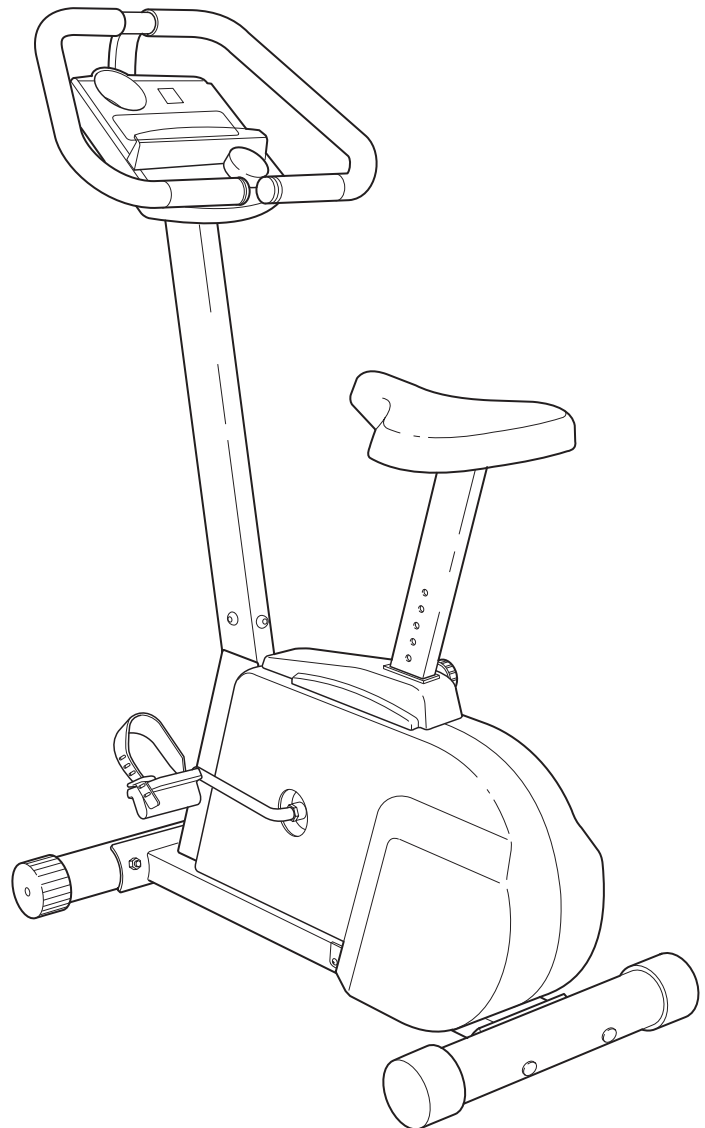

CAUTION

Read all precautions and instructions in this manual before using this equipment. Keep this manual for future reference.



Visit our website at

www.proform.com

new products, prizes,
fitness tips, and much more!

PRO·FORM® 940S

E K G G R I P P U L S E

TABLE OF CONTENTS

IMPORTANT PRECAUTIONS3
BEFORE YOU BEGIN4
PART IDENTIFICATION CHART5
ASSEMBLY6
HOW TO USE THE EXERCISE CYCLE8
CONDITIONING GUIDELINES10
MAINTENANCE AND TROUBLE-SHOOTING12
PART LIST14
EXPLODED DRAWING15
HOW TO ORDER REPLACEMENT PARTSBack Cover

IMPORTANT PRECAUTIONS

⚠ WARNING: To reduce the risk of serious injury, read the following important precautions before using the exercise cycle.

1. Read all instructions in this manual before using the exercise cycle. Use the exercise cycle only as described.
2. It is the responsibility of the owner to ensure that all users of the exercise cycle are adequately informed of all precautions.
3. Use the exercise cycle indoors, away from moisture and dust. Place the exercise cycle on a level surface, with a mat beneath it to protect the floor or carpet from damage.
4. Inspect and tighten all parts regularly. Replace any worn parts immediately.
5. Keep children under the age of 12 and pets away from the exercise cycle at all times.
6. The exercise cycle should not be used by persons weighing more than 250 pounds.
7. Wear appropriate clothing when exercising; do not wear loose clothing that could become caught on the exercise cycle. Always wear athletic shoes for foot protection.
8. When adjusting the seat, insert the seat knob through one of the holes in the seat post (see the drawing on page 4). Do not insert the seat knob under the seat post.
9. Always keep your back straight when using the exercise cycle. Do not arch your back.
10. If you feel pain or dizziness at any time while exercising, stop immediately and begin cooling down.
11. The exercise cycle does not have a free-wheel; the pedals will continue to move until the flywheel stops.
12. The exercise cycle is intended for in-home use only. Do not use the exercise cycle in a commercial, rental, or institutional setting.

⚠ WARNING: Before beginning this or any exercise program, consult your physician. This is especially important for persons over the age of 35 or persons with pre-existing health problems. Read all instructions before using. ICON assumes no responsibility for personal injury or property damage sustained by or through the use of this product.

BEFORE YOU BEGIN

Thank you for selecting the new PROFORM® 940s exercise cycle. The 940s blends advanced engineering with contemporary styling to provide you with a low-impact workout in the convenience and privacy of your own home.

For your benefit, read this manual carefully before you use the 940s. If you have additional questions, please call our Customer Service Department toll-free at 1-800-999-3756, Monday through Friday, 6 a.m.

until 6 p.m. Mountain Time (excluding holidays). To help us assist you, please mention the product model number and serial number when calling. The model number is 831.288070. The serial number can be found on a decal attached to the 940s (see the front cover of this manual for the location of the decal).

Before reading further, please look at the drawing below and familiarize yourself with the parts that are labeled.

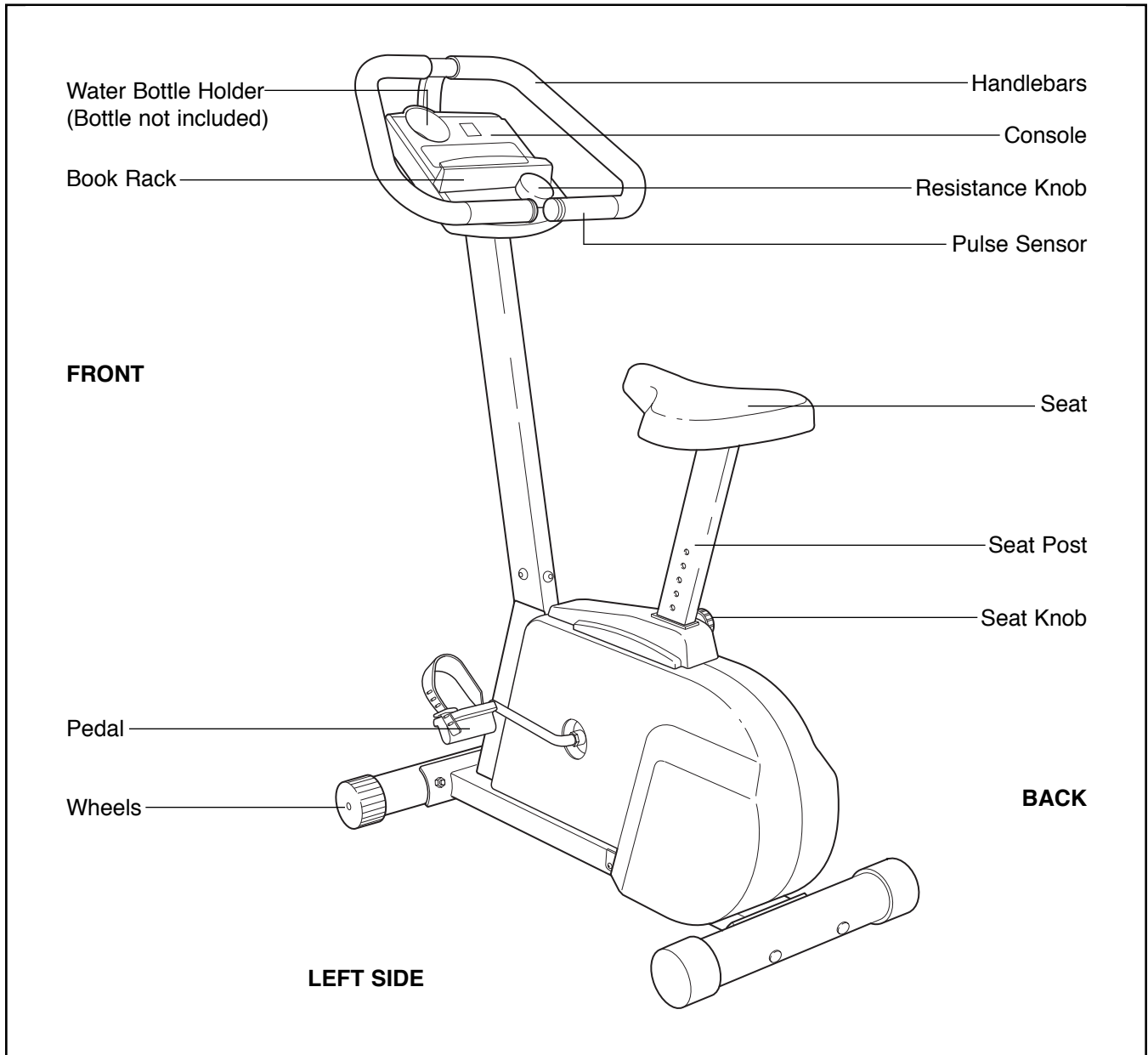

PART IDENTIFICATION CHART

Use the chart below for help identifying the small parts used in assembly. The number in parenthesis below each part refers to the key number of the part. The second number refers to the quantity used in

assembly. **Note: Some parts may have been pre-attached for shipping purposes. If a part is not found in the parts bag, check to see if it has been pre-attached.**

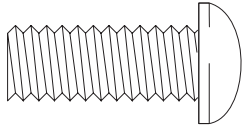

M10 x 25mm Button Screw (8)–5



M8 x 90mm Carriage Bolt (30)–4



M4 x 12mm Console Screw (4)–4

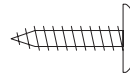

M4 x 16mm Screw (9)–1

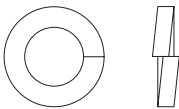

M8 Split Washer (49)–4

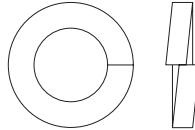

M10 Split Washer (41)–5

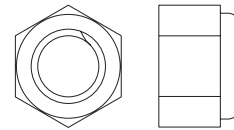

M8 Nylon Locknut (21)–8

ASSEMBLY

Place all parts of the exercise cycle in a cleared area and remove the packing materials. **Do not dispose of the packing materials until assembly is completed.**

Assembly requires the included allen wrench  , a phillips screwdriver  and two adjustable wrenches  .

1. Carefully slide the Handlebar Post (14) onto the Frame (15). **Be careful to avoid pinching the wires inside the Handlebar Post.** Attach the Handlebar Post with three M10 x 25mm Button Screws (8) and three M10 Split Washers (41).

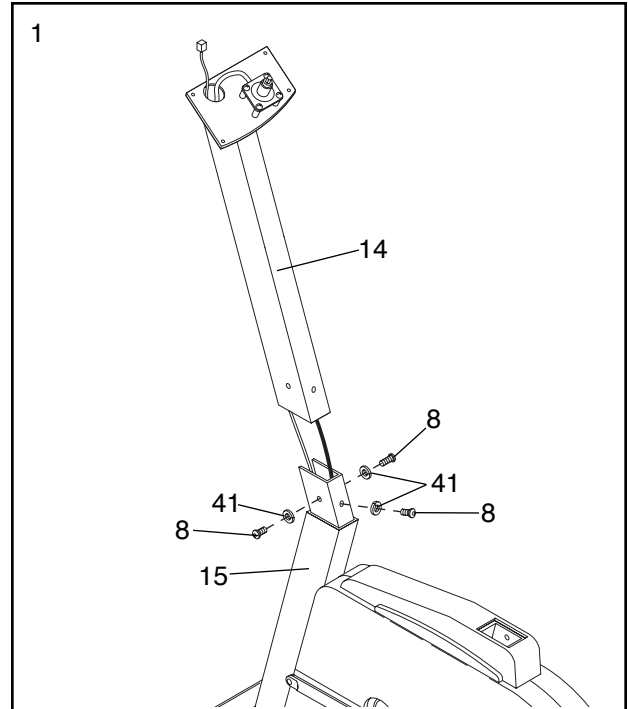

2. Identify the Front Stabilizer (17), which has Wheels (25) on the ends.

Hold the Front Stabilizer (17) against the saddle on the front of the Frame (15). Attach the Front Stabilizer with two M8 x 90mm Carriage Bolts (30) and two M8 Nylon Locknuts (21).

Attach the Rear Stabilizer (not shown) in the same manner.

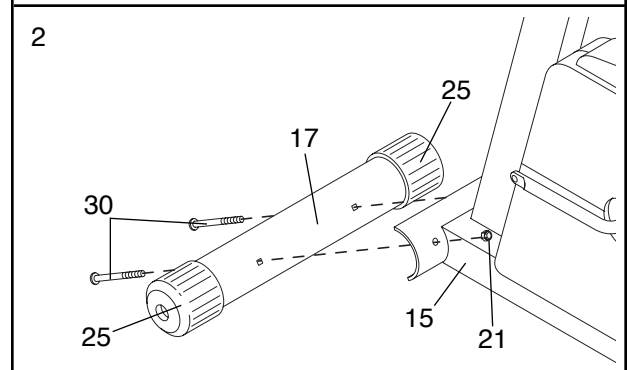

3. Insert the Pulse Grip Wires (60) through the holes in the Handlebar Post (14) as shown. Attach the Handlebar (5) to the Handlebar Post with two M10 x 25mm Button Screws (8) and two M10 Split Washers (41). **Be careful to avoid pinching the wires inside the Handlebar and Handlebar Post.**

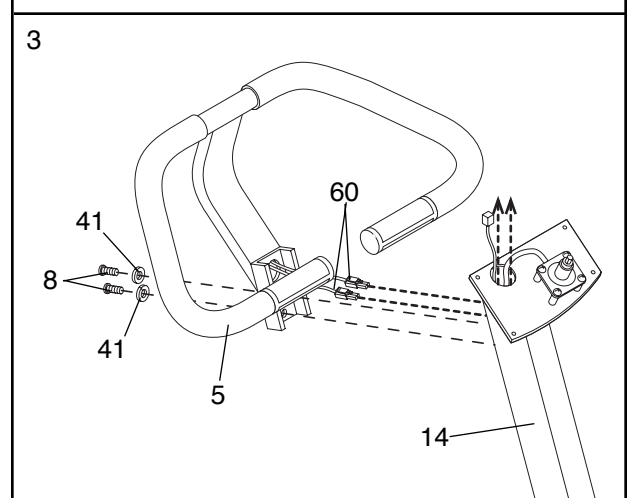

- The Console (7) requires two “AA” batteries (not included). Alkaline batteries are recommended. Refer to the inset drawing. Open the battery cover on the underside of the Console as shown. Press two batteries into the battery compartment. **Make sure that the negative ends of the batteries (marked “-”) are touching the springs in the battery compartment.**

Connect the Reed Switch/Wire (50) and the two Pulse Grip Wires (60) to the corresponding wires on the Console (7). If your Console has a ground wire, attach it to the Handlebar Post (14) with an M4 x 16mm Screw (9).

Attach the Console (7) to the Handlebar Post (14) with four M4 x 12mm Console Screws (4). Next, press the Resistance Knob (10) onto the Resistance Control (11). Be sure that the mark on the Knob is correctly aligned.

- Press the Side Shield Cover (40) onto the Left and Right Side Shields (1, 2). Make sure that the four tabs (A) on the Side Shield Cover snap into the Side Shields.

Insert the Seat Post (20) into the Frame (15) and press the Seat Post Bushing (23) down into the Frame. Next, align one of the holes in the Seat Post with the hole in the Frame. Insert the Seat Knob (29) into the Frame and the Seat Post, and tighten the Seat Knob into the Frame. **Make sure to insert the Seat Knob through one of the holes in the Seat Post; do not insert the Seat Knob under the Seat Post.**

Attach the Seat (19) to the Seat Post (20) with four M8 Nylon Locknuts (21) and four M8 Split Washers (49). Note: The Nylon Locknuts and Split Washers may be pre-attached to the bottom of the Seat.

- Identify the Left Pedal (28) (there is an “L” on the Left Pedal for identification). Using an adjustable wrench, **firmly tighten** the Left Pedal counterclockwise into the left Crank Arm (33). **Firmly tighten** the Right Pedal (not shown) clockwise into the right Crank Arm. **After using the exercise cycle for one week, retighten the Pedals. For best performance, the Pedals must be kept tightened.**

Adjust the Left Pedal Strap (59) to the desired position and press the Pedal Strap onto the tab on the Left Pedal (28). Adjust the Right Pedal Strap (not shown) in the same way.

- Make sure that all parts are tightened before you use the exercise cycle. Note: There may be some hardware left over after assembly is completed.** Place a mat under the exercise cycle to protect the floor or carpet.

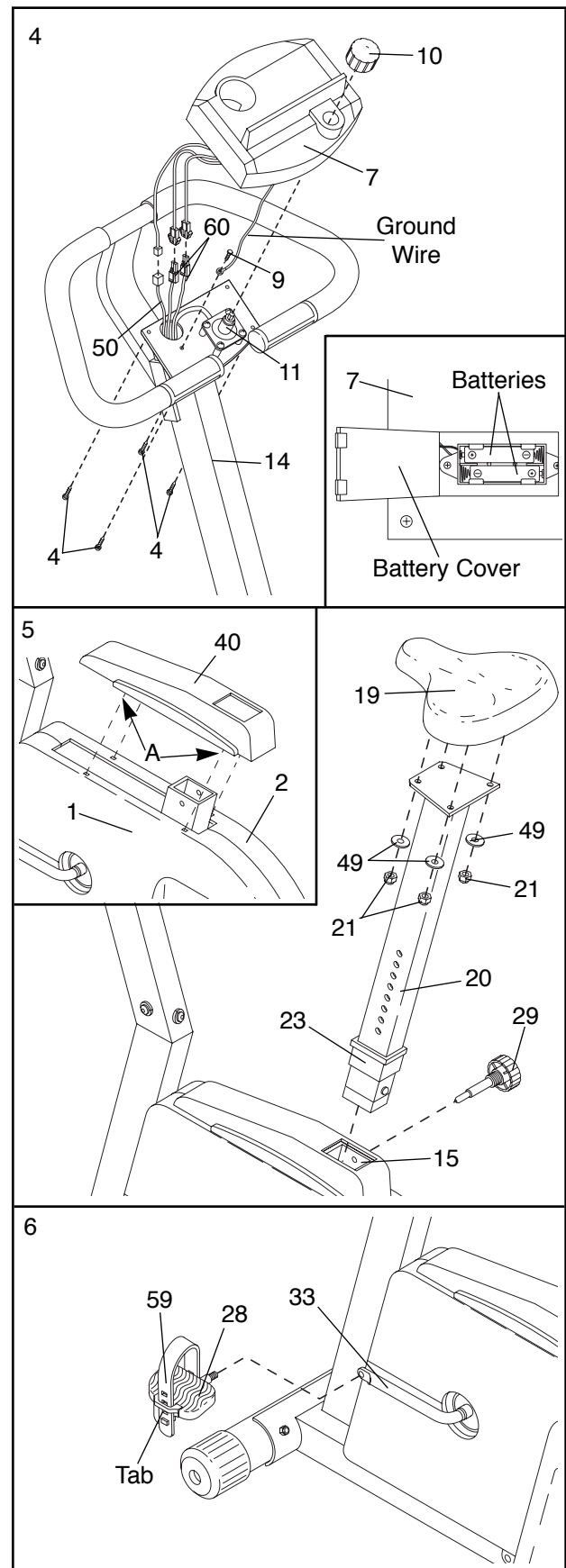

HOW TO USE THE 940s

HOW TO ADJUST THE SEAT

For effective exercise, the Seat (19) should be at the proper height. As you pedal, there should be a slight bend in your knees when the pedals are in the lowest position. To adjust the Seat, first hold the Seat and unscrew the Seat Knob (29).

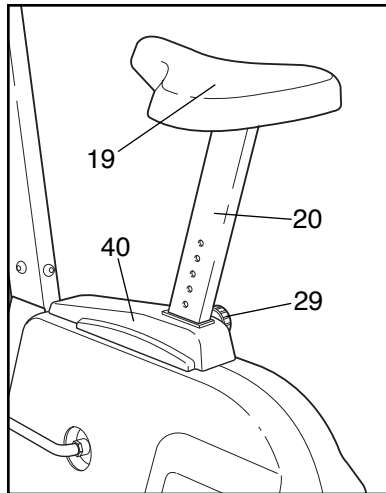

Align one of the holes in the Seat Post (20) with the hole in the Side Shield Cover (40). Insert the Seat Knob into the frame and the Seat Post, and tighten the Seat Knob into the frame. **Caution: Make sure to insert the Seat Knob through one of the holes in the Seat Post; do not insert the Seat Knob under the Seat Post.**

HOW TO ADJUST THE PEDALLING RESISTANCE

To vary the intensity of your exercise, the pedalling resistance can be adjusted. The resistance is controlled with the Resistance Knob (10). To increase the resistance, turn the Resistance Knob clockwise; to decrease the resistance, turn the Resistance Knob counterclockwise.

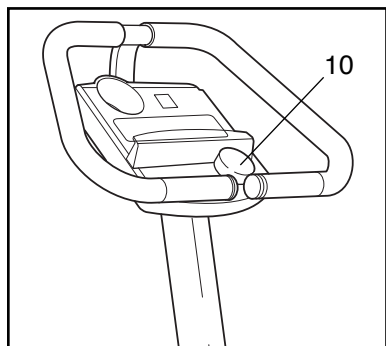





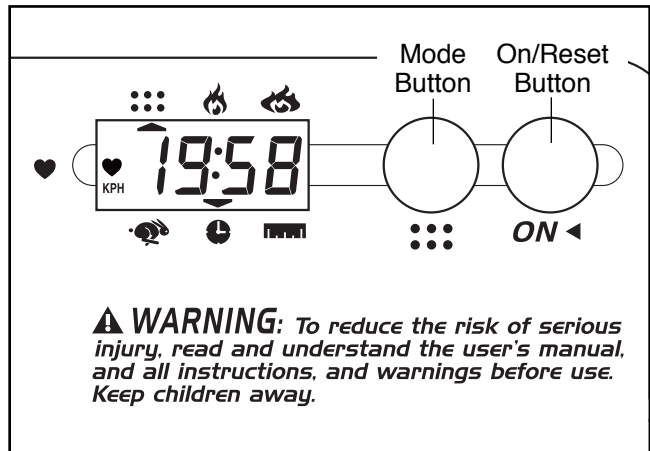

BATTERY INSTALLATION

Before the console can be operated, two “AA” batteries must be installed. If you have not installed batteries, see assembly step 4 on page 7.

DESCRIPTION OF THE CONSOLE



The innovative console features six modes that provide instant exercise feedback during your workouts. The modes are described below.

-  Speed—Displays your pedaling speed, in kilometers per hour.
-  Time—Displays the elapsed time. Note: If you stop pedaling for ten seconds or longer, the time mode will pause until you resume.
-  Distance—Displays the total distance you have pedaled, in kilometers.
-  Fat Calories—Displays the approximate number of fat calories you have burned. (See BURNING FAT on page 10.)
-  Calories—Displays the approximate number of calories you have burned.
-  Scan—Displays the speed, time, distance, fat calories, and calories modes, for 5 seconds each, in a repeating cycle.
-  Pulse—This mode shows your heart rate when the pulse sensor is used.

HOW TO OPERATE THE CONSOLE

Note: The console requires two “AA” batteries. See assembly step 4 on page 7 for battery installation instructions.

1. To turn on the power, press the on/reset button or simply begin pedaling. When the power is turned on, the entire display will appear for two seconds. The console will then be ready for operation.
2. Select one of the six modes:

Scan mode— When the power is turned on, the scan mode will automatically be selected. One mode arrow will show that the scan mode is selected, and a flashing mode arrow will show which mode is currently displayed. Note: If a different mode is selected, you can select the scan mode again by repeatedly pressing the mode button.

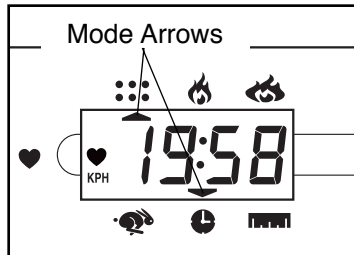

Speed, time, distance, fat calories, or calories mode— To select one of these modes for continuous display, press the mode button repeatedly. The mode arrows will show which mode is selected. Make sure that the scan mode is not selected.

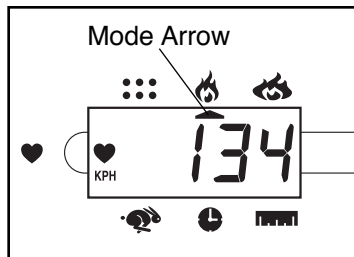

3. To reset the display, press the on/reset button.
4. To turn off the power, simply wait for about four minutes. **Note: The monitor has an “auto-off” feature. If the pedals are not moved and the monitor buttons are not pressed for four minutes, the power will turn off automatically in order to conserve the batteries.**

HOW TO USE THE PULSE SENSOR

Note: Before you can use the pulse sensor, you must peel the protective vinyl covering off the metal contacts on the top and bottom of the pulse sensor.

To use the pulse sensor, place your hands on the metal contacts. Your palms must be resting on the upper contacts and your fingers must be touching the lower contacts. **Avoid moving your hands.**

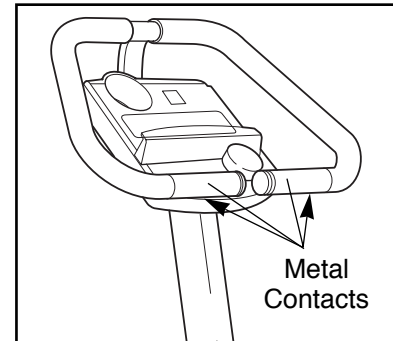

After a moment, the heart-shaped indicator in the display will begin to flash, three dashes (— — —) will appear and then your heart rate will be shown. For the most accurate heart rate reading, continue to hold the contacts for about 15 seconds.

Note: If your heart rate is not shown, press the reset button to reset the pulse sensor. In addition, make sure that your hands are positioned as described above. Be careful not to move your hands excessively or squeeze the metal contacts too tightly.

⚠ WARNING: The pulse sensor is not a medical device. Various factors, including the user's movement, may affect the accuracy of heart rate readings. The pulse sensor is intended only as an exercise aid in determining heart rate trends in general.

CONDITIONING GUIDELINES

The following guidelines will help you to plan your exercise program. Remember that proper nutrition and adequate rest are essential for successful results.

⚠ WARNING: Before beginning this or any exercise program, consult your physician. This is especially important for persons over the age of 35 or persons with pre-existing health problems.

EXERCISE INTENSITY

Whether your goal is to burn fat or to strengthen your cardiovascular system, the key to achieving the desired results is to exercise with the proper intensity. The proper intensity level can be found by using your heart rate as a guide. The chart below shows recommended heart rates for fat burning, maximum fat burning, and cardiovascular (aerobic) exercise.

165	155	145	140	130	125	115	♥
145	138	130	125	118	110	103	♥
125	120	115	110	105	95	90	♥
20	30	40	50	60	70	80	

To find the proper heart rate for you, first find your age on the bottom line of the chart (ages are rounded off to the nearest ten years). Next, find the three numbers above your age. The three numbers are your “training zone.” The lowest number is the recommended heart rate for fat burning; the middle number is the recommended heart rate for maximum fat burning; the highest number is the recommended heart rate for aerobic exercise.

To measure your heart rate, first exercise for at least four minutes. Then, stop pedalling and measure your heart rate using the pulse sensor. If you have any questions, see HOW TO USE THE PULSE SENSOR on page 9 of this manual.

Burning Fat

To burn fat effectively, you must exercise at a relatively low intensity level for a sustained period of time. During the first few minutes of exercise, your body uses easily accessible carbohydrate calories for energy. Only after the first few minutes of exercise does your body begin to use stored fat calories for energy. If your goal is to burn fat, adjust the intensity of your exercise until your heart rate is near the lowest number in your training zone as you exercise.

For maximum fat burning, adjust the intensity of your exercise until your heart rate is near the middle number in your training zone as you exercise.

Aerobic Exercise

If your goal is to strengthen your cardiovascular system, your exercise must be “aerobic.” Aerobic exercise is activity that requires large amounts of oxygen for prolonged periods of time. This increases the demand on the heart to pump blood to the muscles, and on the lungs to oxygenate the blood. For aerobic exercise, adjust the intensity of your exercise until your heart rate is near the highest number in your training zone.

WORKOUT GUIDELINES

Each workout should include the following three parts:

A warm-up, consisting of 5 to 10 minutes of stretching and light exercise. (See page 11.) A proper warm-up increases your body temperature, heart rate, and circulation in preparation for exercise.

Training zone exercise, consisting of 20 to 30 minutes of exercising with your heart rate in your training zone. (During the first few weeks of your exercise program, do not keep your heart rate in your training zone for longer than 20 minutes.)

A cool-down, with 5 to 10 minutes of stretching. This will increase the flexibility of your muscles and will help to prevent post-exercise problems.

EXERCISE FREQUENCY

To maintain or improve your condition, plan three workouts each week, with at least one day of rest between workouts. After a few months of regular exercise, you may complete up to five workouts each week, if

desired. **Caution: Be sure to progress at your own pace and avoid overdoing it. Incorrect or excessive training may result in injury to your health.**

Remember, the key to success is make exercise a regular and enjoyable part of your everyday life.

SUGGESTED STRETCHES

The correct form for several basic stretches is shown at the right. Move slowly as you stretch—never bounce.

1. Toe Touch Stretch

Stand with your knees bent slightly and slowly bend forward from your hips. Allow your back and shoulders to relax as you reach down toward your toes as far as possible. Hold for 15 counts, then relax. Repeat 3 times. Stretches: Hamstrings, back of knees and back.

2. Hamstring Stretch

Sit with one leg extended. Bring the sole of the opposite foot toward you and rest it against the inner thigh of your extended leg. Reach toward your toes as far as possible. Hold for 15 counts, then relax. Repeat 3 times for each leg. Stretches: Hamstrings, lower back and groin.

3. Calf/Achilles Stretch

With one leg in front of the other, reach forward and place your hands against a wall. Keep your back leg straight and your back foot flat on the floor. Bend your front leg, lean forward and move your hips toward the wall. Hold for 15 counts, then relax. Repeat 3 times for each leg. To cause further stretching of the achilles tendons, bend your back leg as well. Stretches: Calves, achilles tendons and ankles.

4. Quadriceps Stretch

With one hand against a wall for balance, reach back and grasp one foot with your other hand. Bring your heel as close to your buttocks as possible. Hold for 15 counts, then relax. Repeat 3 times for each leg. Stretches: Quadriceps and hip muscles.

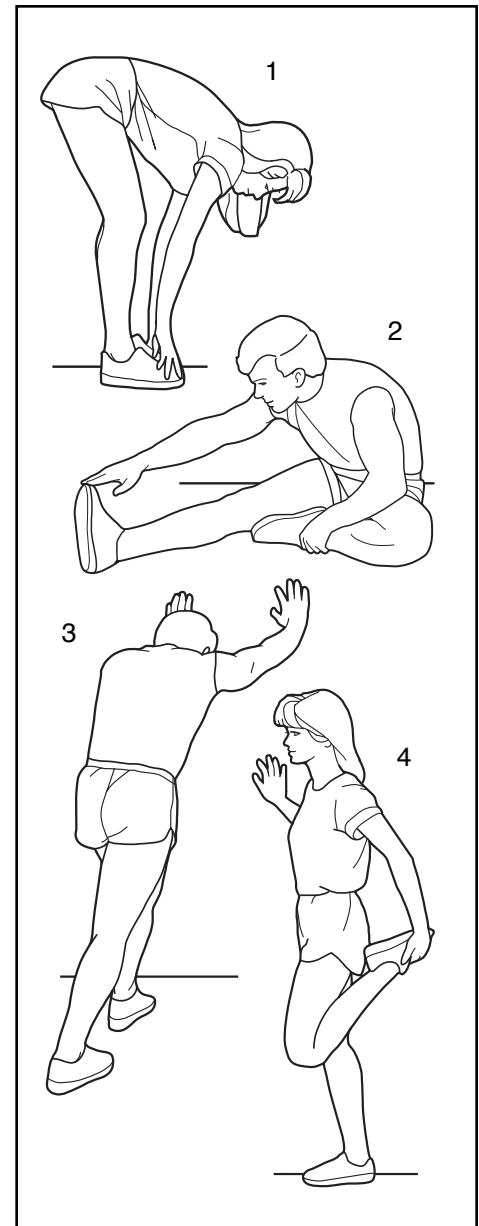

MAINTENANCE AND TROUBLE-SHOOTING

Inspect and tighten all parts of the exercise cycle regularly. Replace any worn parts immediately.

The exercise cycle can be cleaned with a soft, damp cloth. Avoid spilling liquid on the console. Keep the console out of direct sunlight or the display may be damaged. Remove the batteries when storing the exercise cycle.

HOW TO TIGHTEN THE CRANK

If the arms of the Crank (33) become loose, they should be tightened in order to prevent excessive wear. Loosen the crank nut on the left arm of the Crank. Place the end of a standard screwdriver in one of the slots in the slotted crank nut. Lightly tap the screwdriver with a hammer to turn the slotted crank nut counterclockwise until the arms are no longer loose. **Do not overtighten the slotted crank nut.** When the slotted crank nut is properly tightened, retighten the crank nut.

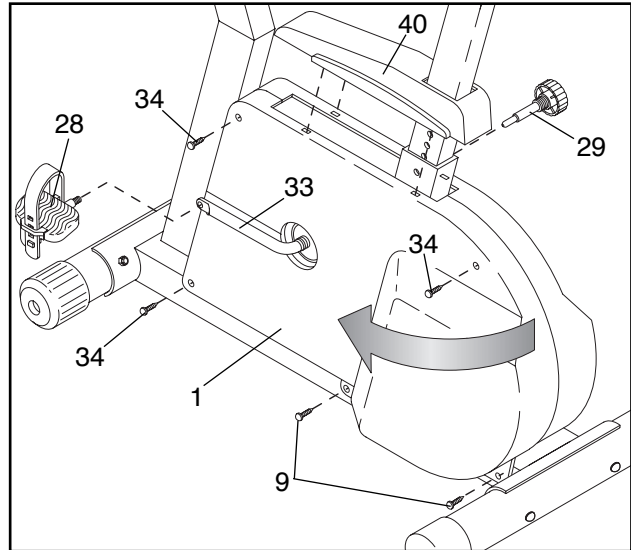
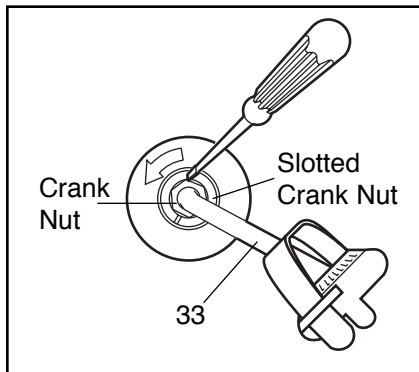

Next, remove the Seat Knob (29) and lift the Side Shield Cover (40) off the Side Shields. Grasp both Side Shields at the top and gently pull them apart. Make sure that the arm of the Crank (33) is in the position shown in the drawing above. Carefully slide the Left Side Shield forward off the arm of the Crank and remove it.

Locate the Reed Switch (50). Turn the Crank (33) until the Magnet (51) is aligned with the Reed Switch. Loosen but do not remove the M4 x 16mm Screw (9). Slide the Reed Switch slightly closer to or away from

BATTERY REPLACEMENT

If the console does not function properly, the batteries should be replaced. To replace the batteries, see assembly step 4 on page 7. In addition, make sure that the console wire is connected to the reed switch wire.

HOW TO ADJUST THE REED SWITCH

If the console does not display correct feedback, the reed switch should be adjusted. In order to adjust the reed switch, the Left Side Shield (1) must be removed (refer to the drawing at the top of this page). Using an adjustable wrench, turn the Left Pedal (28) clockwise and remove it from the Crank (33). Remove the two M4 x 16mm Screws (9) and three M4 x 38mm Self-tapping Screws (34) from the Left Side Shield.

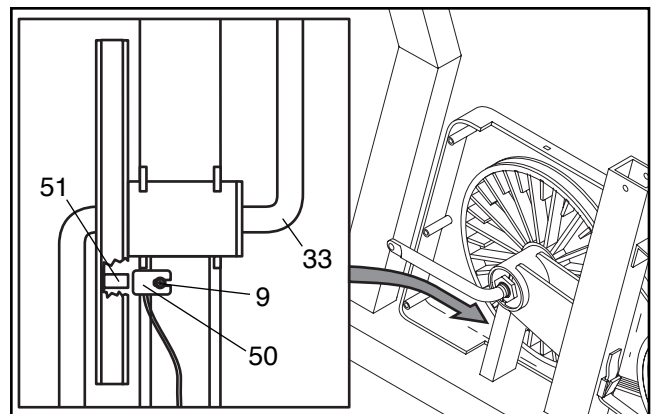

the Magnet. Retighten the Screw. Turn the Crank for a moment. Repeat until the console displays correct feedback. When the Reed Switch is correctly adjusted, reattach the Left Side Shield and Pedal.

HOW TO ADJUST THE BELT

The exercise cycle features a precision belt that must be kept properly adjusted. If the belt causes excessive noise or slips as you pedal, the belt should be checked. To do this, the left side shield must first be removed. Refer to the instructions on page 12 and remove the left side shield.

Next, use an adjustable wrench to turn the right pedal counterclockwise and remove it. Remove the right side shield.

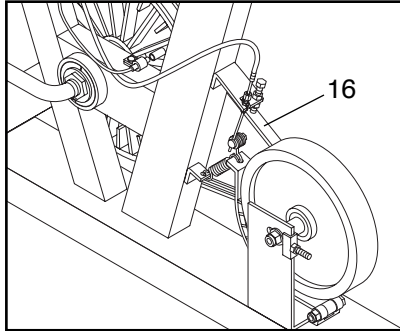

Press down on the center of the Belt (16) between the front and rear sprockets. **There should be from 1/4" to 3/4" of vertical movement in the center of the Belt.**

If the Belt (16) is properly adjusted, reattach the side shields and pedals. If the Belt needs to be adjusted, loosen the M8 Washer Nut (37) on each side of the Flywheel (32).

To tighten the Belt, turn the two M6 Stop nuts (47) clockwise; to loosen the belt, turn the Nuts counterclockwise. Make sure that the Flywheel is straight and tighten the M8 Washer Nuts (37). Reattach the side shields and pedals.

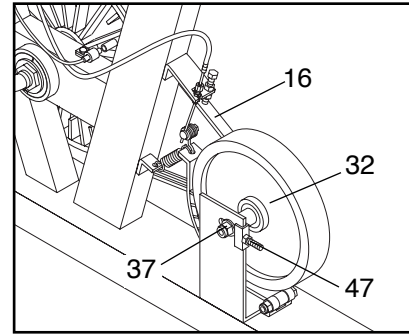

PART LIST—Model No. 831.288070

R0200A

Key No.	Qty.	Description	Key No.	Qty.	Description
1	1	Left Side Shield	33	1	Crank/Pulley
2	1	Right Side Shield	34	3	M4 x 38mm Self-tapping Screw
3	2	Double Tree Fastener	35	1	Flywheel Spacer
4	4	M4 x 12mm Console Screw	36	1	Flywheel Axle
5	1	Handlebar	37	2	M8 Washer Nut
6	2	Foam Grip	38	2	M6 Eye Bolt
7	1	Console	39	2	Adjustment Bracket
8	5	M10 x 25mm Button Screw	40	1	Side Shield Cover
9	8	M4 x 16mm Screw	41	7	M10 Split Washer
10	1	Resistance Knob	42	1	Bearing Assembly
11	1	Resistance Control/Cable	43	1	“C” Magnet Spring
12	3	M5 x 30mm Screw	44	2	Stabilizer Endcap
13	1	Right Pedal	45	1	“C” Magnet
14	1	Handlebar Post	46	1	M6 x 64mm Bolt
15	1	Frame	47	4	M6 Stop Nut
16	1	Belt	48	1	M8 x 62mm Bolt
17	1	Front Stabilizer	49	4	M8 Split Washer
18	1	Rear Stabilizer	50	1	Reed Switch/Wire
19	1	Seat	51	1	Magnet
20	1	Seat Post	52	2	Pulse Grip
21	9	M8 Nylon Locknut	53	1	Clamp Bolt
22	1	25.4mm x 63.5mm Bushing	54	4	1/4” Flat Washer
23	1	Seat Post Bushing	55	1	“S” Hook
24	2	Wheel Hub	56	1	Clamp Nut
25	2	Wheel	57	1	Reed Switch Clamp
26	2	Wheel Spacer	58	1	Right Pedal Strap
27	2	M6 x 16mm Self-tapping Screw	59	1	Left Pedal Strap
28	1	Left Pedal	60	2	Pulse Grip Wire
29	1	Seat Knob	61	3	M5 Nut
30	4	M8 x 90mm Carriage Bolt	#	1	Allen Wrench
31	1	M10 Flat Washer	#	1	User’s Manual
32	1	Flywheel			

Note: “#” indicates a non-illustrated part. Specifications are subject to change without notice.

EXPLODED DRAWING—Model No. 831.288070

R0200A

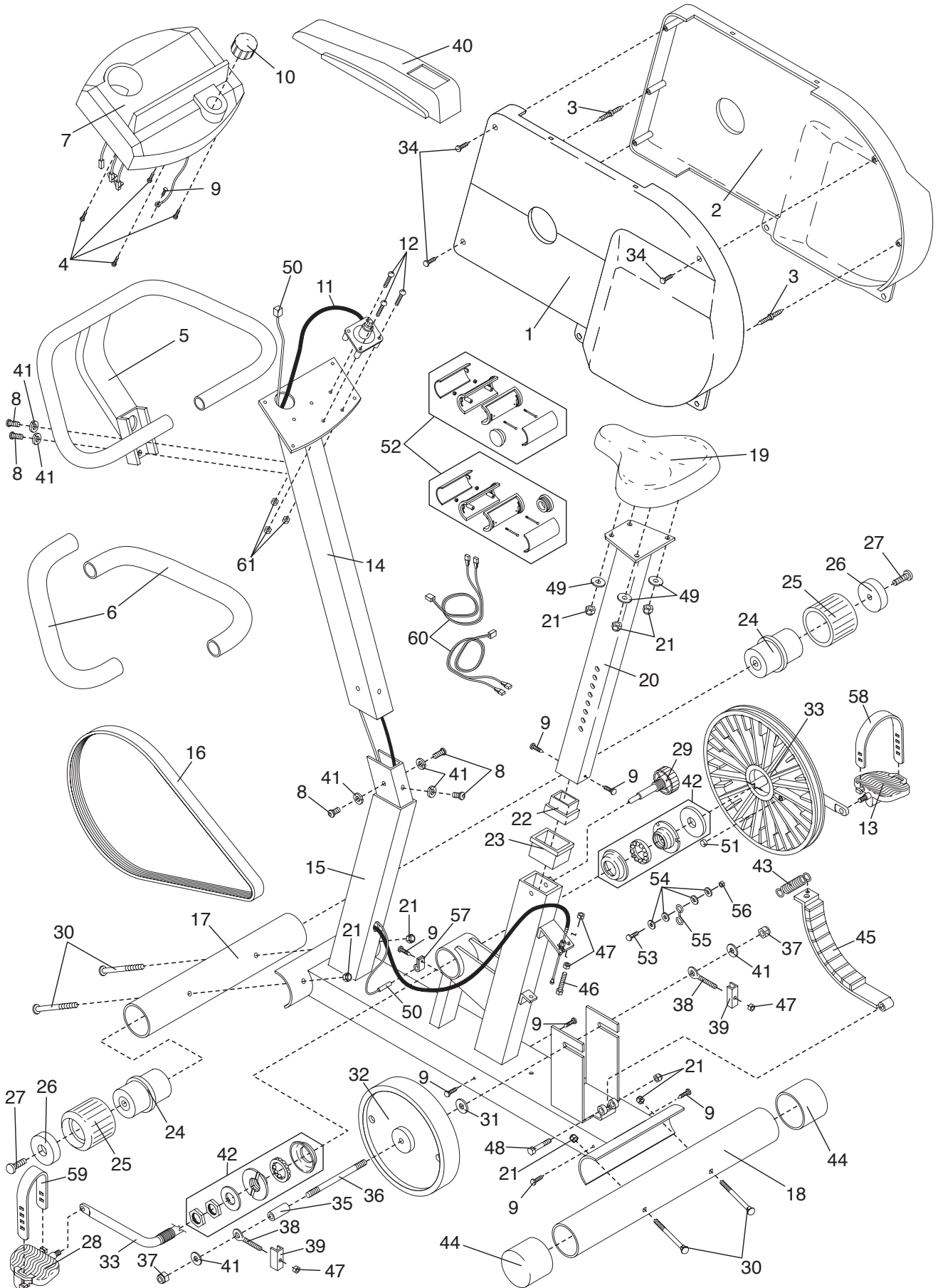

HOW TO ORDER REPLACEMENT PARTS

To order replacement parts, call our Customer Service Department toll-free at 1-800-999-3756, Monday through Friday, 6 a.m. until 6 p.m. Mountain Time (excluding holidays). To help us assist you, please be prepared to give the following information:

- The MODEL NUMBER of the product (831.288070)
- The NAME of the product (PROFORM® 940s exercise cycle)
- The SERIAL NUMBER of the product (see the front cover of this manual)
- The KEY NUMBER and DESCRIPTION of the part(s) (see the PART LIST on page 14 of this manual).

PROFORM is a registered trademark of ICON Health & Fitness, Inc.

LIMITED WARRANTY

ICON Health & Fitness, Inc. (ICON), warrants this product to be free from defects in workmanship and material, under normal use and service conditions, for a period of ninety (90) days from the date of purchase. This warranty extends only to the original purchaser. ICON's obligation under this warranty is limited to replacing or repairing, at ICON's option, the product through one of its authorized service centers. All repairs for which warranty claims are made must be pre-authorized by ICON. This warranty does not extend to any product or damage to a product caused by or attributable to freight damage, abuse, misuse, improper or abnormal usage or repairs not provided by an ICON authorized service center, products used for commercial or rental purposes, or products used as store display models. No other warranty beyond that specifically set forth above is authorized by ICON.

ICON is not responsible or liable for indirect, special or consequential damages arising out of or in connection with the use or performance of the product or damages with respect to any economic loss, loss of property, loss of revenues or profits, loss of enjoyment or use, costs of removal, installation or other consequential damages of whatsoever nature. Some states do not allow the exclusion or limitation of incidental or consequential damages. Accordingly, the above limitation may not apply to you.

The warranty extended hereunder is in lieu of any and all other warranties and any implied warranties of merchantability or fitness for a particular purpose is limited in its scope and duration to the terms set forth herein. Some states do not allow limitations on how long an implied warranty lasts. Accordingly, the above limitation may not apply to you.

This warranty gives you specific legal rights. You may also have other rights which vary from state to state.

ICON HEALTH & FITNESS, INC., 1500 S. 1000 W., LOGAN, UT 84321-9813