

# PRECOR<sup>®</sup> USA 718e

## Low Impact Climber with Pulse\*

\*Several versions of this owner's manual exist. This is a copy of the last version published. If the assembly instructions do not coincide with your 718e, please call Precor Customer Service.

## Owner's Manual Assembly and Operation

# PRECOR<sup>USA</sup> 718e

## Low Impact Climber with Pulse

***CAUTION: Before beginning any fitness program, you should have your physician give you a complete physical examination.***

Thank you for purchasing the Precor 718e or 723e Low Impact Climber with Pulse. The pulse feature lets you view your pulse rate on the display when you use the Precor pulse detector (ear clip option) or the Precor Heart Rate Option.

The smooth, quiet motion of the stair arms lets you focus on your workout without the noise and distractions other climbing machines have. Multiple resistance settings let different users set the machine to their workout demands and allow workload to be raised and lowered within a single session. The unique handrails offer a number of handhold positions to lend variety to a workout. The low-impact exercise tones all the muscles in the lower body while helping to build your cardiovascular fitness level.

The 718e Low Impact Climber provides microprocessor-controlled electronics which let you monitor your progress and keep your workouts interesting.

### Safety Information

Please review and observe the following safety guidelines:

- Read the Owner's Manual and follow all instructions.
- Assemble and operate the climber on a solid, level surface.
- Never allow children on or near the climber.
- Check the climber before each use. Do not use the climber if it is not completely assembled or is damaged in any way.
- Keep hands away from moving parts.
- Be aware that the weight limit for the climber is 250 pounds.
- Wear proper exercise clothing and shoes for your workout—no loose clothing. Do not wear shoes with heels or leather soles. Check the soles of your shoes and remove any dirt and embedded stones. Tie long hair back.
- Use care when getting on or off the climber. Do not rock the unit. Do not stand or climb on the handrails and electronic console.
- Do not use accessory attachments that are not recommended by the manufacturer—such attachments might cause injuries.
- Be aware that, under extended continuous use, the resistance cylinders on the climber can heat up to the point of being uncomfortable to touch.
- Do not overexert yourself or work to exhaustion.
- Stop your workout immediately if you feel any pain or abnormal symptoms, and consult your physician.

# Table of Contents

<b>Unpacking the 718e Low Impact Climber</b> . . . . .	4
<b>Assembling the 718e Low Impact Climber</b> . . . . .	6
Installation Requirements . . . . .	6
Assembly Instructions . . . . .	6
<b>Using the Precor 718e Low Impact Climber</b> . . . . .	16
Understanding the Electronic Console . . . . .	16
Displays . . . . .	16
Keys . . . . .	17
Setting the Resistance Level . . . . .	18
Setting a Pacer . . . . .	19
Using the Pulse Feature . . . . .	19
Pausing Your Workout . . . . .	20
Ending a Workout . . . . .	20
How to Use the 718e Climber . . . . .	20
Working Out on the 718e Climber . . . . .	20
Sample Exercise Routines . . . . .	22
<b>General Aerobic Training Information</b> . . . . .	23
How Hard Should I Exercise? . . . . .	24
How Long Should I Exercise? . . . . .	25
How Often Should I Exercise? . . . . .	25
<b>Maintenance and Troubleshooting</b> . . . . .	26
Cleaning the Climber . . . . .	26
Changing the Batteries . . . . .	26
Troubleshooting Tips . . . . .	27
Obtaining Service . . . . .	27

## Unpacking the 718e Low Impact Climber

All Precor products are thoroughly tested and inspected before shipment. The 718e Low Impact Climber is shipped in the following pieces:

- base
- upright support (long column)
- base column support (short column)
- resistance cylinders
- handrail console
- electronic console display
- hardware kit, Owner's Manual, and limited warranty card (not shown in Diagram 1)

### Diagram 1

Unpacking the climber

Upright support (long column)

Base column support (short column)

Base

Electronic console display

Resistance cylinders

Handrail consoles

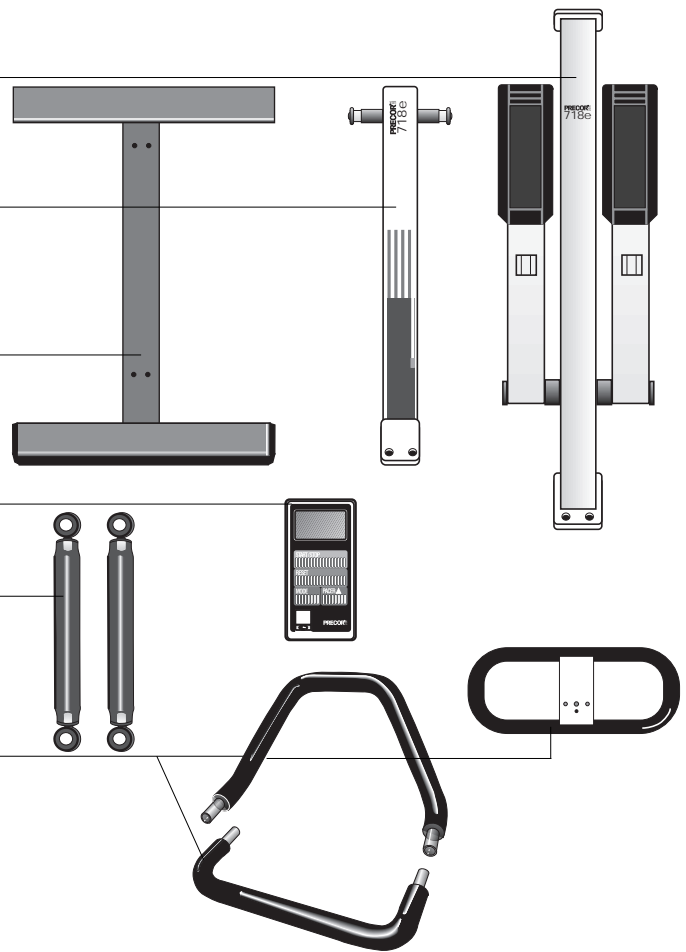

Unpack the climber and place all the pieces on the floor. For help in identifying the various pieces, refer to Diagram 1. The packet containing the hardware kit, Owner's Manual, and limited warranty card is not shown.

**Important:** Do not pinch or crimp the reed switch cable during the unpacking and assembly process. The rope attached to the 718e upright assembly is used to install the reed switch cable. **Do not remove the rope from the 718e upright assembly at this time. Do not cut the wire ties holding the stair arms to the upright support.**

**Diagram 2**  
718e Hardware kit

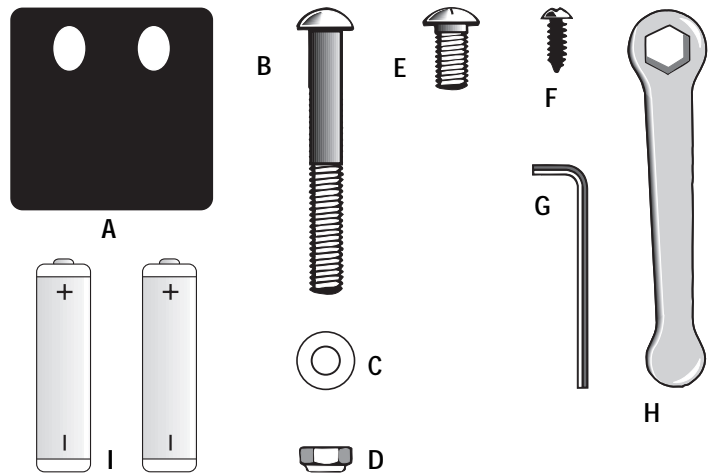

Open the hardware kit and identify the following items. Diagram 2 provides an overview of the kit's contents. As you identify the contents of the kit, check them off below:

- (A) Two gaskets for frame base
- (B) Four frame-to-base bolts
- (C) Four large flat washers
- (D) Four lock nuts
- (E) Two small bolts
- (F) Two Phillips-head screws
- (G) One 3/16" hex key
- (H) One 1/2" wrench
- (I) Two AA batteries

If any items are missing, contact your authorized Precor dealer. For the dealer nearest you, call 1-800-4-PRECOR.

## Assembling the 718e Low Impact Climber

The information in this section provides instructions regarding the assembly of the 718e or 723e Low Impact Climber. You should carefully read and follow the instructions in this manual. If you do not assemble and use the climber according to the following guidelines, you could void the Precor limited warranty.

### Installation Requirements

Follow these installation requirements when installing the climber:

- **Set up the 718e climber on a solid, flat surface.**
- **Fill out and mail the limited warranty registration card.** The serial number is located on the underside of the climber's base. It is also located on a label on the outside of the box.

### Assembly Instructions

To assist you in the assembly of the 718e climber, the items in the hardware kit, shown in Diagram 2, correspond to a particular letter in the alphabet. These letters appear throughout the assembly instructions. Refer to Diagram 2 while performing the steps below.

**Note:** You will need a scissors and a phillips-head screwdriver to complete the assembly process.

**Diagram 3**

Place frame on base

Upright support

Stair arm

Front crossbar

Blocks or books

Base

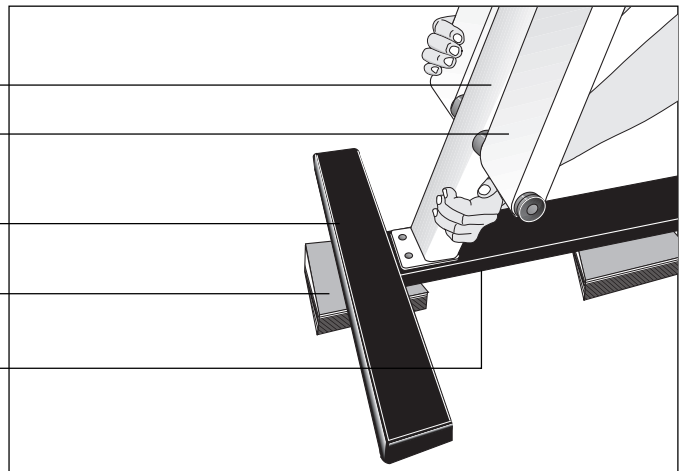

1. **Place Upright Support on Base.** (Diagram 3) To install the upright support (long column that has the stair arms attached) take the following steps:

**Important:** Do not remove the red rope from the upright support. It is used to feed the reed switch cable through the upright support.

- a. Place the base at or near the location where you will be using the climber. Lift the base onto wooden blocks or large hardcover books. This helps you access the underside of the base. Make sure that the rubber pads on the crossbar are facing the floor.
- b. Position the upright support (long column) onto the base.

**Note:** Be sure to align the upright support and base properly. The front crossbar and upright support mounts are very close together as shown in Diagram 3.

- c. Remove a gasket (A) from the hardware kit. Align the upright support with the mounting holes in the base. Place the gasket between the upright support mount and base.

**Diagram 4**

Attach frame to base

- Upright support
- Washer
- Gasket
- Bolt
- Weld
- Base
- Front crossbar

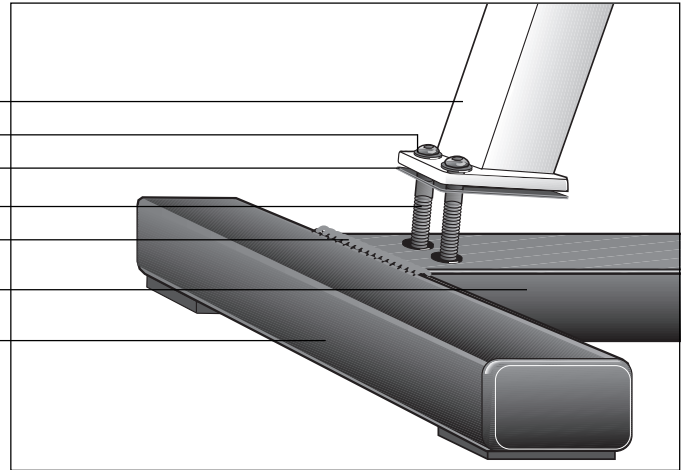

- d. Take two frame-to-base bolts (B) from the hardware kit and place a washer (C) on each. Insert the bolts through the upright support mount, gasket, and base. Make sure that the front mount is adjacent to the crossbar weld, but not on top of the weld. See Diagram 4. Attach a lock nut (D) to the opposite end of each bolt. Hold the lock nut with the socket wrench while you firmly tighten the bolts with the hex key (G) provided.

**Important:** Perform the following step on one stair arm at a time.

- e. Hold onto the stair arm's footpad with one hand while you use scissors (in the other hand) to cut the plastic wire tie that secures the stair arm to the upright support. Carefully lower the stair arm onto the rear crossbar. Perform the same step for the other stair arm.

**Note:** If the upright support is mounted properly, the stair arms rest on the *rear* crossbar.

**CAUTION:** To avoid injury and ensure the integrity of the unit, do not drop the stair arm onto the rear crossbar.

**Diagram 5**

Pull reed switch cable through upright support

Rope

Upright support

Reed switch cable connector

Reed switch cable

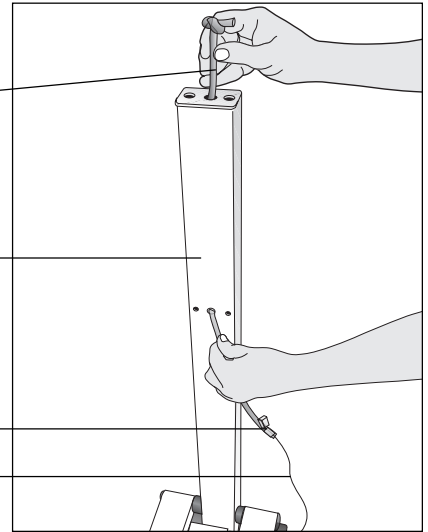

2. **Feed Reed Switch Cable through Upright Support.** (Diagram 5) Remove the bolts from the base column support (short column) and set them aside. The gasket should hang on the reed switch cable. Take the following steps to install the reed switch cable:
  - a. Cut the wire tie from around the reed switch cable and gently pull the cable out of the roller guard. Place the short column near the upright support so that the gasket and roller guard face the red rope.
  - b. Ask an assistant to hold the base column support. This lets you have both hands free to manipulate the rope and cable.
  - c. Securely tape the reed switch cable connector to the *end* of the red rope and feed the cable through the upright support (long column) as you carefully pull the rope out from the top. Tape the reed switch cable to the top of the upright support and set the rope aside for use in step 12.

**Note:** You may need to tip the climber onto its side if the cable disengages from the rope. A hex key is helpful in locating the cable inside the column and in pulling it through the hole at the top.



**Diagram 6**

Attach base column support to upright support

Reed switch cable connector

Upright support

Gasket

Base column support (short column)

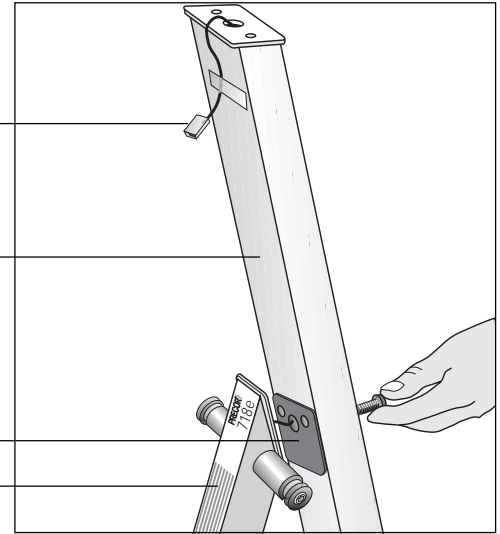

**CAUTION:** Make sure you do not crimp the reed switch cable when you tighten the base column support onto the upright support because you could void the manufacturer's limited warranty.

3. **Secure Upper Frame Pieces Together.** (Diagram 6) Gently pull the reed switch cable from the top of the upright support as you align the bolt holes in the upright support with the base column support and gasket. Insert the two mid-frame bolts that you set aside in step 2. Thread the bolts through the upright support and into the short column. Fully tighten the bolts using the hex key (G) provided, but be careful not to pinch the cable.

**Diagram 7**

Install base column support to base frame

Base column support (short column)

Washer

Base column support mount

Gasket

Bolt

Rear crossbar

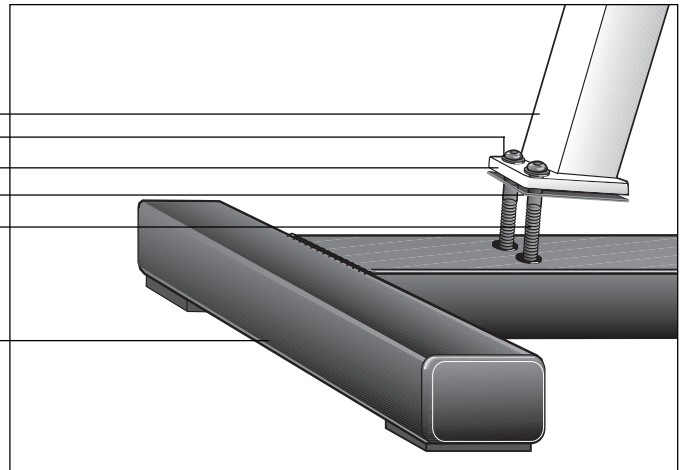

4. **Attach Base Column Support to Base.** (Diagram 7) Place a washer (C) onto each of the two remaining frame-to-base bolts. Place the remaining gasket between the base column support mount and the base frame. Align the holes and insert the bolts and washers through the base column support mount and the climber base. Attach a lock nut (D) to the end of each bolt. Hold the lock nut with the wrench (H) while you firmly tighten the bolts with the hex key (G) provided.

**Diagram 8**

Attach resistance cylinder to upright support

Upper axle

Spacer

Washer

Bolt

Upright support

Adjustment portion

Resistance cylinder

Indicator arrow

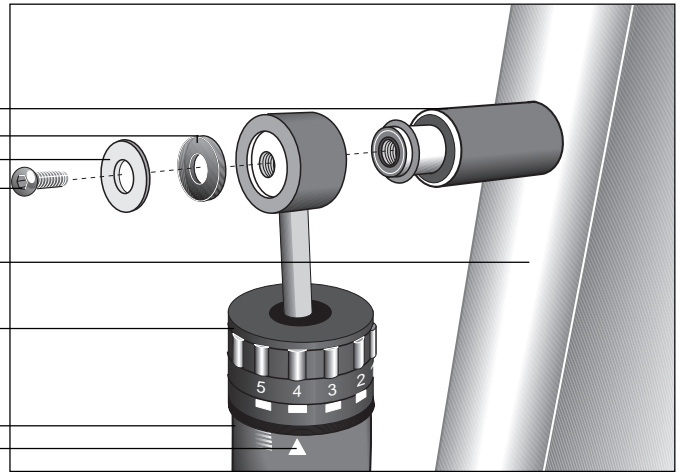

5. **Attach Resistance Cylinders to Upright Support.** (Diagram 8) Remove the bolt, washer and spacer from the upper axle using your fingers or the hex key (G) provided. With the indicator arrow facing toward the footpad, slide the top of the resistance cylinder onto the upper axle. Place the washer and spacer on the bolt. Re-insert the bolt and tighten securely using the hex key provided. Repeat this same step to attach the other resistance cylinder.

**Diagram 9**

Remove bolts from lower resistance cylinder mounts

Bolt

Washer

U-shaped mount

Nut

Stair arm

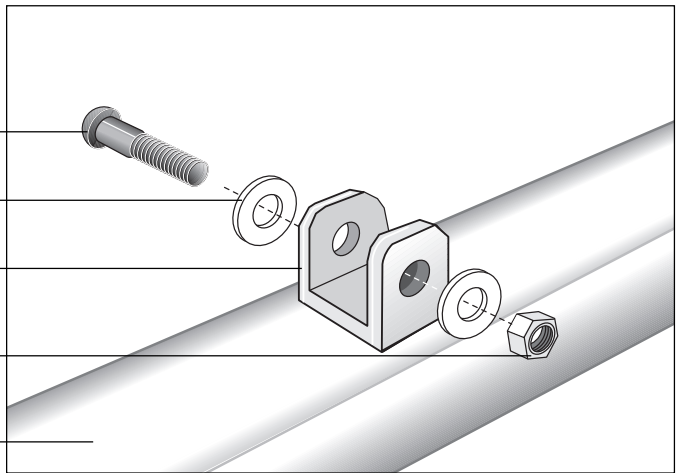

6. **Connect Resistance Cylinders to Stair Arms.** (Diagrams 9 and 10) The washers, nut, and bolt need to be removed from the lower resistance cylinder mount (U-shaped mount) before connecting the resistance cylinders. See Diagram 9. Remove the bolt using your fingers or the supplied hex key (G). To mount the lower resistance cylinders to the stair arms, take the following steps:

**Note:** Perform the following steps on one stair arm at a time.

**Diagram 10**  
Attach resistance cylinder to stair arm

Bolt  
Washer  
Resistance cylinder mount  
Bushing  
U-shaped mount  
Nut  
Stair arm

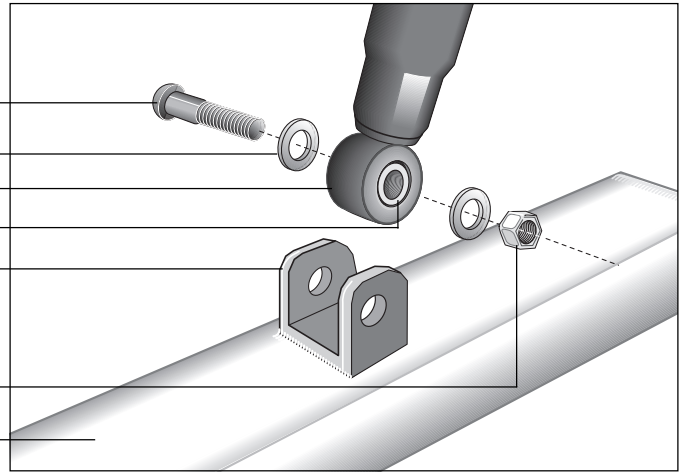

- a. Align the resistance cylinder with the holes in the U-shaped mount and slide the resistance cylinder into position. See Diagram 10.
- b. Insert the bolt through the U-shaped mount and resistance cylinder as shown in Diagram 10. Use the wrench to hold the nut in place while you tighten the bolt securely.
- c. Repeat step 6 to mount the other resistance cylinder.

**Diagram 11**  
Install handrail

Bolt  
Reed switch cable  
Handrail console  
Handrail  
Upright support

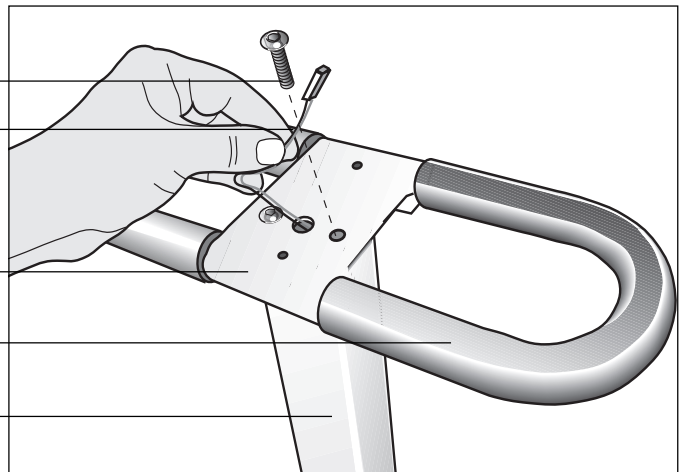

**CAUTION:** *The reed switch cable should slide easily through the upright support. Do not tug on the cable because you could void the manufacturer's limited warranty.*

7. **Install Handrail.** (Diagram 11) Take the two small bolts from the hardware kit. Position the handrail console (flat surface of the console should face up) on top of the upright support and feed the reed switch cable through the large hole in the handrail console. Tape the connector to the top of the console. Align the bolt holes and secure the handrail console to the frame by inserting the bolts through the top of the handrail console and into the upright support. Tighten the bolts firmly using the hex key (G).

**Important:** Pull gently on the excess cable as you feed the cable through the large hole in the handrail console. If the cable does not move freely, check to be sure that the cable is not pinched or crimped between the long and short column mounts. See step 3.

**Diagram 12**  
Install electronic console

Electronic console

Phillips-head screws

Handrail console

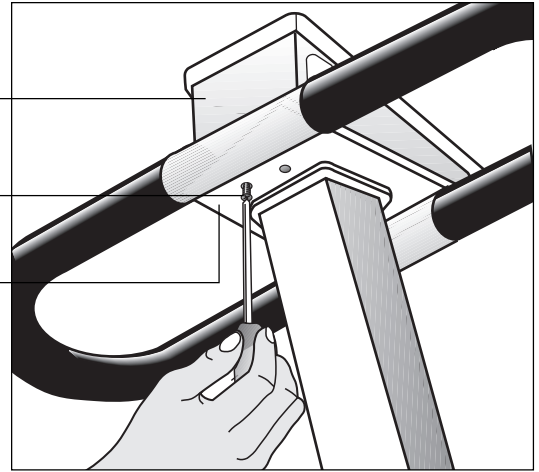

8. **Install Electronic Console.** (Diagram 12) To attach the electronic console display to the handrail console, take the following steps:
  - a. Plug the slotted reed switch cable connector into its receptacle on the underside of the electronic console display.
  - b. Place the electronic console display on the handrail console while you gently feed any excess cable back through the hole in the handrail console.
  - c. Align the holes and insert two phillips-head screws (F) on the underside of the handrail console.
  - d. Tighten the screws using your phillips-head screwdriver.

**CAUTION:** Make sure you do not crimp the reed switch cable when you tighten the base column support onto the upright support because you could void the manufacturer's limited warranty.

**Diagram 13**  
Install the batteries

AA battery case

Battery drawer

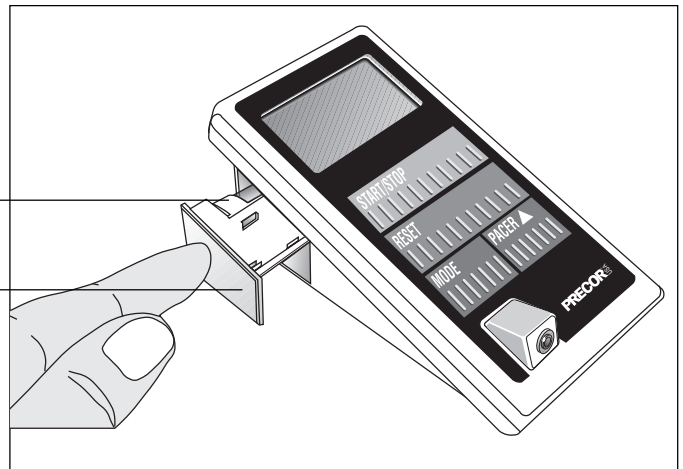

9. **Insert Batteries.** (Diagram 13) Find the drawer on the side of the electronic console and press in lightly to open it. Pull the drawer out with your fingers. Take the following steps to insert the batteries:
  - a. Slide the drawer out to expose the battery case. Place the two "AA" alkaline batteries (found in the hardware kit) into the case. Align the batteries to the proper polarity (+ and - indicators are inside the battery case). The entire display lights and the console beeps.
  - b. Close the battery drawer by pushing it gently into the electronic console.
  - c. Press START/STOP to activate the timer (TIME display). Press RESET to "reset" the displays to zero. For more information, refer to the section titled, *Understanding the Electronic Console*.

**Diagram 14**  
Location of magnet and reed switch

- Resistance cylinder
- Base column support
- Left-hand stair arm
- Magnet
- Reed switch
- Gap 1/8" to 1/4"  
(.05 to .1 centimeters)

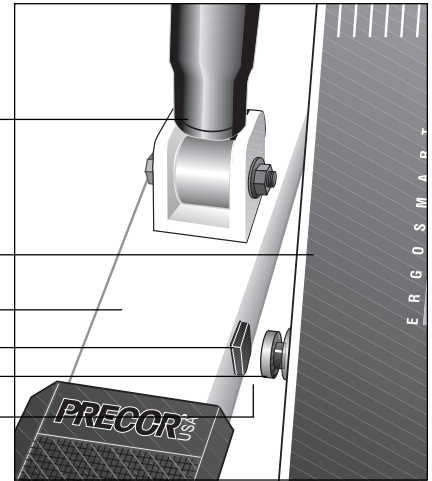

10. **Check Operation of Electronics.** (Diagram 14) Make sure that the spacing between the magnet on the left stair arm and the reed switch on the rear short column is correct. If the spacing is incorrect, the electronic console display will not operate properly. The distance between the magnet and the reed switch should be about 1/8 inch (.05 centimeters). If the spacing is not correct, adjust the spacing by moving the reed switch in or out of the column with your fingers.
11. **Set the Resistance.** Adjust the stair arm resistance by turning the top of the resistance cylinder until the triangle on the resistance cylinder points to the "2" on the adjustment knob. Do the same for the other stair arm. Make sure that the resistance on both stair arms is at the same setting.

**Diagram 15**  
Align stair arms with label

- Rope
- Precor label' red box
- Stair arm footpad
- Rear crossbar

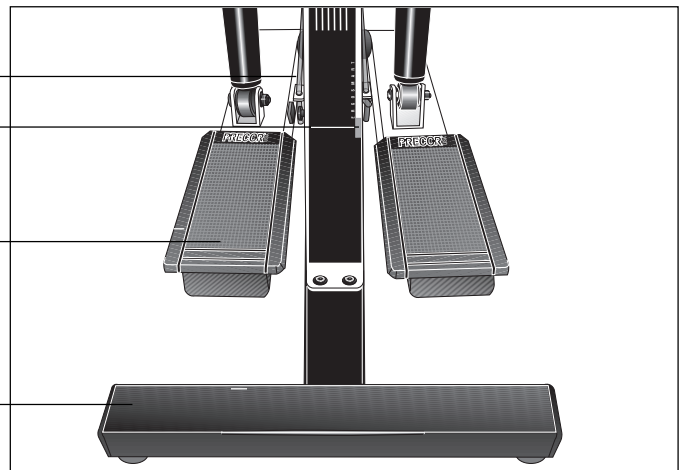

12. **Install Rope.** (Diagram 15 and 16) To properly install the rope (set aside in step 2), get a marker (pen or pencil) and take the following steps:
  - a. Feed the rope up through the right stair arm mount. (Determine right and left while standing behind the rear crossbar and facing toward the electronic console.)
  - b. Move both stair arms so that the *top* of the stair arms line up with the red box located on the Precor label. See Diagram 15. Have an assistant hold the stair arms in place while you route the rope through the pulley.

**Note:** It may be easier to install the guide rope if the climber is placed on its right hand side on the floor. This will expose the underside of the stair arms and provide easier accessibility.

**Diagram 16**

Install the guide rope

Pulley

Finger guard

Stair arm

Right stair arm mount

Guide rope

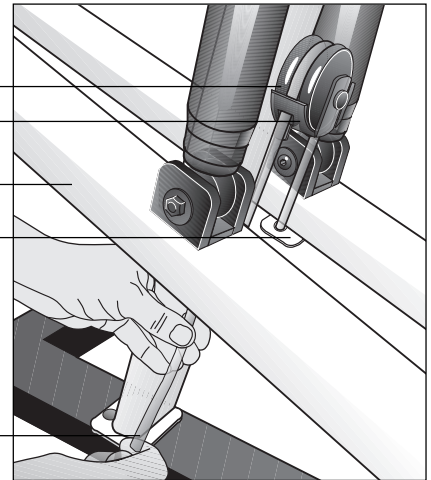

- c. Loop the rope over the pulley (through the finger guard on both sides of the pulley) and down into the left stair arm mount. See Diagram 16.

**Diagram 17**

Mark the guide rope

Guide rope

Pencil or pen mark

Left stair arm mount

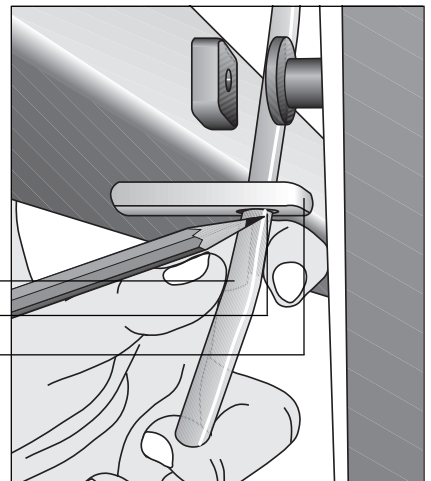

**CAUTION:** Do not stand on the stair arms while performing these steps. Prior to working out, the tension on the guide rope must be set properly to avoid damaging the resistance cylinders and voiding the manufacturer's limited warranty.

**CAUTION:** Check the knots and the length of the rope before standing on the stair arms. You cannot re-tie the knots once you stand on the stair arms.

- d. Pull the rope taut and mark the rope where it meets the stair arm mount. See Diagram 17.  
**Important:** Before you mark the rope, be sure that the top of both stair arms line up with the top of the red box on the Precor label. Refer to Diagram 15 on page 13.
- d. With the rope running through the stair arm mount, move both stair arms up so that you can easily tie a knot where you marked the rope. Note that if you placed the climber on its side to install the rope, return the climber to an upright position with the base flat on the floor.
- e. Check the length of the guide rope by returning the stair arms to an even position shown in Diagram 15 on page 13. The top of both stair arms should line up with the red box located on the Precor label.
- f. Step onto the stair arms. Test the stair stroke by moving your legs up and down a few times.

**Diagram 18**

Measure the distance of the resistance cylinders from the mounts

Adjustment knob  
Resistance cylinder mount

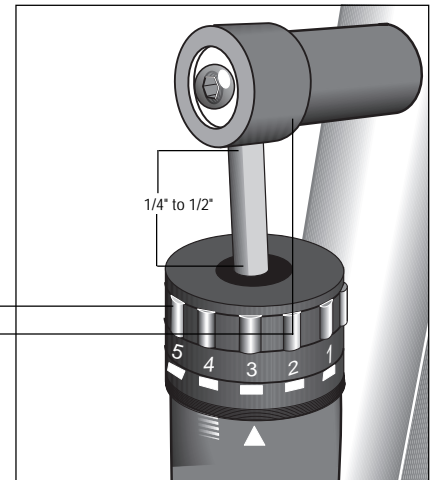

- g. Press the right footpad down onto the rear crossbar. Let the left stair arm move up into its highest position (away from the rear crossbar). Check the distance between the top of the resistance cylinder on the left stair arm and the upper axle. It should be between 1/4 to 1/2 inches (.1 to .2 centimeters). See Diagram 18. If the distance is correct, you have installed the rope properly. If the adjustment knob touches the resistance cylinder mount, you will need to replace the rope and readjust the length.

**Note:** To obtain a new rope call your local Precor dealer at 1-800-4-PRECOR.

Every time you use your climber, make sure that all frame-to-frame and frame-to-base bolts are still tight. If there is any movement, firmly re-tighten all bolts.

## Using the Precor 718e Low Impact Climber

In addition to providing an excellent cardiovascular workout, one of the advantages of the 718e climber is that it is simple to use. With very little time or practice, you can learn how to use it effectively. This section provides information and instructions about the following:

- using the electronic console
- setting the resistance level
- setting a pacer
- pausing your workout
- ending a workout
- exercising on the climber
- sample exercise routines

### Understanding the Electronic Console

Once you have assembled your 718e climber, it is ready to use. There are no complex instructions to follow or mandatory programming steps required to operate the climber—the electronic display is there only for reference. It provides motivating feedback about your workout to help you monitor your progress and meet your fitness goals.

The console's convenient “hands free” function lets you start and end a workout without touching any keys. Simply start using the climber to begin your workout. The displays automatically appear and begin providing information about your workout. To select a specific informational display, such as TIME or TOTAL STEPS, press the MODE key until the desired information appears on the display.

**Diagram 19**  
718e electronic console display

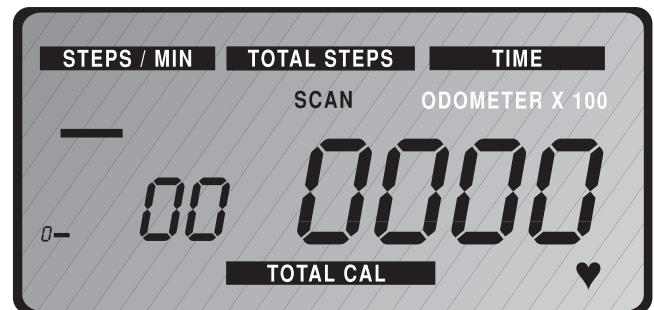

Diagram 19 shows the 718e electronic console display. An explanation of the eight display features and four keys are explained below.

### Displays

**STEPS/MIN**—appears as the smaller numeric display to the left of the main numeric display and indicates your steps per minute, up to 99. The bar graph on the left side of the display can also provide similar information (up to 150 steps—see *Setting a Pacer*), if you have not set a pacer.

**Note:** If the display remains at zero when you move the stair arms, check that the reed switch along the left side of the short column is correctly aligned. Refer to step 10 in the *Assembly Instructions*.

**TOTAL STEPS**—shows the total number of steps during a workout, up to a total of 9,999. You can use this display to measure *total work* accomplished in a workout.



**ODOMETER X 100**—indicates the total number of steps accumulated on the climber over time, up to 999,900. This display appears with the TOTAL STEPS display. Use the odometer to track the amount of “mileage” your climber has on it. Note that you need to multiply the number that appears by 100.

**TIME**—functions like a stopwatch, giving you total exercise time per session, up to 59 minutes and 59 seconds. The TIME display starts or stops automatically when you start or stop a workout. You must press the RESET key to reset the TIME display to 0. (For more information about RESET, see the explanation under *Keys*.) Use the TIME display to keep track of *how long* you have exercised in a given session.

**Note:** If you pause during a workout, the internal clock continues to count and to display the time for another 5 minutes. After 5 minutes, the screen saver feature takes over, saves your workout statistics, and shuts off the displays. If you return to your workout before 5 minutes elapse, the time display reverts to your actual workout time. Refer to *Pausing Your Workout*.

**SCAN**—alternates between the displays STEPS/MIN, TIME, TOTAL STEPS, TOTAL CALories, and PULSE every few seconds. When you press the RESET key or begin a workout by pressing the START/STOP key, the word SCAN appears on the display and indicates that you are in SCAN mode. If you only want one particular feature displayed, press the MODE key until the feature is highlighted. See MODE under *Keys* below.

**PACER**—appears in the bar graph on the left of the electronic display. You can select a pacer up to 150 steps per minute. When you maintain or exceed the pacer’s step rate, the bar stops blinking. The pacer sets a tempo for you to follow which provides motivation and helps you to maintain your exercise intensity.

**TOTAL CALORIES**—displays an estimate of the number of calories being burned during your workout. The estimate is based on a 150 pound (68 kg) person working out at your current steps per minute.

**PULSE**—shows your heart rate if you have installed the Precor receiver *and* put on a Precor/Polar chest strap or attached the pulse detector (Precor’s ear clip option) to the console. When you attach the receiver and put on the chest strap or plug the pulse detector into the console, a ♥ appears on the display at the bottom right corner.

## Keys

**START/STOP**—starts and stops a workout session. However, the electronic console automatically begins displaying information when you move the stair arms. You could use this key to start or stop your workout when you want to keep your warm-up or cool-down sessions separate from your workout statistics.

**MODE**—specifies the information you want displayed; whether its STEPS/MIN, TIME, TOTAL STEPS, TOTAL CALories, PULSE or SCAN mode. Simply press this key repeatedly until information from the desired display appears.

**PACER**—sets a pace tempo. When you press this key the pacer appears in the bar graph on the left side of the display. To set the pace tempo or change the current pacer setting, press the PACER key until the desired step rate is highlighted. Refer to *Setting a Pacer*.

**RESET**—resets the displays on the electronic console to zero. Note that pressing this key does not reset the ODOMETER display. Using the RESET key is another way to keep your warm-up or cool-down sessions separate from your workout statistics.

## Setting the Resistance Level

**CAUTION:** Do not adjust the resistance cylinders after extended continuous use because they can heat up to the point of being uncomfortable to touch.

Before using the 718e climber, you need to adjust the resistance level. Resistance, which is related to your body weight and your step height during the workout, determines your cadence (the number of steps you can take per minute). The relationship between body weight, step height, and cadence determines how hard you work during a session.

Understanding the principles covered in *General Aerobic Training Information* starting on page 23 will help you select the appropriate resistance for your fitness level and personal fitness goals. To achieve your goals, it is important to use a resistance that allows your heart rate to reach your training zone (see Diagram 24 on page 24) and then maintains that rate for the desired length of time—while you maintain a step height between 4 to 8 inches. (For information about your training zone, see *How Hard Should I Exercise?* in *General Aerobic Training Information*.)

Keep these guidelines in mind when adjusting the resistance cylinders:

- Resistance settings on the 718e climber range from 1 to 12.
- “1” provides a faster cadence (step rate) due to less resistance in the stair arms than “12.”
- The resistance cylinders operate more stiffly at the beginning of a workout until they warm up. You may want to re-adjust the resistance settings after working out for about 5 minutes.

**Diagram 20**  
Setting the resistance level

Resistance setting  
Adjustment knob  
Number  
Indicator arrow  
Resistance cylinder

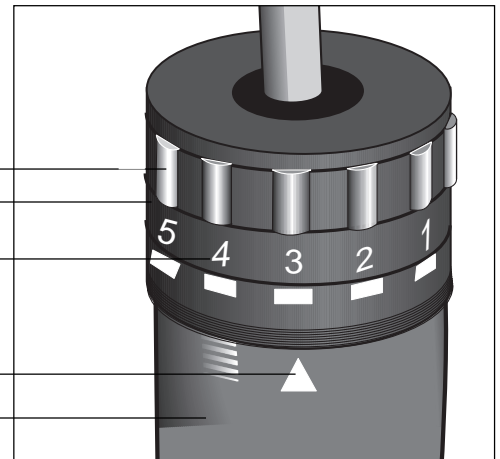

To adjust the resistance level, take the following steps:

**CAUTION:** Make sure that both cylinders are set at the same resistance setting to ensure a smooth, balanced feel during your workout.

1. When beginning your workout, warm up by setting the resistance between 1 and 3. Turn the top of the resistance cylinder so that the number aligns with the arrow. See Diagram 20.
2. Repeat step 1 for the opposite stair arm. Make sure that both resistance cylinders are set on the same number to ensure equal resistance.

**Note:** Allow the resistance cylinders to warm up for at least 5 minutes before raising the resistance setting. After which, you can adjust the settings anytime during your workout. However, after extended, continuous use, the resistance cylinders can heat up to the point of being uncomfortable to touch.

Start exercising at a low setting. Gradually work your way to a comfortable resistance level and into your target heart rate zone (see Diagram 24, page 24).

## Setting a Pacer

Setting a pace tempo provides motivation and helps you to maintain your exercise intensity. To set a pacer, press the PACER key until the bar graph highlights the desired step rate. The bar graph provides incremental markings every 15 steps (15, 30, 45..., to 150). If you bypass the mark that you want to set, continue to press the PACER key. It will cycle around to zero and you can start over. Note that the pacer stops blinking when you maintain or exceed the pacer's step rate.

## Using the Pulse Feature

With the Precor pulse feature, you can use the display to help maintain your heart rate in its training zone. Diagram 24 on page 24 shows your target heart rate or training zone. To receive the best possible cardiovascular fitness level, you want to maintain your heart rate in your training zone while you workout . You can use the pulse feature in one of two ways:

**Diagram 21**  
Precor ear clip and Polar heart rate options

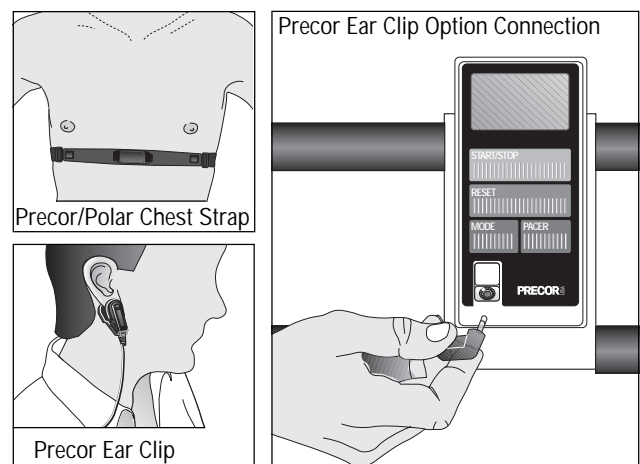

- *Precor Ear Clip Option.* A pulse detector plugs into the electronic console. Your pulse is detected once you attach the ear clip to your ear lobe.
- *Precor Heart Rate Option.* The receiver plugs into the electronic console. When you wear the chest strap the console displays your heart rate.

To use the pulse feature, plug the pulse detector into the electronic console and attach the ear clip to your ear lobe. See Diagram 21. Or, if you have a Precor/Polar chest strap, put it on and plug the receiver into the electronic console.

**Note:** A ♥ appears in the lower right corner of the display when you plug the pulse detector in or attach the receiver and put on the Precor/Polar chest strap.

Follow the workout instructions on the following pages. Use the MODE key to highlight SCAN mode or to select the PULSE display.

**Important:** Your heart rate will not appear if the pulse detector or chest strap cannot transmit a heart beat. This can occur if you remove the ear clip (or chest strap) or the ear clip (or chest strap) becomes dislodged. Occasionally, due to medication, caffeine, or physiology of the heart (such as an irregular heart beat) the receiver in the console cannot correctly detect a heart beat. Verify the accuracy of the heart rate reading by taking your pulse one or twice during your workout. For additional information, review the Owner's Manual that accompanied your Precor Heart Rate Option.

## Pausing Your Workout

Since the climber has an automatic auto-pause feature, you can pause during your workout to answer the telephone or take a short rest. To pause your workout, simply stop stepping on the climber. Five minutes after you stop exercising the electronics unique screen-saver feature turns off the display and saves your position. When you resume your workout and step on to the climber, the displays continue from the point you left off and provide an accurate readout of your total workout time.

**Note:** When you pause, the internal clock causes the TIME display to continue counting. If you return to your workout before 5 minutes elapse, the TIME display reverts back to your actual workout time.

## Ending a Workout

To end your workout, simply stop stepping. You can also press the START/STOP key. In either case, the displays on the console freeze, allowing you to review your workout statistics.

You can then do one of two things: either press RESET to return the displays to zero or let them stand, which lets you track total exercise time and steps over several exercise sessions. The electronics count TIME, TOTAL STEPS, and TOTAL CALories cumulatively, so if you do not press RESET at the end of your workout, the electronic console will continue counting from the point you left off.

With the console's unique screen-saver feature, you do not have to worry about turning OFF the console when you finish your workout. Five minutes after you stop exercising the screen-saver turns OFF the display.

## How to Use the 718e Climber

This section explains how to work out on the climber safely and effectively. When using the climber, follow these general guidelines:

- At the beginning of a workout, warm-up by taking several minutes to bring your heart rate into your training zone (see Diagram 24 on page 24).
- After your workout, walk slowly for several minutes to cool down your body and lower your pulse rate.
- Protect your knees by keeping them directly over your toes. Avoid taking steps that are too big or bending your knees beyond 90 degrees.
- Keep your feet on the black footpads—moving your feet too far forward might cause you to bump the cylinders with your knees.
- Keep your shoulders and back relaxed. Hold your head up—looking at your feet or the floor strains your neck and back muscles. Avoid bouncing or swinging your hips from side to side.
- Set the resistance at a low level initially until your muscles warm up and your heart rate reaches its target zone. You can then increase the level to the desired setting for working out.
- Gently stretch your lower body and back after a workout to help prevent stiffness or soreness.

**CAUTION:** Before beginning any fitness program, you should have a complete physical examination by your physician.

## Working Out on the 718e Climber

To use the 718e climber, take the following steps:

1. Press RESET on the electronic console and hold for 3 seconds. Release the key at the "beep" sound. Press MODE until the TIME function is highlighted and the TIME display appears.

**Diagram 22**  
Working out on the 718e



2. After you have set the resistance level at a low setting and finished any desired pre-workout stretching, step onto the climber. Make sure that your weight is balanced and your hands and feet are positioned securely. Refer to *How to Use the 718e Climber*.
3. Start your workout by taking steps 4 to 8 inches in height, at a cadence that will allow your heart rate to reach your training zone within 5 minutes. See Diagram 22. To get your heart rate into your training zone, you might have to adjust the resistance setting.

**Note:** To increase your heart rate, increase the step speed by adjusting the resistance cylinder to a lower setting. To slow your heart rate, slow the step speed by moving to a higher setting.

4. After your warm-up period, maintain your heart rate in your training zone during your aerobic session. As you work out, vary your body position to reduce localized muscle fatigue and to exercise all your lower body muscles. See *Sample Exercise Routines*.
5. When you are finished exercising, cool down for 3 to 5 minutes by gradually reducing your step rate and height. If earlier you decreased resistance for your aerobic session, move the resistance level to a higher setting to help your body cool down. A proper cool-down helps to transport excess lactic acid out of the working muscles, allowing them to recover faster.
6. To end your workout, simply stop stepping. You can also press the START/STOP key. In either case, the displays on the console freeze, allowing you to review your workout statistics. Press RESET to return the displays to zero or let them stand, which lets you track exercise time and steps over several sessions. Five minutes after you stop exercising, the display automatically turns OFF.

For best results, vary your workouts by changing duration, intensity, footstep, body position and type of work (such as interval training). Keep track of your workouts by writing them down so you can monitor your progress toward your fitness goals and use the information to plan interesting and challenging workouts.

**CAUTION:** Before beginning any fitness program, you should have a complete physical examination by your physician.

**CAUTION:** Make sure that both cylinders are set at the same resistance to ensure a smooth, balanced feel during your workout.

**CAUTION:** Throughout your workout, periodically check your heart rate. Never allow your heart rate to exceed 80% of your training zone. Refer to Diagram 24 on page 24 to determine the training zone that is appropriate for your age group.

### Sample Exercise Routines

For a good upper body workout, set the resistance cylinders at a moderate level—between the markings 4 and 6 and take the following steps:

1. Stand erect with your feet placed firmly on the stair arm footpads.
2. To maintain your balance after stepping onto the stair arms, place your hands in a comfortable position on top of the handrails, palms facing down. You should have a slight bend at your elbows. Do not straighten your arms out completely and do not place your weight on the handrails, use the handrails for balance only.
3. As you transfer your weight and press down with one leg, the opposite leg should rise to about a 90 degree angle. Do not raise your leg above a 90 degree angle as you can cause injury to yourself.
4. Become familiar with the movement of the stair arms. Transfer your weight between stair arms in one fluid motion. Do not bounce, bob, or rock up and down or back and forth. Keep your back straight and erect while you work out.

When you first start out, try a one-minute rest and one-minute work interval. During the rest interval, you should let your body relax, continuing to transfer your weight from one stair arm to the other with your hands relaxed, yet maintaining your balance holding onto the handrails. During the work interval, concentrate on your movement, keeping your knees bent, pushing down and lifting up, in one continuous motion.

**Calf muscle workout**—during your downward stroke, as the pedal tails away, let your heel come off the foot pedal. This helps work your calf muscle group.

**Gluteal and Hamstring workout**—Bend your arms at the elbow and place them along the upper length of the handrail. Bend your body at the hips while you rest your arms on the handrails. Then, keep your back straight while you bring your knees up toward your chest to begin working your gluteals and hamstrings. Remember, do not bend your knees more than 90 degrees, as you can cause injury to yourself.

**Quadricep workout**—Hold onto the handrails while you sit back, knees bent, placing your weight directly over the footpads. You should be able to feel light pressure on your quadriceps. *Do not position your weight so far back that the front crossbar on the climber comes off the floor.* Keep your back straight, in an upright position, as you take shorter, faster steps. Keep your knees bent throughout your workout to isolate and work out your quadricep muscles.

## General Aerobic Training Information

A workout on the Precor 718e climber provides excellent and efficient cardiovascular conditioning, while strengthening and toning the thighs, calves, and hips. The darkened areas in Diagram 23 indicate the muscles improved.

**Diagram 23**  
Muscles exercised during a stair climber workout.

1. Trapezius
2. Deltoid
3. Pectorals
4. Rhomboids
5. Triceps
6. Biceps
7. Latissimus Dorsi
8. Forearm Flexors/Extensors
9. Abdominals
10. Erector Spinae
11. Gluteals
12. Hip Flexors
13. Quadriceps
14. Hamstrings
15. Gastrocnemius/Soleus
16. Peroneus Longus/Brevis

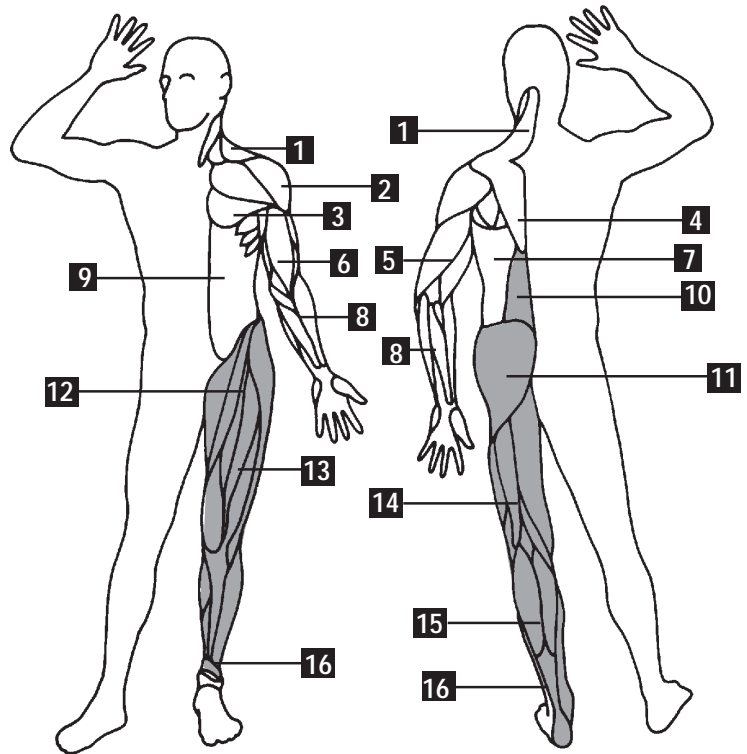

To get the most out of each workout, a general understanding of the principles behind aerobic training is invaluable. The best source of fitness information is your specialty fitness dealer. In addition to providing information on which exercise equipment is the best for your individual needs, your specialty fitness dealer can provide useful advice on training, technique, and exercise physiology. Your dealer can also recommend good books on these subjects.

To help you get started in planning and carrying out your fitness program, this section provides some basic information on aerobic exercise—such as how hard you should work out, how long each session should be, and how often you need to exercise to benefit from a regular program.

**Diagram 24**  
Heart rate training zones

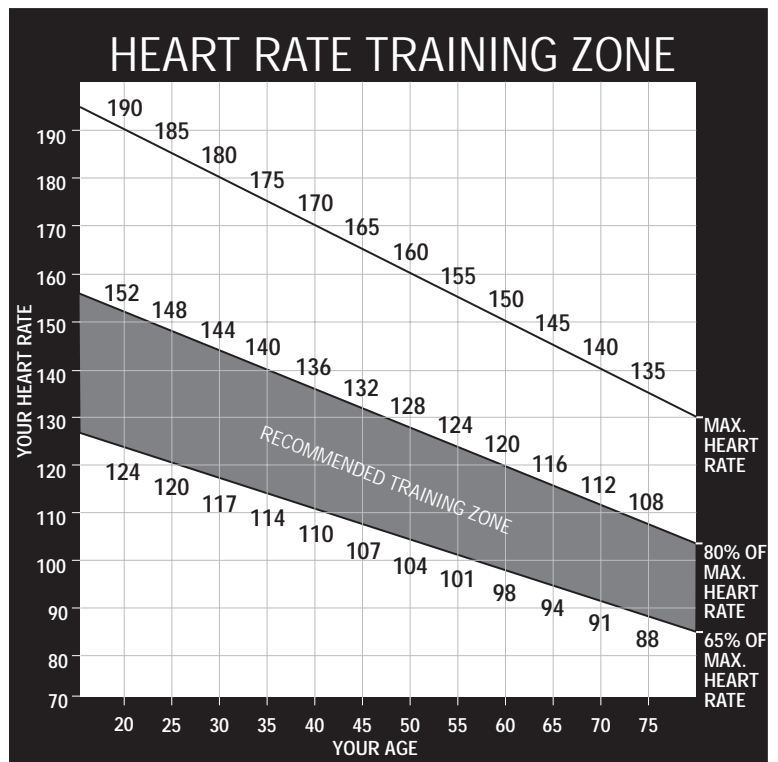

#### How Hard Should I Exercise?

Studies have shown that to achieve the benefits of aerobic exercise, it is necessary to work out hard enough to raise your heart rate to a certain minimum level, called the "training zone." Your training zone depends on your age and level of fitness.

Diagram 24 shows your recommended heart rate training zone, which is calculated using your age and your maximum attainable heart rate. The chart is based on a resting heart rate of about 72 for males and 80 for females. Your optimum training zone is between 65% and 80% of your maximum heart rate. For efficient aerobic exercise, work only hard enough to keep your heart rate in this zone. You will obtain the greatest fat-burning benefits when you exercise within the optimum training zone.

Pushing yourself beyond the recommended range, (that is, exercising so hard that your heart rate rises above 80% of maximum) can overstress your muscles. To increase cardiovascular improvement, exercise *longer*, not harder.

Keep in mind that this zone is an approximation, to be used as a guideline—individual heart rates vary according to several physiological factors. To determine your training zone, find your age on the diagram, and then find the area where the training zone and your age intersect. For example, if you are 35 years old, your training zone is between 114 and 140 beats per minute. Remember this zone—this is the heart rate you should try to maintain as you work out.

To determine your heart rate, take your pulse at a place that you can reach easily and comfortably while you exercise. Typical places for measuring heart rate are directly over the heart on the left side of the chest, on either side of the neck, over the temple, or on the thumb side of either wrist. Wherever you measure your pulse, make sure that you use your index and middle fingers—*not your thumb*. Your thumb has a strong pulse, which can affect your heart rate reading.



Once you locate your pulse, look at a watch or a clock with a second hand and count the beats for six seconds. Multiply that number by 10 to determine the total number of beats per minute. For example, if you count 14 beats over six seconds, the total number of beats per minute is 140. Compare the total number of beats with your training zone as identified in Diagram 24. If necessary, increase or decrease your activity level to bring your heart rate into your training zone. You can increase your activity level by increasing your resistance level and stepping at a higher cadence. Similarly, lowering the resistance and decreasing your steps per minute will lower your heart rate. *Remember—your heart rate is the definitive measure of how hard you are working.*

Regardless of your fitness level, avoid doing too much too soon. Setting the resistance level too high, stepping too deeply (taking large steps), or stepping too quickly for too long are common errors. Give yourself time to become familiar with your climber and improve your fitness level. Then you can gradually increase your resistance level and stepping cadence to make your workouts more challenging.

### **How Long Should I Exercise?**

The length of each exercise session depends on your fitness level. Exercise physiologists have determined that, to attain cardiovascular benefits from exercise, you should maintain your heart rate in the training zone for at least 15 minutes. This does not include warm-up and cool-down time. You should always allow several minutes to bring your heart rate into the training zone, by starting out slowly and gradually increasing the work level. Similarly, use several minutes of light exercise after the workout to bring your heart rate down to near resting level.

The higher your fitness level, the longer you should maintain your heart rate in the training zone (between 20 and 30 minutes). Beginners should always start slowly, and gradually increase their sessions to 20 minutes or more.

### **How Often Should I Exercise?**

Research indicates that aerobic sessions of 20 minutes or more should be done at least 3 to 5 times a week to obtain significant cardiovascular benefits. Most experts agree that sensible eating habits and regular aerobic exercise are the keys to weight control and fitness. A recent study, which tracked several subjects over a period of years, conclusively shows that exercise, not dieting, is the key factor to successful long-term weight loss.

## Maintenance and Troubleshooting

The 718e climber requires very little maintenance. The only maintenance you need to do periodically is to clean the climber. You will also need to change the batteries when they wear down. Instructions for these procedures are provided in this section.

If you encounter problems with the climber, refer to *Troubleshooting Tips* in this section for help.

### Cleaning the Climber

**CAUTION:** *Abrasive cleaners or polishes will damage the surface finish.*

Clean the 718e climber periodically with mild solution of soap and water or a general household cleaner. Wipe the surface of the electronic console with a moist sponge or cloth. Dry with a clean towel. Never pour liquids on the 718e electronic console.

### Changing the Batteries

The electronic console comes with two "AA" alkaline batteries installed. When your console no longer shows a digital readout or the count becomes erratic, you need to change the batteries.

**Note:** Occasionally, the batteries can become dislodged, so you need to reposition the batteries in the drawer, but not necessarily replace them with new batteries.

1. Find the drawer on the side of the electronic console and press in lightly to open it.
2. Use your fingers to slide the drawer out and expose the battery case. Remove the old batteries and replace them with two new "AA" alkaline batteries. The displays light up and the console beeps.

**Note:** Align the batteries to the proper polarity (+ and - indicators are inside the battery case).

3. Close the battery drawer by pushing it gently into the electronic console.
4. Press START/STOP to activate the timer (TIME display).

**Note:** Press RESET to "reset" the displays to zero.

## Troubleshooting Tips

Check the chart below to see if your problem is listed. If the following information does not solve a particular problem, call your authorized Precor dealer. See *Obtaining Service* in this section for information

<b>Problem</b>	<b>Solution</b>
<b>Electronics, no display</b>	<ul style="list-style-type: none"><li>• Replace batteries. See instructions on the previous page.</li><li>• Clean battery connections.</li></ul>
<b>Electronics, no stroke count</b>	<ul style="list-style-type: none"><li>• Reed switch to magnet spacing is incorrect. Electronic unit shuts down after 5 minutes—see step 10 in the <i>Assembly Instructions</i>.</li><li>• Magnet placement incorrect.</li><li>• Pinched or severed cable.</li></ul>
<b>Frame loose</b>	<ul style="list-style-type: none"><li>• Recheck and tighten frame and base bolts.</li></ul>
<b>Squeaks</b>	<ul style="list-style-type: none"><li>• Lubricate the rope pulley mechanism.</li><li>• Lubricate resistance cylinder connectors.</li><li>• Check bolts for tightness.</li></ul>

## Obtaining Service

Do not attempt to service the 718e climber yourself except for changing the batteries or performing other maintenance tasks as described in this manual.

For further information about product operation or service, contact an authorized Precor dealer (or a Precor Factory Authorized Service Company). To locate the Precor dealer nearest you, call 1-800-4-PRECOR.

To help the customer service representative expedite your call, have your serial number readily available. Use the model and serial numbers whenever you call your Precor dealer or the customer service representative. The serial number on the 718e climber is located on the underside of the base.

Model number: 718e Serial number: \_\_\_\_\_



Precor Incorporated  
P.O. Box 3004  
Bothell, WA USA 98041-3004

Precor is a registered trademark of Precor Incorporated.  
© 1988 Precor Incorporated, Rd. 1989.

P/N 31295-112  
6/95

Specifications subject to change without notice.  
1-800-4-PRECOR

**NOTICE:**

Precor is widely recognized for its innovative, award winning designs of exercise equipment. Precor aggressively seeks U.S. and foreign patents for both the mechanical construction and the visual aspects of its product design. Any party contemplating the use of Precor's product designs is hereby forewarned that Precor considers the unauthorized appropriation of its proprietary rights to be a very serious matter. Precor will vigorously pursue all unauthorized appropriation including through legal actions.