

### TABLE OF CONTENTS

<b>1. INTRODUCTION</b> .....	<b>2</b>	<b>4. TESTING PROCEDURES</b> .....	<b>8</b>
<b>2. SPECIFICATIONS</b> .....	<b>2</b>	4.1 Preparations .....	8
2.1 General Data .....	2	4.2 Diagnostic Test.....	8
2.2 RF Section.....	2	4.3 Keyfob Transmitter Test .....	8
2.3 Electrical Data .....	2	4.4 Appliance ON/OFF Test .....	9
2.4 Communication .....	3	4.5 Emergency Transmitter Test .....	9
2.5 Physical Properties .....	3	<b>5. MAINTENANCE</b> .....	<b>9</b>
<b>3. INSTALLATION</b> .....	<b>3</b>	5.1 Dismounting the Control panel .....	9
3.1 Unpacking the Equipment .....	3	5.2 Replacing the Backup Battery .....	9
3.2 Supplying Power to the Unit.....	3	5.3 Fuse Replacement .....	10
3.3 Programming.....	4	<b>APPENDIX A. DETECTOR DEPLOYMENT AND</b>	
3.4 Mounting the Bracket .....	4	<b>TRANSMITTER ASSIGNMENTS</b> .....	<b>11</b>
3.5 Wiring .....	5	A.1 Detector Deployment Plan .....	11
3.6 Attaching the Control Panel to the Bracket .....	6	A.2 Keyfob Transmitter List .....	11
3.7 Connecting the AC Transformer.....	6	A.3 Emergency Transmitter List .....	12
3.8 PowerMax-Compatible Detectors.....	7	A.4 Non-Alarm Transmitter List .....	12
3.9 PowerMax-Compatible Transmitters .....	7	<b>APPENDIX B. X-10 UNIT ASSIGNMENTS</b> .....	<b>12</b>
3.10 Mounting the RS232 Module.....	8	<b>FCC STATEMENTS</b> .....	<b>13</b>
3.11 Installing an Optional X-10 Siren.....	8	<b>DECLARATION OF CONFORMITY</b> .....	<b>14</b>

### MESSAGE TO THE INSTALLER

The PowerMax control panel is supplied with 3 instruction manuals:

- **Installation Instructions** (this manual - for your exclusive use)
- **Programming Guide** (for your exclusive use)
- **User's Guide** (for your use during installation only. Must be handed over to the master user after testing the system).

Appendices A and B to the installation instructions will help you prepare an installation plan. Please take time to fill out the forms - your job will become much easier and confusion will be prevented. Filling out the forms will also help you create a list of detectors and transmitters that must be obtained for the particular application. Compatible detectors and transmitters are listed and described briefly in Paragraphs 3.8 and 3.9 of this manual.

Remember - it is advisable to power up the control panel temporarily after unpacking and program it on the work bench, in accordance with the installation plan. Paragraph 3.3 of this manual refers you to the programming guide.

The programming flow charts in the programming guide show all options available for each parameter. Factory defaults are marked with a dark box to their right, and other options (that can be selected instead) are marked by clear boxes. This method allows you to put a checkmark in the appropriate clear box whenever you deviate from the factory defaults.

To increase the backup time provided by the Ni-Cd battery (which is 4 -6 hours), we recommend the use of 6 size AA Ni-Mh cells with a capacity of 1600 mAh (produced by GP). Under AC failure conditions, these batteries provide up to 20-hour backup with no alarms, and up to 16 hours if an alarm occurs (**not to be used in UL-listed systems**).

Although setting the correct time and date is one of the user tasks, we recommend that you set the time and date in the course of programming. Access to the "User Settings" is possible through item 9 on the installer's menu (see User's manual for exact procedure).

When you are through programming, proceed to install the system as detailed in the Installation Instructions, from paragraph 3.4 onward.

**WARNING! The PowerMax control unit has not been investigated by UL for household fire.**

**WARNING! All model PowerMax outputs are not power limited and shall not be used in UL-listed Systems.**

**WARNING! Zone type "emergency" can not be used for medical applications in UL-listed systems.**

The installer should verify line seizure. Be aware of other phone line services such as DSL.

# 1. INTRODUCTION

The PowerMax is a user and installer-friendly, 30-zone fully-supervised wireless control panel. The system is designed to function in a way that appeals to the user but also offers features that make installers' life easier than ever before:

## EASY TO INSTALL

- Plug-in terminal blocks can be wired while detached from the unit.
- Quick attach-detach TELCO sockets for telephone line, telephone set and X-10 controller.
- Special wall-mounted bracket permits installation without having to open the unit's cabinet.
- Optional plug-in RS-232 module for local computer.

## EASY TO MAINTAIN

- Status, alarm memory and trouble data displayed upon request.

- Diagnostic test provides visual and audible indication of the signal level of each detector.
- Remote control and status verification from distant telephones.
- Event log stores and displays information on 100 past events.
- Upload / download from distant computer via telephone line and modem.
- Backup battery uses standard, easily obtained cells.

## QUICK PROGRAMMING

- Multiple-choice selection of options for each parameter.
- Unequivocal visual prompts and audible signals.
- The installer can gain access to the user menu.

A fully equipped alarm system based on the PowerMax consists of the units shown in Figure 2 of the user's guide.

# 2. SPECIFICATIONS

## 2.1 General Data

**Number of Zones:** 29 wireless, 1 hardwired (zone No. 30).

**Hardwired Zone Requirements:** 2.2 k $\Omega$  E.O.L. resistance (max. resistance of wires 220  $\Omega$ ).

**Zone Types:** Interior, perimeter, delay 1, delay 2, 24 hours - audible, 24 hours - silent, fire, non-alarm and emergency.

**User Codes:** 8 codes, 4 digits each

### Control Facilities:

- Integral keypad,
- PowerCode / Code-Secure™ hand-held transmitters,
- Remote telephone,
- Local or remote computer.

**Display:** Single line, back lighted 16-character LCD and 4 LED indicators

**Arming Modes:** AWAY, HOME, AWAY-INSTANT HOME-INSTANT, LATCHKEY, FORCED.

**Alarm Types:** Silent alarm, siren alarm or sounder (internal) alarm, in accordance with zone attributes.

**Siren Signals:** Continuous (intrusion / 24 hours / panic); triple pulse - pause - triple pulse... (fire).

**Siren Timeout:** Programmable (4 minutes by default)

**Internal Sounder Output:** at least 85 dBA at 10 ft (3 m)

**Supervision:** Programmable time frame for inactivity alert

### Special Functions:

- Speech and sound control
- Powerline Carrier Device Control (up to seven X-10 brand units) by various factors, as programmed
- Chime zones
- Diagnostic test and event log
- Remote control by telephone
- Computer control and data download/upload
- Calling for help by using an emergency transmitter
- Tracing inactivity of elderly, physically handicapped and infirm people.
- Message center (recording and playback)
- Two-way voice communication

**Data Retrieval:** Status, alarm memory, trouble, event log.

**Real Time Clock:** The control panel keeps and displays time and date.

### Compliance with U.S. Standards:

**UL1023:** household burglar alarm system unit - Grade A Meets FCC Part 15 and Part 68 requirements.

### Compliance with European Standards:

**EMC Emission:** EN 50081-1 1992

**RFI:** EN55022 1998

**EMC Immunity:** EN 50082-1 1997

**EMC Immunity to Conducted RF:** EN6100-4-6 1996

**Telephony:** TBR21 1998

**Safety:** EN60950+ Am1(93), Am2(93), Am3(95), Am4(97)

The PowerMax is compatible with the RTTE requirements - Directive 1999/5/EC of the European Parliament and of the Council of 9 March 1999.

## 2.2 RF Section

**Operating Frequencies:** 315 MHz or other UHF channels per local requirement in the country of use.

**Receiver Type:** Super-heterodyne, fixed frequency

**Receiver Range:** 600 ft (180 m) in open space

**Coding:** PowerCode and/or CodeSecure™

## 2.3 Electrical Data

**Power Supply:** Plug-in transformer.

120 VAC, 60 Hz / 9 VAC, 700 mA (in the U.S.A.)

230 VAC, 50 Hz / 9 VAC, 700 mA or 230 VAC, 50 Hz / 9 VAC, 1A (**not for UL-listed systems**).

**UL installation:** Use transformer type OH-41073AT

**In Europe and elsewhere:** Use only Safety National Approved AC adapter, mains-to-9 VAC, 0.7A or 1A.

**Current Drain:** Approx. 95 mA standby, 500 mA at full load and in alarm.

**PGM (auxiliary) Output Current:** 100 mA max.

**Sounder Output Current with 700 mA Transformer**

**Internal sounder:** 50 mA max.

**External sounder:** 150 mA max.

**Attention!** The external sounder can be allowed to draw up to 300 mA if the internal siren and PGM output are not used.

**CAUTION:** The sounder and PGM outputs can not be used in UL installations!

## Sounder Output Current with 1A transformer

Internal sounder: 50 mA max.

External sounder: 350 mA max.

**Attention!** The 350 mA rating is valid only for units with a sticker that says "Option: 9VAC / 1A plug-in transformer"

**Fuse Ratings:** 1A for battery protection (in U.S. variants only). Other variants use 650 mA PTC circuit protector.

0.5 A for siren / sounder circuit protection.

**Backup Battery** (provides power for at least 4 hours)

**Option 1** - 9V, six alkaline AA cells, 1.8 Ah

**Option 2** - 7.2 V, six Nickel Cadmium rechargeable AA cells, 650 mAh

**UL installations:** Use rechargeable cells - Golden Power KR650AA1

**In Europe:** For rechargeable cells, use BYD Battery Company Ltd. D-AA700A (1,2 V / 700 mAh).

**Battery Test:** Once every 24 hours, and once per hour during AC power loss.

## 2.4 Communication

**Built-in Modem:** 300 baud, Bell 203 protocol

**Data Transfer to Local Computer:** Via RS232 serial port

**Report Destinations:** 2 central stations, 4 private telephones, 1 pager

**Reporting Format Options:** SIA, Pulse 4/2 1900/1400 Hz, Pulse 4/2 1800/2300 Hz, Contact ID

**Pulse Rate:** 10, 20, 33 and 40 pps - programmable

**Message to Private Phones:** Tone or voice

**Message to Pager:** PIN No. → Alarm Type → Zone No.

## 2.5 Physical Properties

**Operating Temp. Range:** 32°F to 120°F (0°C to 49°C)

**Storage Temp. Range:** -4°F to 140°F (-20°C to 60°C)

**Humidity:** 85% relative humidity, @ 30°C (86°F)

**Size:** 9-13/16 x 7-1/2 x 1-3/4 in. (250 x 190 x 44 mm).

**Weight:** 2 pounds (905 g) less batteries

**Color:** Ivory and charcoal gray

## 3. INSTALLATION

### 3.1 Unpacking the Equipment

Open the cardboard packing box and check whether all items have been included. If you find out that an item is missing, contact your vendor or dealer immediately.

### 3.2 Supplying Power to the Unit

Enrolling the transmitting devices' ID codes in the PowerMax memory will be easier if carried out before actual installation, with all detectors and the control panel on a work bench. It is therefore necessary to power up the PowerMax temporarily from the external power transformer or from its backup battery.

Connect a twisted pair between the transformer's 9 VAC screw terminals and the **9 VAC POWER** terminals (located in the rectangular opening at the back of the PowerMax cabinet - see Figure 10).

**Note:** If the transformer does not have screw terminals, connect the transformer's integral twisted pair across the **9 VAC POWER** terminals of the PowerMax.

Disregard any "trouble" indications that may appear (due to lack of battery or lack of telephone line connection).

Alternatively, you may power up from the backup battery:

**A.** Insert a screwdriver into the slot shown in Figure 1.

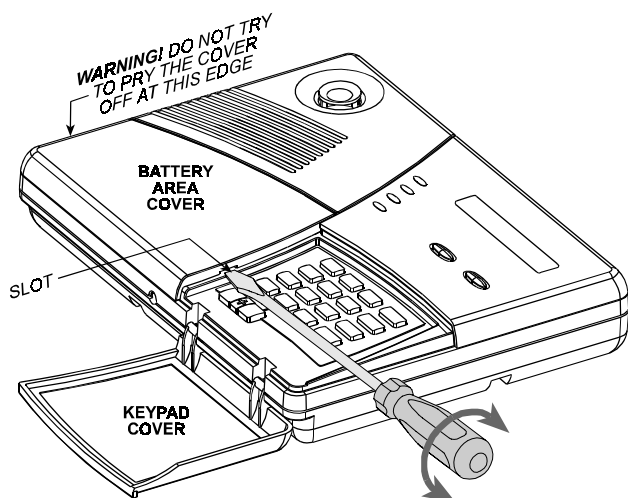

Figure 1. Prying the Cover Loose

**B.** Turn the handle slightly to force the right edge of the cover up. This should dislodge the two catches and release the right edge of the cover.

**WARNING!** Do not attempt to dislodge the left side of the cover first! This will inevitably break the left-side angled legs.

**C.** Swing the cover up as shown in Figure 2, then pull free the angled legs at the left and put the cover away. The inner lid will now be in full view (see Figure 3).

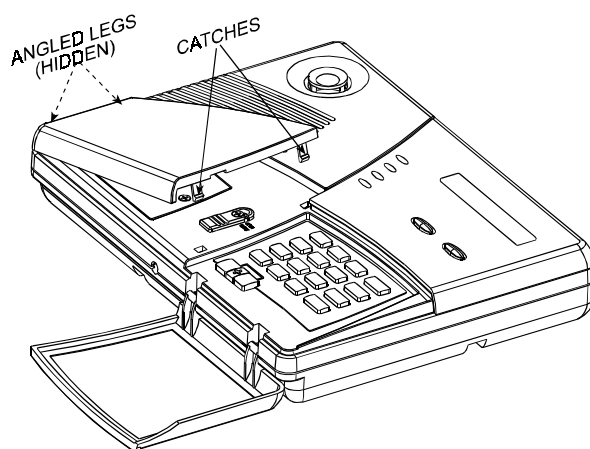

Figure 2. Removing the Battery Area Cover

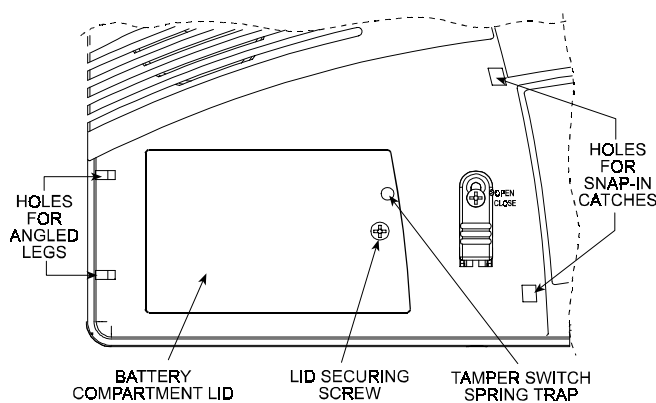

Figure 3. Battery Area after Cover Removal

- D. Remove the screw that secures the lid (see Figure 3), swing the lid up and pull it away. You now have access to the battery holder (see Figure 4).
- E. Pull out the battery holder and check that the battery type selection jumper is positioned in accordance with the type of batteries being installed (see Figure 4). For alkaline (dry) cells, the jumper should be mounted on the two lower pins. For Nickel Cadmium (rechargeable) cells - on the two upper pins.

**CAUTION!** Verify that the jumper is at the correct position for the actual battery cells being installed.

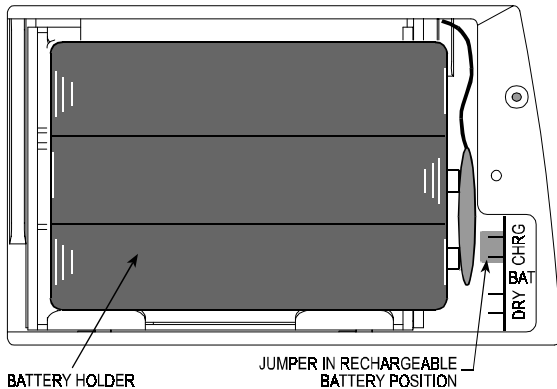

Figure 4. Battery Type Selection Jumper

- F. Insert all 6 battery cells - 3 at the top and 3 at the bottom. Make sure that the flat (-) end of each cell is pressed against a circular spring and the capped (+) end of each cell is pressed against a flat contact.

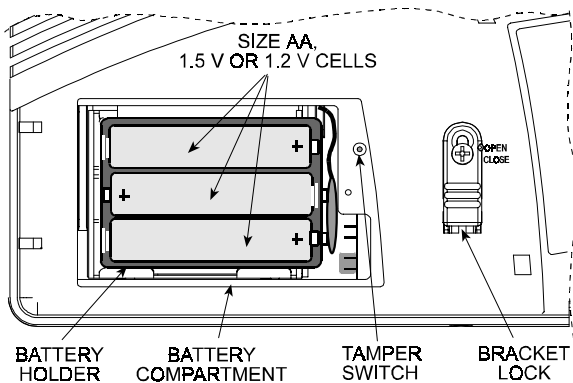

Figure 5. Battery Holder in Place with Batteries Installed

- G. Put the battery holder back in, re-mount the battery compartment lid and re-attach it using the screw. **Disregard any trouble indications that may appear** (due to lack of AC or lack of telephone line connection).
- H. Put back the battery area cover - insert the angled legs at the left edge into their holes and then press the right edge of the cover against the cabinet surface until the catches click into place.

### 3.3 Programming

It pays off to plan ahead - use the tables in appendices A and B at the end of this guide to register the intended location of each detector, the holder and assignment of each transmitter and the control plan for the X-10 units.

Gather up all transmitters and detectors used in the system and mark each one in accordance with your deployment plan.

**Program the system now as instructed in the PowerMax programming Guide (Publication DE5450P).**

## 3.4 Mounting the Bracket

### A. Detaching the Bracket from the Cabinet

A notable advantage of the PowerMax is that the unit can be mounted without having to open its cabinet. All connectors and terminals are accessible through a rectangular opening at the rear, and wiring channels are provided across the rear of the cabinet. Quick mounting of the PowerMax is possible by virtue of a special bracket and a unique mechanical coupling / locking mechanism.

The control panel comes with the bracket in place at the rear. The bracket lock at the front (see Figure 5) is left open. Since a catch at the lower end of the bracket is trapped within the cabinet, a special plastic key (supplied in the kit) must be used to release it - see Figures 6 & 7.

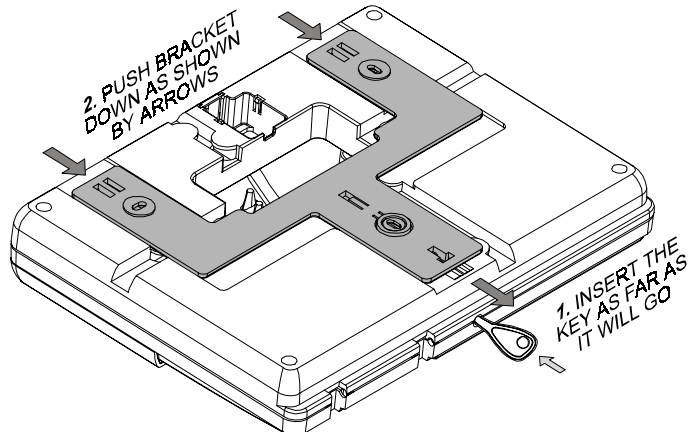

Figure 6. Releasing the Bottom Catch from the Trap

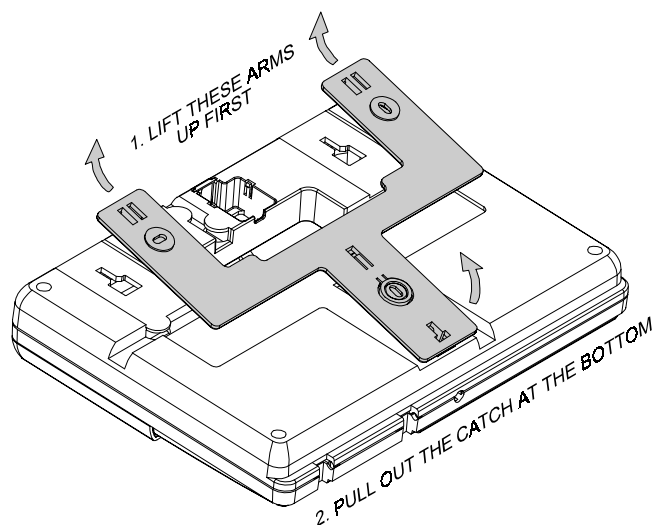

Figure 7. Detaching the Bracket

### B. Getting Acquainted with the Bracket

Having detached the bracket successfully, put it on a desk and observe its design - see Figure 8 for identification of its various parts.

The upper and lower mounting holes are intended for regular attachment to the wall with screws and anchors.

A special "ring and cam" piece is connected to the bottom leg of the bracket by 3 breakable plastic joints. A large plastic washer supplied with the bracket must be inserted into the ring to allow fastening the ring to the wall. With the washer in place, a fourth screw can be used to secure the ring and cam piece to the wall.

Once the control panel is mounted in place, the cam enters a slot in the control panel's rear part and maintains the built in tamper switch pressed. Separating the control

panel from the bracket will start a tamper alarm. Forcibly removing the entire assembly off the wall will also start a tamper alarm, because the joints of the **ring and cam** piece to the bracket leg will break off, leaving the ring and cam attached to the wall.

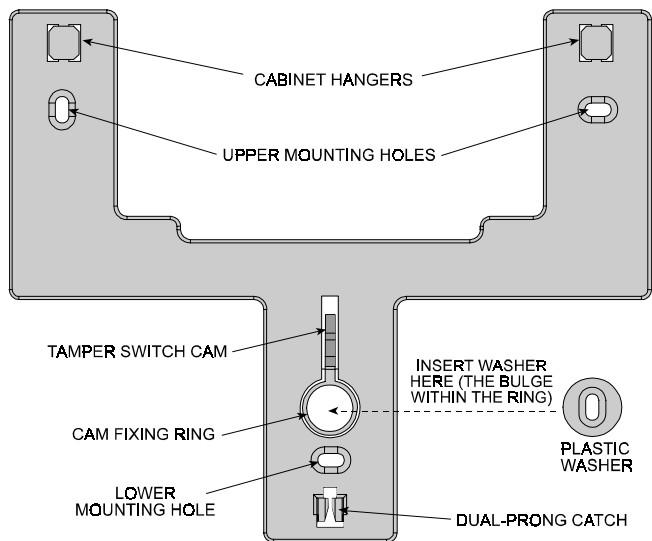

Figure 8. Bracket - Front View

### C. Attaching the Bracket to the Wall

Choose a concealed place, yet easily accessible to prospective users of the alarm system. Make sure that an uninterrupted AC power outlet and a telephone line socket are available near the installation spot.

Use the bracket as a template to mark the drilling points.

**NOTE: ZONE NO. 30 TERMINALS ARE BRIDGED WITH A 2.2 kΩ RESISTOR AT THE FACTORY. THIS RESISTOR SHOULD REMAIN THERE IF NO HARDWIRED SENSORS ARE USED.**

Drill the holes and attach the bracket to the wall with 4 screws. Be sure to insert the special plastic washer into the ring, as shown in Figure 8.

### 3.5 Wiring

All terminals and connectors are accessible within the opening at the back of the PowerMax (see Figure 9). All screw terminal blocks can be pulled out, wired appropriately and plugged back in.



**WARNING!** When plugging terminals back into place, be sure to align them carefully with the pins on the PCB. Mis-aligned or reverse insertion of terminals may damage internal PowerMax circuits!

The telephone-type connectors are also easy to deal with, because of their quick attach/detach capability.

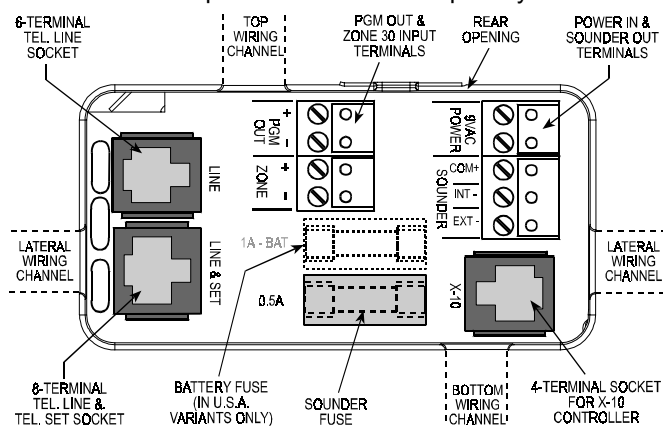

Figure 9. Sunken Wiring Area Layout

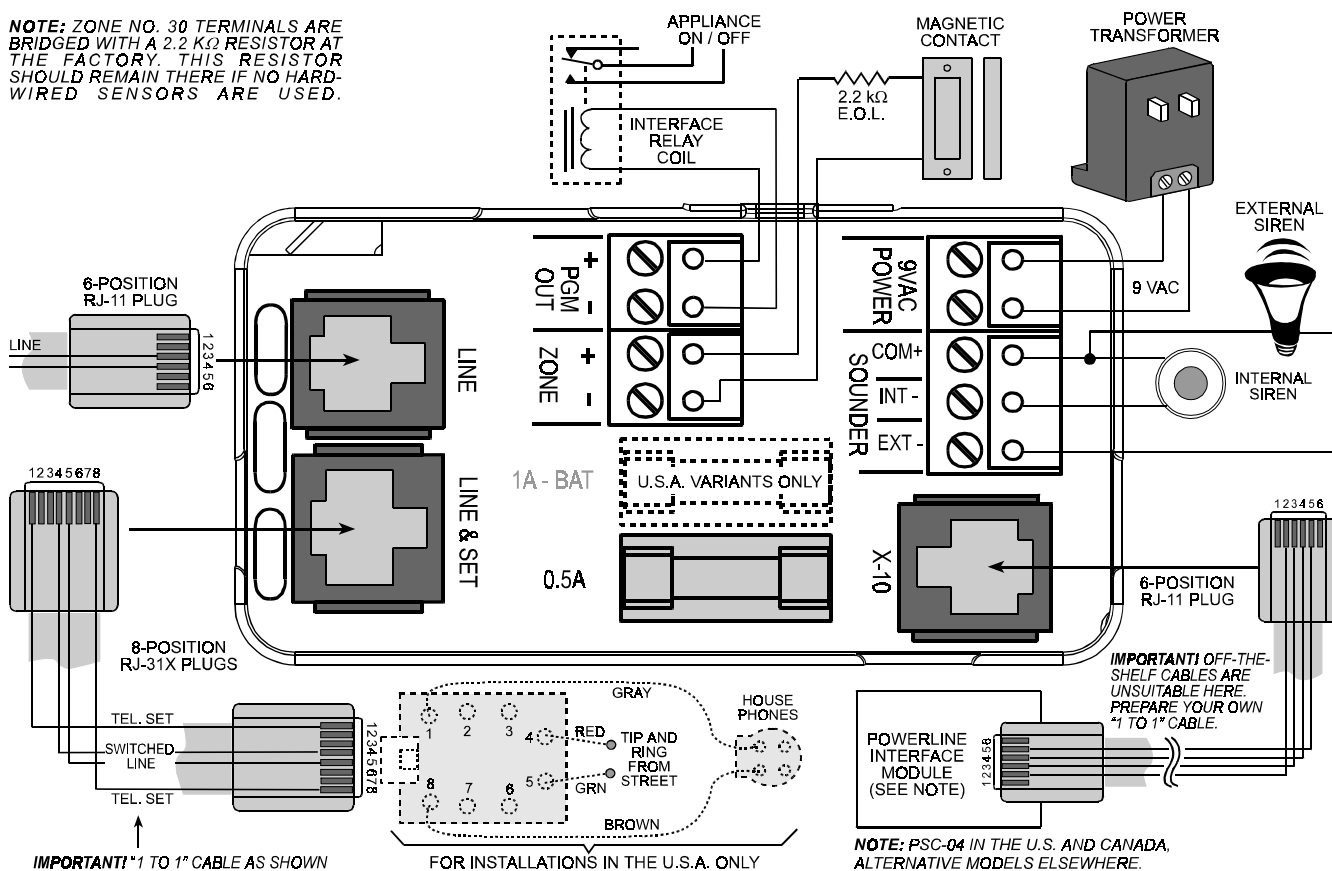

Figure 10. Wiring Diagram

**CAUTION:** The sounder and PGM outputs can not be used in UL-listed installations

You will need the following telephone-type cords:

- **For telephone line hookup only (installations where line seizure is not required):** 6-lead RJ-11 cord(s).
- **For telephone line-and-set hookup (typical installation requiring line seizure):** 8-lead RJ-31X cord(s).

**Note:** RJ-11 and RJ-31X cords are available as either single ended with flying leads at the other end, or double-ended. Use a double-ended cord if the telephone line jack is located near the panel. If the telephone line jack is far away, use two single ended cords and splice them together with 4-conductor cable.

- **For X-10 connection:** 6-lead RJ-11 double-ended cord. Only 4 leads are used - make sure the cord is "1 to 1".

Refer to Figure 10 and proceed as follows:

- A. Use the cords to complete the following connections:
- The **LINE** socket to the telephone line (or the **LINE & SET** socket to the telephone line and the local telephone set).
  - The **X-10** socket to the powerline interface module.
- B. Extract the screw terminal blocks one by one and make the necessary connections. When done, plug each terminal block onto its PCB mounted pins.

**IMPORTANT! The terminals for internal and external sounders are DC outputs intended for 9V sounders. Connecting a loudspeaker to any of these outputs will cause a short circuit and will damage the unit.**

- C. Route the wires and cords via the rear wiring channels. With all wires properly seated, proceed to Para. 3.6.

### 3.6 Cabinet-to-Bracket Attachment

Once all connections are made and the wires are seated within the channels at the rear, it is only necessary to attach the control panel to the wall-mounted bracket.

Refer to Figure 11 and proceed as follows:

- A. Hold the cabinet with its top slightly slanted toward yourself and align the trap at the bottom of the cabinet with the dual-prong catch at the bottom of the bracket.

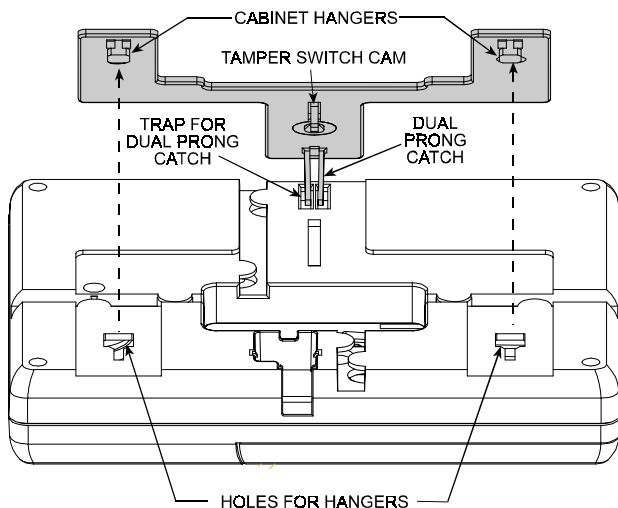

Figure 11. Cabinet-to-Bracket Assembly - Top View

- B. Allow the dual prong catch to enter the trap as far as it will go while slanting the cabinet towards your stomach.
- C. Using the dual prong catch as a pivot, bring the top of the cabinet closer to the wall, allowing the two hangers to enter the two corresponding holes in the cabinet.
- D. Once the cabinet is flush against the bracket, slide it down as far as the hangers will allow (about 10 mm). The dual prong catch at the bottom should snap into place with a click.

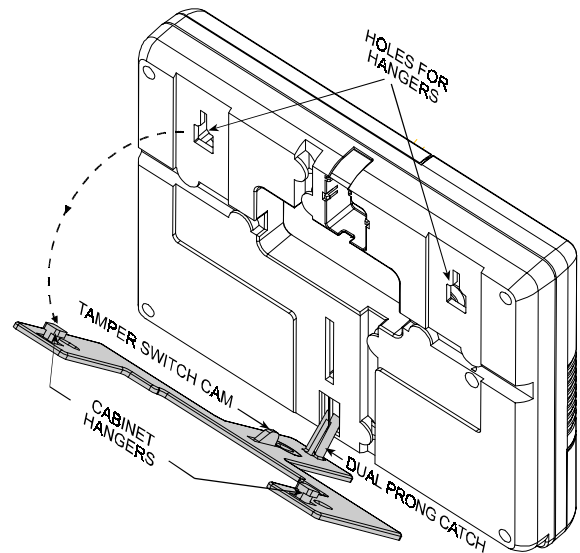

Figure 12. Cabinet-to-Bracket Assembly - Side View

- E. Pry the left side cover loose and remove it as explained in Para. 3.2, Steps A through C.
- F. You will find the bracket locking device in the open position shown in Figure 13, part A.
- G. Make sure that the screw is loose enough to allow shifting the lock down.
- H. Shift the lock down as shown by the arrow to reach the position viewed in part B and tighten the screw.

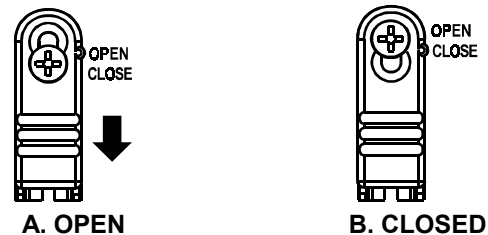

Figure 13. Locking the Bracket

- I. Test the assembly by lightly pulling the cabinet away from the wall. If correctly mounted, the cabinet will adhere to the bracket.

**Note:** See Para. 5.1 for dismounting procedure.

### 3.7 Connecting the AC Transformer

**CAUTION! Do not plug the transformer into the AC outlet before completing all other wiring.**

- A. **U.S.A. only:** Remove the center screw from the AC wall outlet.
- B. Plug the transformer directly in - the Power LED of the control panel should illuminate.
- C. **U.S.A. only:** Use the screw removed in Step A above to secure the transformer to the AC outlet. Tighten the screw well.
- D. The distance of the transformer from the system should not exceed 150 ft using 18 AWG conductors.

**For UL installations, do not connect to a receptacle controlled by a switch.**

### 3.8 PowerMax-Compatible Detectors

Each detector compatible with the PowerMax system is packed with its own installation instructions. Read them carefully and install as indicated.

#### A. PIR Motion Detectors

The wireless passive infrared (PIR) motion detectors used in the system are of the PowerCode type. The PowerMax

is capable of “learning” each detector’s identification code and linking it to a specific zone (see Section 3 in the Programming Manual). Some units are shown below:

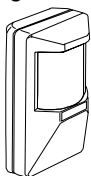

Figure 14.  
MC PIR-2000

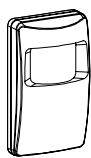

Figure 15. MC PIR-3000  
or K-940 MCW

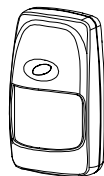

Figure 16.  
K-980MCW

**MC PIR-2000 & MC PIR-3000 are not UL-listed!**

**Note:** K-940 MCW and K-980MCW are pet immune units.

In addition to its unique 24-bit identification code, each detector transmits a message, containing status information:

- The detector is in alarm (or not).
- The detector is being tampered with (or not).
- The battery voltage is low (or normal).
- “This is a supervisory message”.

If any of these detectors detects motion, it sends out a message to the alarm control panel. If the system is in the armed state, an alarm will be triggered.

### B. Magnetic Contact Transmitter

MCT-302 (Figure 17) is a PowerCode magnetic-contact transmitter used to detect the opening of a door or a window. The alarm contacts are closed as long as the door or window remain closed.

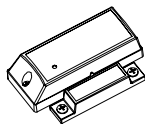

Figure 17.  
MCT-302

The unit has an extra alarm input that acts as if it were a separate wireless transmitter. It sends (or does not send) a “restored to normal” message to the alarm system, depending on the setting of an on-board “DIP” switch. The “restore” message informs you, through the control panel’s display, whether the door or window is open or closed.

### C. MCT-100 Wireless Adapter for Wired Detectors

(not UL-Listed) MCT-100 (Fig. 18) is a PowerCode device used mainly as a wireless adapter for 2 regular magnetic switches installed on 2 windows in the same room. It has two inputs, behaving as separate wireless transmitters with different PowerCode IDs. Each input sends (or does not send) a “restored” message to the alarm system, depending on the setting of an on-board “DIP” switch.

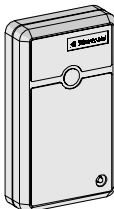

Figure 18.  
MCT-100

### D. Wireless Smoke Detector

**MCT-423 (not UL-listed).** A photoelectric smoke detector equipped with a PowerCode-type transmitter. If enrolled to a fire zone, it initiates a fire alarm upon detection of smoke.

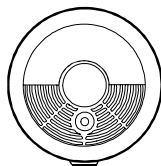

Figure 19. MCT-423

### E. Glass Break Detector MCT-501

(not UL-Listed). An acoustic detector (Fig. 20) equipped with a PowerCode-type transmitter. Since it restores automatically after detection, this unit does not send a restoral message to the control panel.

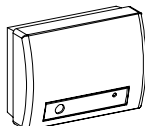

Figure 20.  
MCT-501

## 3.9 PowerMax-Compatible Transmitters

**Note:** Each transmitter is packed with its own instructions for battery installation and use. Be sure to pass these documents on to the “Master User” of the alarm system.

The PowerMax system is compatible with multi-button and

single button key-ring and hand-held transmitters that use PowerCode and CodeSecure coding methods.

Multi-button PowerCode transmitters transmit the same code each time the same button is pressed. They can be used for emergency signaling, or for activating the PGM output or for controlling appliances via X-10 units. **They can not be used for arming / disarming.**

CodeSecure transmitters are of the rolling code type - they transmit a new code each time the same button is pressed. This provides a higher security level, especially in arming / disarming applications, because the code can not be copied (“grabbed”) by unauthorized people.

Following are the basic details of several compatible transmitters. The possible applications for each push-button are indicated in each drawing.

**A. MCT-234** (Fig 21): ‘Keyfob’ transmitter - one unit is supplied with the PowerMax. You can program the AUX (auxiliary) button to perform various tasks, in accordance with the user’s needs.

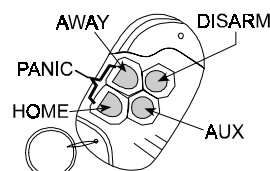

Figure 21. MCT-234

**B. MCT-231 / 201\*** (Fig. 22): Single-button pendant units. The MCT-231 (CodeSecure) and the MCT-201 (PowerCode) can be enrolled to perform functions as shown. Both units look alike.

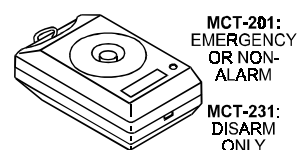

Figure 22. MCT-231 / 201

**C. MCT-134 / 104\*** (Fig. 23): 4-button hand-held units. MCT-134 (CodeSecure) can replace the MCT-234 keyfob. MCT-104 (PowerCode) can perform emergency and non-alarm functions. Both units look alike.

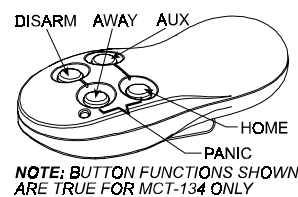

Figure 23. MCT-134 / 104

**D. MCT-132 / 102\*** (Fig. 24): 2-button units. MCT-132 (CodeSecure) Can perform functions as shown. MCT-102 (PowerCode) can perform emergency and non-alarm tasks. Both units look alike.

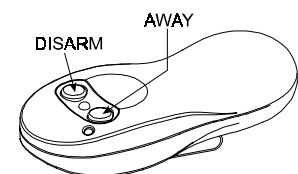

Figure 24. MCT-132 / 102

**E. MCT-131 / 101\*** (Fig. 25): Single-button units. The MCT-131 (CodeSecure) and the MCT-101 (PowerCode) can be enrolled to perform functions as shown. Both units look alike.



Figure 25. MCT-131 / 101

**F. MCT-211\*** (Fig. 26) Water-proof, wrist-worn PowerCode transmitter. Can be enrolled to perform emergency or non-alarm functions.

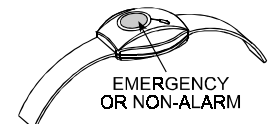

Figure 26. MCT-211

\* Not UL-listed - not to be used in UL-listed systems

## 3.10 Mounting the RS232 Module

The control panel can be equipped with an optional RS232 module for serial data interchange with a local computer. If this module is not supplied, a special plastic cap blocks the niche designed to accommodate the module.

The following instructions are useful when adding the

RS232 module to an already installed PowerMax system:

- A. Detach the cabinet from the bracket (see Para. 5.1)
- B. Remove the factory installed plastic cap by sliding it out along the grooves as shown in Figure 27.

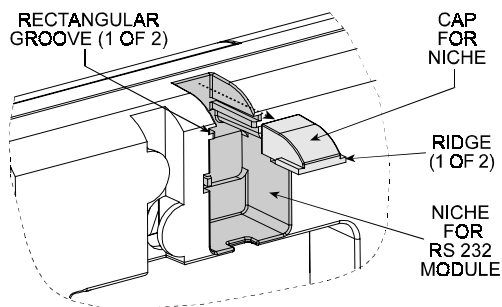

Figure 27. Removing the Cap from the RS232 Niche

- C. Align the RS232 module with the grooves and the module catches as shown in Figure 28.

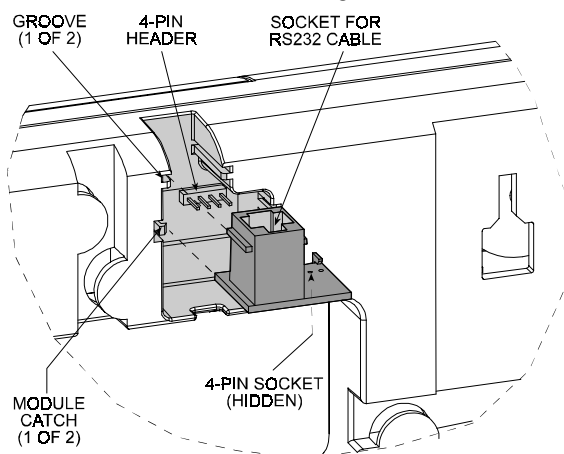

Figure 28. Inserting the RS232 Module

- D. Push the module all the way in, making sure that the 4-pin socket mates with the 4-pin header at the bottom.

**Note:** When the module is properly seated, the module catches pushed aside during insertion will spring back into place above the top edge of the module.

- E. Prepare an RS-232 flat modular cable and terminate it with a 6-position RJ-11 plug at the PowerMax end. Terminations at the computer's end may vary.
- F. Mate the plug with the RJ-11 socket and bend the cable backward to route it out via the wiring channel.
- G. Re-attach the control panel to the bracket, as instructed in Para. 3.6.

**Attention:** For data download from a local computer, the PowerMax must be set to the installer mode.

### 3.11 Installing an Optional X-10 Siren (not to be used in UL-listed systems)

If you need a "wireless" external siren, you may install an X-10 siren module which is triggered by a signal transmitted via the built-in electrical wiring of the protected site. This siren can replace the regular external siren or complement it without laying out additional wires. Of course, such a siren can be used only in conjunction with an optional power-line interface module.

The X-10 siren is ready to function upon connection to an electrical power outlet, without re-programming the PowerMax. You only have to set the HOUSE CODE and the UNIT CODE selectors on the X-10 siren as follows:

**House Code:** Set this selector to the letter that follows, by alphabetical order, the letter that you programmed as a house code for the protected premises. For example, if the programmed house code is "J", set the siren house code selector to "K".

**Note:** If the programmed house code letter is "P" (which is the last programmable letter), select "A" for the siren.

**Unit Code:** The siren will function only if you set the unit code selector to "1".

## 4. TESTING PROCEDURES

### 4.1 Preparations

Make sure all windows and doors are closed. If all zones are secured (undisturbed), the display should read:

READY      HH : MM

If the system is "NOT READY", query the control panel by pressing the <SHOW/OK> button repeatedly. The source(s) of the problem(s) will be displayed and read aloud. Take the necessary measures to eliminate the problem(s) before testing the system (see 4.2 below).

### 4.2 Diagnostic Test

A comprehensive diagnostic test is required for two reasons:

- To verify proper function of all detectors in the system.
- To assure that there is a safe 6 dB margin for signal reception.

To perform this test, you must access item No. 8 in the installer's menu exactly as done when programming the control panel:

- A. Click the <NEXT> button until the display reads:

INSTALLER MODE

- B. Click <OK> to select the installer's menu. The control panel will prompt you for the installer code.

- C. Enter the valid installer code (9→9→9→9) or the new installer code that you already programmed. The "Happy Tune" (- - - —) will sound if the code is correct and the display will change to:

1. NEW INSTL CODE

- D. Click <NEXT> or <BACK> until the number and name of the desired mode are displayed:

8. DIAGNOSTICS

- E. Carry on as in Section 9 of the programming guide.

### 4.3 Keyfob Transmitter Test

Initiate transmission from each transmitter enrolled as a keyfob unit (according to the list in Table A2, Appendix A). Use each transmitter to arm the control panel AWAY and immediately disarm it. Upon pressing the keyfob unit's AWAY key, the ARM indicator should light, and the display should respond as follows:

ARMING AWAY



PLEASE EXIT NOW

The exit delay beeps will begin.

Press the keyfob unit's DISARM (⏏) key. The ARM



indicator should extinguish, the “Happy Tune” (- - - —) should sound and the display should revert to:

READY HH : MM

Test the **AUX** button in each keyfob in accordance with the information noted in Table A.2, Appendix A. Verify that the **AUX** button performs its duty as programmed.

- If the AUX (\*) button is defined as “STATUS”, system status should be displayed and announced upon pressing the button.
- If the AUX (\*) button is defined as “INSTANT”, press the AWAY button and then the AUX button. The response should be:

ARMING INSTANT

↶ (alternating) ↷

PLEASE EXIT NOW

and the exit delay beeps will start. Press the DISARM (Ⓜ) key immediately to disarm.

- If the AUX (\*) button is programmed as “PGM / X-10” and permitted to activate one or several X-10 units, pressing (\*) should activate the appliance controlled by the chosen X-10 unit(s).
- If the AUX (\*) button is programmed as “PGM / X-10” and permitted to activate the PGM output, pressing (\*) should activate the device wired to the PGM output.

#### 4.4 Appliance ON/OFF Test

The “X-10 unit assignment” information that you noted in Appendix B to this manual is very useful for this test.

Go over the table in **Appendix B** column by column. If, for instance the “ON by arming” column has “X”s marked in the rows pertaining to units 1, 5 and 7 - then arm the system and verify that the appliances controlled by these units are actually activated upon arming.

Continue in the same manner in the following columns, always creating the state or event that will activate the relevant units. Verify that all appliances are activated as programmed.

**IMPORTANT!** Before testing “On by Timer” and “On by Zone”, make sure that these forms of control are permitted - click  repeatedly and verify that the display shows:

BY TIMER ON

and:

BY SENSOR ON

A dark box at the extreme right means that these functions are enabled.

The easiest way to test timed activation is to select the ninth item in the installer’s menu (“9. USER SETTINGS”) and set the system clock a few minutes before the relevant “start time”. Do not forget to return the clock to the correct time after completion of this test.

#### 4.5 Emergency Transmitter Test

Initiate transmission from each transmitter enrolled to an emergency zone (according to the list in Table A3, Appendix A). For example, upon pressing the transmit button of an emergency transmitter enrolled to zone 22, the display should read:

Z 22 EMERGENCY

↶ (alternating) ↷

VIOLATED

It is advisable to let the central station know that you are conducting this test, or just disconnect the telephone line from the PowerMax during the test, to prevent false alarms.

## 5. MAINTENANCE

### 5.1 Dismounting the Control Panel

- Pry the left side cover loose and remove it carefully as explained in Para. 3.2, Steps A through C.
- You will probably find the bracket locking device in the **closed** position (see Figure 29, part A).
- Loosen the screw until the lock can be shifted.
- Shift the lock up as shown by the arrow to reach the **open** position as in part B and tighten the screw.

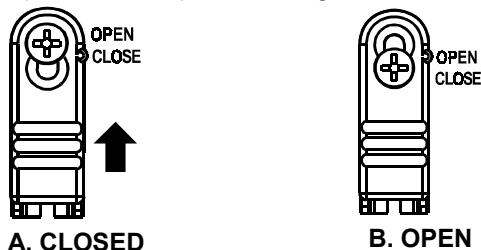

Figure 29. Unlocking the Bracket

- Insert the bracket release key, supplied with the PowerMax kit, as far as it will go into the hole at the bottom of the unit (see Figure 30). This action frees the catch from the trap.

- Slide the control panel about 10 mm up along the bracket.
- After sliding the cabinet up, remove the plastic key and pull the upper part of the cabinet away from the bracket, slanting it towards yourself.
- With the cabinet free of the hangers you can pull the bottom of the cabinet away and free it from the dual prong catch at the bottom of the bracket.

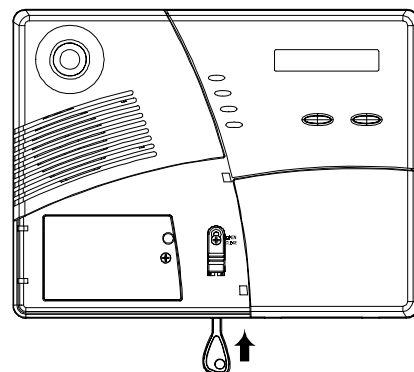
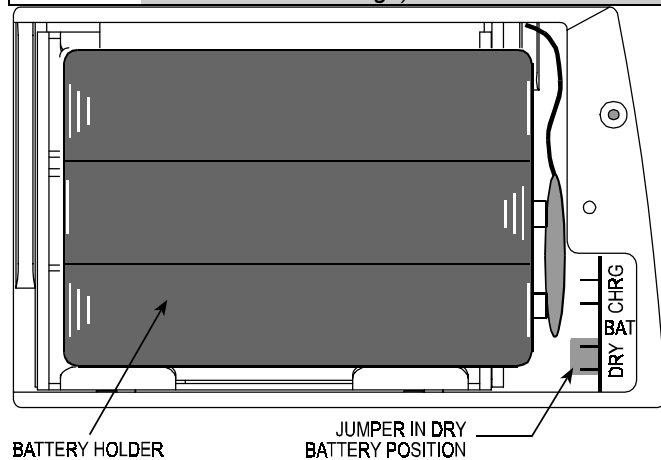
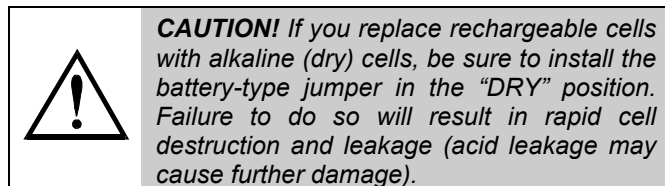

Figure 30. Releasing the Catch

## 5.2 Replacing the Backup Battery



**Figure 31. Jumper in Dry Battery Position**

Replacement and first-time insertion of cells are similar (see Para. 3.2). The only difference is the necessity to remove the old cells and to inspect the battery holder contacts and springs for signs of corrosion.

If corrosion is found in the battery holder, clean it first with a piece of cloth dampened with hot water and then file the contacts clean until they shine. In extreme cases, the entire battery holder should be replaced.

With fresh battery cells, correct insertion and tightened battery compartment lid, the TROUBLE indicator should extinguish. However, the "MEMORY" message will now blink in the display (caused by the "tamper" alarm you triggered when opening the battery compartment lid). Clear it by arming the system and immediately disarming.

## 5.3 Fuse Replacement

The PowerMax has two fuses which can burn out:

- Battery Fuse - 1A, time delay type, UL recognized (exists in U.S. variants only).
- Siren Fuse - 0.5 A, time delay type, UL recognized (in the U.S.A.) or 0.5 A, time delay type, per IEC127-3 (in Europe).

If any one of the fuses burns out (in U.S.A. variants) or the siren fuse burns out (in other variants), the trouble indicator lights and TRBL is displayed (together with READY or NOT READY - as the case may be). Clicking the <SHOW IOK> button will display a FUSE TROUBLE message.

The fuse(s) is (are) accessible through the rectangular opening at the rear of the cabinet (see figure 32). To replace a fuse, the cabinet should be temporarily dismantled (as described in Para. 5.1 above).

Extract the suspected fuse and check it visually. In most cases, a defective fuse can be identified by the broken conductor within the glass cylinder. If in doubt, test the continuity of the fuse with an ohmmeter.

Replace a defective fuse with a new one of the same ratings. The relevant trouble indications will immediately disappear.

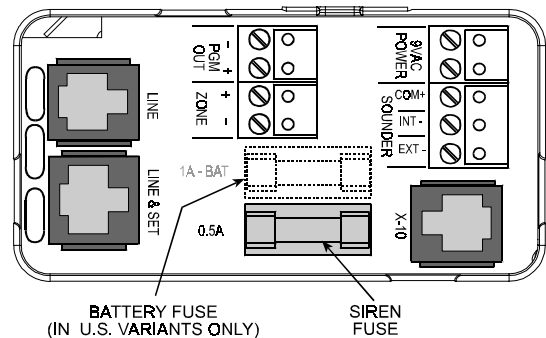

**Figure 32. Fuse Locations**

## 5.4 Replacing/Relocating Detectors

Whenever the maintenance work involves replacement or re-location of detectors, you must keep in mind the requirement to provide a 6 dB safety margin for signal reception. **It is therefore mandatory to perform a full diagnostic test per Section 9 of the Programming Guide.**

**Remember!** A "poor" signal is not acceptable, as stated at the end of the test procedure.

# APPENDIX A. Detector Deployment & Transmitter Assignments

## A1. Detector Deployment Plan

Zone No.	Zone Type	Sensor Location or Transmitter Assignment (in non-alarm or emergency zones)	Chime (Yes / No)	Controls PGM (X = YES)	Controls X-10 Unit No.
1					
2					
3					
4					
5					
6					
7					
8					
9					
10					
11					
12					
13					
14					
15					
16					
17					
18					
19					
20					
21					
22					
23					
24					
25					
26					
27					
28					
29					
30					

**Zone Types:** 1 = Interior \* 2 = Perimeter \* 3 = Delay 1 \* 4 = Delay 2 \* 5 = 24 h silent \* 6 = 24 h audible \* 7 = Fire \* 8 = Non-alarm \* 9 = Emergency.

**Zone Locations:** Note down the intended location for each detector. When programming, you may select one of 26 available zone names (plus 3 custom zone names that you can add - see Figure 3 in the Programming Guide).

## A2. Keyfob Transmitter List

Transmitter Data			AUX button Assignments		
No.	Type	Holder	Status or Arming "instant"	PGM Control	X-10 Unit Control
1			Indicate the desired function (if any) - see Para. 5.16 in the programming guide.  System status <input type="checkbox"/> Arming "instant" <input type="checkbox"/>	Indicate whether this output will be activated or not - see Section 7 in the programming guide.  Yes <input type="checkbox"/> No <input type="checkbox"/>	Mark the boxes of the X-10 units to be activated - see Section 7 in the programming guide.  1 <input type="checkbox"/> 2 <input type="checkbox"/> 3 <input type="checkbox"/> 4 <input type="checkbox"/> 5 <input type="checkbox"/> 6 <input type="checkbox"/> 7 <input type="checkbox"/>
2					
3					
4					
5					
6					
7					
8					

### A3. Emergency Transmitter List

Tx #	Transmitter Type	Enrolled to Zone	Name of holder
1			
2			
3			
4			
5			
6			
7			
8			
9			
10			

### A4. Non-Alarm Transmitter List

Tx #	Transmitter Type	Enrolled to Zone	Name of holder	Assignment
1				
2				
3				
4				
5				
6				
7				
8				
9				
10				

## APPENDIX B. X-10 Unit Assignments

Unit No.	Controlled Appliance	ON by Arming	ON by Memory	ON by Delay	ON by Keyfob	ON by Timer		ON by Zone No.		
						ON Time	OFF Time	a	b	c
1										
2										
3										
4										
5										
6										
7										

# Federal Communications Commission (FCC) Statements

## FCC PART 15 STATEMENT

This device complies with Part 15 of the FCC Rules. Operation is subject to the following two conditions: (1) This device may not cause harmful interference, and (2) This device must accept any interference received, including interference that may cause undesired operation.

**WARNING! Changes or modifications to this unit not expressly approved by the party responsible for compliance could void the user's authority to operate the equipment.**

The digital circuits of this device has been tested and found to comply with the limits for a Class B digital device, pursuant to Part 15 of the FCC Rules. These limits are designed to provide reasonable protection against harmful interference in residential installations. This equipment generates, uses and can radiate radio frequency energy and, if not installed and used in accordance with the instructions, may cause harmful interference to radio and television reception. However, there is no guarantee that interference will not occur in a particular installation. If this device does cause such interference, which can be verified by turning the device off and on, the user is encouraged to eliminate the interference by one or more of the following measures:

- Re-orient or re-locate the receiving antenna.
- Increase the distance between the device and the receiver.
- Connect the device to an outlet on a circuit different from the one which supplies power to the receiver.
- Consult the dealer or an experienced radio/TV technician.

## FCC PART 68 STATEMENT

This equipment complies with Part 68 of the FCC rules. On the front cover of this equipment is a label that contains, among other information, the FCC registration number and ringer equivalence number (REN) for this equipment. If requested, this information must be provided to the telephone company.

This equipment uses the following jacks: An RJ31X is used to connect this equipment to the telephone network. The REN is used to determine the quantity of devices which may be connected to the telephone line. Excessive RENs on the telephone line may result in the devices not ringing in response to an incoming call. In most, but not all areas, the sum of the RENs should not exceed five (5.0). To be certain of the number of devices that may be connected to the line, as determined by the total RENs, contact the telephone company to determine the maximum REN for the calling area. If this equipment causes harm to the telephone network, the telephone company will notify you in advance that temporary discontinuance of service may be required. If advance notice is not practical, the telephone company will notify the customer as soon as possible. Also, you will be advised of your right to file a complaint with the FCC if you believe necessary. The telephone company may make changes in its facilities, equipment, operations, or procedures that could affect the operation of the equipment. If this happens, the telephone company will provide advance notice that will enable you to make the necessary modifications in order to maintain uninterrupted service.

If trouble is experienced with this equipment, please contact the manufacturer for repair and warranty information. If the trouble is causing harm to the telephone network, the telephone company may request that you remove the equipment from the network until the problem is resolved.

There are no user serviceable components in this product, and all necessary repairs must be made by the manufacturer. Other repair methods may invalidate the FCC registration on this product.

This equipment cannot be used on telephone company-provided coin service. Connection to Party Line Service is subject to state tariffs.

When programming or making test calls to an emergency number, briefly explain to the dispatcher the reason for the call. Perform such activities in the off-peak hours; such as early morning or late evening.

## Declaration of Conformity

We, the undersigned,

Company: <b>Visonic Ltd</b>
Address: <b>30, Habarzel Street. , Tel-Aviv 61220</b>
Country: <b>Israel</b>
Telephone number: <b>+972 3 6456789</b>
Fax number: <b>+972 3 6456788</b>

certify and declare under our sole responsibility that the following equipment:

Type	Product description / Supplementary info
POWERMAX	Wireless burglar alarm control panel

is tested to and conforms with the essential EMC Requirements:

Standard	Issue date
EN 50081-1 EMC Emission	1992
EN 55022 RFI	1998
EN 50082-1 EMC Immunity	1997
EN 6100-4-6 EMC immunity to conducted RF	1996
TBR21 Telephony	1998
EN 60950+ Am1(93), Am2(93), Am3(95), Am4(97) Safety	1997

and therefore complies with the essential requirements and provisions of the **Directive 1999/5/EC** of the European Parliament and of the council of 9 march 1999 on Radio equipment and Telecommunications Terminal Equipment and the mutual recognition of their conformity and Annex III (Conformity Assessment procedure referred to in article 10(4)).

The following Notified Bodies and/or independent laboratories have been consulted in the Conformity Assessment procedure:

Notified Body number/Lab	Name and address
0122	NMi Certin B.V., POB 15, 9822 ZG Niekerk, The Netherlands

The technical documentation as required by the Conformity Assessment procedure is kept at the following address:

Company: <b>Visonic Ltd.</b>
Address: <b>Unit 1, Stratton Park Dunton Lane, Biggleswade Bedfordshire SG18 8QS</b>
Country: <b>UK</b>
Telephone number: <b>01767 600857</b>
Fax number: <b>0167 601098</b>

Drawn up in:

Tel-Aviv, Israel on

22/06/2000

(place)

(dd-mm-yy)

(signature)

**Yaacov  
Kotlicki  
Directing**

**Manager**  
(name and  
function)

(company  
stamp)



## WARRANTY

Visonic Ltd. and/or its subsidiaries and its affiliates ("the Manufacturer") warrants its products hereinafter referred to as "the Product" or "Products" to be in conformance with its own plans and specifications and to be free of defects in materials and workmanship under normal use and service for a period of twelve months from the date of shipment by the Manufacturer. The Manufacturer's obligations shall be limited within the warranty period, at its option, to repair or replace the product or any part thereof. The Manufacturer shall not be responsible for dismantling and/or reinstallation charges. To exercise the warranty the product must be returned to the Manufacturer freight prepaid and insured.

**This warranty does not apply in the following cases:** improper installation, misuse, failure to follow installation and operating instructions, alteration, abuse, accident or tampering, and repair by anyone other than the Manufacturer.

This warranty is exclusive and expressly in lieu of all other warranties, obligations or liabilities, whether written, oral, express or implied, including any warranty of merchantability or fitness for a particular purpose, or otherwise. In no case shall the Manufacturer be liable to anyone for any consequential or incidental damages for breach of this warranty or any other warranties whatsoever, as aforesaid.

This warranty shall not be modified, varied or extended, and the Manufacturer does not authorize any person to act on its behalf in the modification, variation or extension of this warranty. This warranty shall apply to the Product only. All products, accessories or attachments of others used in conjunction with the Product, including batteries, shall be covered solely by their own warranty, if any. The Manufacturer shall not be liable for any damage or loss whatsoever, whether directly, indirectly, incidentally, consequentially or otherwise, caused by the malfunction of the Product due to products, accessories, or attachments of others, including batteries, used in conjunction with the Products.

The Manufacturer does not represent that its Product may not be compromised and/or circumvented, or that the Product will prevent any death, personal and/or bodily injury and/or damage to property resulting from burglary, robbery, fire or otherwise, or that the Product will in all cases provide adequate warning or protection. User understands that a properly installed and maintained alarm may only reduce the risk of events such as burglary, robbery, and fire without warning, but it is not insurance or a guarantee that such will not occur or that there will be no death, personal damage and/or damage to property as a result.

**The Manufacturer shall have no liability for any death, personal and/or bodily injury and/or damage to property or other loss whether direct, indirect, incidental, consequential or otherwise, based on a claim that the Product failed to function.** However, if the Manufacturer is held liable, whether directly or indirectly, for any loss or damage arising under this limited warranty or otherwise, regardless of cause or origin, the Manufacturer's maximum liability shall not in any case exceed the purchase price of the Product, which shall be fixed as liquidated damages and not as a penalty, and shall be the complete and exclusive remedy against the Manufacturer.

**Warning:** The user should follow the installation and operation instructions and among other things test the Product and the whole system at least once a week. For various reasons, including, but not limited to, changes in environmental conditions, electric or electronic disruptions and tampering, the Product may not perform as expected. The user is advised to take all necessary precautions for his /her safety and the protection of his/her property.

6/91



VISONIC LTD. (ISRAEL): P.O.B 22020 TEL-AVIV 61220 ISRAEL. PHONE: (972-3) 645-6789, FAX: (972-3) 645-6788  
VISONIC INC. (U.S.A.): 10 NORTHWOOD DRIVE, BLOOMFIELD CT. 06002-1911. PHONE: (860) 243-0833, (800) 223-0020. FAX: (860) 242-8094  
VISONIC LTD. (UK): FRASER ROAD, PRIORY BUSINESS PARK, BEDFORD MK44 3WH. PHONE: (0870) 730-0800 FAX: (0870) 730-0801  
INTERNET: [www.visonic.com](http://www.visonic.com)

©VISONIC LTD. 2002 POWERMAX DE5450- (REV. 4, 04/02)



MADE IN  
ISRAEL