

**BLOOMFIELD INDUSTRIES**

2 ERIK CIRCLE, P. O. Box 280  
Verdi, NV 89439  
telephone: 775-689-5700  
fax: 888-492-2783  
[www.wellsbloomfield.com](http://www.wellsbloomfield.com)



*Model 9311 Satellite Brewer  
w/optional  
3902 Drip Tray*

**OWNERS MANUAL  
for  
SS1 - SERIES  
SATELLITE  
COFFEE BREWERS  
with  
ELECTRO-MECHANICAL  
CONTROL  
and  
INTERNALLY HEATED  
SATELLITE SERVER**

**MODEL:  
9311**

**Includes:**

**Installation  
Operation  
Use & Care  
Servicing Instructions**

PRINTED IN UNITED STATES OF AMERICA

## WARRANTY STATEMENT

All electrical equipment manufactured by BLOOMFIELD INDUSTRIES is warranted against defects in materials and workmanship for a period of one year from the date of original installation or eighteen (18) months from the date of shipment from our factory, whichever comes first, and is for the benefit of the original purchaser, except that:

- a. airpots carry a 30 day parts warranty only.
- b. dispensers; i.e., tea and coffee carry a 90 days parts warranty only, excludes decanters.

THE FOREGOING OBLIGATION IS EXPRESSLY GIVEN IN LIEU OF ANY OTHER WARRANTIES, EXPRESSED OR IMPLIED, INCLUDING ANY IMPLIED WARRANTY OF MERCHANTABILITY OR FITNESS FOR A PARTICULAR PURPOSE, WHICH ARE HEREBY EXCLUDED.

BLOOMFIELD INDUSTRIES DIVISION / SPECIALTY EQUIPMENT MANUFACTURING CORPORATION SHALL NOT BE LIABLE FOR INDIRECT, INCIDENTAL OR CONSEQUENTIAL DAMAGES OR LOSSES FROM ANY CAUSE WHATSOEVER.

This warranty is void if it is determined that upon inspection by an Authorized Service Agency that the equipment has been modified, misused, misapplied, improperly installed, or damaged in transit or by fire, flood or act of God.

It also does not apply if the serial nameplate has been removed or unauthorized service personnel perform service. The prices charged by Bloomfield Industries for its products are based upon the limitations in this warranty. Seller's obligation under this warranty is limited to the repair of defects without charge by a Bloomfield Industries Authorized Service Agency or one of its sub-agencies. This service will be provided on customer's premises for non-portable models. Portable models (a device with a cord and plug) must be taken or shipped to the closest Authorized Service Agency, transportation charges prepaid, for services.

In addition to restrictions contained in this warranty, specific limitations are shown below (Additional Warranty Exclusions). Bloomfield Industries Authorized Service Agencies are located in principal cities.

This warranty is valid in the United States and void elsewhere. Please consult your classified telephone directory or your food service equipment dealer; or, for information and other details concerning warranty, write to:

**Service Parts Department  
Bloomfield Industries  
P.O. Box 280  
Verdi, NV 89439**

**Phone: (888) 4929-2782 Fax: (888) 492-2783**

## SERVICE POLICY AND PROCEDURE GUIDE ADDITIONAL WARRANTY EXCLUSIONS

1. Resetting of safety thermostats, circuit breakers, overload protectors, or fuse replacements unless warranted conditions are the cause.
2. All problems due to operation at voltages other than specified on equipment nameplates; conversion to correct voltage must be the customer's responsibility.
3. All problems due to electrical connections not made in accordance with electrical code requirements and wiring diagrams supplied with the equipment.
4. Replacement of items subject to normal wear, to include such items as knobs and light bulbs. Normal maintenance functions including adjustment of thermostats, microswitches, and replacement of fuses and indicating lights are not covered under warranty.
5. All problems due to inadequate water supply, such as fluctuating, or high or low water pressure.
6. All problems due to mineral/calcium deposits, or contamination from chlorides/chlorines. De-liming is considered a preventative maintenance function and is not covered by warranty.
7. Full use, care and maintenance instructions are supplied with each machine. Those miscellaneous adjustments noted are customer responsibility. Proper attention will prolong the life of the machine.
8. Travel mileage is limited to sixty (60) miles from an authorized Service Agency or one of its sub-agencies.
9. All labor shall be performed during normal working hours. Overtime premium shall be charged to the customer.
10. All genuine Bloomfield replacement parts are warranted for ninety (90) days from date of purchase on non-warranted equipment. **Any use of non-genuine Bloomfield parts completely voids any warranty.**
11. Installation, labor and job check-out are not considered warranty.
12. Charges incurred by delays, waiting time or operating restrictions that hinder the service technicians ability to perform services are not covered by warranty. This includes institutional and correctional facilities.

## SHIPPING DAMAGE CLAIMS PROCEDURE

**NOTE:** For your protection, please note that equipment in this shipment was carefully inspected and packaged by skilled personnel before leaving the factory. Upon acceptance of this shipment, the transportation company assumes full responsibility for its safe delivery.

### IF SHIPMENT ARRIVES DAMAGED:

1. **VISIBLE LOSS OR DAMAGE:** Be certain that any visible loss or damage is noted on the freight bill or express receipt, and that the note of loss or damage is signed by the delivery person.
2. **FILE CLAIM FOR DAMAGE IMMEDIATELY:** Regardless of the extent of the damage.

3. **CONCEALED LOSS OR DAMAGE:** if damage is unnoticed until the merchandise is unpacked, notify the transportation company or carrier immediately, and file "CONCEALED DAMAGE" claim with them. This must be done within fifteen (15) days from the date the delivery was made to you. Be sure to retain the container for inspection.

Bloomfield Industries cannot assume liability for damage or loss incurred in transit. We will, however, at your request, supply you with the necessary documents to support your claim.

## TABLE OF CONTENTS

WARRANTY STATEMENT	xi
SPECIFICATIONS	1
FEATURES & OPERATING CONTROLS	2
PRECAUTIONS & GENERAL INFORMATION	4
AGENCY APPROVAL INFORMATION	4
INSTALLATION	5
OPERATION	7
CLEANING INSTRUCTIONS	9
SERVICING INSTRUCTIONS	11
TROUBLESHOOTING SUGGESTIONS	16
EXPLODED VIEW	18
WIRING DIAGRAM	20
SATELLITE	21

Thank You for purchasing this Bloomfield Industries appliance.

Proper installation, professional operation and consistent maintenance of this appliance will ensure that it gives you the very best performance and a long, economical service life.

This manual contains the information needed to properly install this appliance, and to use, care for and maintain or repair the appliance in a manner which will ensure its optimum performance.

## SPECIFICATIONS

MODEL	VOLTS	WATTS	AMPS	POWER CORD
9311	120/208 - 240 VAC 60 Hz 1ø	3200 - 4280W	15.4 - 17.8A	3-wire required (L1, L2, Neut) + Gnd Cord NOT Provided

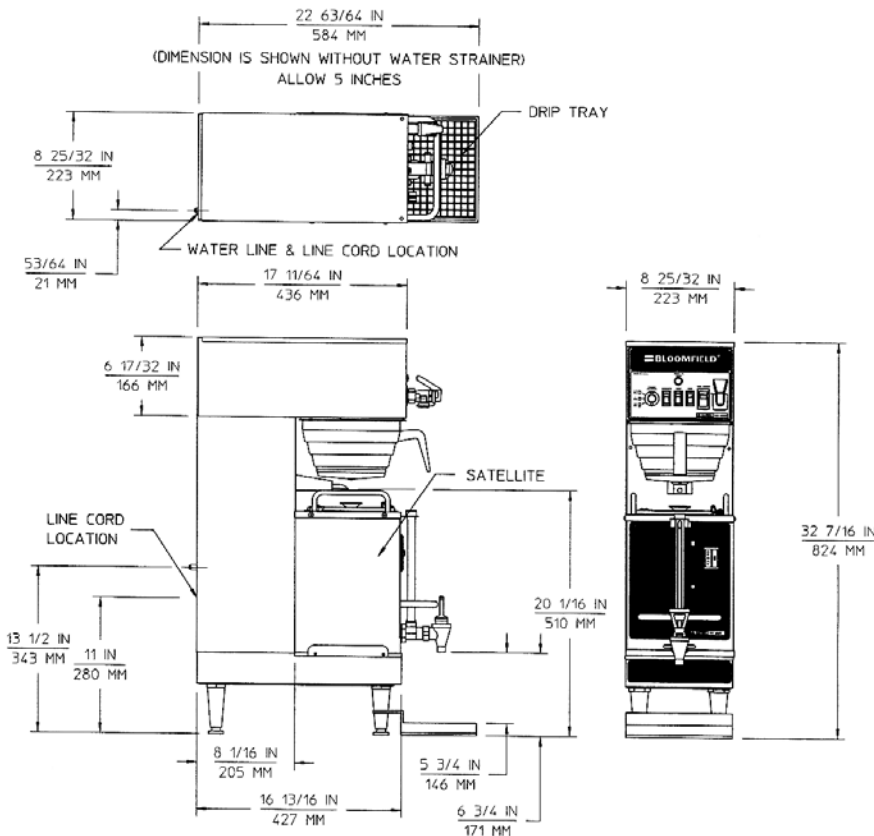

661 74415 9311 Single Satellite Brewer

# FEATURES AND OPERATING CONTROLS

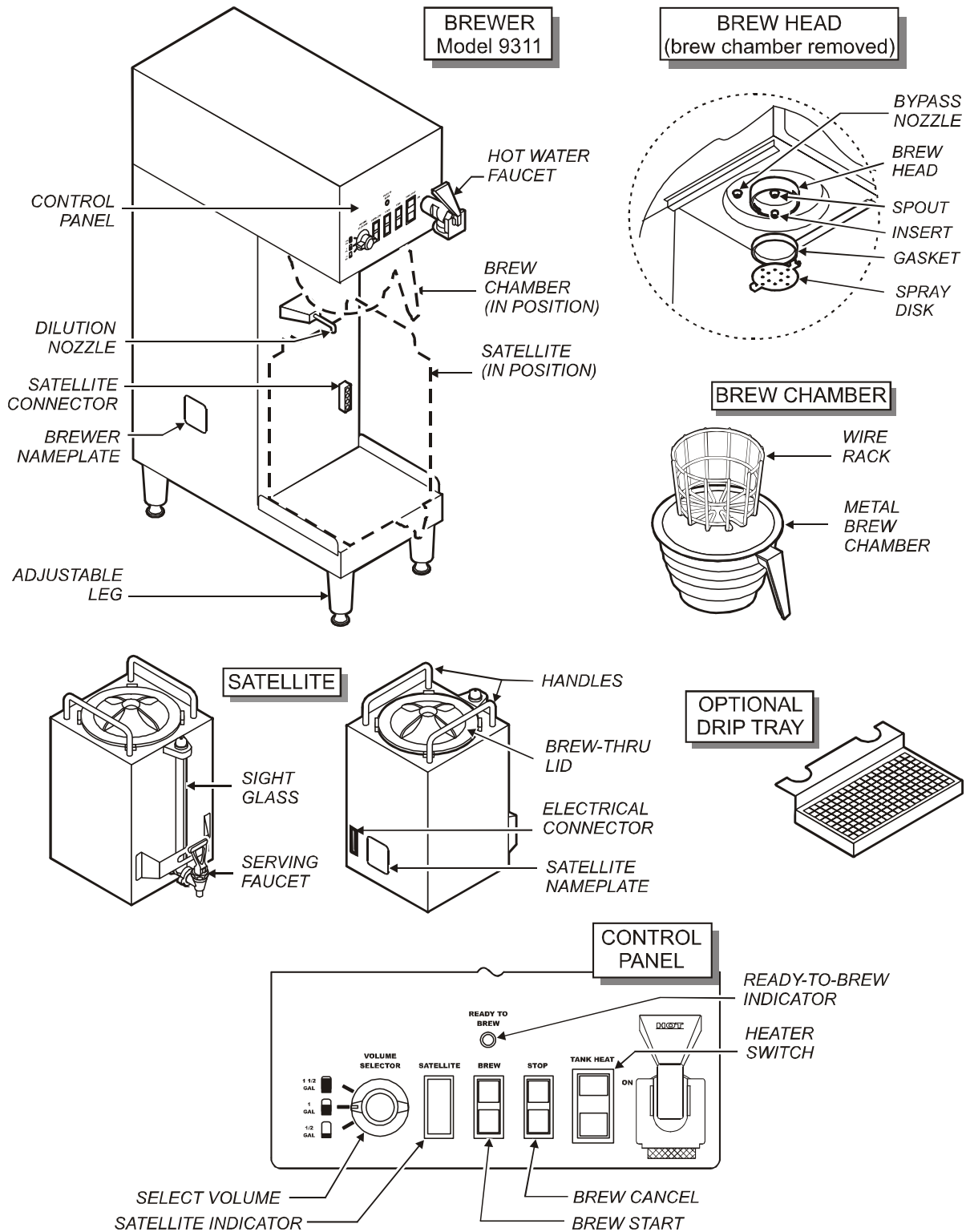

Fig 1. SS-1 Satellite Brewing System Features & Operating Controls

661 74415 9311 Single Satellite Brewer

## FEATURES AND OPERATING CONTROLS (continued)

### Brewer

Adjustable Legs	Allows brewer to be leveled. Also allow clearance for cleaning underneath brewer.
Bypass Nozzle	Dilution water flows into satellite server from here.
Connector	Connects to satellite. Allows satellite heater to be energized. Allows brewer to sense that a satellite is in place.
Hot Water Faucet	Hot water dispensed here.
Nameplate	Lists manufacturer, model and serial number. Also lists voltage and wattage rating of brewer.

### Control Panel

<i>Brew</i> Switch	Press to start a brew.
<i>Ready to Brew</i> Indicator	Glow when water in tank is up to temperature.
<i>Stop</i> Switch	Press to cancel a brew in progress.
<i>Satellite</i> Indicator	Glow when a satellite is properly installed. Flashes at end of Quality Time.
<i>Tank Heat</i> Switch	Applies power to tank heater element. Glows when <i>ON</i> .
<i>Volume Selector</i> Switch	Allows selection if 1/2 gallon, 1 gallon or 1-1/2 gallon brew.

### Brew Chamber

Brew Chamber	Holds coffee grounds during brew cycle.
Wire Rack	Holds paper filter and coffee grounds in proper position in brew chamber.

### Satellite

Brew-Thru Lid	Allows entry of brewed coffee and dilution water into satellite. Minimizes splashing in the event satellite is tipped.
Connector	Connects to brewer. Allows heater to be energized. Allows brewer to sense that a satellite is in place.
Handles	Allow the satellite to be safely carried.
Nameplate	Lists manufacturer, model and serial number. Also lists voltage and wattage rating of satellite.
Serving Faucet	Fresh coffee dispensed from satellite here.
Sight Glass	Check the level of coffee remaining here.

### Drip Tray (optional)

Optional drip tray catches drips and spills from serving faucet. Easily removed for cleaning.

## GENERAL INFORMATION AND PRECAUTIONS



### **WARNING:** **Electric** **Shock hazard**

All servicing requiring access to non-insulated electrical components must be performed by a factory authorized technician.  
DO NOT open any access panel which requires the use of tools. Failure to follow this warning can result in severe electrical shock.

This appliance is intended for use in commercial establishments only.

This appliance is intended to brew hot beverage, specifically coffee, for human consumption. No other use is recommended or authorized by the manufacturer or its agents.

Operators of this appliance must be familiar with the appliance use, limitations and associated restrictions. Operating instructions must be read and understood by all persons using or installing this appliance.

Cleanliness of this appliance is essential to good sanitation. Read and follow all included cleaning instructions and schedules to ensure the safety of the food product.

Surfaces of the brewer, brew chamber and satellite can be hot to the touch, and may cause burns on contact.

Disconnect the brewer from electrical power before performing any maintenance or servicing.

DO NOT submerge satellites in water.

DO NOT splash or pour water over, onto or into any controls, control panel or wiring.

Any procedure which requires the use of tools must be performed by a qualified technician.

This manual is considered to be a permanent part of the appliance. This manual and all supplied instructions, diagrams, schematics, parts breakdown illustrations, notices and labels must remain with the appliance if it is sold or moved to another location.

This appliance is made in the USA. Unless otherwise noted, this appliance has American sizes on all hardware.





### **CAUTION:** **Burn Hazard**

Surfaces of the brewer and brew chamber may be hot to the touch and can cause burns on contact.

## AGENCY APPROVAL INFORMATION



This dual satellite brewing system is  listed under E9253

and  listed under E9253.



This dual satellite brewing system meets NSF Standard 4 only when installed and maintained per the instructions in this manual.



## INSTALLATION INSTRUCTIONS

### INSTALL LEGS

The brewer is provided with adjustable legs and rubber feet. Be sure the legs are securely screwed into the base of the brewer, and that the rubber feet are properly installed.

### LEVEL THE UNIT

The adjustable legs allow the brewer to be leveled. Set the brewer in its ultimate operating location and check for level with a spirit level. Adjust the brewer for level from front-to-rear, and from side-to-side. Be sure all four feet rest firmly on the counter.

### PLUMBER'S INSTALLATION INSTRUCTIONS

#### IMPORTANT:

This equipment must be installed in accordance with the Basic Plumbing Code of the Building Officials and Code Administrators International (BOCA), and the Food Service Sanitation Manual of the Food and Drug Administration (FDA). Also, this equipment installation must comply with all local plumbing codes and ordinances.

#### IMPORTANT:

Brewer must be installed on a water line with a full-flow pressure between 20 psi and 90 psi.

**NOTE:** If water pressure varies greatly, or exceeds 90 psi at any time, a water pressure regulator must be installed. Plumbing installer must supply the regulator.

Brewer must be connected to a potable water supply. Bloomfield recommends not less than 1/4" copper tubing for installations of 12' or less, and not less than 3/8" copper tubing for installations exceeding 12'. Brewer must be connected to a COLD water line.

**NOTE:** DO NOT use a saddle tap for this water line connection.

A shut-off valve must be installed between the main water supply and the brewer. Plumbing installer must supply the shut-off valve. A 1/4-turn ball valve is recommended.

Bloomfield highly recommends the use of the provided water strainer to help prevent deposits in the brewing system.

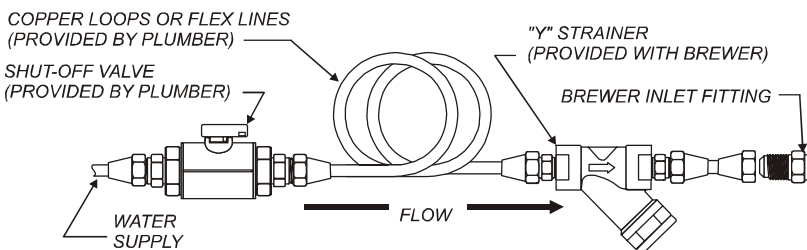

Fig. 3 Water Line Installation

Flush the water line before connecting to the brewer.



**CAUTION:**  
Hazard from  
Unstable Equipment

Rubber feet must be installed on each leg of the brewer. Legs must be adjusted so that all four feet rest firmly on the counter. Failure to properly install the feet can result in movement of the brewer, which can cause personal injury and/or damage to the brewer.

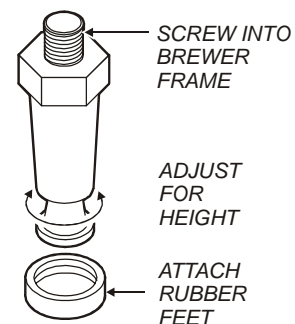

Fig. 2 Adjustable Legs

#### IMPORTANT:

In some areas, local codes require a backflow preventer (check valve) to be installed on the inlet water line. If a backflow preventer is used, you must install a **water hammer arrester** in the incoming line, between the backflow preventer and the brewer inlet, as far away from the brewer as space will allow. This will relieve the excessive back pressures that can cause faucet leaks and solenoid malfunctions.



## INSTALLATION INSTRUCTIONS (continued)



### **CAUTION:** Electric Shock Hazard

Brewer must be properly grounded to a reliable earth ground to prevent possible shock hazard. Do not assume a plumbing line will provide such a ground. Electrical shock may cause serious injury.

### **IMPORTANT:**

Initial set-up must be performed by a qualified installer or qualified service technician. Improper set-up will damage the brewer and void the warranty.

### **IMPORTANT:**

Complete water line installation before connecting brewer to electrical power.

### **MAKE SURE THE FRONT PANEL "TANK HEATER" SWITCH IS IN THE OFF POSITION BEFORE CONNECTING BREWER TO ELECTRICAL POWER.**

DO NOT turn the TANK HEATER switch on until the water tank is filled. Heating element must be completely submerged in water at all times. Damage to the brewer caused by operating the heating elements dry is NOT covered by warranty.

## **ELECTRICIAN'S INSTALLATION INSTRUCTIONS**

Refer to Electrical Specifications, page 1.

Brewer requires a dedicated single-phase circuit:

Model 9311 120/240 Volt AC, 50/60 Hz 4-Wire 20 Amps.

## **INITIAL SET-UP INSTRUCTIONS**

Plumber's and Electrician's installation procedures must be completed before proceeding with the set-up.

Be sure all electrical connections are secure, and that all plumbing connections are secure and leak-proof.

### **1. CHECK BREWER FOR PROPER CONFIGURATION**

Make sure spray disk gasket is in place **INSIDE** of spray head.

Make sure spray disk is properly installed.

Check hot water faucet for proper operation.

### **2. FILL WATER TANK**

Be sure TANK HEATER switch is **OFF**, then connect brewer to electric power.

Insert an empty brew chamber under the brew head. Place an empty satellite in position. Turn the VOLUME SELECTOR switch to 1 GAL.

Press **START**. Water will begin filling the tank. Repeat until water flows from the brew chamber. For initial start-up, tank requires two or more 1 GAL. cycles to fill.

### **3. CHECK HEATING**

Press TANK HEATER switch **ON**. Water in tank will heat to brewing temperature in approximately 30 minutes. When the water temperature reaches the brew temperature set point, the **READY-TO-BREW** light will glow.

Hold a suitable container under the hot water faucet, then open the faucet. Continue drawing water until all trapped air is expelled.



## OPERATING INSTRUCTIONS

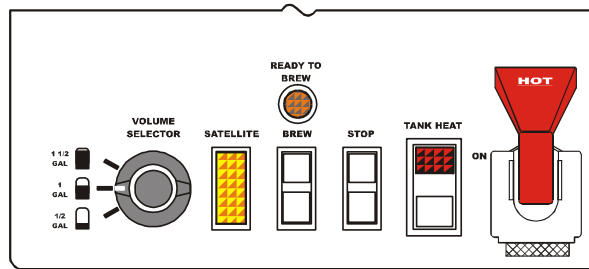

Fig. 4 Control Panel

### BREWING COFFEE

#### Prepare the Brew Basket:

Make sure the wire rack is properly installed in the brew chamber.

Insert one (1) Bloomfield paper filter into the brew chamber. Make sure the filter is properly supported by the wire rack.

Add a measured amount of grounds to the brew basket. Recommendations (may vary, depending on type of coffee and personal taste preferences):

To brew 1/2 gallon, use 2.25 oz (64 gm) of coffee

To brew 1 gallon, use 4.50 oz (128 gm) of coffee

To brew 1-1/2 gallon, use 8.40 oz (240 gm) of coffee

Gently shake the basket to level the grounds.

Slide the brew chamber under the brew head.

#### Insert the Satellite:

Brewer will not brew unless a satellite is properly installed. Slide satellite under the brew chamber until it is fully seated. The SATELLITE indicator will glow when the satellite is properly positioned.

#### Select Brew Volume:

Turn VOLUME SELECT switch to 1/2 GAL, 1 GAL or 1-1/2 GAL.

#### Start the Brew:

Press the **START** switch.

NOTE: The brew can be cancelled at any time by pressing the **STOP** switch.

At the end of the brew, be sure all water has stopped dripping before removing the brew chamber.

When the READY-TO-BREW light comes on, the brewer is ready to run another brew cycle.

#### Empty the Brew Basket:

Discard the grounds and the paper filter. Rinse the brew chamber under clear water.

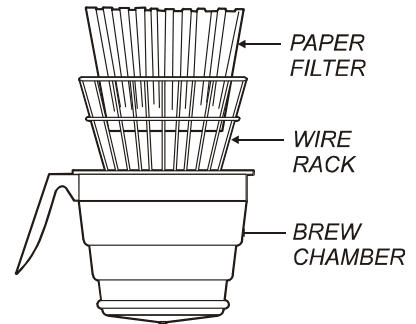

Fig. 5 Brew Basket

NOTE: Brewer will not brew unless a satellite is properly installed.

NOTE: The brew can be cancelled at any time by pressing the **STOP** switch.

NOTE: DO NOT turn the VOLUME SELECT switch during a brew. This will disrupt the brew cycle.



### CAUTION: Burn Hazard

Basket and contents are hot to the touch and may cause burns



## OPERATING INSTRUCTIONS (continued)

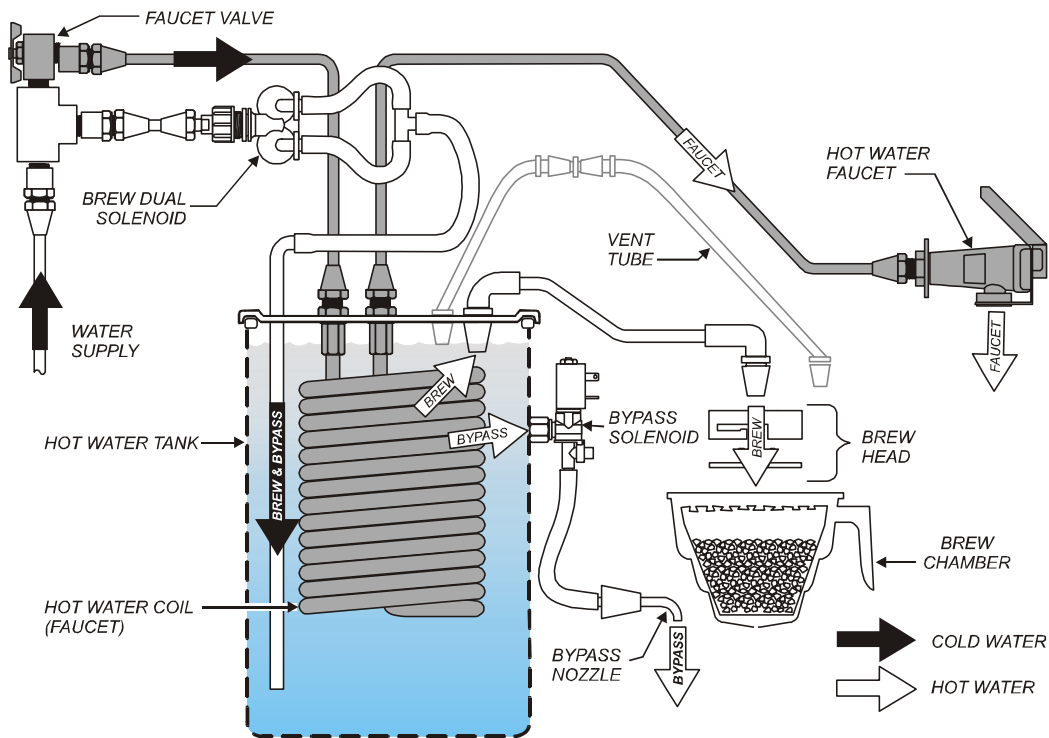

Fig. 6 Water Flow Diagram

The time the BREW SOLENOID is open is controlled by the TIMER in response to the position of the VOLUME SELECTOR switch.

The BREW SOLENOID has two sections:  
 .19 GPM (1/2 and 1 gal)  
 .33 GPM (1-1/2 gal)

**NOTE:** Use of the faucet will not affect the volume of water delivered for a brew. However, overuse of the faucet during a brew may lower the temperature of the brew water.

### BREW & BYPASS

The SS-1 is a modified displacement brewer.

For 1/2 and 1 gallon brews, there is no bypass. Water admitted into the hot water tank by the BREW SOLENOID will displace a like amount of heated water through the brew head, brew chamber and into the satellite.

In 1-1/2 gallon mode, a portion if the heated water is diverted to the satellite through the BYPASS SOLENOID and BYPASS NOZZLE.

The solenoid has two separately controlled sections to provide more precise control of delivered water volumes in bypass and non-bypass modes.

### HOT WATER FAUCET

Water for the hot water faucet is heated in a coil inside of the water tank. The faucet volume may be controlled by adjusting the FAUCET NEEDLE VALVE. Hot water is delivered at inlet line pressure and is approximately the same temperature as the brew water.

## CLEANING INSTRUCTIONS

### PROCEDURE: Clean Coffee Brewer

PRECAUTIONS: Press POWER key to OFF.  
Allow brewer to cool.

FREQUENCY: Daily

TOOLS: Mild Detergent, Clean Soft Cloth or Sponge  
Bristle Brush



### CAUTION: Burn Hazard

Brewing and serving temperatures of coffee are extremely hot. Hot coffee will cause serious skin burns.

1. Press POWER key to OFF.  
Allow brewer to cool.
2. Remove satellites.
3. Remove and empty brew baskets.
4. Remove spray disks and gaskets from spray heads
5. Wipe inside of spray head and area around spray head with a soft clean cloth or sponge moistened with clean water.
6. Wash spray disks in a sink using warm water and a mild detergent. A bristle brush may be used to clear clogged spray holes. Rinse spray disks with clean water and allow to air dry.
7. Wash brew baskets in a sink using warm water and a mild detergent. A bristle brush may be used to clean around the wire racks and bypass channels. Rinse with clean water and allow to air dry. Be sure wire racks are properly installed.
8. Remove and drain the drip tray. Rinse in a sink under warm running water. Allow to air dry, then reinstall on brewer.
9. Wipe exterior of brewer and satellites with a soft clean cloth or sponge moistened with clean water.
10. Reinstall gaskets INSIDE brew heads, then reinstall spray disks.
11. Reinstall brew chambers.
12. Reinstall satellites.

Procedure is complete

### IMPORTANT:

DO NOT use steel wool, sharp objects, or caustic, abrasive or chlorinated cleansers to clean the brewer, brew baskets or satellites.

DO NOT immerse or submerge satellites in water.

## CLEANING INSTRUCTIONS (continued)



### **CAUTION:** **Burn Hazard**

Brewing and serving temperatures of coffee are extremely hot. Hot coffee will cause serious skin burns.



### **WARNING:** **Electric Shock Hazard**

DO NOT immerse or submerge satellites. Fluid may saturate the insulation and short-circuit the receptacle connectors. Electric shock may cause injury and property damage.

### **IMPORTANT:**

DO NOT use steel wool, sharp objects, or caustic, abrasive or chlorinated cleansers to clean the satellites.

### **PROCEDURE: Clean Satellite**

PRECAUTIONS: Drain Satellite before Cleaning

FREQUENCY: Twice Weekly

TOOLS: Sight Glass Brush, Sanitizer  
Soft Clean Cloth, Bucket

1. Remove and drain satellites.
2. Place 1 packet of Sanitizer into 2-1/2 gallons of warm tap water. Pour approximately 1 gallon of sanitizer solution into each satellite. Allow to stand for 2 minutes.
3. Remove the shield cap (large vent) on top of the sight glass.

NOTE: It is not necessary to remove the sight glass unless it is broken and replacement is required.

4. Run the sight glass brush up and down through the sight glass at least 10 times.
5. Reinstall and tighten the shield cap.
6. Drain sanitizer solution from satellite into the bucket.
7. Disassemble faucet. Brush clean with sanitizer solution. Reassemble faucet.
8. Install satellite on brewer.
9. Rinse satellites: With an empty brew chamber in place, press the BREW key and run 1 full cycle into each satellite.
10. Drain water from satellites.

Procedure is complete

## SERVICING INSTRUCTIONS

### TEMPERATURE ADJUSTMENT

**PRECAUTIONS:** Disconnect brewer from electric power.  
Allow brewer to cool.

**FREQUENCY:** As required to adjust delivered volume

**TOOLS:** Phillips head screwdriver



**CAUTION:**  
SHOCK HAZARD

Live electrical circuits are exposed during this procedure. Use care to avoid uninsulated electrical connectors.

Adjustments to be performed by qualified technician only.

**NOTE:**  
1/8 turn = approx 10°F (5.5°C)

1. Press HEATER ON/OFF switch to *OFF*. Turn POWER switch on back of brewer *OFF*.
2. Remove TOP PANEL. Operating controls are accessible through the top panel only.
3. Remove vent tube from the tank cover and insert a thermometer of known accuracy.
4. Locate the CONTROL THERMOSTAT on the right side of the top housing:  
Turn *CLOCKWISE* to increase temperature  
Turn *COUNTER-CLOCKWISE* to decrease temperature  
1/8 turn is equal to approximately 10°F change.
5. Turn POWER switch *ON*. Press HEATER ON/OFF switch to *ON*.
6. Allow the brewer to come up to brewing temperature. When *READY-TO-BREW* light comes on, check temperature on thermometer. Readjust thermostat as necessary.

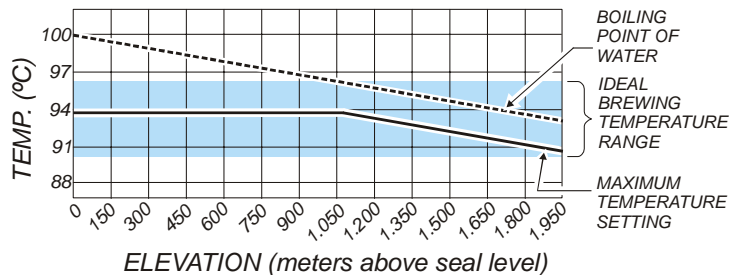
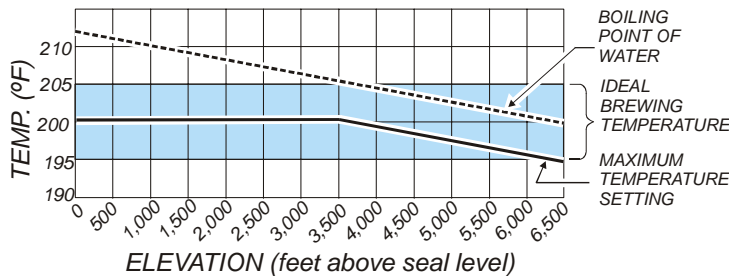
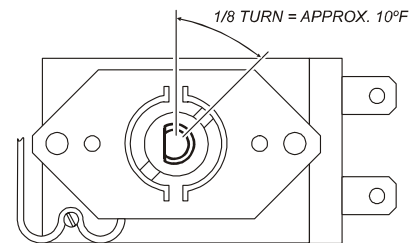

7. When desired temperature is achieved, remove thermometer, replace vent tube and reinstall top panel.

Procedure is complete

## SERVICING INSTRUCTIONS (continued)



### CAUTION: SHOCK HAZARD

Disconnect brewer from electric power before opening the access panel.

Adjustments to be performed by qualified technician only.

#### NOTE:

Brewer is pre-adjusted to deliver 1/2, 1 and 1-1/2 gallons of coffee at a water pressure of 50 p.s.i. Use this procedure to adjust the delivered volume to suit local conditions.

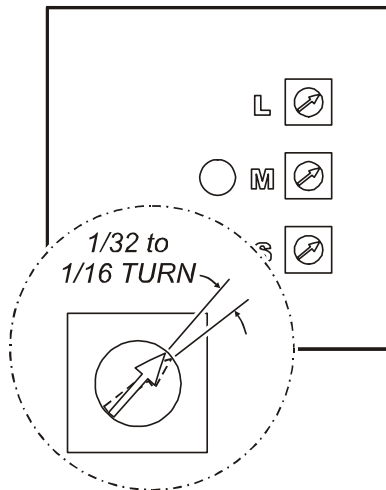

## BREW TIMER ADJUSTMENT

**PRECAUTIONS:** Disconnect brewer from electric power.  
Allow brewer to cool.

**FREQUENCY:** As required to adjust delivered volume

**TOOLS:** Phillips head screwdriver  
Small flathead screwdriver  
Satellite or other container to calibrate volume

1. Press HEATER ON/OFF switch to *OFF*. Disconnect brewer from electrical power.

2. Remove TOP PANEL. Operating controls are accessible through the top panel only.

3. Adjust the BREW TIMER setting.

**NOTE:** Each volume has its own setting:

L = 1-1/2 gallon (adjusts from 218 to 398 seconds)

M = 1 gallon (adjusts from 252 to 372 seconds)

S = 1/2 gallon (adjusts from 92 to 212 seconds)

Turn *CLOCKWISE* to increase time;

Turn *COUNTER-CLOCKWISE* to decrease time.

Adjust only in small increments to avoid large volume variations. Recommend adjustments be made in 1/32 turn increments, and no more than 1/16 turn at a time.

4. Replace TOP PANEL. Turn TANK HEATER switch *ON*. Reconnect brewer to electrical power.

5. Allow the brewer to come up to brewing temperature, then perform a test brew. Check delivered volume. Readjust as necessary.

When desired volume is achieved, procedure is complete.

## SERVICING INSTRUCTIONS (continued)

### QUALITY TIMER ADJUSTMENT

**PRECAUTIONS:** Disconnect brewer from electric power.  
Allow brewer to cool.

**FREQUENCY:** As required to adjust delivered volume

**TOOLS:** Phillips head screwdriver  
Satellite or other container to calibrate volume

1. Press HEATER ON/OFF switch to *OFF*. Disconnect brewer from electrical power.
2. Remove TOP PANEL. Operating controls are accessible through the top panel only.
3. Adjust the QUALITY TIMER setting.  
Turn *CLOCKWISE* to increase time;  
Turn *COUNTER-CLOCKWISE* to decrease time.  
Adjustment range is from 30 to 120 minutes.
4. Replace TOP PANEL. Turn TANK HEATER switch *ON*.  
Reconnect brewer to electrical power.

Procedure is complete



**CAUTION:**  
SHOCK HAZARD

Disconnect brewer from electric power before opening the access panel.

The QUALITY TIMER flashes the SATELLITE light at the end of the set interval to signal that the coffee has lost freshness. Discard the coffee in the satellite and either brew a fresh batch or clean the satellite for future use.

Quality time interval begins when the brew switch is pressed.

When the light is flashing, coffee will continue to be maintained at temperature until the satellite is removed from the brewer.

Removing the satellite for 5 seconds will reset the timer.

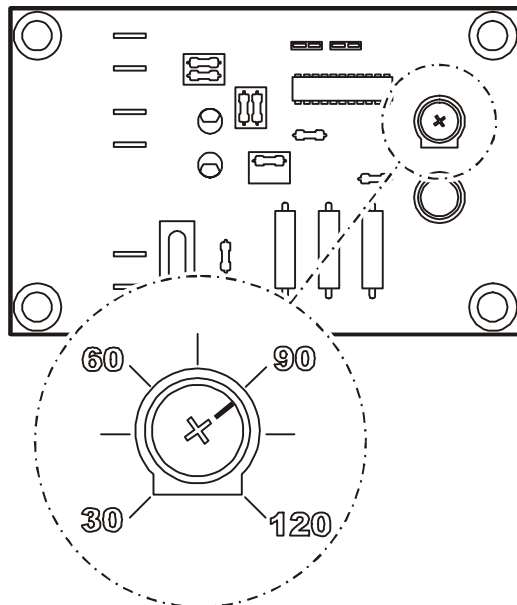



## SERVICING INSTRUCTIONS (continued)



### CAUTION - CHEMICAL BURN HAZARD

Deliming chemicals are caustic. Wear appropriate protective gloves and goggles during this procedure.

Never siphon deliming chemicals or solutions by mouth.

This operation should only be performed by qualified and experienced service personnel.

**IMPORTANT:** DO NOT spill, splash or pour water or deliming solution into or over any internal component other than the inside of the water tank.

**IMPORTANT:** DO NOT allow any internal components to come into contact with the deliming solution. Take care to keep all internal components dry.

**NOTE:** Repeat steps 4 and 7 as required to remove all build-up.

### PROCEDURE: Delime the Water Tank

**PRECAUTIONS:** Disconnect brewer from electric power. Allow brewer to cool.

**FREQUENCY:** As required (Brewer slow to heat)

**TOOLS:** Deliming Solution  
Protective Gloves, Goggles & Apron  
Mild Detergent, Clean Soft Cloth or Sponge  
Bristle Brush, Bottle Brush  
Large Sink (or other appropriate work area)

1. Disconnect brewer from the electrical supply.
2. Remove the brewer top panel, then remove the tank lid assembly. Do not disconnect the tank assembly at this time.
3. Siphon all water from the hot water tank.
4. Mix 10 gallons of deliming solution according to the manufacturer's directions. Carefully pour the deliming solution into the water tank. Lower the lid assembly back onto the tank. Allow to sit for 30 minutes, or as directed by the chemical manufacturer.
5. At end of soaking period, reconnect brewer to electrical power. Install the brew chamber without filter paper or grounds. Place an empty satellite under the brew chamber. Force a 1-1/2 gallon brew:
  - a. Press the 1-1/2 gallon key
  - b. Press the brew key, then press and hold the brew key until a brew is initiated.Empty the satellite and repeat for the other side.
6. Disconnect brewer from electrical power and allow to cool.
7. Remove lid assembly from tank.
  - a. Using a stiff bristle brush, scrub internal components to remove lime and calcium build-up.
  - b. Thoroughly rinse internal components of lid assembly with clear water.
  - c. Store lid assembly in a safe location.
8. Using a stiff bristle brush, scrub exposed portions of the heating element and the inside surfaces of the tank to remove lime and calcium build-up.
9. Siphon all solution from the tank.

## SERVICING INSTRUCTIONS (continued)

10. Reinstall tank lid assembly into hot water tank. Make sure the lid gasket is properly in place, then reinstall the hold-down clamps.
11. Remove spray disks and gaskets. Rinse both brew heads with clean water. Using a stiff brush, scrub spray disk to remove any lime or calcium build-up. Reinstall gaskets and spray disks.
13. Reconnect brewer to electrical supply .
14. Install the brew chamber without filter paper or grounds.
15. Place an empty satellite under the brew chamber. Run at least five 1-1/2 gallon brew cycles and discard all water generated at the end of each cycle. Repeat for the other side.
16. Rinse satellite with clean water. Reinstall one empty satellite under each brew chamber.

**NOTE:** Normally, silicone hoses do not need to be delimed. Should deliming hoses become necessary, Bloomfield recommends replacing the hoses.

Brewer is ready to use.

## TROUBLESHOOTING SUGGESTIONS

SYMPTOM	POSSIBLE CAUSE	SUGGESTED REMEDY
Will not heat or brew (no lights)	Brewer not plugged in or circuit breaker tripped	Reconnect brewer to electric power Reset circuit breaker
	Fuse blown	Check satellite for water saturation Replace fuse
Will not brew	Satellite is not in proper position	Reinstall satellite. Satellite light should be on
	Brew switch damaged	Check. Replace if needed
	Timer damaged	Check. Replace if needed
	Volume selector switch damaged	Check. Replace if needed
	Satellite connector snap-action switch damaged	Check. Replace if needed
Brewer fails to heat	Tank heat switch off	Turn tank heat switch on
	Hi-limit tripped	Allow to cool, reset hi-limit
	Thermostat out of adjustment or damaged	Check. Adjust or replace as needed
	Satellite receptacle or brewer connector damaged	Check connectors. Be sure all pins are in place and tight. Replace if needed
Brewer fails to stop brewing after STOP switch pressed	Switch not pressed long enough or firmly enough	Switch must be pressed firmly for at least 1 second
	Stop Brew switch damaged	Check. Replace if needed
	Brew solenoid damaged or dirty	Check. Clean or replace as needed
Coffee overflows from brew chamber	Too much coffee or too fine a grind	Use proper amount and grind of coffee grounds per brew
	More than 1 filter paper or wrong type of filter paper used	Use 1 genuine Bloomfield filter paper per brew
	Timer out of adjustment or damaged	Check time. Adjust or replace as needed
	Brew solenoid damaged	Check. Replace if needed
	Wire rack missing from brew chamber	Check. Replace if needed
Insufficient brew volume (all volumes)	Low inlet water pressure	Other appliances on water line may be robbing pressure. Brewer should be on dedicated water line
	Inlet strainer plugged	Clean strainer
	Timers out of adjustment	Adjust time for each brew volume
	Timer damaged	Check. Replace if needed
Satellite overflows (1-1/2 gal brew only)	Bypass solenoid damaged	Check. Replace if needed

## TROUBLESHOOTING SUGGESTIONS (continued)

SYMPTOM	POSSIBLE CAUSE	SUGGESTED REMEDY
Insufficient brew volume (any one volume only)	Timer out of adjustment	Adjust time for each brew volume
	Timer damaged	Check. Replace if needed
	Volume select switch damaged	Check. Replace if needed
Insufficient brew volume (1-1/2 gallon brew only)	Timer out of adjustment	Adjust time for each brew volume
	Bypass solenoid damaged	Check. Replace if needed
	Volume select switch damaged	Check. Replace if needed
Satellite light neither lit nor flashing with satellite in place	Satellite not in proper position	Reinstall satellite.
	Satellite receptacle or brewer connector damaged	Check connectors. Be sure all pins are in place and tight. Replace if needed
	Connector snap-action switch damaged	Check. Replace if needed
Satellite light on with no satellite in place	Connector snap-action switch damaged	Check. Replace if needed
Satellite light flashes constantly	Quality hold time exceeded	Discard coffee, brew fresh Remove satellite for 5 seconds to reset
	Satellite was in place when power was turned on	Remove satellite. Turn brewer off for 5 seconds, turn on then reinstall satellite
	Quality timer damaged	Check. Replace if needed
Ready light does not glow	Light damaged	Check. Replace if needed
Constant drip from brew head	Brew solenoid dirty or damaged	Check. Clean or replace as needed
	Faucet coil leaking.	Check by turning faucet valve off. If leak stops, replace coil
	Thermostat set too high	Set per chart on page 11.
Poor spray pattern from spray disk	Spray disk holes plugged	Check. Clean as needed
	Gasket missing or improperly installed	Reinstall gasket inside brew head
No water from faucet	Low inlet water pressure	Other appliances on water line may be robbing pressure. Brewer should be on dedicated water line
	Faucet valve off	Valve must be on for flow from faucet
Faucet drips	Debris in faucet	Disassemble and clean faucet
	Water pressure too high	Install pressure regulator in incoming water line
Poor coffee quality	Keep brewer and satellites clean. Install a taste and odor filter in water supply, and replace cartridges regularly. Use a quality coffee with a consistent roast. Use proper grind and amount of coffee per brew.	

# MODEL 9311 EXPLODED VIEW

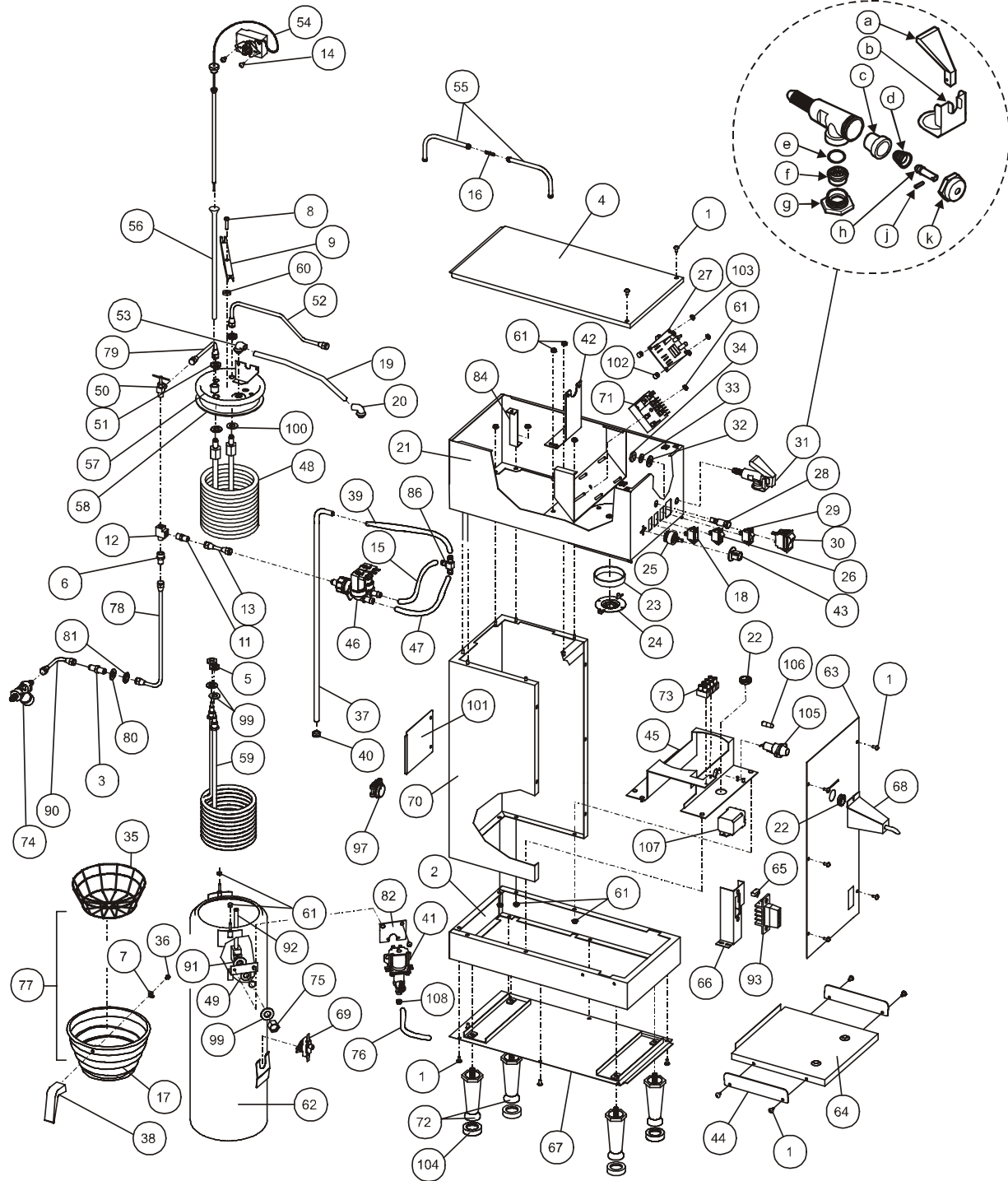

661 74415 9311 Single Satellite Brewer

## MODEL 9311 PARTS LIST

ITEM	SERVICE #	DESCRIPTION	QTY.	ITEM	SERVICE #	DESCRIPTION	QTY.	
1	7200-6X	SCREW PHL SS 8 X 5/16	24	62	82732	TANK WELDED ASSY	1	
2		BASE WELDED ASSY	1	63		PANEL FRONT	1	
3	8812-57	FTG STRAIGHT UNION	1	64		BASE COVER ASSY	1	
4	82491	COVER BASIN	1	65	83105	SWITCH SNAP ACTION	1	
5	8043-28	NUT HEX BR HTG ELEM	2	66		BRACKET CONNECTOR	1	
6	8551-30	FTG_STAIGHT FEMALE TO MALE	1	67		BOTTOM PLATE ASSY	1	
7	8812-73	CLIP WIRE RACK	1	68	82738	SPOUT ASSY	1	
8	8043-47	SCREW HOLD DOWN STRAP	1	69	8552-50	THERMOSTAT HI-LIMIT	1	
9	8043-5	HOLD DOWN STRAP	1	70	82735	BODY WELDED ASSY	1	
10	8543-23	NUT TINNERMAN 8-32	14	71	82736	TIMER-BREW ADJ	1	
11	8706-160	FTG STRAIGHT MALE MALE	1	72	83098	LEG BLACK	4	
12	8812-55	FTG ELBOW	1	73	8552-18	TERMINAL BLOCK	1	
13	80197	TUBE COPPER TO SOLENOID	1	74	SA 9052	STRAINER	1	
14	3-100	SCREW THERMOSTAT	2	75	82739	FTG TANK NUT	1	
15	84405	TUBE SILICONE .312 ID 2.1"	1	76	83537	SILICONE BYPASS TUBE	1	
16	82241	CONNECTOR VENT TUBE	1	77	83100	BREW CHAMBER ASSY	1	
17	83101	CHAMBER BREW	1	78	82514	TUBE COPPER INLET	1	
18	83060	LIGHT, QUALITY	1	79	9102-58	TUBE COPPER TANK INLET	1	
19	82400	TUBE TANK TO SPRAY HEAD	1	80	8551-53	WASHER SS UNION	1	
20	83152	ELBOW SPRAYER	1	81	8710-10	NUT HEX UNION	1	
21		TOP HOUSING WLD ASSY	1	82	83151	BRACKET BYPASS ADAPTOR	1	
22	8543-69	BUSHING HEYCO	1	83	55530	SCREW #8-32 X 3/8	3	
23	8543-42	GASKET SPRAY HEAD	1	84	82589	BRACKET, TANK SUPPORT	1	
24	84132	DISC SPRAYER	1	86	82720	TEE BARB	1	
25	82728	SWITCH ROTARY W/HARNESS	1	90	8540-4	TUBE COPPER 90° BEND	1	
26	83120	SWITCH ROCKER BREW	1	91	8812-70	WASHER BEVELLED	1	
27	83149	TIMER-QUALITY LIGHT (SS1-BDT)	1	92	82741	FTG ELBOW W/EXTENSION	1	
28	8738-2	LIGHT PILOT GREEN	1	93	83046	CONNECTOR WIRED ASSY	1	
29	8812-40	SWITCH NORM ON/OFF	1	97	66385	STRAIN RELIEF	1	
30	82395	SWITCH LTD TANK HTR	1	99	83147	WASHER 1/2 ID	3	
31	82556	FAUCET ASSY	1	100	83148	WASHER 7/16 ID	2	
32	82681	WASHER FAUCET	1	101	8572-34	DOOR ACCESS PLUMBING	1	
33	8551-100B	WASHER TOOTH FAUCET	1	102	83104	SPACER #8	4	
34	82680	NUT FAUCET	1	103	83138	NUT LOCK HEX #8-32	4	
35	8706-9	RACK WIRE CHAMBER	1	104	83107	FEET RUBBER, BLACK	4	
36	8707-3	SCREW BREW CHAMBER	1	105	8875-68	FUSE HOLDER	1	
37	82388	FILL TUBE TANK	1	106	8875-69	FUSE	1	
38	8707-2	HANDLE BREW CHAMBER	1	107	83182	RELAY 30 AMP (SS1-AD55)	1	
39	83537	TUBE SILICONE .312 ID 9"	1	108	83570	INSERT BYPASS REG.	1	
40	82390	GROMMET FILL TUBE	1					
41	82729	VALVE BYPASS	1					
42	84400	BRK SOLENOID	1					
43	82397	KNOB	1					
44	83059	GUIDE BASE COVER	1					
45		BRACKET TANK SUPPORT	1					
46	84404	SOLENOID VALVE ASSY	1					
47	84406	TUBE SILICONE .312 ID 2.5"	1					
48	8540-6	COIL HOT WATER	1					
49	8043-30	GASKET ELEMENT HTG	1					
50	8514-26	VALVE NEEDLE	1					
51	8941-21	NUT BRASS WATER COIL	2					
52	83150	TUBE COPPER TO FAUCET	1					
53	8043-11	ELBOW OUTLET	1					
54	86280	THERMOSTAT	1					
55	8706-20	TUBE VENT LONG	2					
56	87260	TUBE, THERMO WELL 11"	1					
57	82495	TANK COVER	1					
58	8043-12	GASKET TANK COVER	1					
59	8760-44	ELEM HTG 4200W 240V (SS1-BDT)	1					
60	55485	NUT HEX 1/4-20	1					
61	8942-92	NUT KEP 8-32	19					
				<b>ACCESSORIES</b>				
					3902	DRIP TRAY	1	
				<b>FAUCET REPAIR KITS</b>				
					82573	HANDLE (item a)		
					82575	SEAT CUP (item c)		
					82576	FAUCET REPAIR KIT includes HANDLE (a) SEAT CUP (c), SPRING (d), STEM (h), PIN (j) & BONNET(k)		
					82682	RETAINER CLIP (item b)		
					84804	AERATOR REPLACEMENT KIT includes O-RING (e), AERATOR DISK (f) & AERATOR CAP (g)		
					84804	AERATOR REPAIR KIT includes O-RING (e) & AERATOR DISK (f)		

# 9311 WIRING DIAGRAM

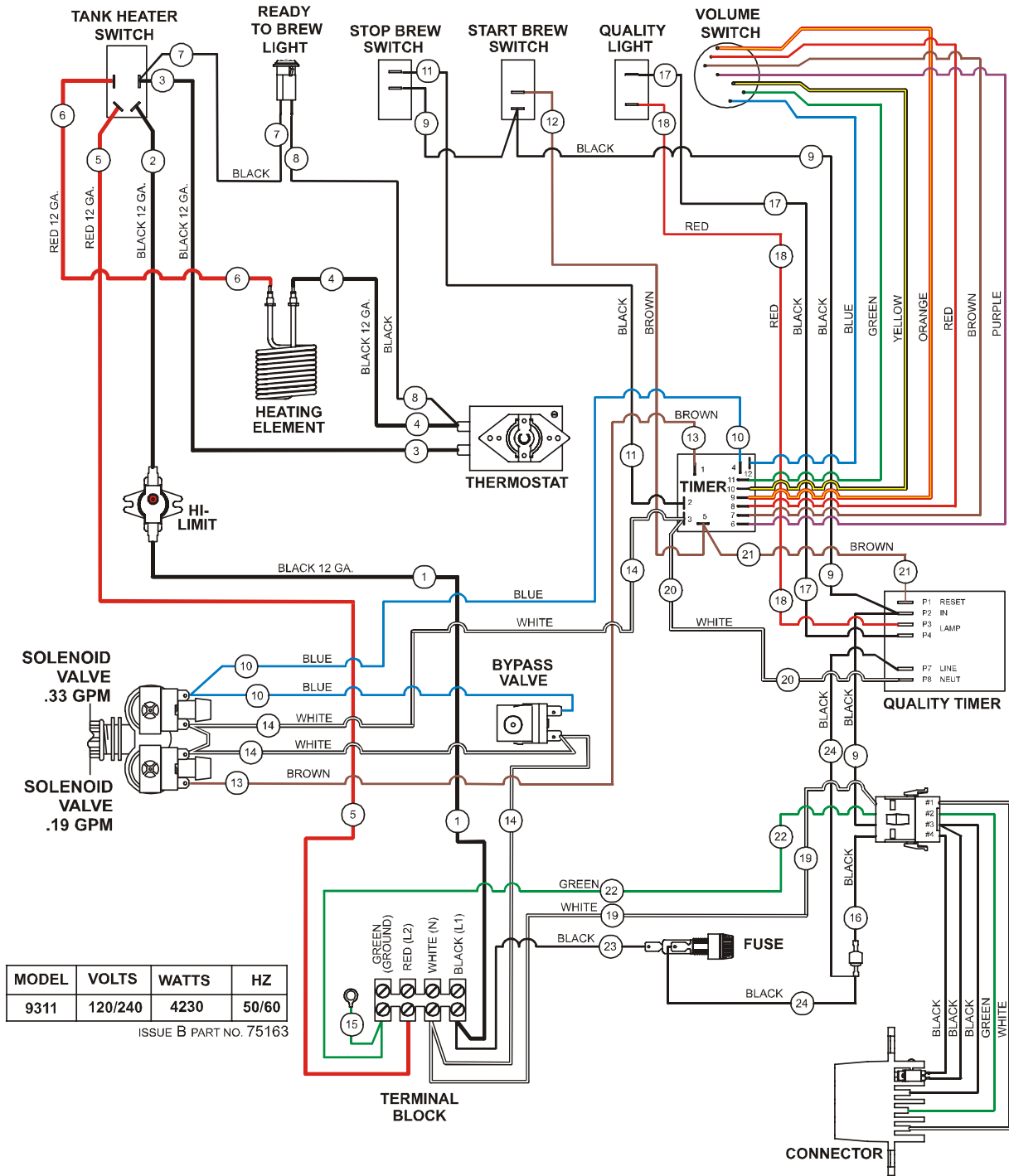

MODEL	VOLTS	WATTS	HZ
9311	120/240	4230	50/60

ISSUE B PART NO. 75163

661 74415 9311 Single Satellite Brewer



# 9340 SATELLITE EXPLODED VIEW & PARTS LIST

## SATELLITE ASSEMBLY 9340 120V

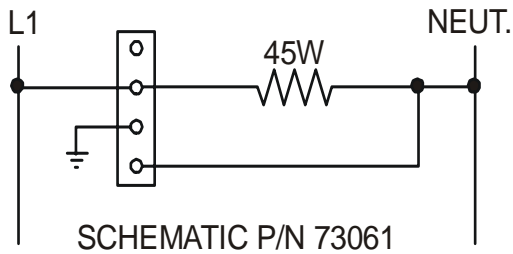
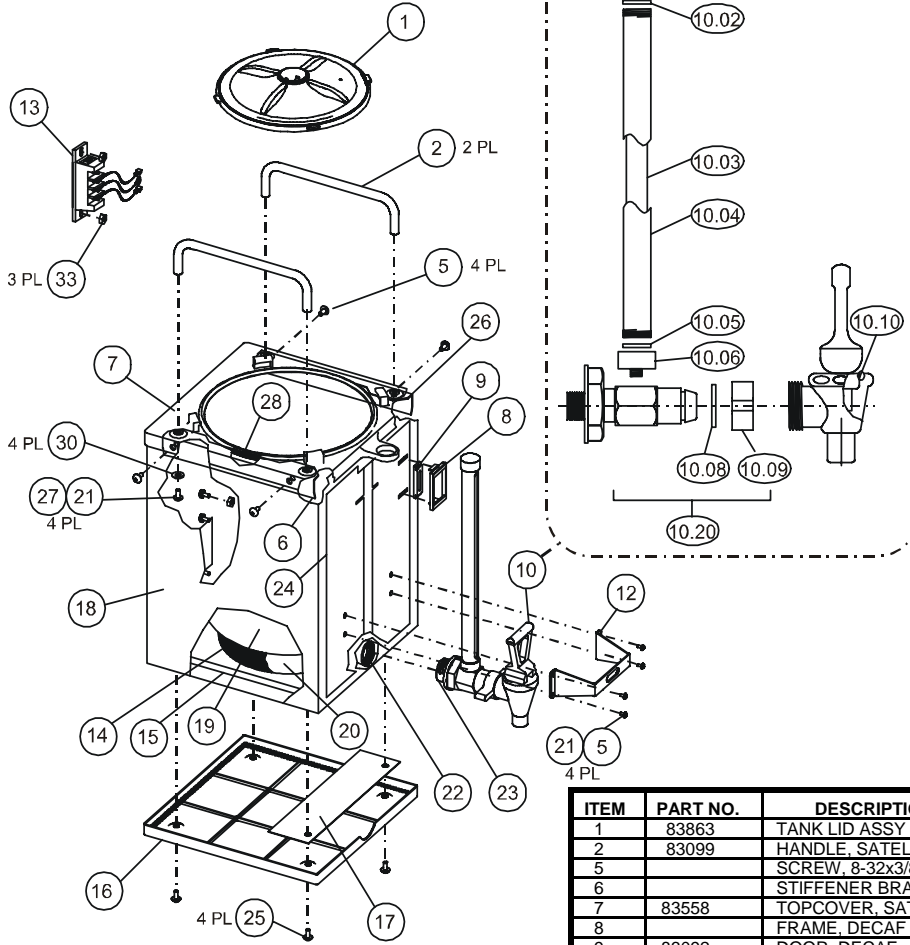

MODEL	VOLTS	WATTS
9340	120	45

ITEM	PART NO.	DESCRIPTION	QTY
1	83863	TANK LID ASSY	1
2	83099	HANDLE, SATELLITE TOP	2
5		SCREW, 8-32x3/8" BLK OXIDE	8
6		STIFFENER BRACKET, LEFT	1
7	83558	TOPCOVER, SATELLITE	1
8		FRAME, DECAF (PART OF #9)	1
9	83092	DOOR, DECAF	1
10	83112	FAUCET w/SIGHT GLASS, 10"	1
10.01	8600-17	SHIELD CAP	1
10.02	8700-25 J	CAP WASHER	1
10.03	8705-11 C	SIGHT GLASS	1
10.04	8600-20	SHIELD ASSY	1
10.05	8705-11 B	BASE WASHER	1
10.06	8705-116	SHIELD BASE	1
10.08	8600-26	C-RING	1
10.09	8600-27	WING NUT	1
10.10	8700-25 L	SEAT CUP	1
10.20	8705-11 D	SHANK ASSY	1
12	84326	HANDLE GUARD, FAUCET	1
13	83172	RECEPTAL, WIRED ASSY	1
14	83114	ELEMENT, HEATER, 45W	1
15	83117	TANK INSULATION	1
16	83057	BASE, POLYPROPYLENE	1
17		PLATE STIFFENER	1
18		WELDMENT, SATELLITE BODY	1
19		TANK SUB ASSY w/FITTINGS	1
20		TAPE, GLASS CLOTH	.33
21		THREADLOCK, RED	A/R
22	8705-26	SEAL, DRAIN FITTING	2
23		TAPE, TEFLON	1.74
24		LABEL, SATELLITE	1
25		SCREW, PAN PHL 8-32x1/2"	4
26		STIFFENER BRACKET, RIGHT	1
27		SCREW, TRS PHL SS 10-32x3/8"	4
28	8705-33	O-RING	1
30		WASHER #10	4
33	8942-92	NUT, KEP SS 8-32	3
34	83132	LABEL, CAUTION "DO NOT IMMERS..."	1

661 74415 9311 Single Satellite Brewer

# CFESA

Commercial Food Equipment Service Association

Bloomfield Industries proudly supports CFESA  
Commercial Food Equipment Service Association

**SERVICE TRAINING - QUALITY SERVICE**



**CUSTOMER SATISFACTION**



**BLOOMFIELD**

**Bloomfield Industries, Inc.**  
**Division of Carrier Commercial Refrigeration**

**In US and Canada**

Telephone: 775-689-5700

Fax: 888-492-2783

Fax: 800-356-5142 (*for orders only*)

website: [www.wellsbloomfield.com](http://www.wellsbloomfield.com)

**PRINTED IN UNITED STATES OF AMERICA**