

Installation Instructions



6 Foot Drill Seed Box Agitator Option

Used with:

- 605NT
- 3P605NT
- 3P600



When you see this symbol, the subsequent instructions and warnings are serious - follow without exception. Your life and the lives of others depend on it!

General Information

These instructions explain how to install the agitator option. The agitator stirs the seed directly above the metering cups. It is intended to cut down on the "bridging" of light fluffy seeds.

These instructions apply to:

118-748A	3P600 Agitator w/Drive - 7-1/2"
118-749A	3P600 Agitator w/o Drive - 7-1/2"
118-750A	3P605NT & 605NT Agitator w/Drive
118-751A	3P605NT & 605NT Agitator w/o Drive
118-788A	3P600 Agitator w/Drive - 6"
118-789A	3P600 Agitator w/o Drive - 6"

Manual Update

Refer to the 6 foot drill operator's manual for detailed information on safely operating, adjusting, troubleshooting and maintaining the agitator option. Refer to the parts manual for part identification.

Drill Manual Part Numbers

151-061M	605NT & 3P605NT Operator's Manual
151-061P	605NT & 3P605NT Parts Manual
118-794M	3P600 Operator's Manual
118-794P	3P600 Parts Manual

Assembly Instructions

Agitator Shaft

See Figure 1:

1. Remove covers (1) from inside both ends of seed box by removing bolt (2), lock washer (3) and hex nut (4).

Before You Start

Beginning on page 8 are detailed listings of parts included in the agitator option packages. Use the proper list to inventory parts received.

Definitions

Right-hand and left-hand as used in this manual are determined by facing the direction the machine will travel while in use unless otherwise stated.

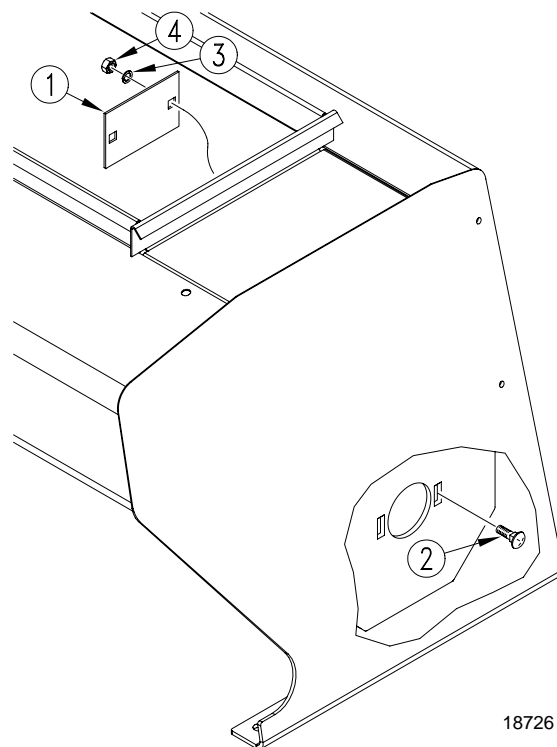

Figure 1
Seed Box Cover Removal

18726

2 | Seed Box Agitator Option

See Figure 2:

2. Slide agitator shaft (5) into seed box from left side of drill.
3. As shaft advances, slide on parts in the following order.
 - 35 tooth sprocket (6)
 - bearing and flanges (7)
 - lock collar (8)
 - bearing and flanges (9)
 - lock collar (10)
 - bearing and flanges (11)
4. Attach bearings and flanges to divider (12) and inside of end panels (13 and 14) with 5/16 x 1 inch round head bolts, lock washers and hex nuts.
5. Slide lock collars (8 and 10) against bearing and flanges (7 and 11) and tighten set screws.

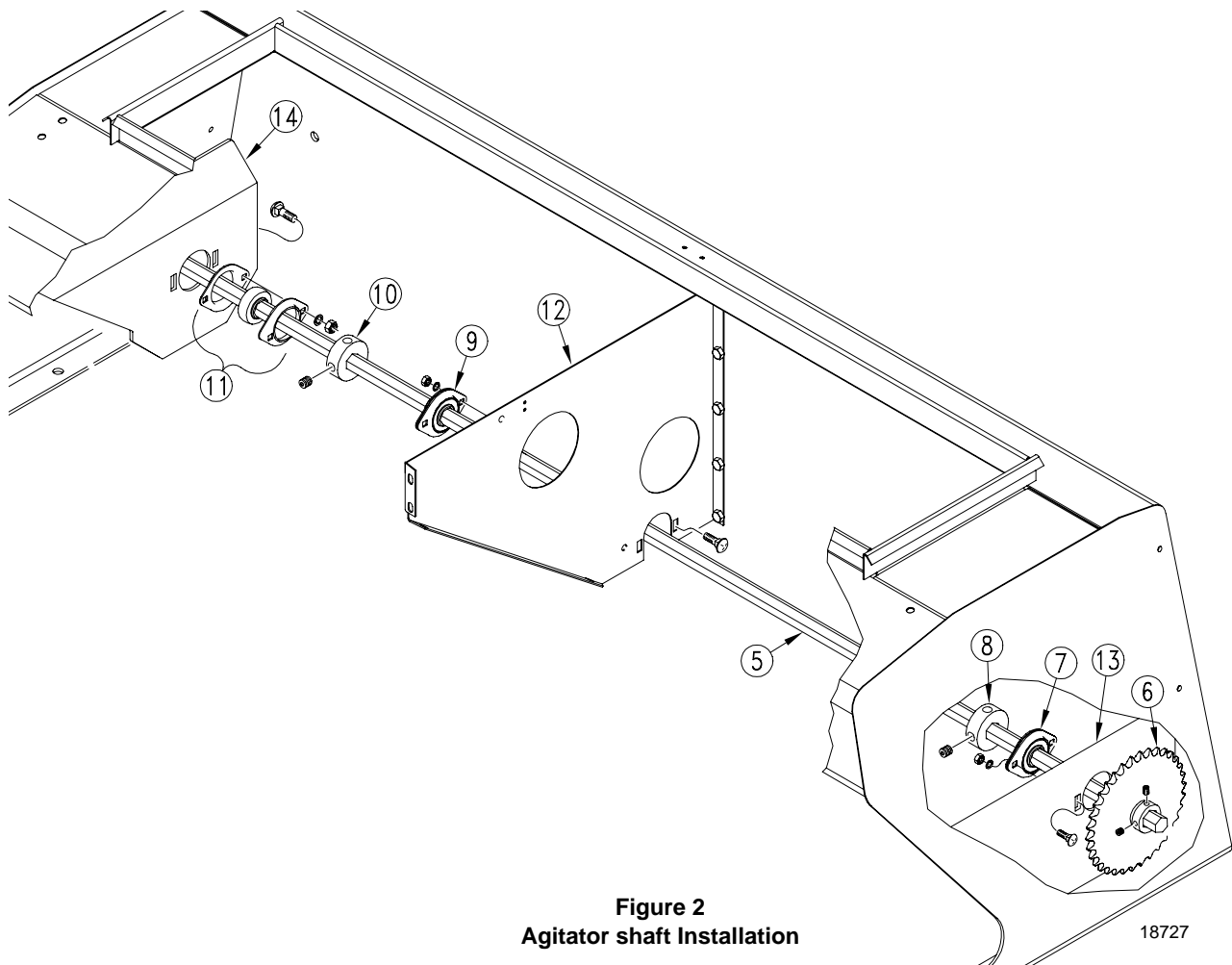

Figure 2
Agitator shaft Installation

18727

Drive Assembly

605NT and 3P605NT Drive

NOTE: If your drill is equipped with a native grass option, a majority of the agitator drive is already installed. Go to page 4 for chain routing.

See Figure 3:

1. Mount bearings and flanges (1) to left side of drill frame and to the frame support as shown. Use 5/16 x 1 inch bolts (2), washers and nuts to secure flanges. Leave bolts loose.
2. Install drive shaft (3) through bearings. As you install shaft, place 17 tooth sprocket (4) on shaft near left side of drill frame.
3. Place 17 tooth sprocket (5) on the right end of shaft.
4. Install three 12 tooth idler sprockets (6) in locations shown, using a 1/2 x 3-1/2 inch bolts (7), hex jam nuts (8), USS flat washers (9) and hex flange nuts (10).

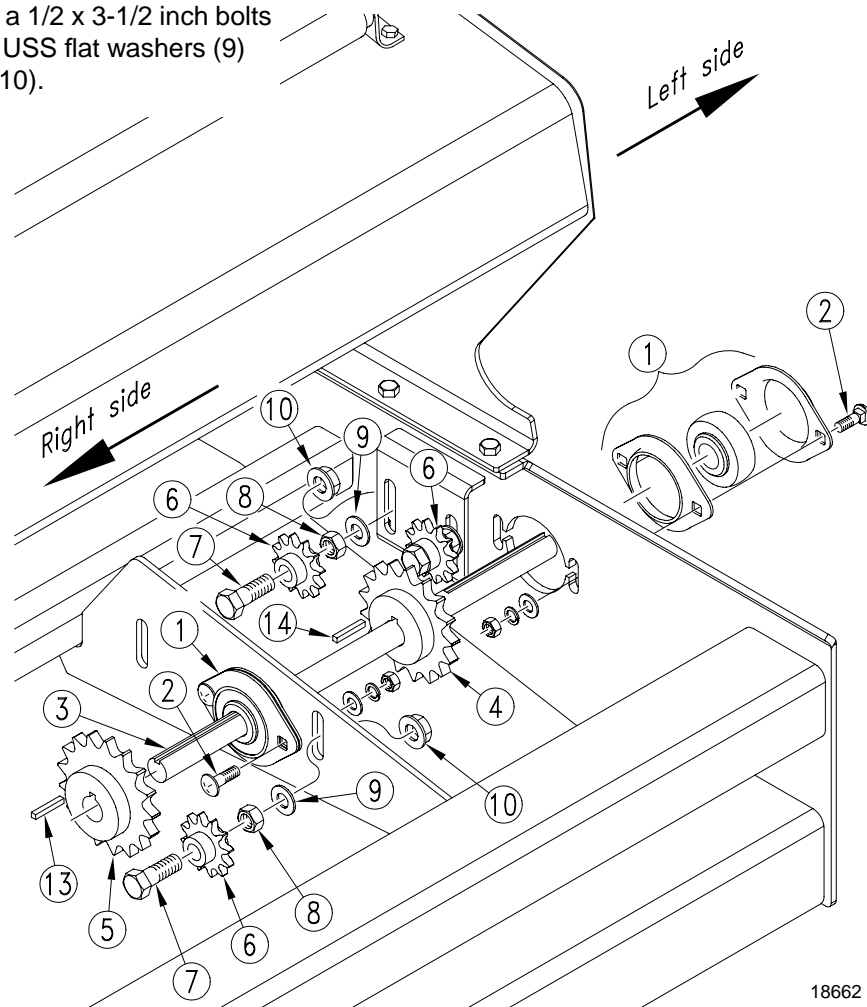

Figure 3
605NT & 3P605NT Drive Assembly

18662

4 | Seed Box Agitator Option

5. Refer to Figure 4. Install 16 tooth splined sprocket (11) to gearbox as shown, and fasten with snap ring (12).

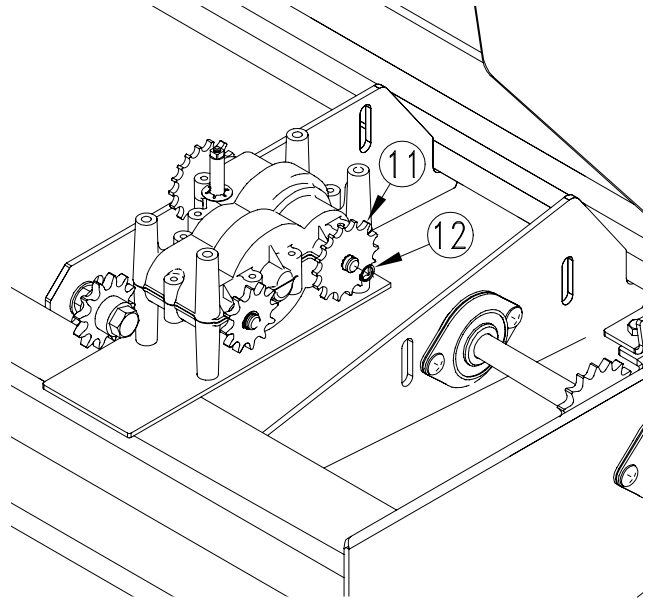
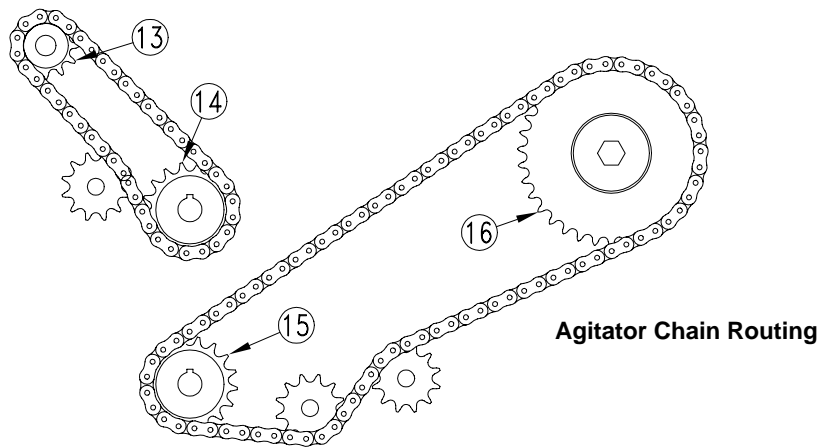

Figure 4
Gearbox Sprocket

18728

See Figure 5:

6. Route chains as follows:
 - a. The 45 pitch chain around new 16 tooth sprocket (13) on gearbox to 17 tooth sprocket (14).
 - b. The 89 pitch chain around 17 tooth sprocket (15) near left side of frame to 35 tooth sprocket (16) on agitator shaft.
7. Adjust idlers to remove chain slack.



Agitator Chain Routing

NOTE: For drills with the native grass option, include the agitator sprocket (16) in the 166 pitch chain routing as shown.

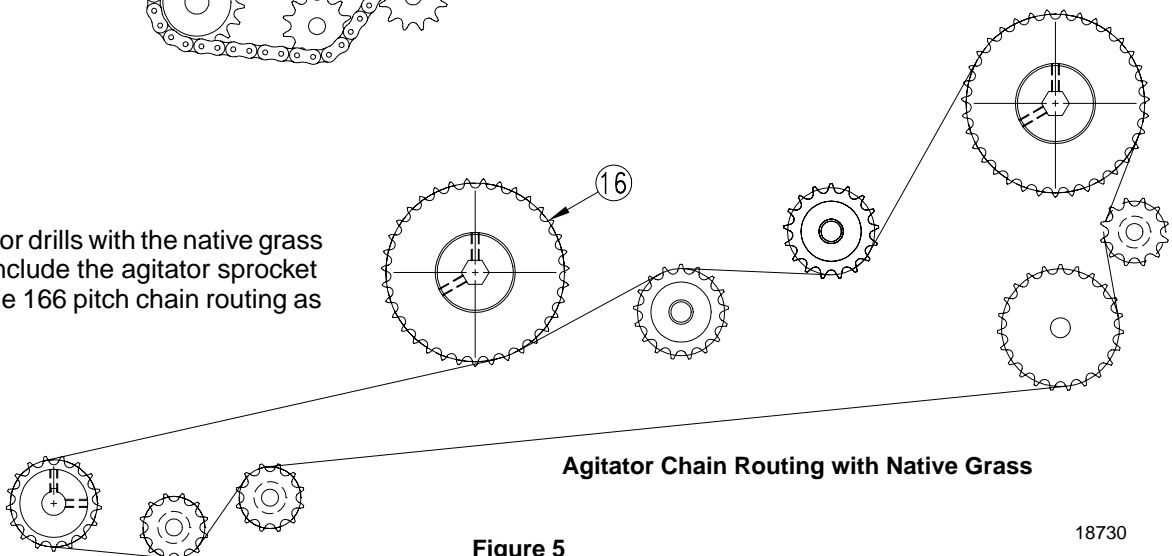

Agitator Chain Routing with Native Grass

Figure 5

18730

3P600 Drive

See Figure 6:

1. Mount bearing and flanges (1) inside end panels of drill frame. Use 5/16 x 1 inch bolts (2), washers and nuts to secure flanges. Leave bolts loose.
2. Install drive shaft (3) through bearings. As you install shaft, place 22 tooth sprocket (4) on shaft to the left of gearbox.
3. Place 17 tooth sprocket (5) on shaft near the left drill frame end panel.
4. Place 12 tooth splined sprocket (6) on left front gearbox shaft. Secure with snap ring (7).
5. Align shaft and tighten flange bolts. Align sprockets (4 and 5). Secure with keys (8 and 9).

3P600 Drive w/Small Seeds Option

If your drill is equipped with a small seeds option, a majority of the agitator drive is already installed.

Refer to Figure 6:

- Place 17 tooth sprocket (5) near left drill frame end panel.
- Align sprocket and secure with key (9).
- Go to step 7b on page 6.

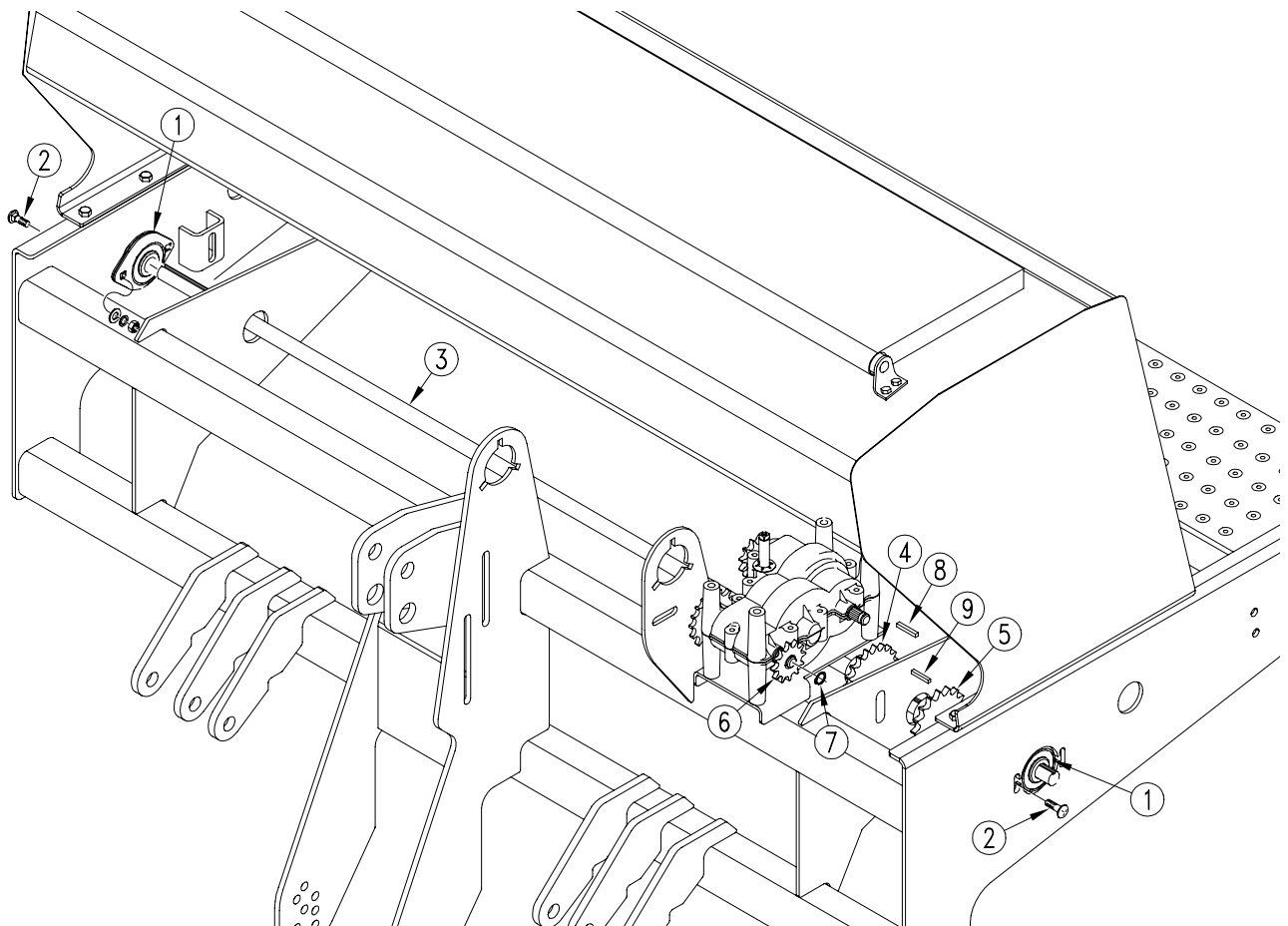

Figure 6
3P600 Drive Assembly

18728

6 | Seed Box Agitator Option

See Figure 7:

6. Install two 12 tooth idler sprockets (10) in locations shown, using 1/2 x 3 1/2 inch bolts (11), hex jam nuts (12), USS flat washers (13) and hex flange nuts (14).

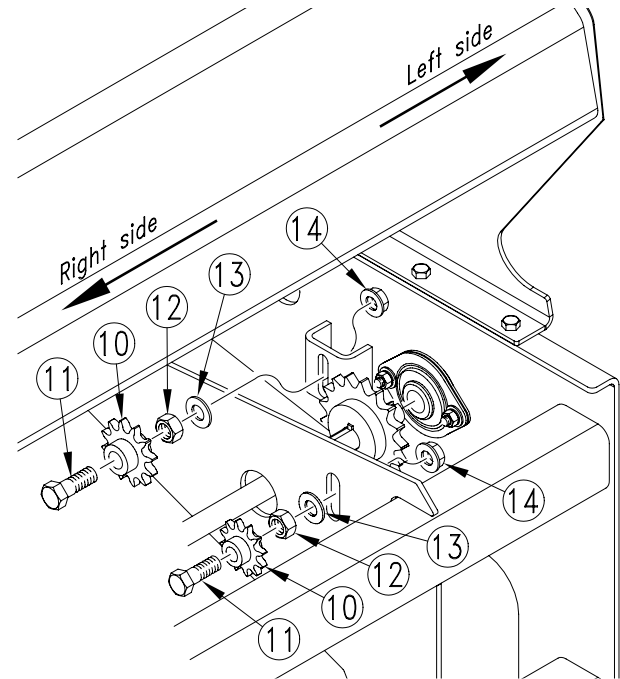

Figure 7
Idler Installation

18731

See Figure 8:

7. Route chains as follows:
 - a. The 63 pitch chain around new 12 tooth sprocket (15) on gearbox to 22 tooth sprocket (16).
 - b. The 68 pitch chain around 17 tooth sprocket (17) near left side of frame to 35 tooth sprocket (18) on agitator shaft.
8. Adjust idlers to remove chain slack.

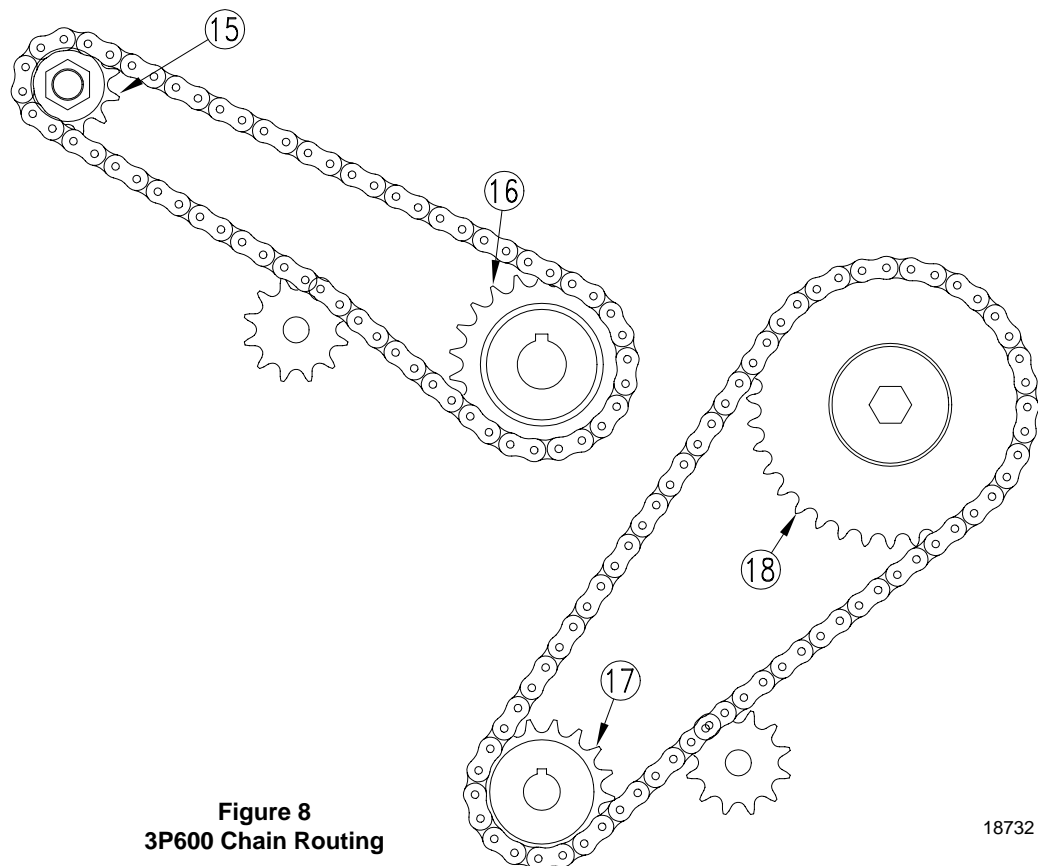

Figure 8
3P600 Chain Routing

18732

Agitator Paddle Installation

See Figure 9:

1. Place an agitator paddle (1) over the hex shaft directly above a feeder cup. Position paddle as shown (paddle 1).
2. Slip a 1/4 x 2 inch hex flange bolt (2) through the paddle and secure with a hex flange lock nut (3).

NOTE: Before tightening a paddle or group of paddles, carefully rotate the drive system to make sure paddles do not hit the tray dividers.

3. Place a paddle over the next feeder cup. Rotate this paddle 1/6th of a turn and slide it onto the next set of flats as shown (paddle 2).
4. Continue the installation above each feeder cup, rotating the paddle 1/6th of a turn each time as shown (paddles 3 through 6).

5. Start over with paddle 1 and continue until each feeder cup has a paddle. The fully assembled shaft will have a spiral result.
6. After checking for interference, torque the paddle bolts to 9 ft. lbs. (108 in lbs.)

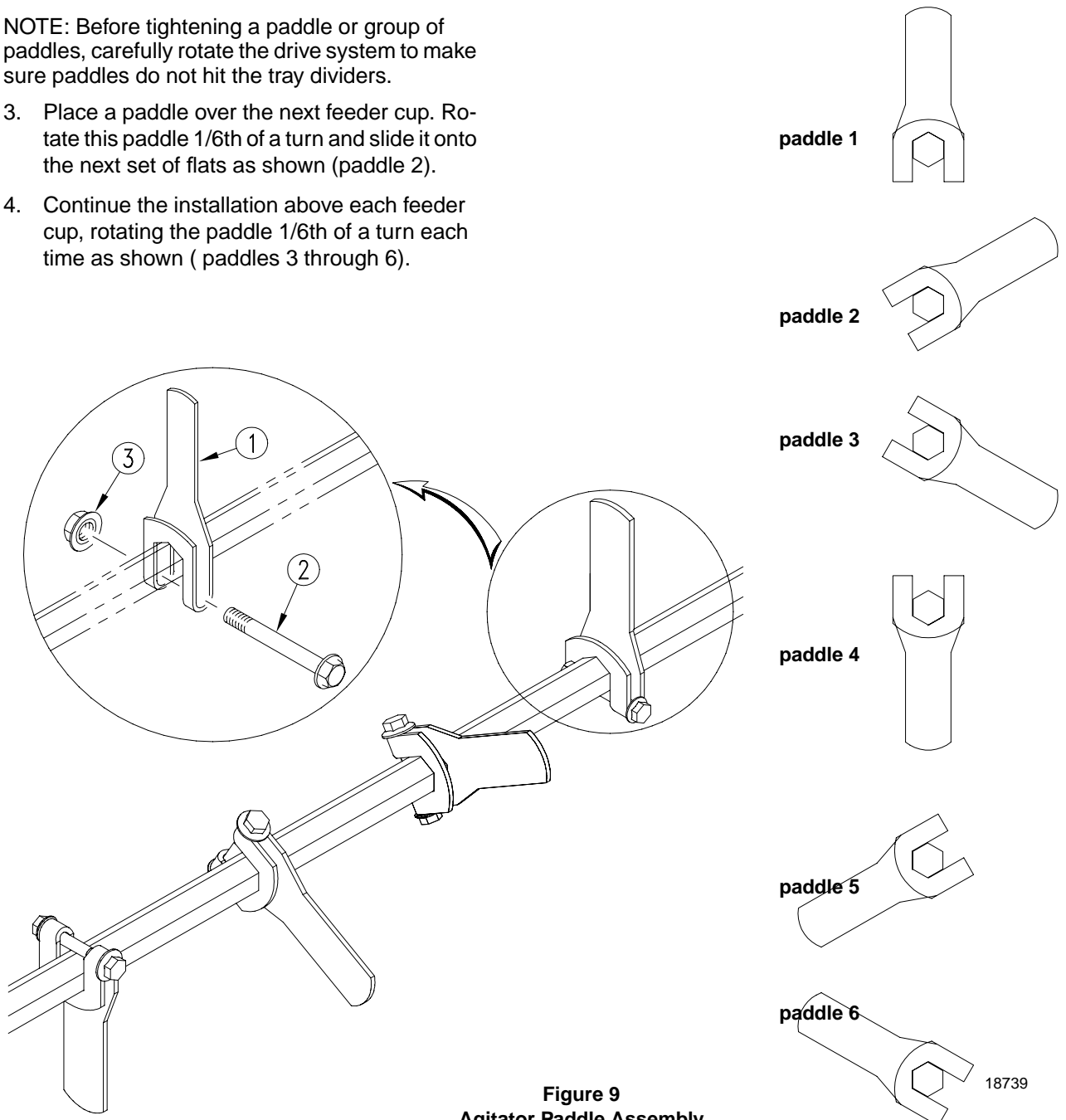

Figure 9
Agitator Paddle Assembly

8 Seed Box Agitator Option

118-748A 3P600 AGITATOR ASSY W/DRIVE - 7-1/2"

Your kit includes:

Qty.	Part No.	Part Description
9	118-493D	AGITATOR PADDLE 3/4 HEX
2	118-494D	LOCK COLLAR 3/4 HEX BORE
1	118-498D	SEED FLOAT DOWN FLOAT STOP
1	118-556D	6' DRILL AGITATOR SHAFT
1	133-037D	SGS/AUXILLARY DRIVE SHAFT
1	136-065D	CHAIN RL #40 63 PITCHES
1	136-111D	CHAIN RL #40 68 PITCHES
2	168-127D	3/16 X 1 KEY
1	800-141C	SNAP RING EXT F/PEERLESS G.B.
4	801-035C	SCREW SET 5/16-18 SKT KP X 3/8
2	802-039C	HHCS 1/2-13X3 GR5
10	802-282C	RHSNB 5/16-18X1 GR5
9	802-448C	HFSS 1/4-20X2 GR5
10	803-008C	NUT HEX 5/16-18 PLT
2	803-036C	NUT HEX JAM 1/2-13PPLT
9	803-088C	NUT HEX LOCK 1/4-20 FLG
2	803-169C	NUT HEX FLG. LOCK 1/2-13 PLT.
10	804-009C	WASHER LOCK SPRING 5/16 PLT
4	804-017C	WASHER FLAT 1/2 USS PLT
1	808-100C	SPROCKET 40B22 3/4B W/K.W. &SS
1	808-160C	SPKT 40B12 X 36T SPLINE BORE
1	808-170C	SPKT 40B17 X 3/4BORE W/KW&SS
1	808-185C	SPKT 40B35 X 3/4 HEX BORE
2	817-025C	NO. 40 12T IDLER SPKT.
2	822-040C	BEARING 3/4BORE 47MM SPHERE OD
10	822-041C	FLANGETTE 47 MST
3	822-128C	BEARING 3/4HEX B 47MM SPHER OD

118-750A 605NT & 3P605NT AGITATOR ASSY W/DRIVE

Your kit includes:

Qty.	Part No.	Part Description
9	118-493D	AGITATOR PADDLE 3/4 HEX
2	118-494D	LOCK COLLAR 3/4 HEX BORE
1	118-498D	SEED FLOAT DOWN FLOAT STOP
1	118-556D	6' DRILL AGITATOR SHAFT
1	202-182D	AUXILLARY DRIVE SHAFT
1	136-054D	CHAIN RL #40 89 PITCHES
1	136-161D	CHAIN RL #40 45 PITCHES
1	168-127D	3/16 X 1 KEY
1	800-141C	SNAP RING EXT F/PEERLESS G.B.
4	801-035C	SCREW SET 5/16-18 SKT KP X 3/8
3	802-039C	HHCS 1/2-13X3 GR5
10	802-282C	RHSNB 5/16-18X1 GR5
9	802-448C	HFSS 1/4-20X2 GR5
10	803-008C	NUT HEX 5/16-18 PLT
3	803-036C	NUT HEX JAM 1/2-13 PLT
9	803-088C	NUT HEX LOCK 1/4-20 FLG
3	803-169C	NUT HEX FLG. LOCK 1/2-13 PLT.
10	804-009C	WASHER LOCK SPRING 5/16 PLT
3	804-017C	WASHER FLAT 1/2 USS PLT
2	808-170C	SPKT 40B17 X 3/4BORE W/KW&SS
1	808-185C	SPKT 40B35 X 3/4 HEX BORE
1	808-271C	SPKT 40B16 X 36T SPLINE BORE
3	817-025C	NO. 40 12T IDLER SPKT.
2	822-040C	BEARING 3/4BORE 47MM SPHERE OD
10	822-041C	FLANGETTE 47 MST
3	822-128C	BEARING 3/4HEX B 47MM SPHER OD

10 Seed Box Agitator Option**118-749A 3P600 AGITATOR ASSY WITHOUT DRIVE - 7-1/2"**

Your kit includes:

Qty.	Part No.	Part Description
9	118-493D	AGITATOR PADDLE 3/4 HEX
2	118-494D	LOCK COLLAR 3/4 HEX BORE
1	118-498D	SEED FLOAT DOWN FLOAT STOP
1	118-556D	6' DRILL AGITATOR SHAFT
1	136-111D	CHAIN RL #40 68 PITCHES
1	168-127D	3/16 X 1 KEY
4	801-035C	SCREW SET 5/16-18 SKT KP X 3/8
1	802-039C	HHCS 1/2-13X3 GR5
6	802-282C	RHSNB 5/16-18X1 GR5
9	802-448C	HFSS 1/4-20X2 GR5
6	803-008C	NUT HEX 5/16-18 PLT
1	803-036C	NUT HEX JAM 1/2-13 PLT
9	803-088C	NUT HEX LOCK 1/4-20 FLG
1	803-169C	NUT HEX FLG. LOCK 1/2-13 PLT.
6	804-009C	WASHER LOCK SPRING 5/16 PLT
2	804-017C	WASHER FLAT 1/2 USS PLT
1	808-170C	SPKT 40B17 X 3/4BORE W/KW&SS
1	808-185C	SPKT 40B35 X 3/4 HEX BORE
1	817-025C	NO. 40 12T IDLER SPKT.
6	822-041C	FLANGETTE 47 MST
3	822-128C	BEARING 3/4HEX B 47MM SPHER OD

118-751A 605NT & 3P605NT AGITATOR ASSY WITHOUT DRIVE

Your kit includes:

Qty.	Part No.	Part Description
9	118-493D	AGITATOR PADDLE 3/4 HEX
2	118-494D	LOCK COLLAR 3/4 HEX BORE
1	118-498D	SEED FLOAT DOWN FLOAT STOP
1	118-556D	6' DRILL AGITATOR SHAFT
1	136-054D	CHAIN RL #40 89 PITCHES
1	168-127D	3/16 X 1 KEY
4	801-035C	SCREW SET 5/16-18 SKT KP X 3/8
2	802-039C	HHCS 1/2-13X3 GR5
6	802-282C	RHSNB 5/16-18X1 GR5
9	802-448C	HFSS 1/4-20X2 GR5
6	803-008C	NUT HEX 5/16-18 PLT
2	803-036C	NUT HEX JAM 1/2-13 PLT
9	803-088C	NUT HEX LOCK 1/4-20 FLG
2	803-169C	NUT HEX FLG. LOCK 1/2-13 PLT.
6	804-009C	WASHER LOCK SPRING 5/16 PLT
2	804-017C	WASHER FLAT 1/2 USS PLT
1	808-170C	SPKT 40B17 X 3/4BORE W/KW&SS
1	808-185C	SPKT 40B35 X 3/4 HEX BORE
2	817-025C	NO. 40 12T IDLER SPKT.
6	822-041C	FLANGETTE 47 MST
3	822-128C	BEARING 3/4HEX B 47MM SPHER OD

118-788A 3P600 AGITATOR ASSY W/DRIVE - 6"

Your kit includes:

Qty.	Part No.	Part Description
11	118-493D	AGITATOR PADDLE 3/4 HEX
2	118-494D	LOCK COLLAR 3/4 HEX BORE
1	118-498D	SEED FLOAT DOWN FLOAT STOP
1	118-556D	6' DRILL ADGITATOR SHAFT
1	133-037D	SGS/AUXILLARY DRIVE SHAFT
1	136-104D	CHAIN RL #40 62 PITCHES
1	136-111D	CHAIN RL #40 68 PITCHES
2	168-127D	3/16 X 1 KEY
1	800-141C	SNAP RING EXT F/PEERLESS G.B.
4	801-035C	SCREW SET 5/16-18 SKT KP X 3/8
2	802-039C	HHCS 1/2-13X3 GR5
10	802-282C	RHSNB 5/16-18X1 GR5
11	802-448C	HFSS 1/4-20X2 GR5
10	803-008C	NUT HEX 5/16-18 PLT
2	803-036C	NUT HEX JAM 1/2-13GPLT
11	803-088C	NUT HEX LOCK 1/4-20 FLG
2	803-169C	NUT HEX FLG. LOCK 1/2-13 PLT.
10	804-009C	WASHER LOCK SPRING 5/16 PLT
4	804-017C	WASHER FLAT 1/2 USS PLT
1	808-100C	SPKT 40B22 3/4B W/K.W. &SS
1	808-160C	SPKT 40B12 X 36T SPLINE BORE
1	808-170C	SPKT 40B17 X 3/4BORE W/KW&SS
1	808-185C	SPKT 40B35 X 3/4 HEX BORE
2	817-025C	NO. 40 12T IDLER SPKT.
2	822-040C	BEARING 3/4BORE 47MM SPHERE
10	822-041C	FLANGETTE 47 MST
3	822-128C	BEARING 3/4HEX B 47MM SPHER OD

12 Seed Box Agitator Option

118-789A 3P600 AGITATOR ASSY WITHOUT DRIVE - 6"

Your kit includes:

Qty.	Part No.	Part Description
11	118-493D	AGITATOR PADDLE 3/4 HEX
2	118-494D	LOCK COLLAR 3/4 HEX BORE
1	118-498D	SEED FLOAT DOWN FLOAT STOP
1	118-556D	6' DRILL AGITATOR SHAFT
1	136-111D	CHAIN RL #40 68 PITCHES
1	168-127D	3/16 X 1 KEY
4	801-035C	SCREW SET 5/16-18 SKT KP X 3/8
1	802-039C	HHCS 1/2-13X3 GR5
6	802-282C	RHSNB 5/16-18X1 GR5
11	802-448C	HFSS 1/4-20X2 GR5
6	803-008C	NUT HEX 5/16-18 PLT
1	803-036C	NUT HEX JAM 1/2-13 PLT
11	803-088C	NUT HEX LOCK 1/4-20 FLG
1	803-169C	NUT HEX FLG. LOCK 1/2-13 PLT.
6	804-009C	WASHER LOCK SPRING 5/16 PLT
2	804-017C	WASHER FLAT 1/2 USS PLT
1	808-170C	SPKT 40B17 X 3/4BORE W/KW&SS
1	808-185C	SPKT 40B35 X 3/4 HEX BORE
1	817-025C	NO. 40 12T IDLER SPKT.
6	822-041C	FLANGETTE 47 MST
3	822-128C	BEARING 3/4HEX B 47MM SPHER OD