

---

PARABODY INC.

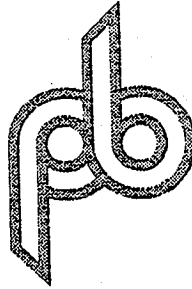

EX500 BASE UNIT  
PBF501

---

**PRODUCT ASSEMBLY  
INSTRUCTION SHEETS**

**TOOLS REQUIRED FOR ASSEMBLY:**

- 9/16 INCH SOCKET
- 3/4 INCH SOCKET
- ADJUSTABLE WRENCH
- HAMMER or RUBBER MALLET
- 3/16 ALLEN WRENCH
- 5/32 ALLEN WRENCH

REVISION: W

If you experience any problems with the assembly of this product, please contact your dealer or your PARABODY Customer Service representative at:

1-800-328-9714.

## PBF501 EX500 BASE UNIT ASSEMBLY INSTRUCTIONS (STEP #1)

---

### IMPORTANT:

- THE INSTRUCTIONS FOR STEP #1 ARE TO BE USED WITH DRAWING SHEET #1 OF 6.
- THE PARABODY EX500 BASE UNIT MUST BE ASSEMBLED ON A FLAT LEVEL SURFACE TO ASSURE ITS PROPER FUNCTION.
- PARABODY INC. STRONGLY RECOMMENDS THAT THIS PRODUCT BE ASSEMBLED BY TWO PERSONS TO AVOID POSSIBLE INJURY

---

**\*\*\* IMPORTANT \*\*\***

**KEEP ALL LOOSE FRAME  
CONNECTIONS  
LOOSE UNTIL INSTRUCTED IN THE  
ASSEMBLY STEP SEQUENCES TO  
SECURELY TIGHTEN**

---

1. Insert four (4) 2 IN. SQ. END CAPS into the ends of the WEIGHT STACK SUPPORT BASE. Also insert one (1) 1-1/2 x 2-1/2 END CAP into the SWIVEL PULLEY MOUNT EXTENSION on the WEIGHT STACK SUPPORT BASE.
2. LOOSELY assemble one (1) 3/8 DIA. x 1 IN. LG. BUSHING PULLEY into the SWIVEL PULLEY MOUNT using one (1) 3/8 x 2 BOLT, one (1) 3/8 LOCK WASHER, and one (1) 3/8 NUT (SEE DETAIL "A"). Insert two (2) 1/2 x 3/4 LG. FLANGE BEARINGS into the SWIVEL PULLEY MOUNT from the bottom and top.
3. Assemble the SWIVEL PULLEY MOUNT to the WEIGHT STACK SUPPORT BASE using one (1) 1/2 x 4-1/2 BOLT, one (1) 1/2 WASHER, and one (1) 1/2 LOW HEIGHT LOCK NUT (SEE DETAIL "A"). Tighten connection so that it swivels smoothly and freely. Place the WEIGHT STACK SUPPORT BASE flat on the floor.
4. Insert four (4) 2 IN. SQ. END CAPS into the ends of the TOP BOOM SECTION. Carefully place the TOP BOOM SECTION on its side on the floor.
5. Carefully place the MAIN BACK SUPPORT on its side on the floor and loosely assemble the MAIN BACK SUPPORT to the TOP BOOM SECTION, using two (2) 1/2 x 7 BOLTS, four (4) 1/2 WASHERS, two (2) 1/2 LOCK WASHERS, and two (2) 1/2 NUTS.

## PBF501 EX500 BASE UNIT ASSEMBLY INSTRUCTIONS (STEP #3)

---

- THE INSTRUCTIONS FOR STEP #3 ARE TO BE USED WITH DRAWING SHEET #4 OF 6.
  - 1. Place each of the two (2) WEIGHT STACK BUMPERS over the GUIDE ROD HOLES (RADIUS EDGES FACING UP) on the WEIGHT STACK SUPPORT BASE. Insert each of the two (2) GUIDE RODS through the WEIGHT STACK BUMPERS and into the WEIGHT STACK SUPPORT BASE. (NOTE: Apply thin film of LUBRICATION (PROVIDED) to guide rods by using paper towel or clean hands.)
  - 2. Press two (2) WEIGHT PLATE BUSHINGS each, into the top of twenty (20) WEIGHT PLATES (40 BUSHINGS total, SEE DETAIL F).
  - 3. USING EXTREME CARE, slide each of the twenty (20) WEIGHT PLATES down over the GUIDE RODS onto the WEIGHT STACK SUPPORT BASE. (BE SURE THE KEY HOLE OF THE WEIGHT PLATES ARE FACING THE FRONT OF THE MACHINE) (SEE DRAWING)
  - 4. Securely assemble the WEIGHT STACK SHAFT into the HEAD PLATE, using one (1) 3/8 X 1-1/2 HEX HEAD BOLT, one (1) 3/8 LOCK WASHER, and one (1) 3/8 WASHER. (SEE DETAIL G)
  - 5. Slide HEAD PLATE ASSEMBLY down over GUIDE RODS onto WEIGHT STACK.
  - 6. Place the WEIGHT SELECT PIN into any WEIGHT PLATE by turning and pushing it to engage the WEIGHT PLATE.
  - 7. Slide two (2) RUBBER O-RINGS and two (2) 13/16 IN. SHAFT COLLARS onto GUIDE RODS. (SEE DETAIL E)
  - 8. Insert the four (4) 3/8 IN. DIA. GUIDE ROD INSULATORS (two per GUIDE ROD) into the GUIDE ROD. Position GUIDE RODS in FRONT of the GUIDE ROD BRACKET on the TOP BOOM SECTION. Attach the GUIDE RODS snugly, using two (2) 3/8 x 1-3/4 BOLTS, four (4) 3/8 WASHERS, two (2) 3/8 LOCK WASHERS, and two (2) 3/8 NUTS (SEE DETAIL "E").
- CAUTION: DO NOT OVER TIGHTEN GUIDE RODS TO THE FRONT SIDE OF THE TOP BOOM SECTION. OVER TIGHTENING MAY CAUSE THE GUIDE RODS TO "ROLL", CREATING A BINDING EFFECT ON THE HEAD PLATE, THUS GIVING POOR HEAD PLATE TRAVEL PERFORMANCE.**
9. Slide 13/16 IN. SHAFT COLLARS and RUBBER O-RINGS up GUIDE RODS, until 4 in. from underside of TOP BOOM SECTION. Tighten ALLEN SCREWS in the COLLARS to secure to GUIDE RODS.
- NOTE: These COLLARS are provided for the purpose of preventing the WEIGHT STACK SHAFT from breaking the TOP PULLEY. Make sure the O-RINGS are placed directly under the COLLARS.**
10. Attach the WEIGHT STACK LABELS (designated from #1 to #20) to the WEIGHT STACK PLATES (SEE DETAIL F)

## PBF501 EX500 BASE UNIT ASSEMBLY INSTRUCTIONS (STEP #1)

---

6. Insert one (1) 2 IN. SQ. END CAP into the BASE SEAT SUPPORT and carefully place it on its side on the floor.
7. Loosely assemble the BASE SEAT SUPPORT to the MAIN BACK SUPPORT, using two (2) 3/8 x 1-1/4 BOLTS, four (4) 3/8 WASHERS, two (2) 3/8 LOCK WASHERS, and two (2) 3/8 NUTS.
8. Insert a 2 IN. SQ. END CAP into the open end of the BASE TEE SECTION.
9. Loosely assemble the BASE TEE SECTION to the MAIN BACK SUPPORT ASSEMBLY (from step #7), at the following two connection points: END CONNECTION: one (1) 1/2 x 5 BOLT, two (2) 1/2 WASHERS, one (1) 1/2 LOCK WASHER, and one (1) 1/2 NUT; and the INSIDE CONNECTION: one (1) 1/2 x 7 BOLT, two (2) 1/2 WASHERS, one (1) 1/2 LOCK WASHER, and one (1) 1/2 NUT.
10. Carefully stand the MAIN BACK SUPPORT ASSEMBLY (from previous step) in its upright position and slide it into position to connect with the WEIGHT STACK SUPPORT BASE. Loosely assemble this connection using, two (2) 1/2 X 3-1/2 BOLTS, four (4) 1/2 WASHERS, two (2) 1/2 LOCK WASHERS, and two (2) 1/2 NUTS.
11. Loosely assemble the REAR LEFT UPRIGHT (NOTE: THIS UPRIGHT HAS FIVE (5) HOLES THROUGH IT) and the REAR RIGHT UPRIGHT to their respective sides at the TOP and BOTTOM CONNECTION POINTS as follows:
  - A. At the TOP CONNECTION POINT, loosely assembling to the TOP BOOM SECTION, use one (1) 1/2 x 7-1/2 BOLT, two (2) 1/2 WASHERS, one (1) 1/2 LOCK WASHER, and one (1) 1/2 NUT on the outside bolt connection. Use one (1) 3/8 X 7-1/2 BOLT, two (2) 3/8 WASHERS, one (1) 3/8 LOCK WASHERS, and one (1) 3/8 NUT on the inside bolt connection. NOTE: ONE (1) 3/8 DIA. x 2 LG. BUSHING PULLEY must be assembled between the tubes on the inside bolt connection (SEE DETAIL "B").
  - B. At the BOTTOM CONNECTION POINT, loosely assembling to the CONNECTOR FLATS on the WEIGHT STACK SUPPORT BASE, use two (2) 1/2 x 3 BOLTS, four (4) 1/2 WASHERS, two (2) 1/2 LOCK WASHERS, and two (2) 1/2 NUTS. BE CAREFUL TO PLACE REAR RIGHT AND LEFT UPRIGHTS ON THE CORRECT SIDES OF THE CONNECTOR FLATS on the WEIGHT STACK SUPPORT BASE.
12. Securely mount the BACK PAD to the MAIN BACK SUPPORT using, two (2) 3/8 x 1-1/4 BOLTS, two (2) 3/8 LOCK WASHERS, and two (2) 3/8 WASHERS. BE SURE TO POSITION THE PAD SO THAT THE METAL HIDEWELT CLIP IS POSITIONED IN THE DOWN POSITION.

PBF501 EX500 ASSEMBLY PARTS LIST FOR STEP #2

COUNT ALL PARTS BEFORE BEGINNING ASSEMBLY

HARDWARE:

ITEM	NAME/DESCRIPTION	QTY
<u>BAG # 2A (PURPLE)</u>		
1.	1/2 X 3-1/2 LG. BOLT .....	2
2.	1/2 X 3 LG. BOLT .....	1
3.	1/2 WASHER .....	4
4.	1/2 LOCK WASHER .....	2
5.	1/2 NUT .....	2
6.	1/2 LOW HEIGHT LOCK NUT .....	1
7.	3/8 WASHER .....	10
8.	5/16 X 1/4 SET SCREW .....	2
9.	2 IN. SQ. END CAP .....	4
10.	7 IN. GRIP .....	2
11.	KNOB .....	3
12.	SPRING .....	3
13.	PLUNGER .....	3
14.	COTTER PIN .....	3
15.	1/2 I.D. X 3/4 LG. FLANGE BEARING .....	2
16.	STAR LOCK COLLAR .....	6
17.	SPACER BUSHING .....	3
18.	BLACK PLASTIC WASHER .....	2
<u>BAG # 2B (YELLOW)</u>		
19.	3/8 X 1-3/4 BOLT .....	1
20.	3/8 X 6-1/2 BOLT .....	5
21.	3/8 X 3-1/4 BOLT .....	2
22.	3/8 X 3 BOLT .....	4
23.	3/8 WASHER .....	10
24.	3/8 LOCK WASHER .....	5
25.	3/8 LOW HEIGHT LOCK NUT .....	7
26.	3/8 NUT .....	3
27.	1-3/4 SQ. END CAP .....	1
28.	1-1/2 SQ. END CAP .....	3
29.	5 IN. GRIP .....	4
30.	PARAGLIDE STRIPS (STRIP OF 8) ....	3
31.	CABLE RETAINING CLIP .....	1
32.	RUBBER BUMPER .....	1
33.	3/4 I.D. X 3/4 LG. FLANGE BEARING .....	2
34.	3/8 THUMBSCREW .....	1
35.	PRESS ARM ADJUSTER .....	1
36.	1/4 X 3/4 BOLT .....	1
37.	1/4 NUT .....	1

# PBF501 EX500 ASSEMBLY PARTS LIST FOR STEP #2

COUNT ALL PARTS BEFORE BEGINNING ASSEMBLY

## WELDMENTS/PARTS:

ITEM	NAME/DESCRIPTION	QTY
1.	ADJUSTABLE PRE STRETCH SLIDE ..... (PB1818-1).....	1
2.	LEG CURL EXTENSION ..... (PB2296-1).....	1
3.	ADJUSTABLE PRE STRETCH SUPPORT ..... (PB2299-1).....	1
4.	ADJUSTABLE SEAT FRAME ..... (PB1809-1).....	1
5.	SEAT HANDLE ..... (PB1830-1).....	2
6.	ROLLER PADS ..... (PB1946-1).....	6
7.	16 IN. ROLLER PAD SHAFT ..... (PB1251-1).....	2
8.	20 IN. ROLLER PAD SHAFT ..... (PB1774-1).....	1
9.	PRESS ARM BEARING SHAFT ..... (PB1808-1).....	1
10.	ADJUSTABLE ROLLER PAD SLEEVE ..... (PB2167-1).....	1
11.	PRESS ARM ..... (PB1801-1).....	1
12.	SEAT PAD ..... (PB1839-1).....	1

NOTE: PLEASE USE THE PULLEY IDENTIFICATION SHEET IN THESE INSTRUCTIONS TO AID IN IDENTIFYING THE CORRECT PULLEYS.

13.	3/8 DIA. x 1 IN. LG. BUSHING PULLEY .....(C1161-1).....	1
14.	3/8 DIA. x 2 IN. LG. BUSHING PULLEY .....(C1161-2).....	7

## PBF501 EX500 BASE UNIT ASSEMBLY INSTRUCTIONS (STEP #2)

---

10. Insert two (2) 2 IN. SQ. END CAP into the TOP and BOTTOM ends of the LEG CURL EXTENSION.
11. Securely assemble the LEG CURL EXTENSION onto the BASE SEAT SUPPORT, using one (1) 1/2 x 3 BOLT, and one (1) 1/2 LOW HEIGHT LOCK NUT.
12. Attach one (1) RUBBER BUMPER to the front of the neck tube of the BASE SEAT SUPPORT approximately where shown, giving sufficient contact.
13. Assemble the two (2) ROLLER PADS to the LEG CURL EXTENSION, using one (1) 16 IN. ROLLER PAD SHAFT, two (2) BLACK PLASTIC WASHERS, and two (2) PUSH-ON COLLARS. NOTE: BE SURE TO INSERT ROLLER PAD SHAFT THROUGH LARGE HOLE ON THE ADJUSTABLE ROLLER PAD SLEEVE. (SEE DETAIL N)
14. Securely assemble the ADJUSTABLE PRE STRETCH SUPPORT to the BASE TEE SECTION, using two (2) 1/2 X 3-1/2 BOLTS, four (4) 1/2 WASHERS, two (2) 1/2 LOCK WASHERS, and two (2) 1/2 NUTS.
15. Slide the ADJUSTABLE PRE STRETCH SLIDE over the ADJUSTABLE PRE STRETCH SUPPORT until the SPRING PIN ASSEMBLY engages the second hole.
16. Assemble one (1) 1/4 X 3/4 BOLT through the top hole on the ADJUSTABLE PRE STRETCH SLIDE and tighten with one (1) 1/4 NUT.
17. Insert one (1) 1-3/4 inch SQ. END CAP into the top end of the ADJUSTABLE PRE STRETCH SUPPORT.
18. Insert one (1) 1-1/2 inch SQ. END CAP into the top end of the SPRING PIN HOUSING of the ADJUSTABLE PRE STRETCH SUPPORT. Repeat this sequence for the SPRING PIN HOUSING of the BASE SEAT SUPPORT, and LEG CURL EXTENSION. (SEE DETAIL C).
19. Assemble the two (2) ROLLER PADS to the MAIN BACK SUPPORT, using one (1) 20 IN. ROLLER PAD SHAFT, and two (2) PUSH-ON COLLARS.
20. Insert two (2) 2 IN. SQ. END CAPS into each end of the ADJUSTABLE SEAT FRAME.
21. Attach the two (2) SEAT HANDLES onto the ADJUSTABLE SEAT FRAME, using two (2) 3/8 x 3-1/4 BOLTS, four (4) 3/8 WASHERS, two (2) 3/8 LOCK WASHERS, and two (2) 3/8 NUTS.
22. Slip two (2) 5 inch GRIPS onto the SEAT HANDLES, NOTE: If a lubricant is required, RUBBING ALCOHOL thoroughly coating the inside of the grip is the best material to use.
23. Assemble the two (2) ROLLER PADS to the ADJUSTABLE SEAT FRAME, using one (1) 16 IN. ROLLER PAD SHAFT, and two (2) PUSH-ON COLLARS.

## PBF501 EX500 BASE UNIT ASSEMBLY INSTRUCTIONS (STEP #2)

---

- THE INSTRUCTIONS FOR STEP #2 ARE TO BE USED WITH DRAWING SHEET #2 & #3 OF 6.
- 1. Securely assemble two (2) 3/8 DIA. x 2 IN. BUSHING PULLEYS into the TOP BOOM SECTION and three (3) 3/8 DIA. x 2 IN. BUSHING PULLEYS into the MAIN BACK SUPPORT, using five (5) 3/8 x 6-1/2 BOLTS, ten (10) 3/8 WASHERS, and five (5) 3/8 LOCK NUTS.
- 2. Attach eight (8) PARAGLIDE STRIPS to the ADJUSTABLE PRE STRETCH SLIDE as shown in (DETAIL C ON SHEET #2 OF 6), using the following steps:
  - A. Thoroughly clean all inside and outside surfaces where the paraglide strips are to be attached.
  - B. Remove the paper backing from the paraglide strips and firmly apply them to all of the shown surfaces (8 Places).
- 3. Loosely assemble one (1) 3/8 DIA. x 1 inch BUSHING PULLEY to the ADJUSTABLE PRE STRETCH SLIDE using one (1) 3/8 x 1-3/4 BOLT, one (1) CABLE RETAINING CLIP, one (1) 3/8 LOCK WASHER and one (1) 3/8 NUT.
- 4. Securely tighten all loose bolt connections made to this point, except for any loose pulley connections.
- 5. Install two (2) 3/4 DIA. FLANGE BEARINGS into the TOP BOOM SECTION and two (2) 1/2 DIA. FLANGE BEARINGS into each side of the neck tube on the BASE SEAT SUPPORT.
- 6. Thread the PRESS ARM ADJUSTER into the adjustment nut on the TOP BOOM SECTION. This can be adjusted later to give the appropriate amount of PRESS ARM pre stretch
- 7. Attach eight (8) PARAGLIDE STRIPS to the outside of the ADJUSTABLE ROLLER PAD SLEEVE as shown in (DETAIL N), using the following steps:
  - A. Thoroughly clean all inside and outside surfaces where the paraglide strips are to be attached.
  - B. Remove the paper backing from the paraglide strips and firmly apply them to all of the shown surfaces (8 Places)
- 8. Assemble the three (3) SPRING PIN ASSEMBLIES at the following places: one (1) for the ADJUSTABLE PRE STRETCH SLIDE, one (1) for the BASE SEAT SUPPORT, and one (1) for the LEG CURL EXTENSION SLIDE, using three (3) PLUNGERS, three (3) KNOBS, three (3) SPRINGS, three (3) SPACERS, and three (3) COTTER PINS, using the following steps:
  - A. Assemble the KNOB to the PLUNGER.
  - B. Insert the PLUNGER through the first hole of the housing.
  - C. Slip the SPRING, and the SPACER over the end of the PLUNGER. (IN THAT ORDER)
  - D. Insert the PLUNGER through the second hole of the housing.
  - E. Pull back SPACER on the PLUNGER, and insert the COTTER PIN through the hole.
  - F. (SEE DETAIL C ON DRAWING)
- 9. Insert the ADJUSTABLE ROLLER PAD SLEEVE into the bottom of the LEG CURL EXTENSION TUBE until the spring pin engages in hole. (SEE DETAIL N)



## PBF501 EX500 BASE UNIT ASSEMBLY INSTRUCTIONS (STEP #2)

---

24. Attach eight (8) PARAGLIDE STRIPS to the ADJUSTABLE SEAT FRAME and the BASE SEAT SUPPORT as shown in DETAIL A and B on the reverse side of the main assembly drawing for STEP #2, (SHEET #3 of 6), using the following steps:
  - A. Thoroughly clean all inside and outside surfaces where the paraglide strips are to be attached.
  - B. Remove the paper backing from the paraglide strips and firmly apply them to all of the shown surfaces (8 Places).
25. Attach the SEAT PAD to the ADJUSTABLE SEAT FRAME, using two (2) 3/8 x 3 BOLTS, two (2) 3/8 LOCK WASHERS, and two (2) 3/8 WASHERS. BE SURE TO POSITION THE PAD SO THAT THE METAL HIDEAWAY WELT CLIP IS FACING INTO THE MAIN BACK SUPPORT.
26. Place the ADJUSTABLE SEAT FRAME ASSEMBLY into the slide receptacle on the BASE SEAT SUPPORT, disengaging the SPRING PIN ASSEMBLY until the plunger engages the first adjustment hole.
27. Install one (1) thumbscrew into the BASE SEAT SUPPORT.
28. Attach the PRESS ARM to the TOP BOOM SECTION, by sliding the PRESS ARM BEARING SHAFT through the PRESS ARM and the TOP BOOM SECTION until it is flush with both sides. Securely tighten two (2) 5/16 SET SCREWS (using a 5/32 inch hex key) through the collars on the PRESS ARM into the PRESS ARM SUPPORT SHAFT. NOTE: POSITION PRESS ARM SO THAT THE EX500 DECAL IS FACING OUT AWAY FROM THE MACHINE.
29. Install the two (2) 3/8 DIA. X 2 IN. BUSHING PULLEYS between the flats on the PRESS ARM, using two (2) 3/8 x 3 BOLTS, four (4) 3/8 WASHERS, two (2) 3/8 LOCK NUTS.
30. Attach two (2) 5 IN. GRIPS and two (2) 7 IN. GRIPS onto the straight and angled PRESS ARM HANDLES, NOTE: If a lubricant is required, RUBBING ALCOHOL thoroughly coating the inside of the grip is the best material to use.

PBF501 EX500 ASSEMBLY PARTS LIST FOR STEP #3

COUNT ALL PARTS BEFORE BEGINNING ASSEMBLY

HARDWARE:

ITEM	NAME/DESCRIPTION	QTY
<u>BAG # 3 (ORANGE)</u>		
1.	WEIGHT STACK BUMPER .....	2
2.	3/8 IN. DIA. GUIDE ROD INSULATOR .....	4
3.	WEIGHT PLATE BUSHINGS .....	40
4.	3/8 X 1-1/2 HEX HEAD BOLT .....	1
5.	3/8 LOCK WASHER .....	3
6.	3/8 WASHER .....	5
7.	3/8 X 1-3/4 BOLT .....	2
8.	3/8 NUT .....	2
9.	WEIGHT SELECT PIN .....	1
10.	13/16 SHAFT COLLARS .....	2
11.	RUBBER O-RING .....	2
12.	LUBRICATION PACKET .....	1

WELDMENTS/PARTS:

ITEM	NAME/DESCRIPTION	QTY
1.	GUIDE ROD ..... (PB2384-1).....	2
2.	WEIGHT PLATE ..... (PB2145-1).....	20
3.	HEAD PLATE ..... (PB2230-1).....	1
4.	WEIGHT STACK SHAFT ..... (PB2845-1).....	1
5.	WEIGHT STACK LABELS (#1 to #20) .....	1

IF GYM HAS 3/4 GUIDE RODS

## PBF501 EX500 ASSEMBLY PARTS LIST FOR STEP #4

COUNT ALL PARTS BEFORE BEGINNING ASSEMBLY

### HARDWARE:

ITEM	NAME/DESCRIPTION	QTY
	<u>BAG # 4 (BROWN)</u>	
1.	5/16 X 1 BOLT .....	1
2.	3/8 X 1-3/4 BOLT .....	2
3.	5/16 WASHER .....	2
4.	5/16 LOCK WASHER .....	1
5.	3/8 LOCK WASHER .....	2
6.	5/16 NUT .....	1
7.	3/8 NUT .....	2
8.	LAT BAR HOOK COVER .....	2
9.	1 IN. DIA. X 8 IN. GRIP .....	4
10.	5/16 IN. SNAP HOOK .....	3
11.	ADJUSTMENT CHAIN, 24 LINK .....	1

### SWIVEL PULLEY HARDWARE/PARTS

ITEM	NAME/DESCRIPTION	QTY
1.	3/8 x 3/4 BOLT .....	1
2.	5/16 WASHER .....	2
3.	3/8 LOW HEIGHT LOCKNUT .....	1
4.	3/8 WASHER .....	1
5.	SWIVEL PULLEY BRACKET ..... (PB2184-1).....	2

### WELDMENTS/PARTS:

ITEM	NAME/DESCRIPTION	QTY
1.	3/8 DIA. x 1 IN. LG. BUSHING PULLEY .....(C1161-1).....	2
2.	PRIMARY CABLE ASSEMBLY ..... (PB2524-1).....	1
3.	SECONDARY CABLE ASSEMBLY ..... (PB2435-1).....	1
4.	LAT BAR ..... (PB2753-1).....	1
5.	LOW ROW-BAR ..... (PBF650).....	1
6.	ANKLE STRAP ..... (PBF900).....	1
7.	TRICEP STRAP ..... (PBF901).....	1
8.	EXERCISE WALL CHART ..... (PB1981-1).....	1

## PBF501 EX500 BASE UNIT ASSEMBLY INSTRUCTIONS (STEP #4)

---

- THE INSTRUCTIONS FOR STEP #4 ARE TO BE USED WITH DRAWING SHEETS #5 & #6 OF 6.

1. Assemble the SWIVEL PULLEY BRACKETS using (1) 3/8 Dia x 3/4 BOLT, (2) 5/16 WASHER, (1) 3/8 WASHER and (1) 3/8 LOCKNUT (TIGHTEN TILL LOCKED THEN BACK NUT OFF 1/4 TURN).
2. Loosely assemble two (2) 3/8 DIA. x 1 IN. LG. BUSHING PULLEYS into the SWIVEL PULLEY BRACKET ASSEMBLY, using two (2) 3/8 x 1-3/4 BOLT, two (2) 3/8 LOCK WASHERS, and two (2) 3/8 NUTS (SEE DETAIL H AND E, SHEET #5).

• NOTE: BEFORE PROCEEDING WITH CABLE INSTALLATION, UNRAVEL CABLE, AND REMOVE AS MUCH SPIRALING AS POSSIBLE.

3. To route the PRIMARY CABLE ASSEMBLY start by inserting the end of the cable with the threaded fitting between the TOP PULLEY and the LAT BAR HOOK. (REMOVE PULLEY FOR EASE OF INSTALLATION) Continue to route cable around the PULLEYS in the configuration shown in the CABLE ROUTING DIAGRAM, SHEET #5).
4. To attach the PRIMARY CABLE to the HEAD PLATE ASSEMBLY, thread the stud into the WEIGHT STACK SHAFT and tighten completely. (SEE DETAIL K)

NOTE: IF THE PEC DEC ATTACHMENT IS TO BE ASSEMBLED AT THIS TIME, SKIP SEQUENCE #4 AND #5 OF THIS PAGE. SAVE ALL THE HARDWARE FROM THESE SEQUENCES TO BE USED WITH THE PEC-DEC. GO TO THE PEC-DEC ATTACHMENT ASSEMBLY INSTRUCTIONS AND COMPLETE STEP #1, AND CONTINUE ON TO STEP #2, (SKIP SEQUENCE #5 ON STEP #2.) THEN RETURN TO STEP #4 (THIS PAGE) OF THE EX500 BASE UNIT AND COMPLETE SEQUENCE #6,#7 AND #8.

5. To route the SECONDARY CABLE ASSEMBLY start by inserting the end of the cable into the front end of the SWIVEL PULLEY MOUNT, and around the PULLEY. (REMOVE PULLEY FOR EASE OF INSTALLATION) Continue to route cable around PULLEYS in the configuration shown in the CABLE ROUTING DIAGRAM, SHEET #5).
6. Attach the end of the SECONDARY CABLE ASSEMBLY (and WITHOUT plastic ball) to the LEG CURL EXTENSION, using one (1) 5/16 x 1 BOLT, two (2) 5/16 WASHERS, one (1) 5/16 LOCK WASHER, and one (1) 5/16 NUT (SEE DETAIL L, SHEET #6).
7. Tighten all remaining loose PULLEY connections.
8. Slip the two (2) ROD END COVERS over the ends of the LAT BAR HOLDER on the TOP BOOM SECTION.
9. Attach four (4) 1 DIA. x 8 LG. GRIPS onto each end of the LAT BAR, and LOW ROW BAR. NOTE: If a lubricant is required, RUBBING ALCOHOL thoroughly coating the inside of the grip is the best material to use.
10. Attach the LAT BAR to the PRIMARY CABLE ASSEMBLY, using one (1) 5/16 SNAP HOOK. Also attach the LOW ROW BAR to the ADJUSTMENT CHAIN on the SECONDARY CABLE ASSEMBLY, using two (2) 5/16 SNAP HOOKS.

**PBF501 EX500 BASE UNIT ASSEMBLY INSTRUCTIONS (STEP #4)**

---

**!!! WARNING !!!**

**MAKE SURE SNAP HOOKS ARE FASTENED BEFORE DOING EXERCISES.**

**!!! WARNING !!!**

**DO NOT OPERATE THIS MACHINE WITH LAT BAR OFF SAFETY HOOKS EXCEPT DURING HIGH PULLEY EXERCISES. ALSO, LAT BAR IS NOT TO BE USED FOR PULL-UPS.**

**!!! ATTENTION USER INSTRUCTION !!!**

**BEFORE DOING ANY EXERCISES, BE SURE THAT THE CABLES ARE TAUT BY: 1) ADJUSTING THE ADJUSTABLE PRE STRETCH SLIDE DOWN THE ADJUSTABLE PRE STRETCH SUPPORT, AND 2) ADJUSTING THE PRESS ARM ADJUSTER SCREW OUT AGAINST THE PRESS ARM. THESE TWO ADJUSTMENTS SHOULD BE MADE AS FAR OUT AS NEEDED IN ORDER TO PROVIDE SUFFICIENT CABLE TIGHTNESS DURING MACHINE USE. 3) IF HEAD PLATE IS NOT SITTING ON TOP OF FIRST WEIGHT STACK PLATE, PLEASE PUSH HEAD PLATE DOWN INSERT WEIGHT PIN TO A DESIRED RESISTANCE AND DO A FEW REPS ON ONE OF THE STATIONS. THIS WILL "SEAT" THE CABLE SYSTEM. 4) REPEAT STEPS 1 AND 2 IF NECESSARY.**

**PLEASE NOTE**

**WE RECOMMEND CLEANING YOUR PRODUCT (PADS AND FRAME) ON A REGULAR BASIS, USING WARM SOAPY WATER. ALSO, TOUCH-UP PAINT CAN BE PURCHASED FROM YOUR PARABODY DEALER, OR FROM YOUR PARABODY CUSTOMER SERVICE REPRESENTATIVE AT:**

**1-800-328-9714**

REVISIONS		
REV	DESCRIPTION	DATE

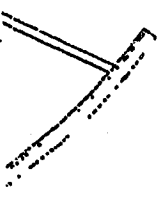

EXTENSION

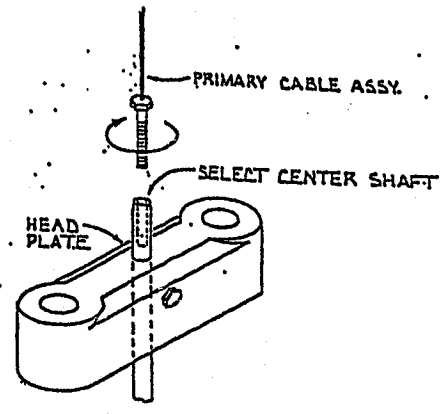

SECONDARY CABLE

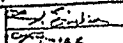
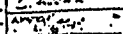

DETAIL "K"

TOLERANCES UNLESS OTHERWISE SPECIFIED DECIMAL FRACTIONAL	 <b>ParaBody, Inc.</b> RAMSEY, MINNESOTA	TITLE <b>EX500 BASE UNIT          ASSY. STEP # 4 CONT</b>	APPROVED 
		DATE _____	CHECKED 
		DRAWN 	DATE _____

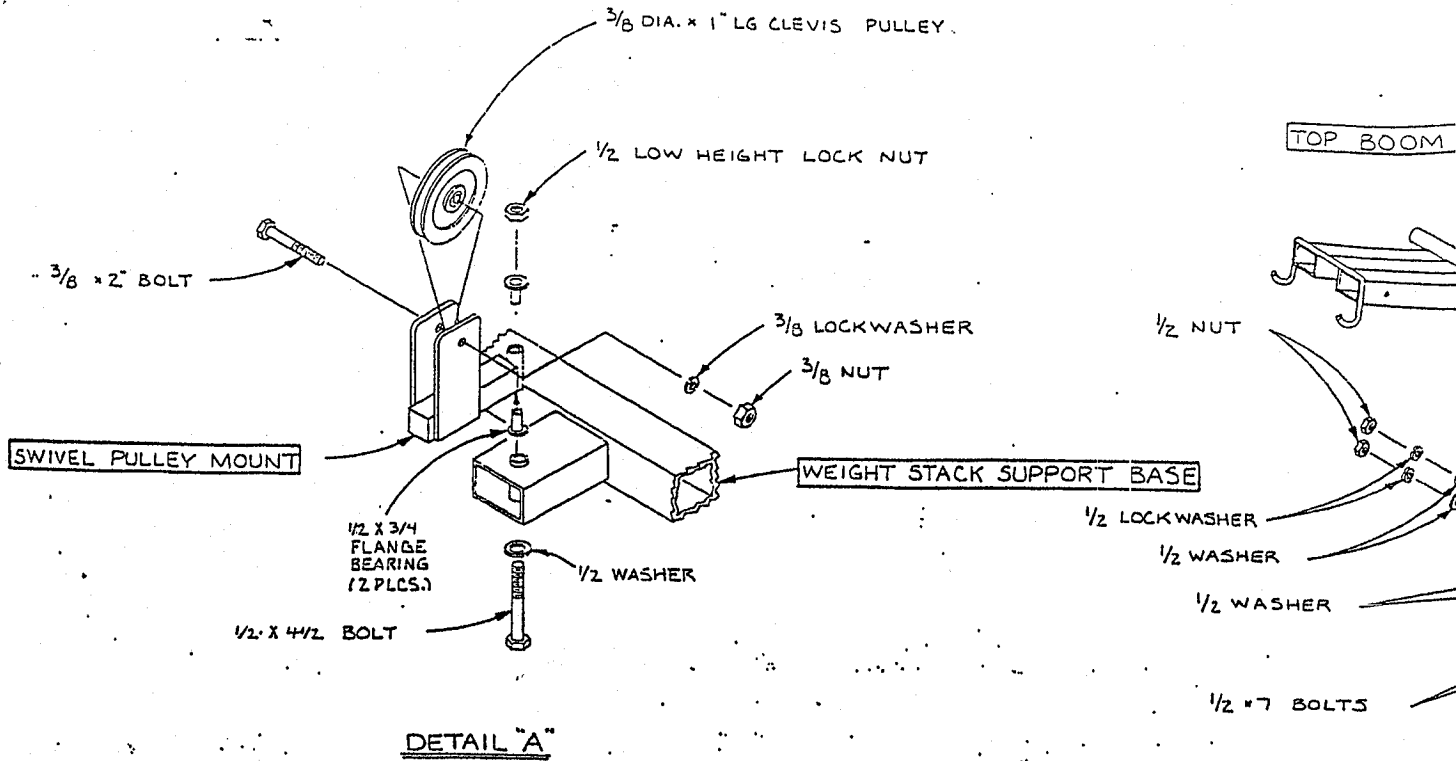

DETAIL "A"

**\*\*\* IMPORTANT \*\*\***  
 KEEP ALL FRAME  
 BOB  
 CONNECTIONS  
 TIGHT UNTIL  
 INSTRUCTED IN  
 THE ASSEMBLY  
 STEP SEQUENCES  
 TO SECURELY  
 TIGHTEN

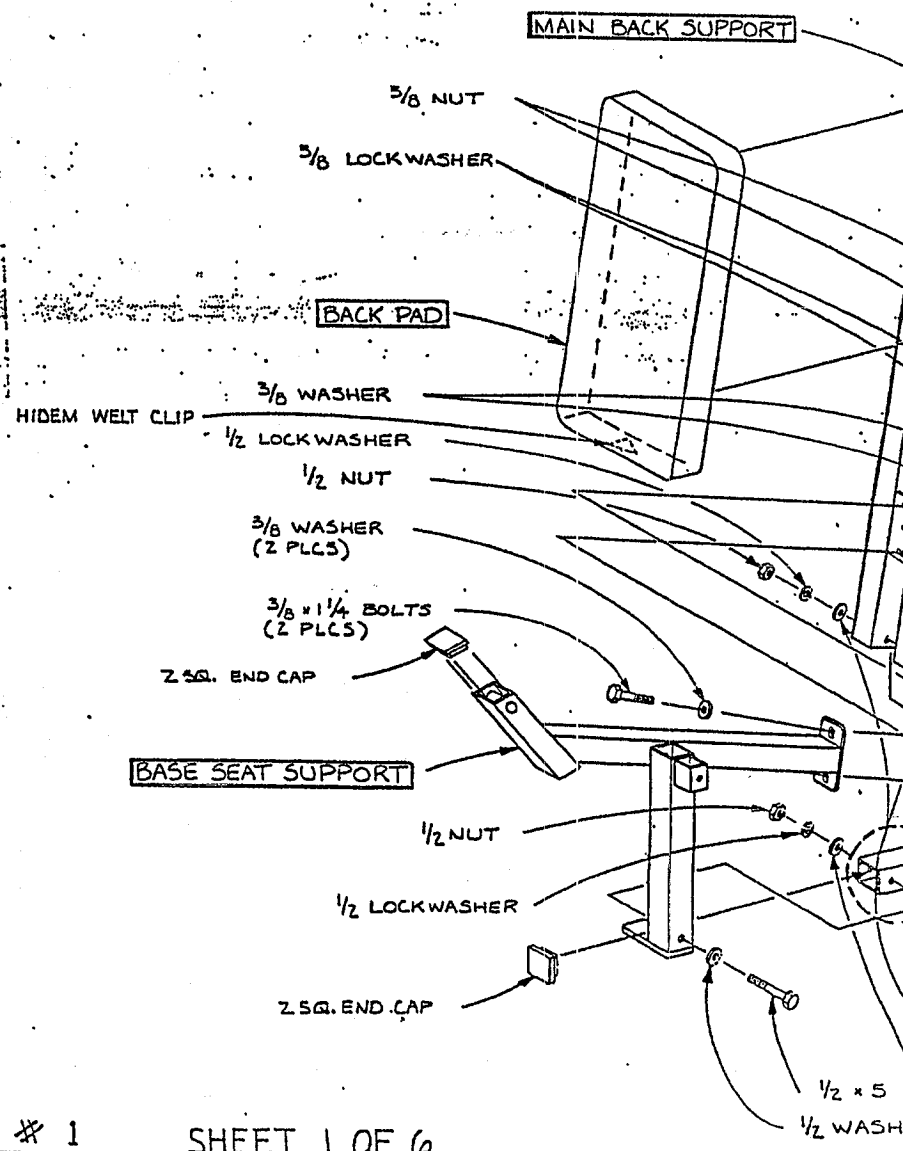

REVISIONS		
REVI	DESCRIPTION	DATE
M	MTPL. CHGS.	1/2/52
N	MTPL. CHGS.	
P	CHG. ADJ. ROLLER P.C. 5	
R	ADD ADJ. ROLLER P.C. 5	
S	ADD U.S.A. LABEL	

SEE DETAIL "B", TO ASSEMBLE TOP BOOM SECTION TO THE LEFT; RIGHT UPRIGHT.

2 SQ. END CAP (TYP 4 PLCS)

REAR LEFT UPRIGHT

THIS PART IS DESIGNATED "LEFT" WITH A SMALL PLASTIC TI-WRAP THROUGH ITS CONNECTOR PLATE.

REAR RIGHT UPRIGHT

PULLEY, 1/2 DIA. X 2" BUSHING

3/8 x 1/4 BOLT

3/8 LOCKWASHER

3/8 WASHER

1/2 x 3 BOLT

1/2 WASHER

1/2 WASHER

1/2 NUT

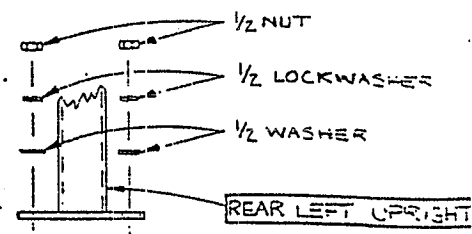

REAR LEFT UPRIGHT

TOP BOOM SECTION

REAR RIGHT UPRIGHT

1/2 WASHER

1/2 x 7/2 BOLT

DETAIL "B"

1/2 NUT

1/2 LOCKWASHER

1/2 WASHER

1/2 x 3 BOLT

1/2 WASHER

1/2 LOCKWASHER

1/2 x 3 1/2 BOLT INSIDE CONNECTION

BASE TEE SECTION

1/2 x 7 BOLT

END CONNECTION

WEIGHT STACK SUPPORT BASE

2 SQ. END CAP (TYP. 4 PLCS)

SWIVEL PULLEY MOUNT EXTENSION

1 1/2 x 2 1/2 END CAP

TOLERANCES UNLESS OTHERWISE SPECIFIED	<p><b>ParaBody, Inc.</b> RAMSEY, MINNESOTA</p>	DATE	BY	CHKD	APP'D
DECIMAL					
FRACTIONAL					
ANGULAR					
SHEET 1 OF 6					
TITLE EX500 BASE UNIT ASSY., STEP #1		DRAWING NO PBF501			
SCALE 1/8" = 1"		SIZE			



SEE SHEET 3 OF 6 FOR PARAGLIDE INSTALLATION INSTRUCTIONS.

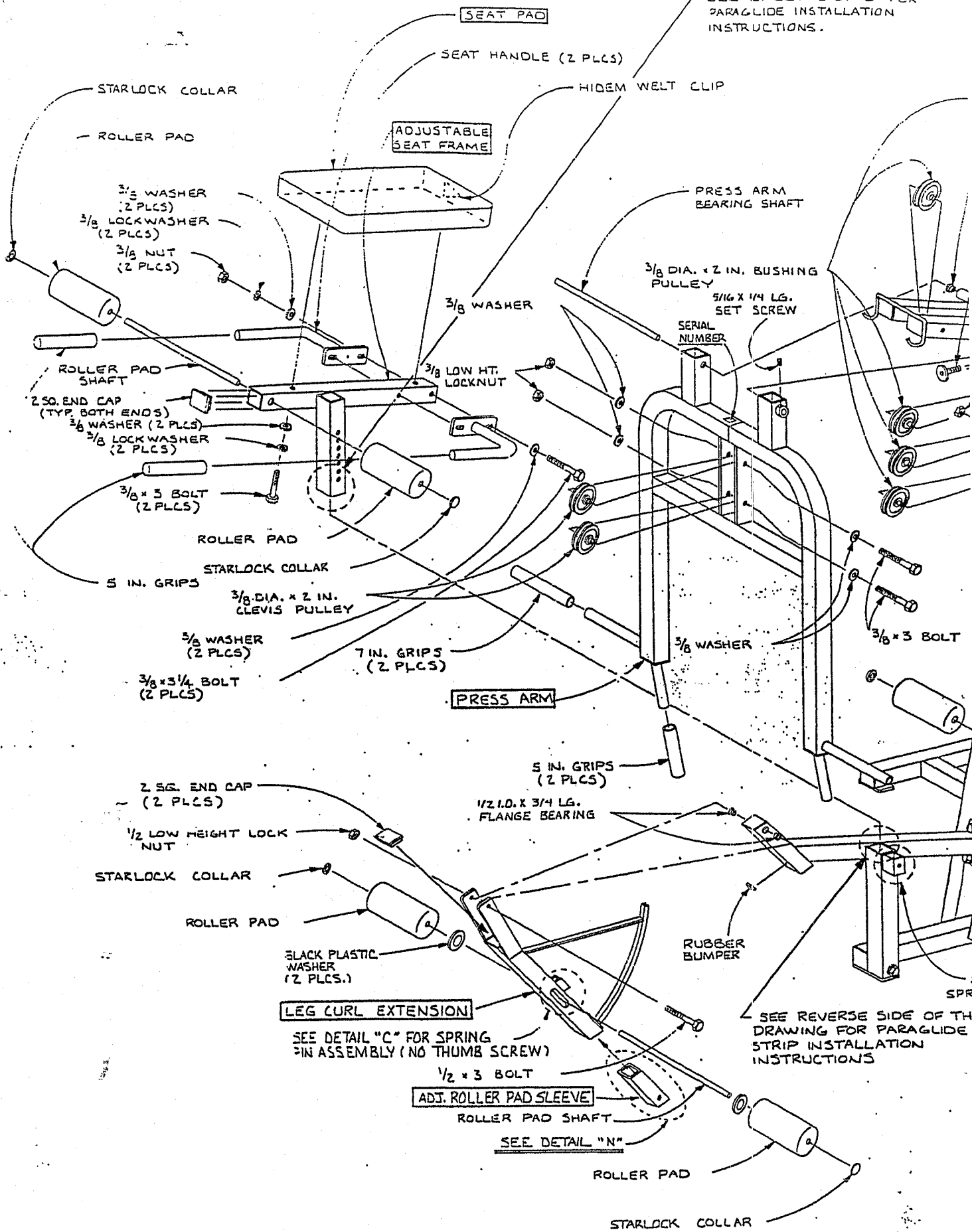

SEE REVERSE SIDE OF THE DRAWING FOR PARAGLIDE STRIP INSTALLATION INSTRUCTIONS

REVISIONS		
REV#	DESCRIPTION	ICNG NO/APP#

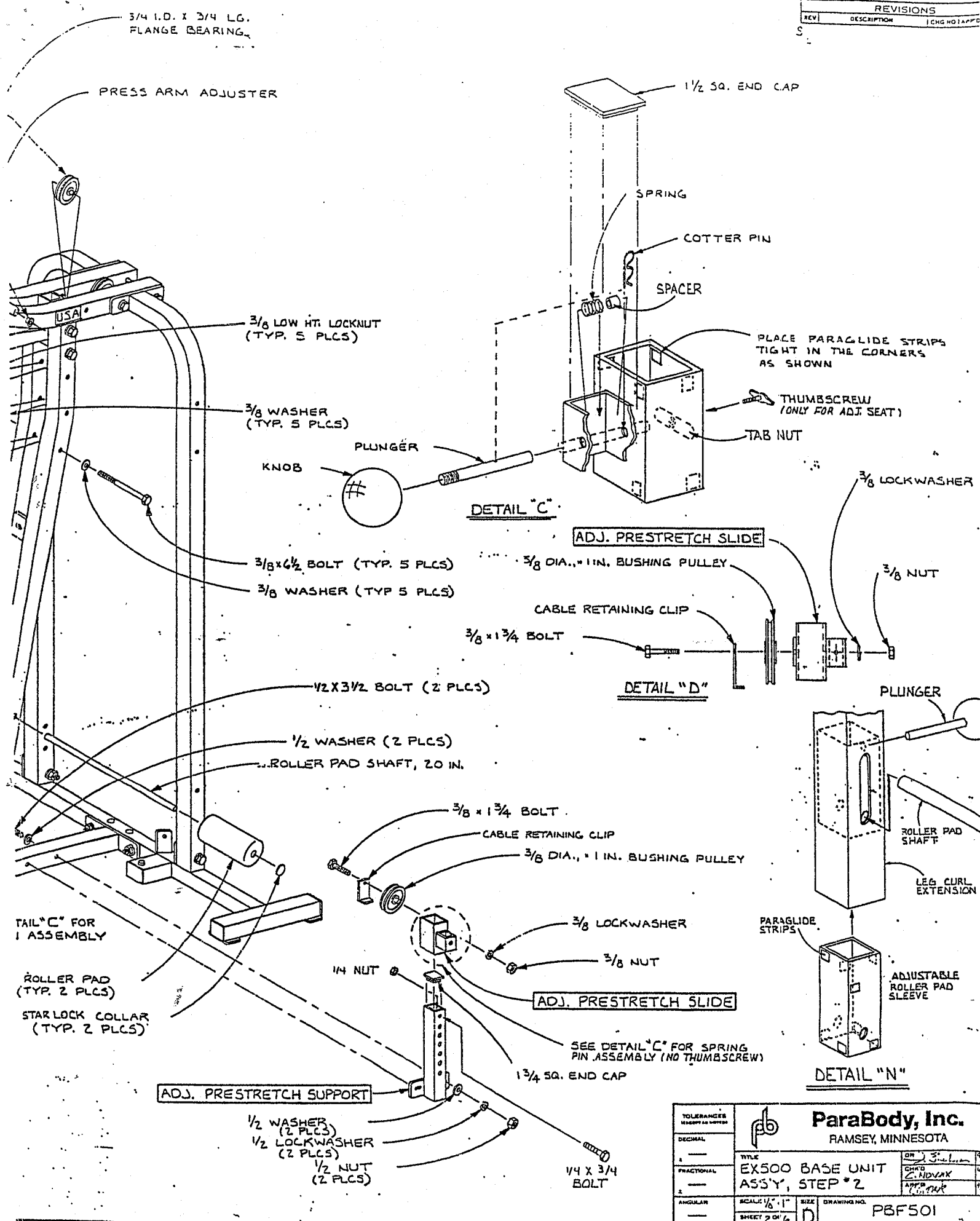

3/4 I.D. X 3/4 LG.  
FLANGE BEARING

PRESS ARM ADJUSTER

1/2 SQ. END CAP

SPRING

COTTER PIN

SPACER

PLACE PARAGLIDE STRIPS  
TIGHT IN THE CORNERS  
AS SHOWN

THUMBSCREW  
(ONLY FOR ADJ. SEAT)

TAB NUT

3/8 LOW HT. LOCKNUT  
(TYP. 5 PLCS)

3/8 WASHER  
(TYP. 5 PLCS)

KNOB

PLUNGER

DETAIL "C"

ADJ. PRESTRETCH SLIDE

3/8 DIA., 1 IN. BUSHING PULLEY

CABLE RETAINING CLIP

3/8 x 1 3/4 BOLT

DETAIL "D"

3/8 LOCKWASHER

3/8 NUT

3/8 x 1/2 BOLT (TYP. 5 PLCS)

3/8 WASHER (TYP. 5 PLCS)

1/2 x 3/2 BOLT (2 PLCS)

1/2 WASHER (2 PLCS)

ROLLER PAD SHAFT, 20 IN.

PLUNGER

ROLLER PAD  
SHAFT

LEG CURL  
EXTENSION

TAIL "C" FOR  
1 ASSEMBLY

ROLLER PAD  
(TYP. 2 PLCS)

STAR LOCK COLLAR  
(TYP. 2 PLCS)

3/8 x 1 3/4 BOLT

CABLE RETAINING CLIP

3/8 DIA., 1 IN. BUSHING PULLEY

3/8 LOCKWASHER

3/8 NUT

ADJ. PRESTRETCH SLIDE

PARAGLIDE  
STRIPS

ADJUSTABLE  
ROLLER PAD  
SLEEVE

SEE DETAIL "C" FOR SPRING  
PIN ASSEMBLY (NO THUMBSCREW)

1 3/4 SQ. END CAP

DETAIL "N"

ADJ. PRESTRETCH SUPPORT

1/2 WASHER  
(2 PLCS)

1/2 LOCKWASHER  
(2 PLCS)

1/2 NUT  
(2 PLCS)

1/4 x 3/4  
BOLT

TOLERANCES UNLESS OTHERWISE SPECIFIED			<b>ParaBody, Inc.</b> RAMSEY, MINNESOTA	
DECIMAL	—		TITLE <b>EX500 BASE UNIT          ASS'Y, STEP # 2</b>	DR. J. J. [Signature] CHD. [Signature] APP. [Signature]
FRACTIONAL	—	SCALE 1/8" = 1"		SIZE D
ANGULAR	—	SHEET 2 of 6	DRAWING NO. PBF501	

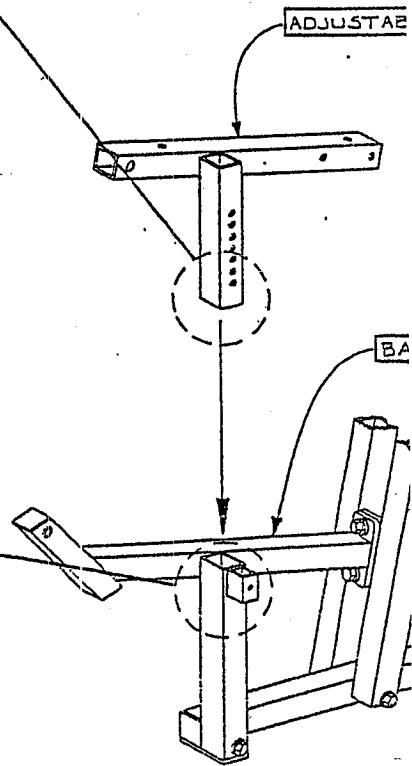
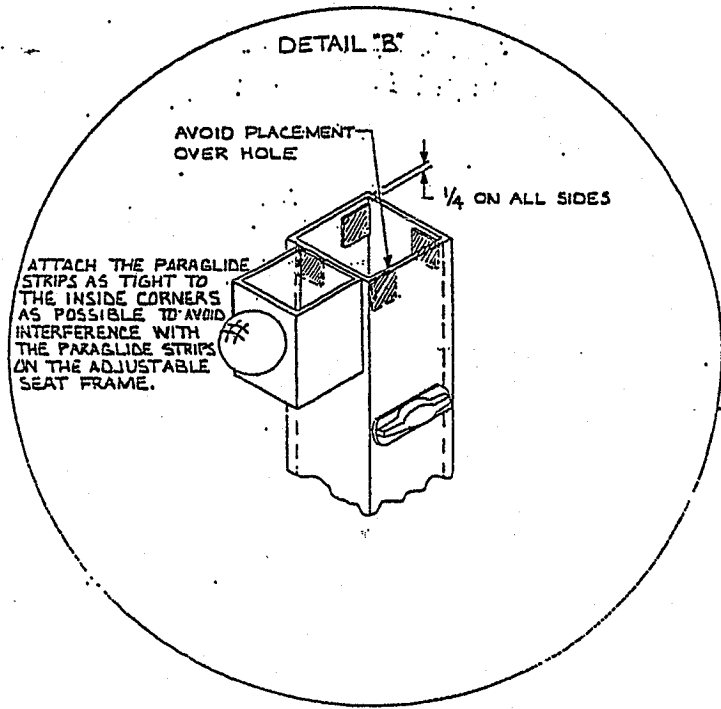
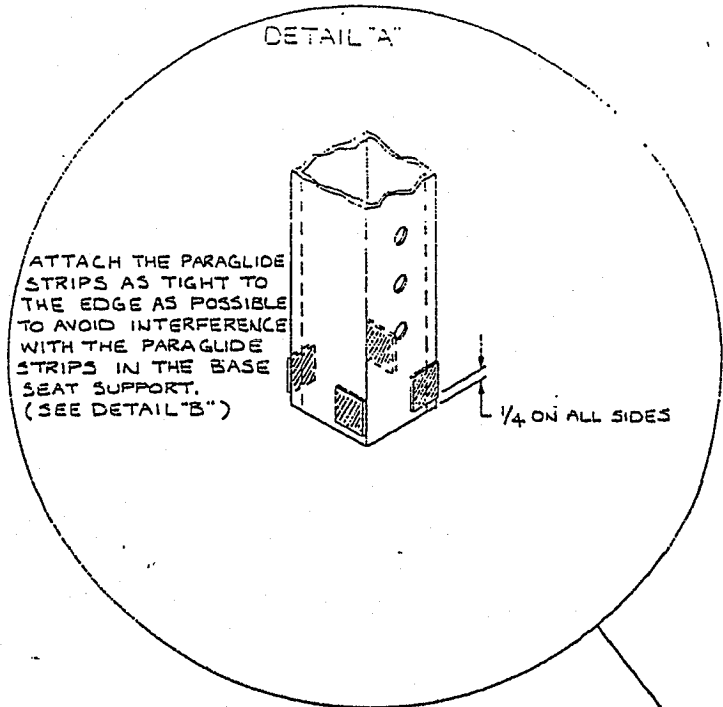

REVISIONS		
REVI	DESCRIPTION	CHG NO / APP
5		

**PARAGLIDE STRIPS INSTALLATION INSTRUCTIONS**

1. Before sliding the ADJUSTABLE SEAT FRAME into the BASE SEAT SUPPORT, you must first attach the paraglide strips to the outside surfaces of the ADJUSTABLE SEAT FRAME, and to the inside surfaces of the BASE SEAT SUPPORT.
2. Thoroughly clean all inside and outside surfaces where the paraglide strips are to be attached.
3. Remove the paper backing from the paraglide strips and firmly apply them to all of the shown surfaces (8 Places).
4. Continue with the rest of the assembly. (ON REVERSE SIDE OF THIS SHEET).

AT FRAME

AT SUPPORT

TOLERANCES UNLESS OTHERWISE SPECIFIED		 <b>ParaBody, Inc.</b> RAMSEY, MINNESOTA	DR. JERICKSON CHG'D C. HAVAR 11/10/71		
DECIMAL	—		TITLE <b>EX500 BASE UNIT          ASS'Y, STEP #2 CONT'D.</b>		
FRACTIONAL	—	SCALE	NONE	SIZE	D
ANGULAR	—	SHEET	3 OF 6	DRAWING NO.	PBF501

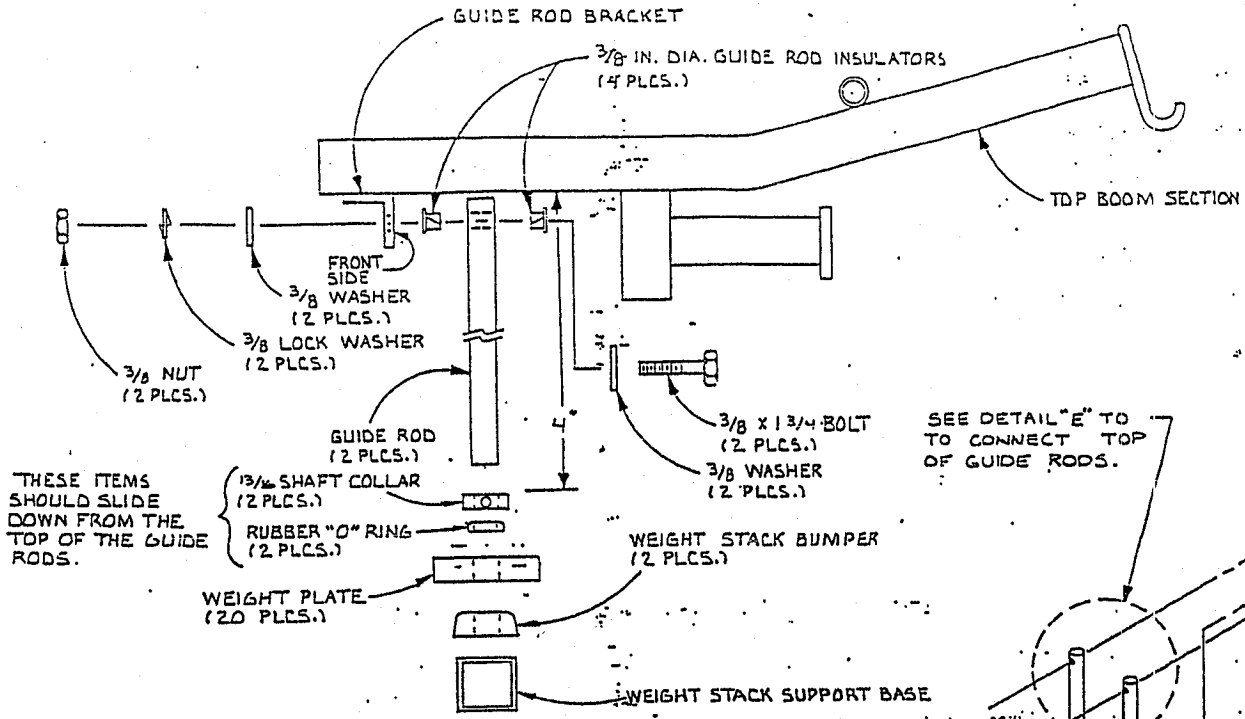

SEE DE  
CONNEC  
GUIDE

THESE ITEMS  
SHOULD SLIDE  
DOWN FROM THE  
TOP OF THE GUIDE  
RODS.

SEE DETAIL "E" TO  
TO CONNECT TOP  
OF GUIDE RODS.

DETAIL "E"

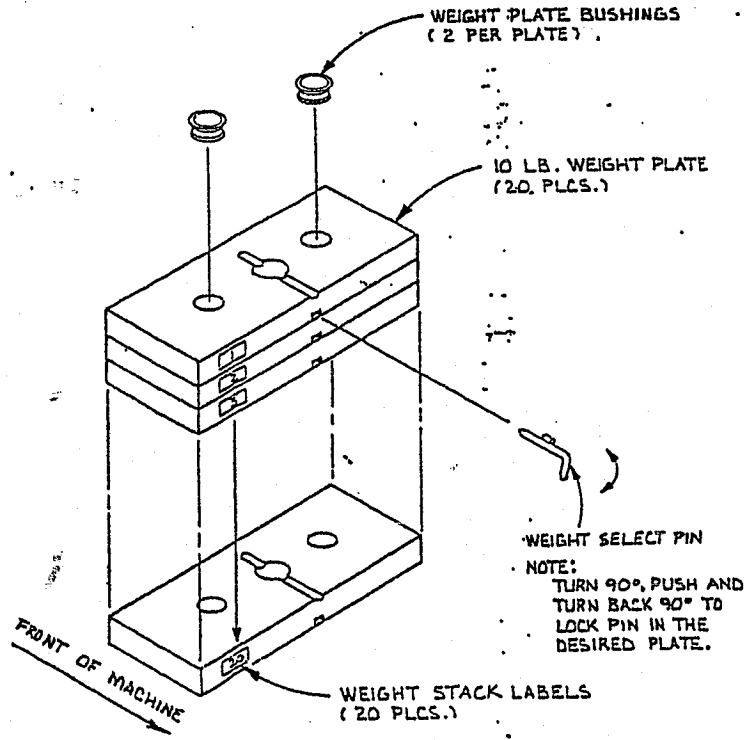

DETAIL "F"

GUIDE RODS

REVISIONS		
REV	DESCRIPTION	ENG NO   APP'D   DATE
5		

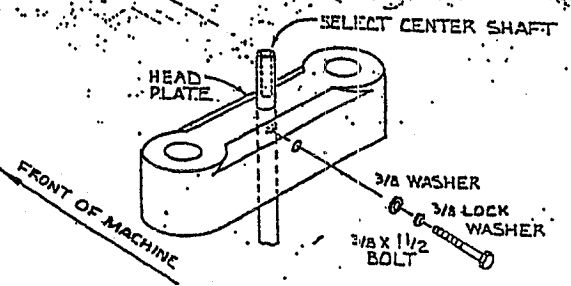
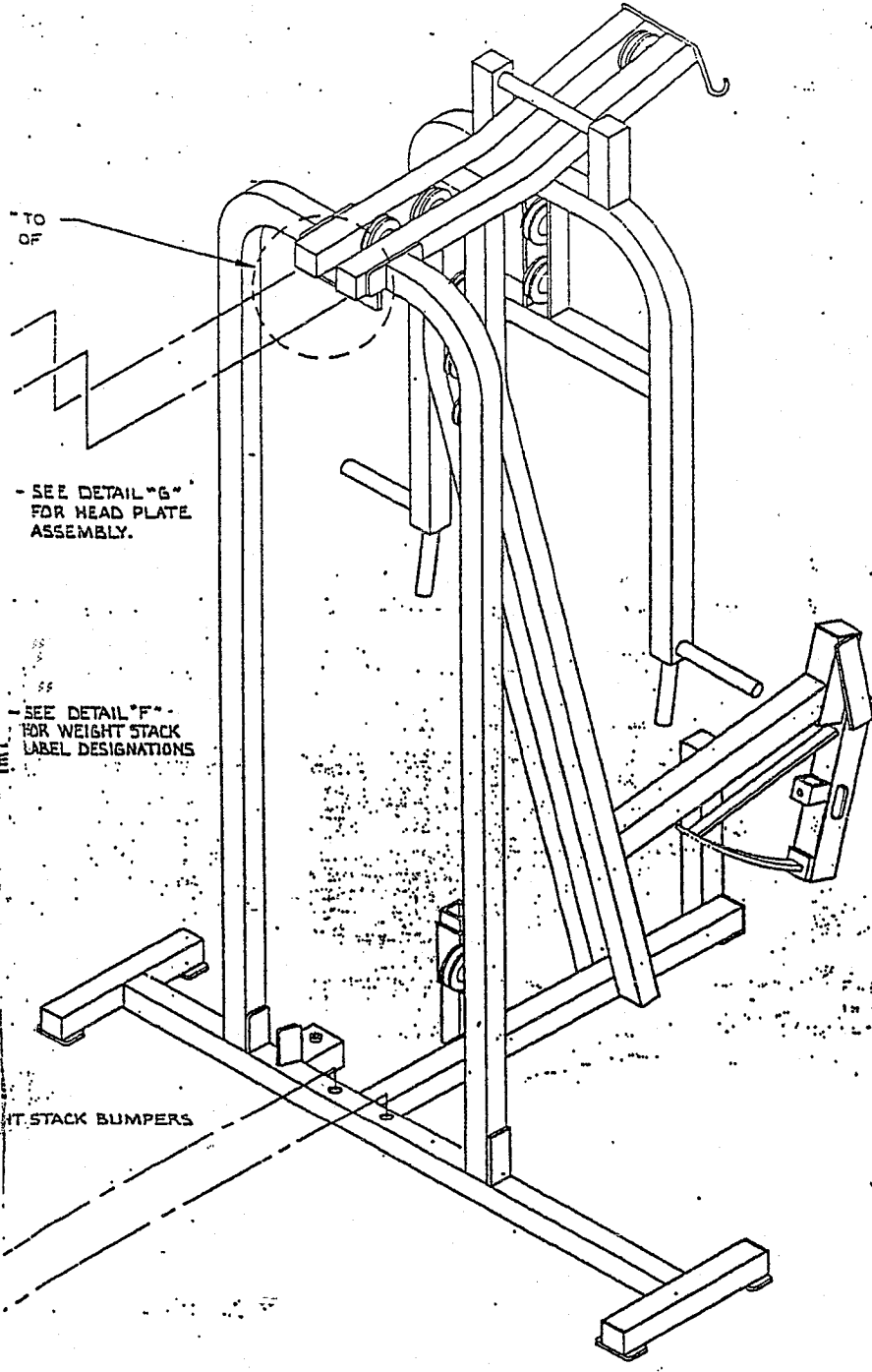

DETAIL "G"

TOLERANCES UNLESS OTHERWISE SPECIFIED		 <b>ParaBody, Inc.</b> RAMSEY, MINNESOTA
DECIMAL		
FRACTIONAL		TITLE <b>EX500 BASE UNIT          ASSY, STEP #3</b>
3		CHKD <i>C. NOVAK</i>
3		APP'D <i>C. NOVAK</i>

DASH NO	DESCRIPTION
---------	-------------

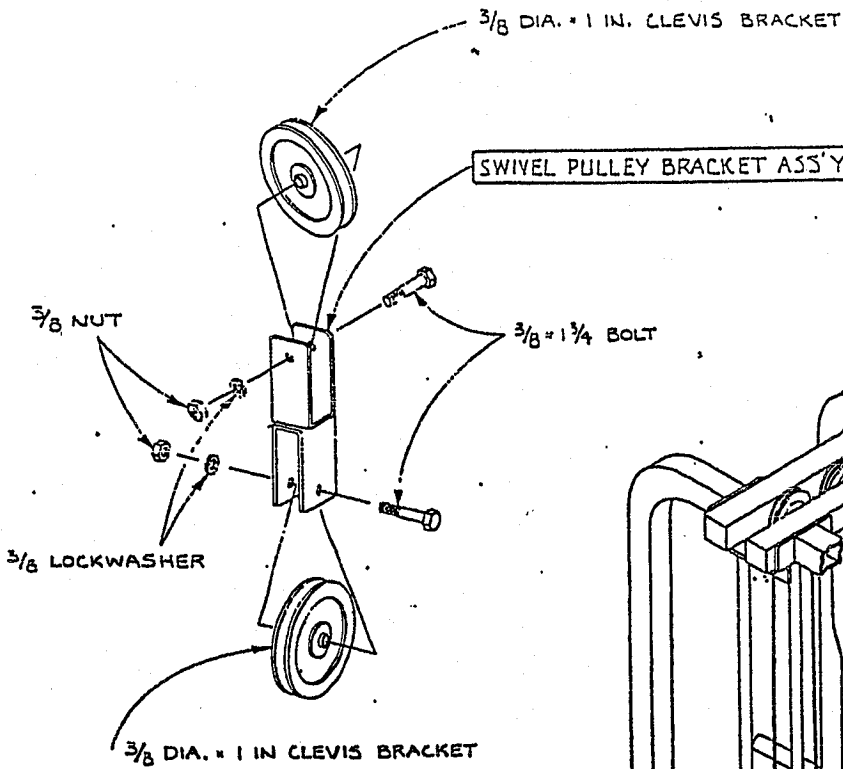

DETAIL "H"

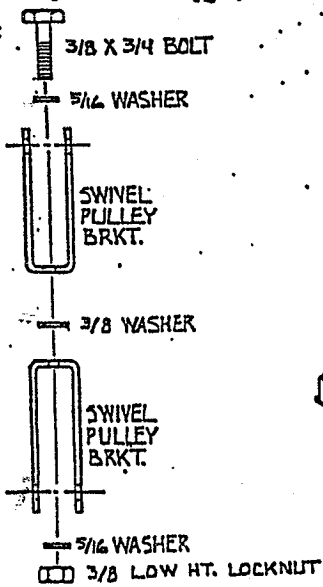

DETAIL "E"

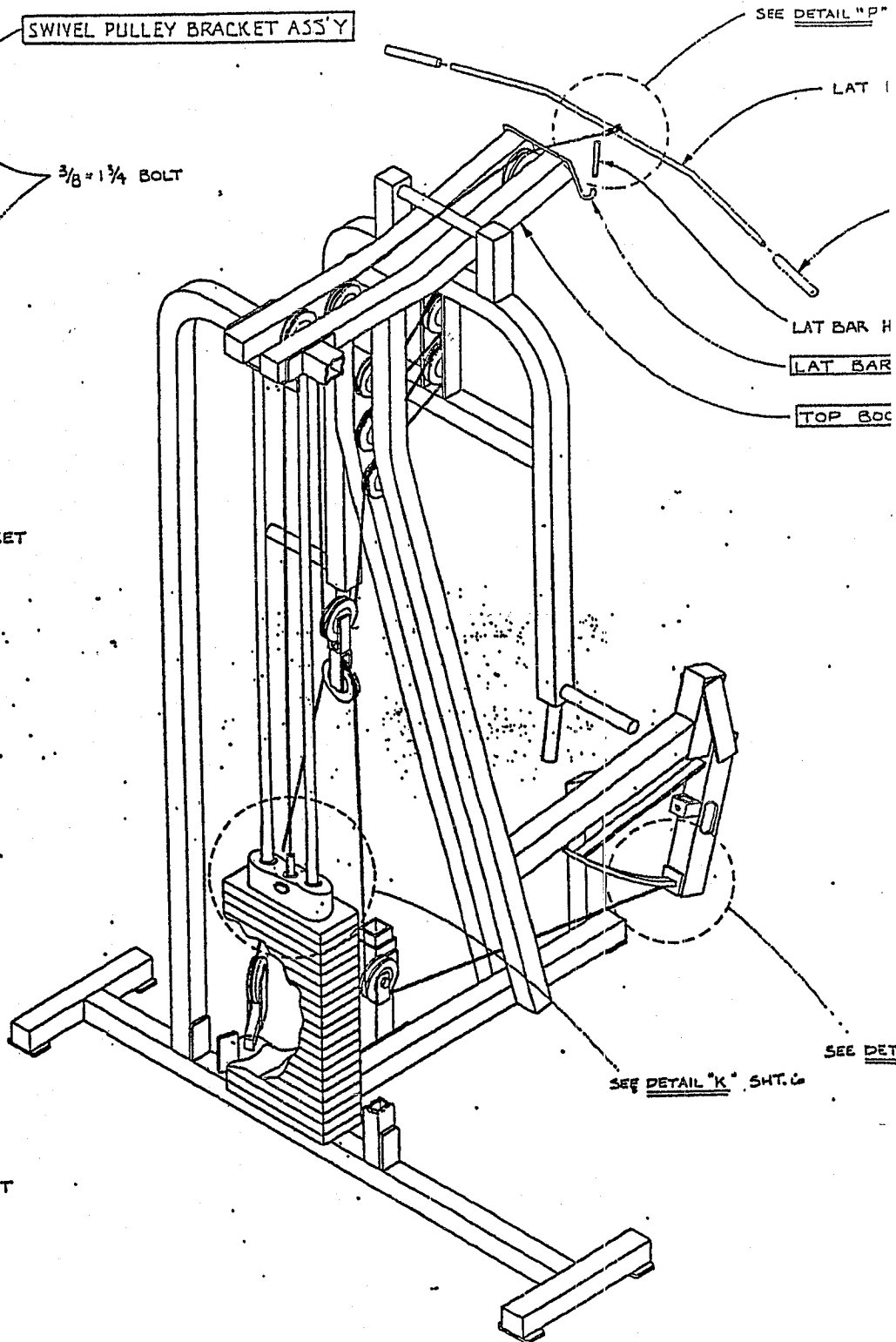





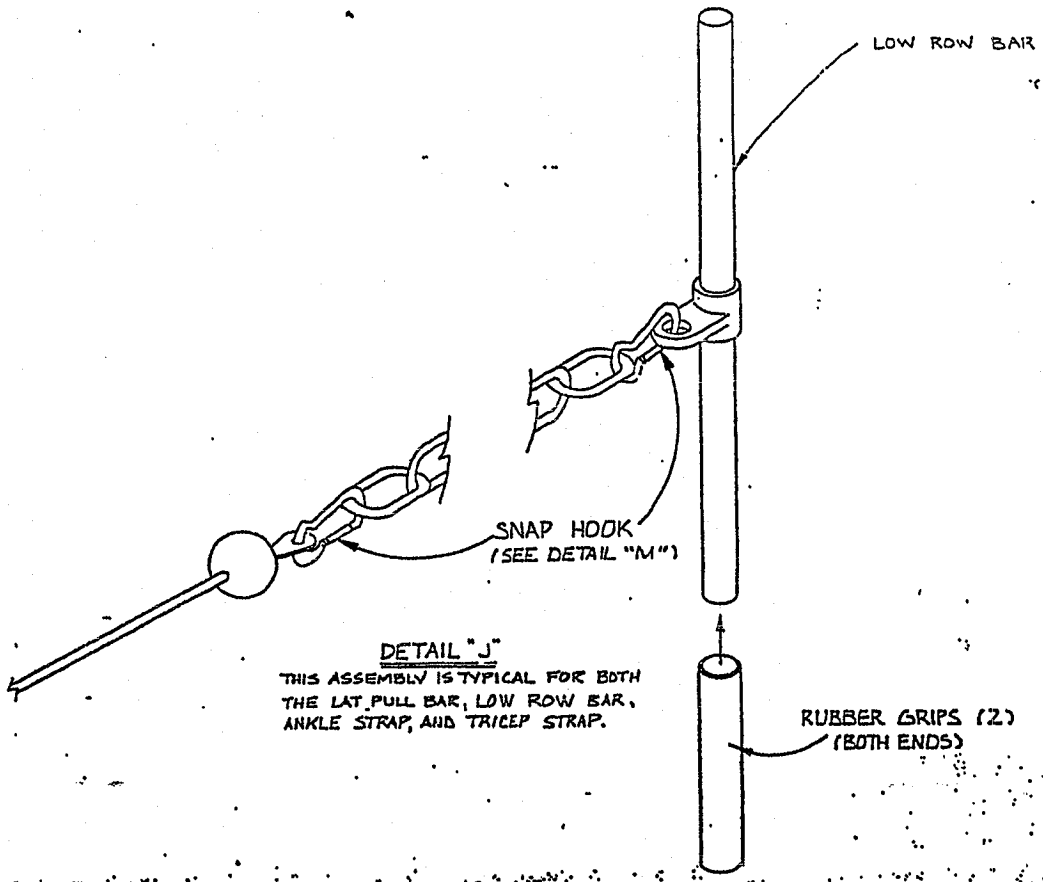

**DETAIL "J"**  
 THIS ASSEMBLY IS TYPICAL FOR BOTH  
 THE LAT PULL BAR, LOW ROW BAR,  
 ANKLE STRAP, AND TRICEP STRAP.

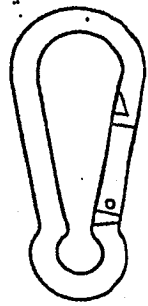

**DETAIL "M"**  
**CAUTION:** MAKE SURE  
 SNAP HOOK IS  
 FASTENED BEFORE  
 DOING EXERCISES

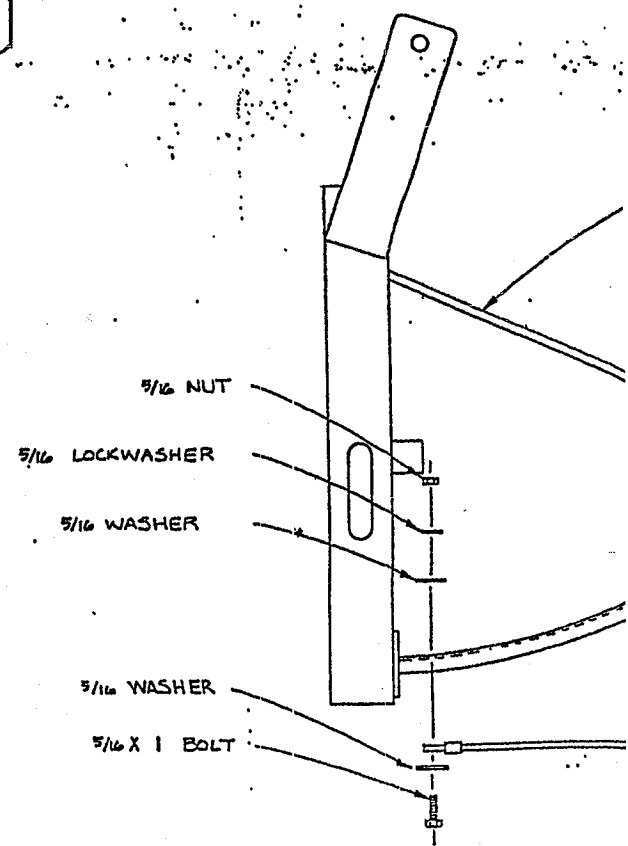

**DETAIL "L"**