

PARABODY®

LP5 LEG PRESS 5

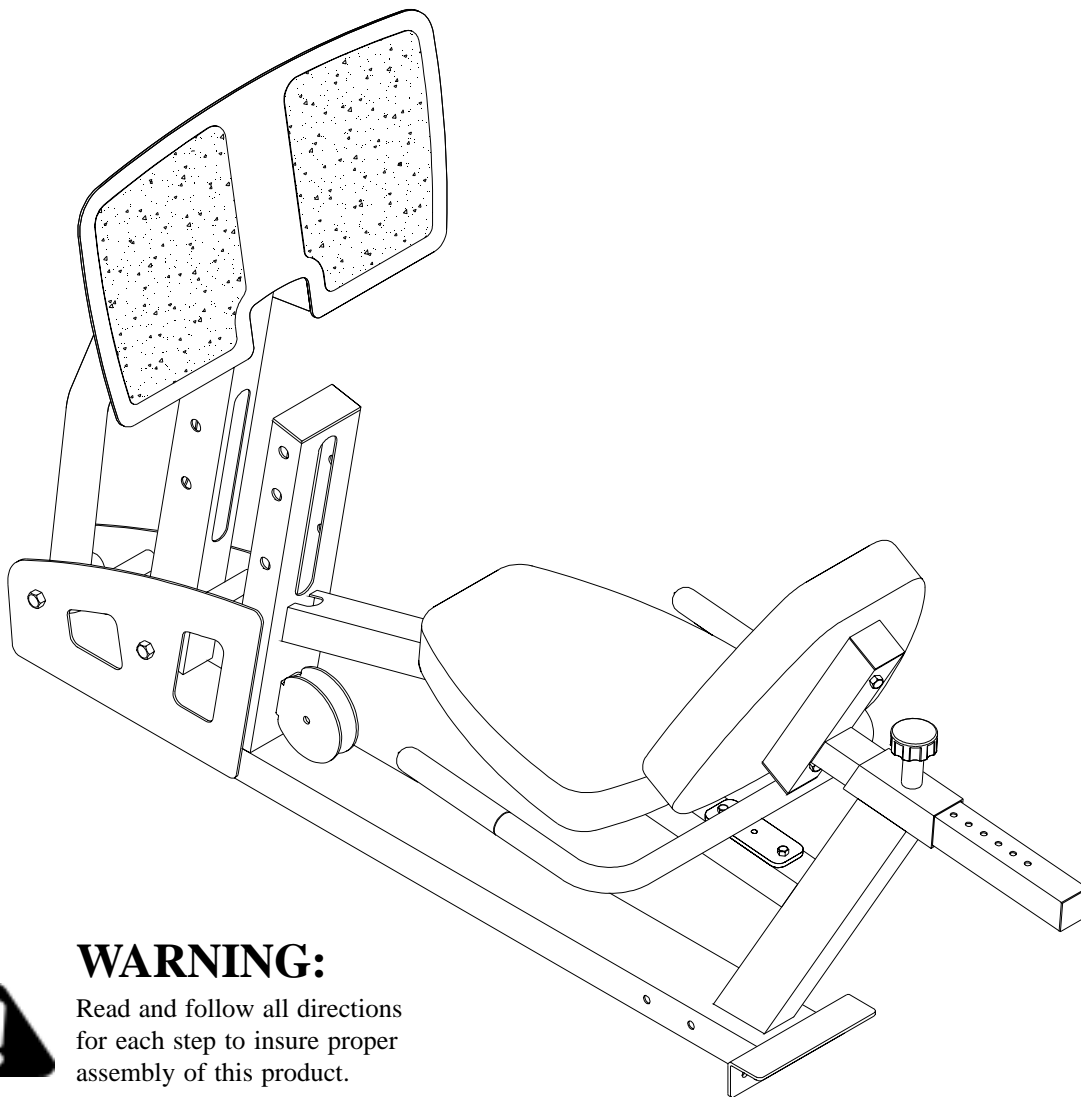

WARNING:

Read and follow all directions for each step to insure proper assembly of this product.



ASSEMBLY INSTRUCTIONS

TABLE OF CONTENTS

Safety Statement.....	2	Assembly Instructions.....	5-12
General Notes.....	3	General Maintenance.....	13
Tools Required.....	3	Warranty Statement.....	14
Parts List.....	4	Product Services.....	15
		Insert-Registration Card	

IMPORTANT SAFETY INFORMATION



THERE IS A RISK ASSUMED BY INDIVIDUALS WHO USE THIS TYPE OF EQUIPMENT. TO MINIMIZE RISK FOLLOW THESE RULES!

1. Before using, read all the warnings and instructions on the use of this machine. Use only for intended exercise. **DO NOT** modify the machine.
2. Obtain a medical exam before beginning any exercise program.
3. Keep body and clothing free of all moving objects.
4. Inspect the machine before use. **DO NOT** use it if it appears damaged. **DO NOT** attempt to fix a broken or jammed machine. Notify your authorized ParaBody dealer before use and have repairs made by an authorized service technician.
5. Be certain that weight pin is completely inserted. Use only the pin provided by the manufacturer. If unsure, call your authorized ParaBody dealer.
6. Never pin the weights or prop plate into an elevated position. **DO NOT** use the machine if found in this condition. **DO NOT** attempt to fix. Notify your authorized ParaBody dealer.
7. Inspect cables and their connections before using machine. Pay particular attention to the cable ends. **DO NOT** attempt to fix. Notify your authorized ParaBody dealer before use and have repairs made by an authorized service technician.
8. Make sure all spring loaded pull pins are fully engaged in the adjustment position and fully tighten thumbscrew before use.
9. Children must not be allowed near this machine. Supervise teenagers.

NOTE: In a continual effort to improve our products, specifications are subject to change
© 2002 Life Fitness, a division of Brunswick Corporation. All rights reserved.
ParaBody is a trademark of Brunswick Corporation

www.parabody.com

IMPORTANT NOTES

Please note:

- * Thank you for purchasing the ParaBody LP5 Leg Press. Please read these instructions thoroughly and keep them for future reference.
- * This product must be assembled on a flat, level surface to assure its proper function. DO NOT securely tighten any frame connections until the entire frame has been assembled, unless otherwise stated.

Tools Required for Assembly

- * 3/4" wrench
- * 9/16" wrench
- * Ratchet with 3/4" and 9/16" sockets
- * Adjustable wrench
- * Tape measure

Bolt Length Ruler

NOTE: BOLT LENGTH IS MEASURED FROM THE UNDERSIDE OF THE HEAD OF THE BOLT.

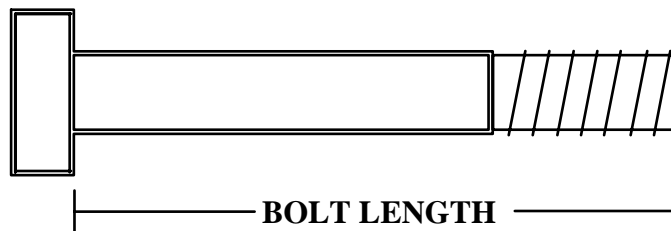

BOLT LENGTH RULER:

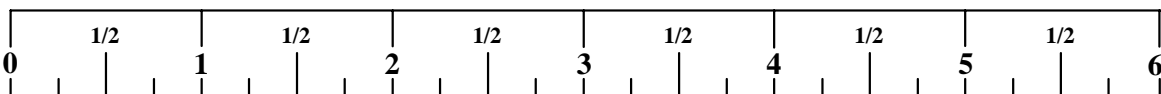

PARTS LIST

KEY	PART #	DESCRIPTION	QTY		KEY	PART #	DESCRIPTION	QTY
1	ACU04-1444	FRAME	1		10	ACUDC1250100020B	3/8" FLAT WASHER	8
2	ACU04-1447	SEAT ADJUST	1		11	ACUDB2E03811000B	3/8" LOCK NUT	2
3	ACU04-1449	HANDLE	1		12	ACUDA1E02143413NB	1/2 X 4-3/4" BOLT	4
4	ACU04-1445	MAIN ARM	1		13	ACUDB2E01212000B	1/2" LOCK NUT	4
5	ACU04-1446	SECOND ARM	1		14	ACU11-0080	SPRING PIN KNOB	1
6	ACU04-1448	FOOTPLATE	1		15	ACU05-0372	3/4 X 4" SHAFT	4
7	ACU02-1298	PULLEY BRACKET	1		16	ACU06-0437	BUMPER, 1-1/2 X 2	2
8	ACU07-0135	PAD	2		17	ACUDACM04006007YB	SET SCREW, M4X0.7X6L	1
9	ACUDA1E03830016NB	3/8 X 3" BOLT	6					

NOTE: Some of the component may be pre-assembled.

For assembly to the GS1, GS2, GS4, GS8 Gym Systems .

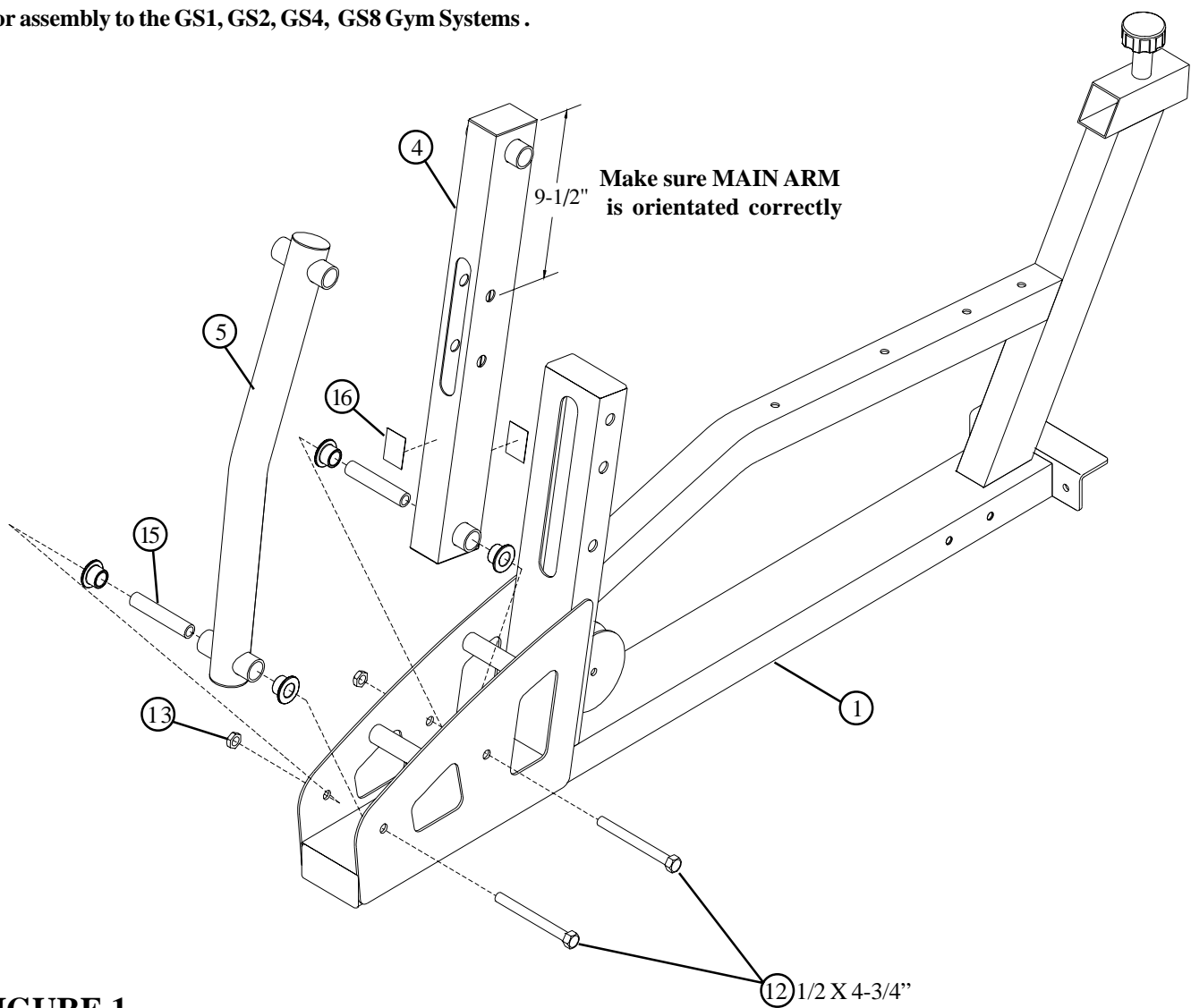
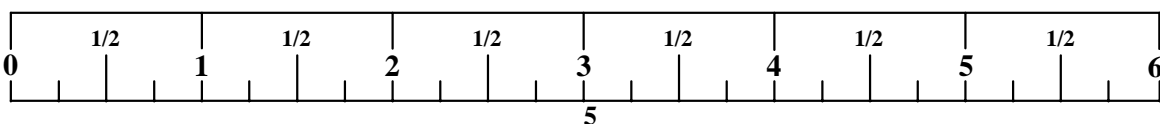

FIGURE 1

STEP 1:

- **NOTE:** Follow STEP 1 for the assembly of the LEG PRESS to the GS1, GS2, GS4 and GS8 Gym Systems. If you have the CM3 or GS6 Gym System proceed to STEP 2.
- **NOTE:** FLANGE BEARINGS SHOULD BE PRE-INSTALLED
- **SECURELY** assemble the SECOND ARM (5) to the FRAME (1) using one 1/2 X 4-3/4" BOLT (12), one 3/4 X 4" SHAFT (15) and one 1/2" LOCK NUT (13). See FIGURE 1.
- **SECURELY** assemble the MAIN ARM (4) to the FRAME (1) using one 1/2 X 4-3/4" BOLT (12), two 3/4" FLANGE BEARINGS (14), one 3/4 X 4" SHAFT (15) and one 1/2" LOCK NUT (13). See FIGURE 1. (**NOTE: Make sure MAIN ARM is orientated correctly, top hole should be 9-1/2" from the top of arm as shown in FIGURE 1.**)
- **SECURELY** assemble two 1-1/2 X 2" BUMPERS (16) to each side of the MAIN ARM (4) where the MAIN ARM (4) contacts the FRAME (1) See FIGURE 1.
- **Proceed to to STEP 3.**



For assembly to the CM3 and GS6 Gym System .

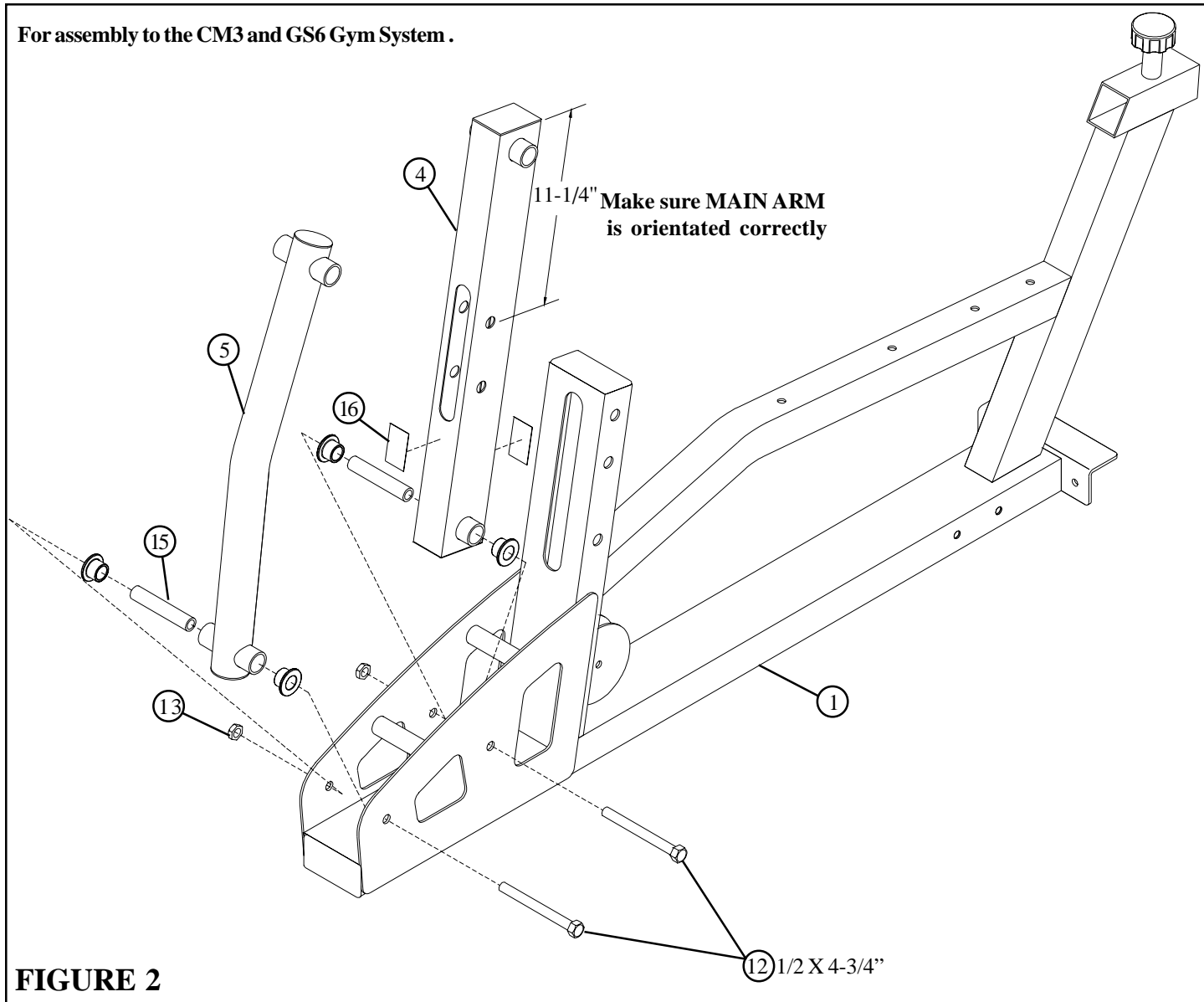

FIGURE 2

STEP 2:

- **NOTE:** Follow **STEP 2** for the assembly of the **LEG PRESS** to the **CM3** and **GS6** Gym System. If you have the **GS1, GS2, GS4** or **GS8** Gym Systems proceed to **STEP 3**.
- **NOTE:** **FLANGE BEARINGS SHOULD BE PRE-INSTALLED**
- **SECURELY** assemble the **SECOND ARM (5)** to the **FRAME (1)** using one **1/2 X 4-3/4" BOLT (12)**, one **3/4 X 4" SHAFT (15)** and one **1/2" LOCK NUT (13)**. See **FIGURE 2**.
- **SECURELY** assemble the **MAIN ARM (4)** to the **FRAME (1)** using one **1/2 X 4-3/4" BOLT (12)**, one **3/4 X 4" SHAFT (15)** and one **1/2" LOCK NUT (13)**. See **FIGURE 2**. (**NOTE: Make sure MAIN ARM is orientated correctly, top hole should be 11-1/4" from the top of arm as shown in FIGURE 2.**)
- **SECURELY** assemble two **1-1/2 X 2 BUMPERS (16)** to each side of the **MAIN ARM (4)** where the **MAIN ARM (4)** contacts the **FRAME (1)** See **FIGURE 2**.
- **Proceed to to STEP 3.**

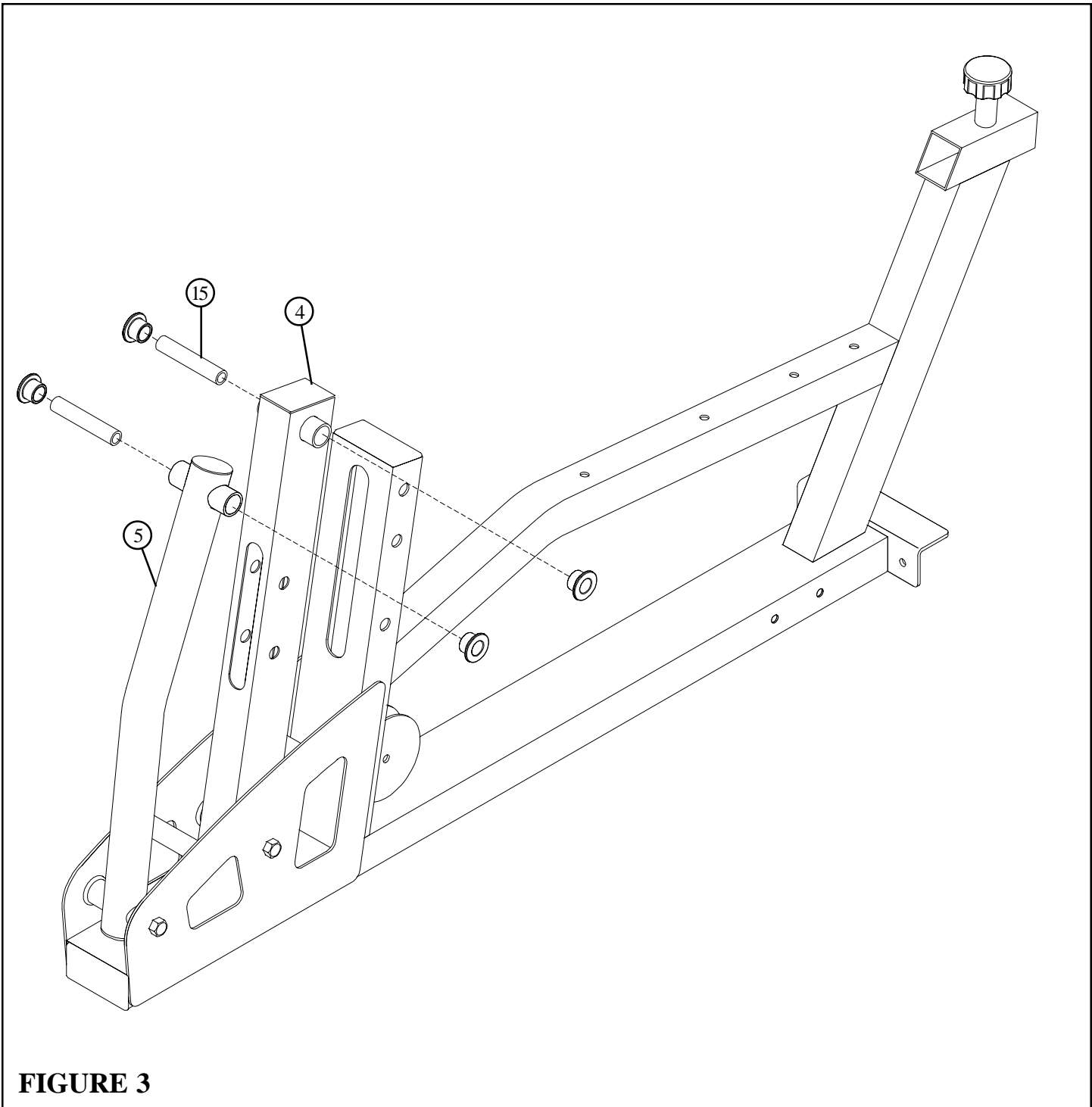
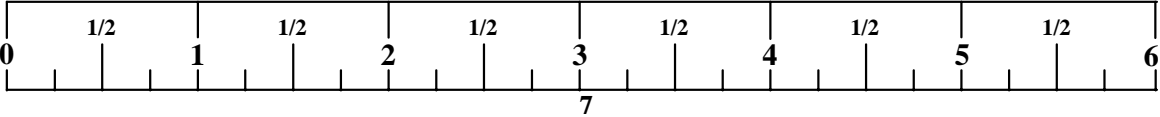

FIGURE 3

STEP 3:

- Insert one 3/4 X 4" SHAFT (15) thru pre-installed FLANGE BEARINGS in the SECOND ARM (5) as shown in FIGURE 3.
- Insert one 3/4 X 4" SHAFT (15) thru pre-installed FLANGE BEARINGS in the MAIN ARM (4) as shown in FIGURE 3.



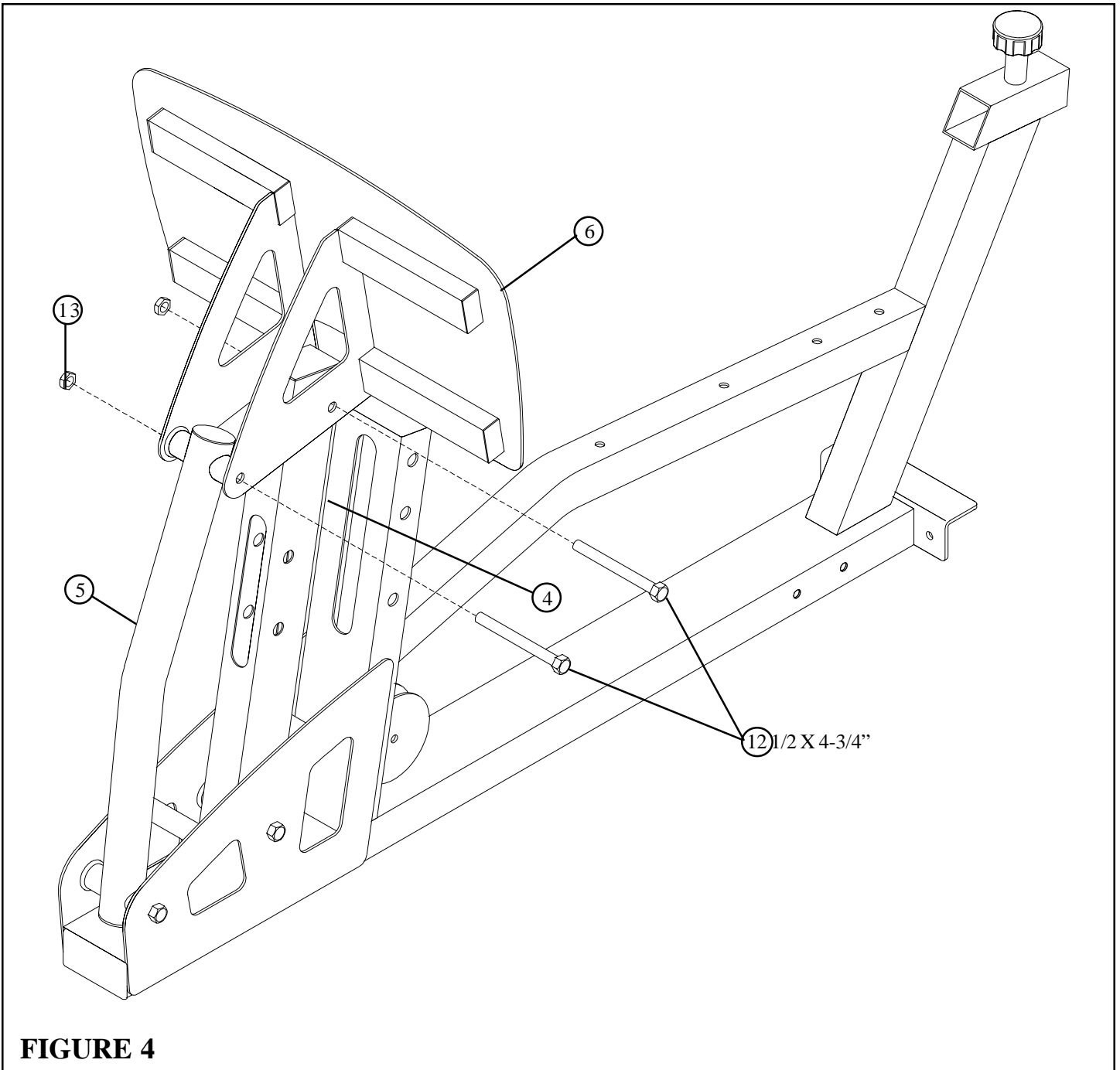
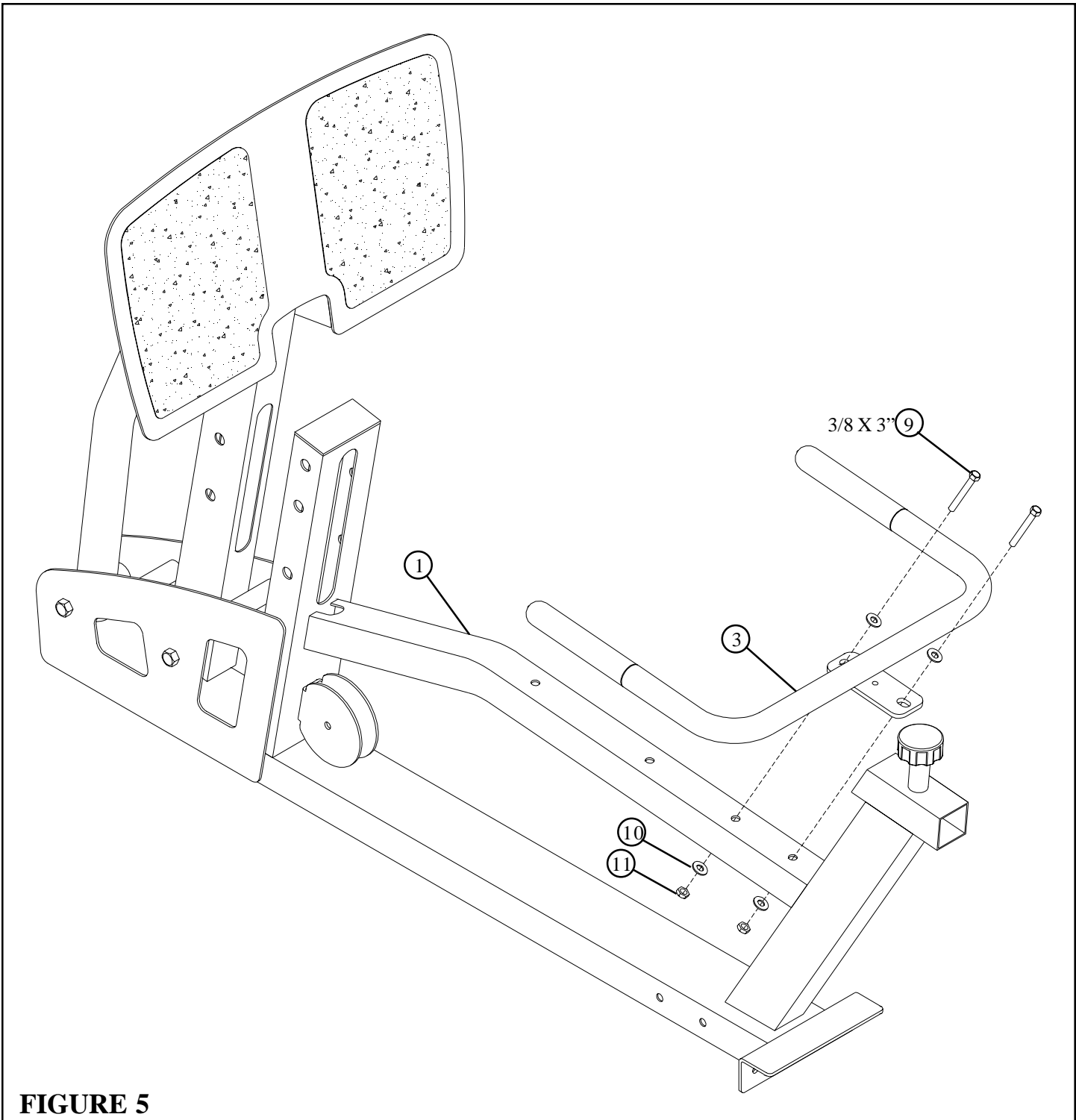

FIGURE 4

STEP 4:

- **SECURELY** assemble the FOOTPLATE (6) to the SECOND ARM (5) and the MAIN ARM (4) using two 1/2 X 4-3/4" BOLTS (12) and two 1/2" LOCK NUTS (13). See FIGURE 4.



STEP 5:

- **SECURELY** assemble the HANDLE (3) to the FRAME (1) using two 3/8 X 3" BOLTS (9), four 3/8" FLATWASHERS (10) and two 3/8" LOCK NUTS (11) as shown in FIGURE 5.

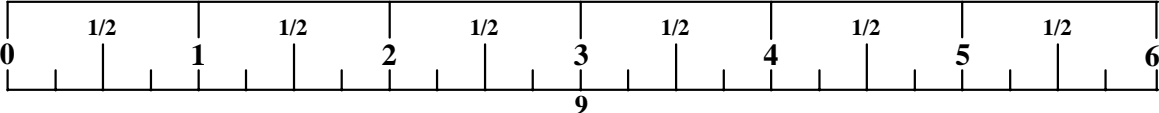

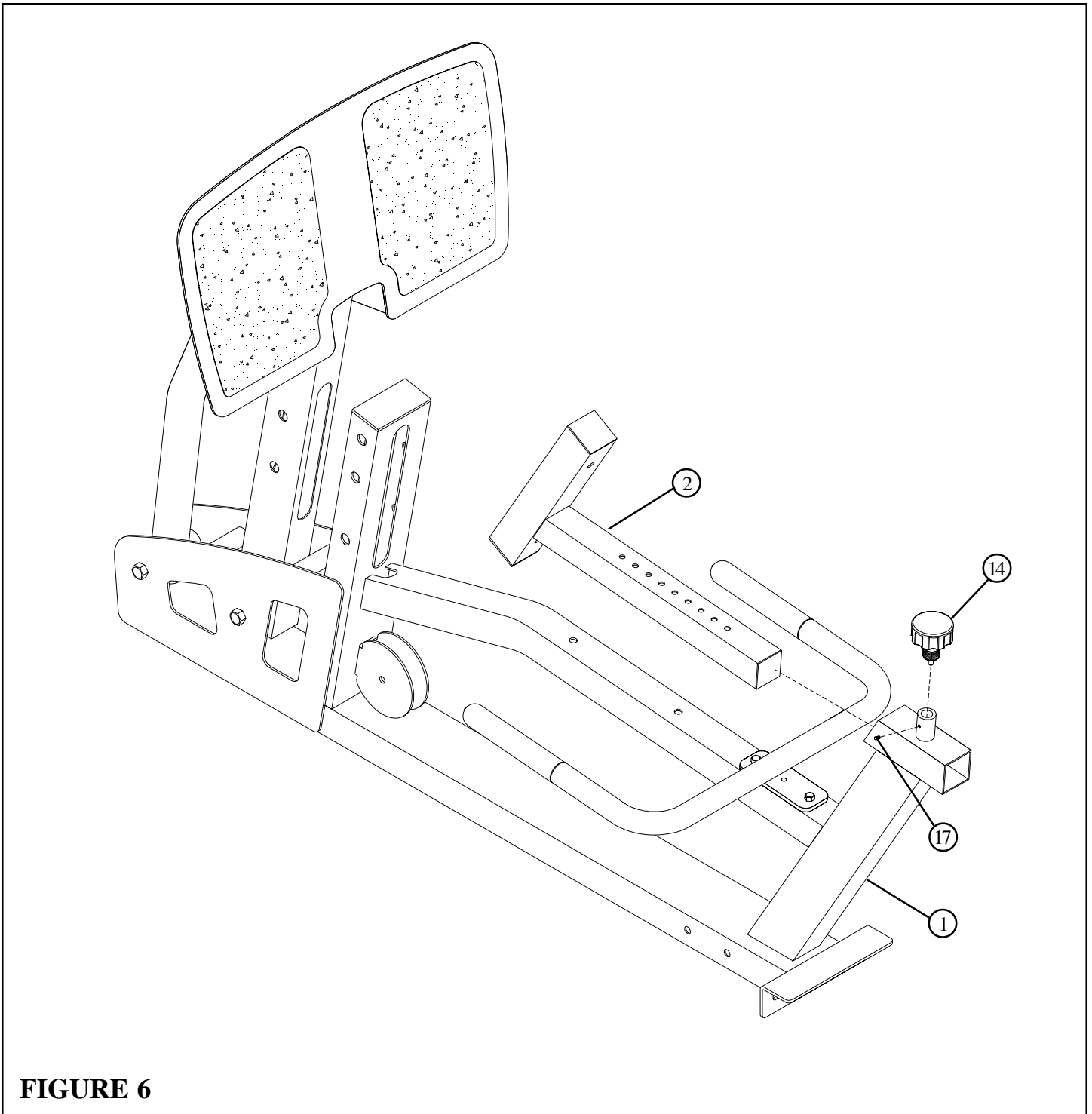

FIGURE 6

STEP 6:

- Securely assemble one PLUNGER PIN (14) to the FRAME (1) as shown. (**NOTE: Screw PLUNGER PIN (14) in all the way**)
- Securely assemble one M4 SET SCREW (17) to the plunger pin barrel on the FRAME (1) then back off 1/4 turn so PLUNGER PIN (14) rotates freely until the threads come in contact with the M4 SET SCREW (17)
- **CAREFULLY** slide the SEAT ADJUST (2) into the FRAME (1) as shown. The SEAT can be adjusted by turning the SPRING PIN KNOB (14) clockwise and pulling. The SEAT can be secured in place by releasing the pin into an adjustment hole and turning clockwise until tight.

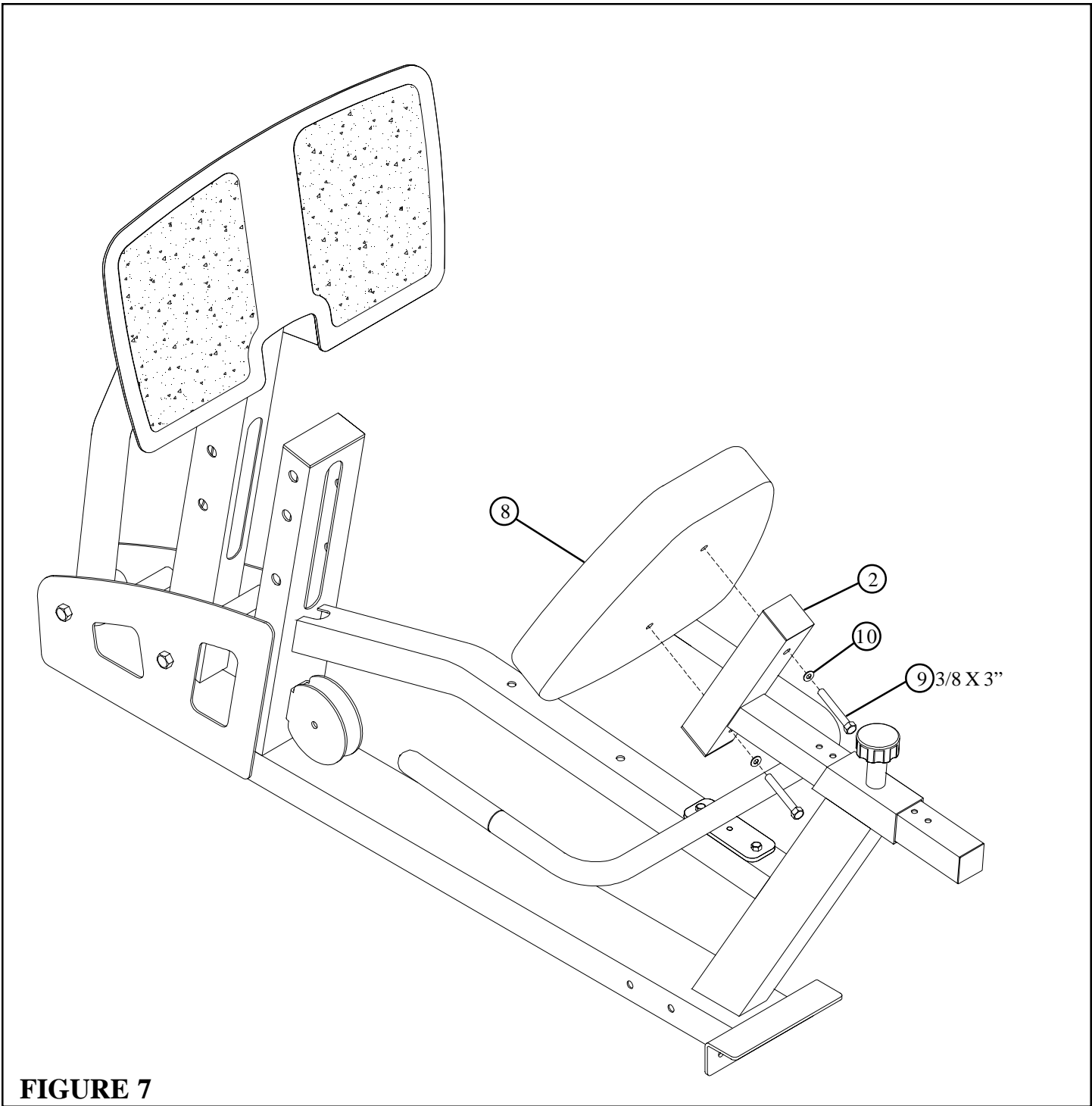
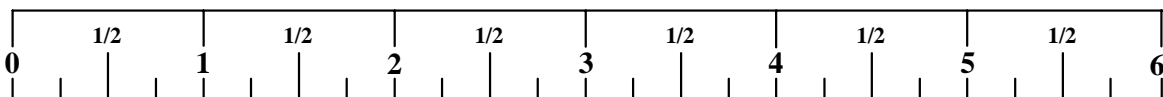

FIGURE 7

STEP 7:

- **SECURELY** assemble one PAD (8) to the SEAT ADJUST (2) using two 3/8 X 3" BOLTS (9) and two 3/8" FLAT WASHERS (10) as shown in FIGURE 7.



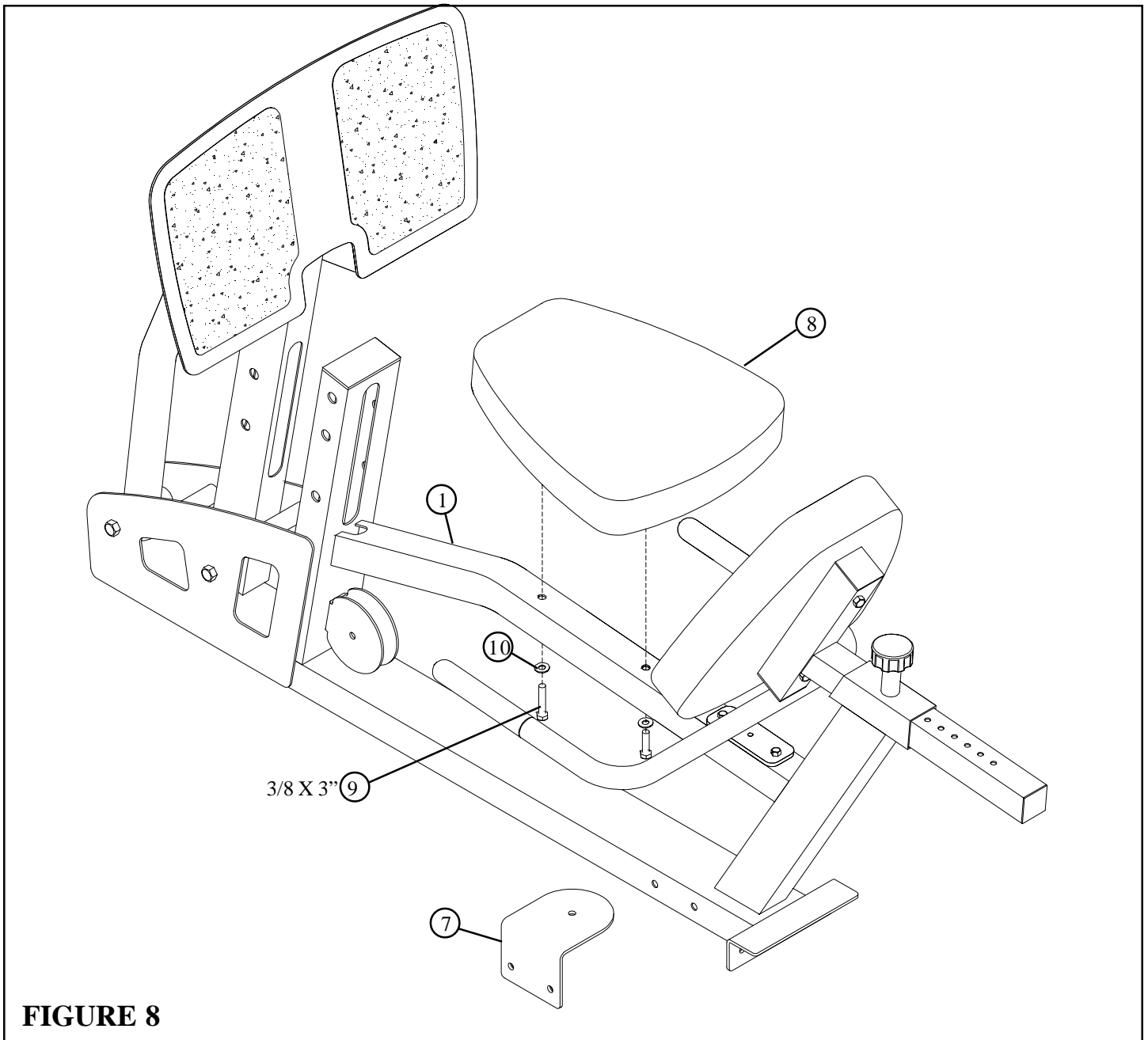

FIGURE 8

STEP 8:

- **SECURELY** assemble one PAD (8) to the FRAME (1) using two 3/8 X 3" BOLTS (9) and two 3/8" FLAT WASHERS (10) as shown in FIGURE 8.
- Refer to the LEG PRESS ADAPTOR assembly instructions to attach the LP5 LEG PRESS to the home gym. The PULLEY BRACKET (7) will be attached at that time.

Thank you for purchasing the Parabody LP5 LEG PRESS. If unsure of proper use of equipment, call your local Parabody distributor or call the Parabody customer service department at (800) 328-9714.

MAINTENANCE

Please note:

- * We recommend cleaning your product (pads and frame) on a regular basis, using warm soapy water. Touch-up paint can be purchased from your ParaBody customer service representative at (800) 328-9714.

- * Inspect equipment daily. Tighten all loose connections and replace worn parts immediately. Failure to do so may result in serious injury.

- * **PLEASE RECORD THE INFORMATION REQUESTED BELOW. IN THE EVENT YOU MAY NEED SERVICE YOU WILL BE ASKED FOR THIS INFORMATION. REMEMBER TO FILL OUT YOUR WARRANTY REGISTRATION CARD AND MAIL BACK.**

MODEL # _____

SERIAL # _____

DATE OF PURCHASE: _____

DEALERS NAME: _____

DEALERS PHONE # _____

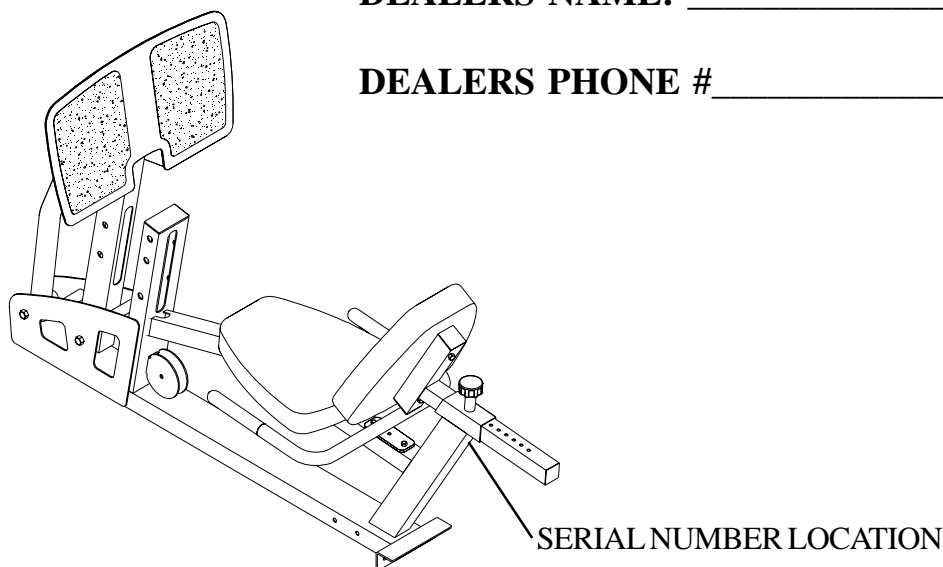

Thank you for purchasing the ParaBody LP5 Leg Press.

LIMITED WARRANTY

ParaBody extends the following LIMITED WARRANTY to the original owner of the ParaBody products. The Warranty terms apply to IN HOME USE ONLY.

1. **LIMITED WARRANTY ON FRAME AND WELDS.** If the frame of the ParaBody product or a weld should crack or break, it will be repaired or replaced by ParaBody. Terms: Lifetime – for so long as the Customer owns the ParaBody product.
2. **LIMITED WARRANTY ON PARTS.** If the following parts are defective in material or workmanship, ParaBody will supply replacement parts: all bolts, nuts, washers, bearings, bushings, pulleys, thumbscrews, collars, cable retaining clips, adjustable pre-stretch slides, roller pad shafts, allen head bolts, weight selector pin, weight stack shaft, set screws, protector caps, adjustment chain, cotter pin, plunger, spring and knob. Terms: Lifetime – for so long as the Customer owns the ParaBody product.
3. **LIMITED WARRANTY ON CABLES AND UPHOLSTERY.** If the coated cables or upholstery are defective in material or workmanship, ParaBody will repair or replace them, at its option. Terms: Three (3) years.
4. **CONDITIONS AND EXCEPTIONS.** Any product misuse, abuse or alteration, any attempt to repair by a person other than an authorized ParaBody Service Center, any improper assembly, accident, or any other condition resulting from occurrences beyond the control of ParaBody will void this Limited Warranty.
5. **REPLACEMENT AND REPAIR EXPENSES.** ParaBody will provide only replacement parts or repair under this warranty. The Owner is responsible for all other costs. Such costs may include, but are not limited to: a. labor charges for service, removal, repair or reinstallation of the ParaBody product or any component part; b. shipping, delivery, handling and administrative charges for returning parts to ParaBody; and c. all necessary or incidental costs related to installation of the replacement parts.
6. **SHIPPING.** If shipping by the Owners is deemed necessary (in sole discretion of ParaBody), parts should be shipped in their original carton or equivalent packaging, fully insured with shipping charges prepaid. ParaBody will not assume any responsibility for any loss or damage incurred in shipping.
7. **CLAIM PROCEDURES.** If service on your ParaBody product is required during the warranty period, please contact our Customer Service Department at 1-800-328-9714 for instructions regarding returning or replacing parts. Please have available the following information: (i) the dealer's name; (ii) the date of purchase; (iii) the serial # (s) of your product (the serial number location is called out on the final assembly drawing included with your assembly instruction); (iv) a description of the nature of the problem.
8. **OWNER'S RIGHT.** This Limited Warranty gives you specific legal rights. You may also have other rights, which vary depending on local law.
9. **LIMITATION OF IMPLIED WARRANTIES.** All implied warranties, except to the extent prohibited by applicable law, shall have no greater duration than the warranty period set forth above. There are no warranties which extend beyond the description in this Limited Warranty. Because local laws do not allow limitations on how long an implied warranty lasts, the above limitations may not apply to you.
10. **DISCLAIMER.** No other express warranty has been made or will be made on behalf of ParaBody with respect to any ParaBody product or the operation, repair or replacement of any ParaBody product. ParaBody shall not be responsible for injury, loss of use of the ParaBody product, inconvenience, loss or damage to personal property, whether direct or indirect, and incidental or consequential damages, so the above limitation or exclusion may not apply to you.

NOTES:

LIFE FITNESS

14150 Sunfish Lake Blvd. Ramsey Minnesota, 55303 U.S.A.

Tel: 763.323.4500 Fax: 763.323.4797

800.328.9714 (Toll-free within the U.S. and Canada)

www.parabody.com

INTERNATIONAL OFFICES

Life FitnessAtlantic BV
Atlantic Headquarters
Bijdorpplein 25-31
2992 LB Barendrecht
The Netherlands
Phone: (180) 646 666
Fax: (180) 646 703

Life Fitness (UK) Ltd.
Queen Adelaide
Ely, Cambs CB7 4UB
United Kingdom
Phone CSS: (01353) 665507
Fax CSS: (01353) 666719

Life Fitness EUROPE GmbH
Siemensstrasse 3
85716 Unterschleissheim
Germany
Phone: (089) 31 77 51-0
Fax: (089) 31 77 51 99

Life Fitness Benelux N.V.
Bijdorpplein 25-31
2992 LB Barendrecht
The Netherlands
Phone: 31 (180) 64 66 69
Fax: 31 (180) 64 66 99

Life Fitness Italia S.R.L.
Via Elvas 92
39042 Bressanone
Italy
Phone: 39 (472) 835-470
Fax: 39 (472) 833-150

Life Fitness Japan
8/F, Nippon Brunswick Building
5-27-7 Sendagaya
Shibuya-Ku, Tokyo 151-0051
Japan
Phone: 81 (3) 3359-4309
Fax: 81 (3) 3359-4307

Life Fitness Asia Pacific Limited
Room 2610, Miramar Tower
132 Nathan Road, Tsimshatsui
Kowloon, Hong Kong
Phone: (852) 2891-6677
Fax: (852) 2575-6001

Life Fitness Do Brazil
Al. Rio Negro, 433-Predio 2-Sala 2
3º andar (Confab)
Aplhaville-Barueri-Sao Paulo
CEP: 06454-904
Brazil
Phone: 55 (11)7295-2217
Fax: 55 (11) 7295-2218