

PARABODY

Serious Steel

893103 PRO SYSTEM

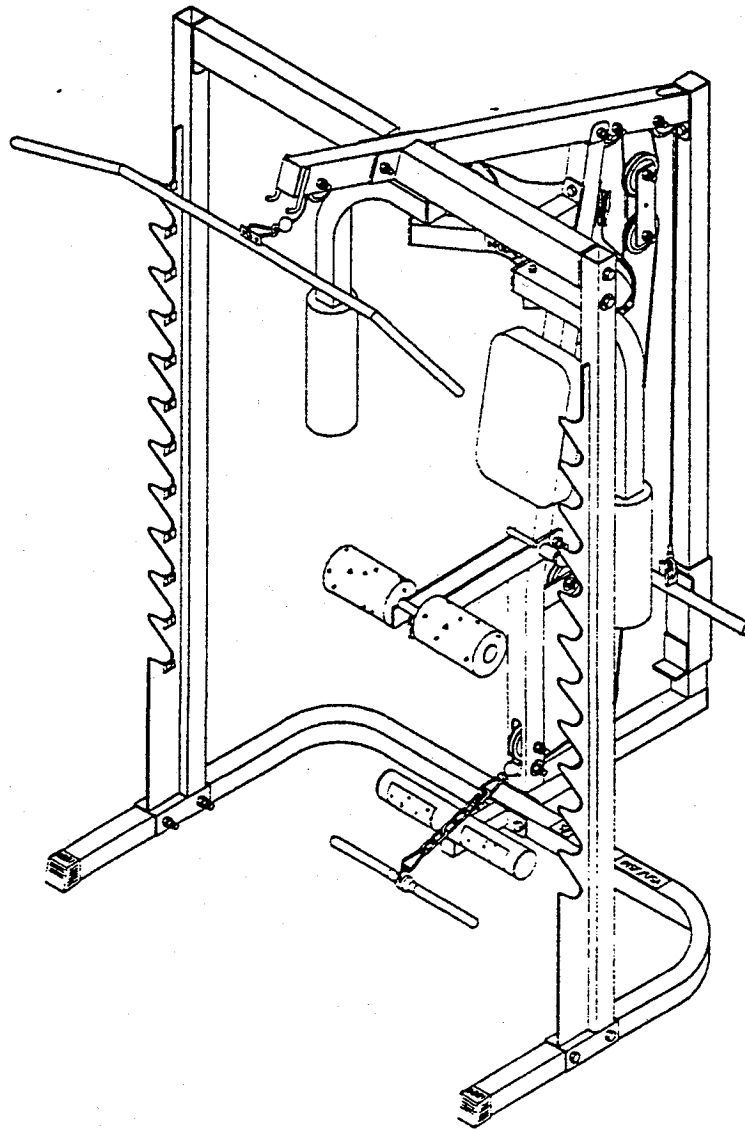

ASSEMBLY INSTRUCTIONS

IMPORTANT NOTES

WELCOME TO THE WORLD OF *Serious Steel!*

Please note:

- * Thank you for purchasing the Parabody 893103 PRO SYSTEM. Please read these instructions thoroughly and keep them for future reference. This product must be assembled on a flat, level surface to assure its proper function.
- * We recommend cleaning your product (pads and frame) on a regular basis, using warm soapy water. Touch-up paint can be purchased from your Parabody customer service representative at (800) 328-9714.

There is a risk assumed by individuals who use this type of equipment. To minimize risk, please follow these rules:

1. Inspect equipment daily. Tighten all loose connections and replace worn parts immediately. Failure to do so may result in serious injury.
2. Do not allow minors or children to play on or around this equipment.
3. Exercise with care to avoid injury.
4. If unsure of proper use of equipment, call your local Parabody distributor or call the Parabody customer service department at (800) 328-9714.
5. Consult a physician before beginning any exercise program.

Tools Required for Assembly

- * 3/4" wrench
- * 9/16" wrench
- * Ratchet with 3/4" and 9/16" sockets
- * Adjustable wrench
- * Tape measure

Bolt Length Ruler

NOTE: BOLT LENGTH IS MEASURED FROM THE UNDERSIDE OF THE HEAD OF THE BOLT.

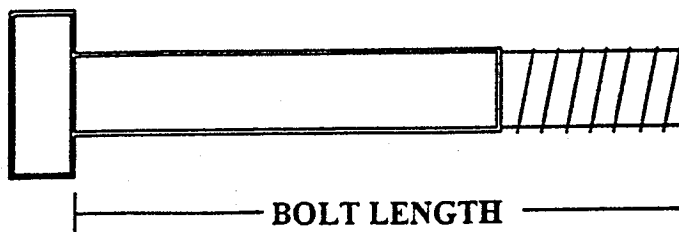

BOLT LENGTH RULER:

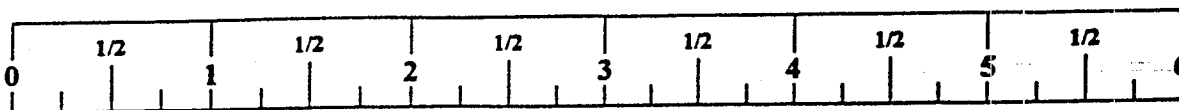

PARTS LIST

KEY	PART #	DESCRIPTION	QTY	KEY	PART #	DESCRIPTION	QTY
1	656603	UPRIGHT FRAME	1	29	3102933	3/8 X 2" BOLT	7
2	6566702	TOP BOOM	1	30	3102502	1/2" WASHER	3
3	6546302	CARRIAGE	1	31	3102501	3/8" WASHER	6
4	6566903	BENT TUBE	1	32	3102602	1/2" LOCK WASHER	3
5	6567002	UPRIGHT	2	33	3102601	3/8" LOCK WASHER	2
6	6581102	LAT BAR	1	34	3102801	1/2" LOCK NUT	9
7	6569802	BOOM SUPPORT LEFT	1	35	3102804	1/2" LOW HT LOCK NUT	1
8	6567302	BOOM SUPPORT RIGHT	1	36	3102802	3/8" LOCK NUT	17
9	6567502	SAFETY RAIL	2	37	3103801	SNAP LINK	3
10	6567803	SWIVEL KNEE SUPPORT	1	38	3108102	QUICK LINK	2
11	6516502	PULLEY BRACKET	1	39	6075906	CHAIN	1
12	6568102	LOW ROW ATTACHMENT	1	40	6412001	3/8" SPRING PIN ASSEMBLY	3
13	6568303	BEARING HOUSING	1	41	3104901	3/4" FLANGE BEARING	4
14	6568603	PEC ARM RIGHT	1	42	6480301	3/8" FLANGE SPACER	8
15	6568703	PEC ARM LEFT	1	43	6145801	THUMBSCREW	2
16	6570403	CENTER PULLEY BRACKET	1	44	6692601	3 X 2" END CAP	1
17	6542402	1-3/4 X 5-1/4" PLATE	2	45	3119301	2-1/2" ROUND END CAP	2
18	6274402	LOW ROW BAR	1	46	6236701	1-3/4" SQ. END CAP	1
19	6597402	BACK PAD	1	47	6405201	2" SQ. END CAP	8
20	6194601	4 X 7" ROLLER PAD	2	48	6467001	COVER CAP	2
21	6176201	4 X 12" ROLLER PAD	2	49	6484101	STARLOCK COLLAR	2
22	6189501	UPRIGHT LABELS	2	50	3103102	1 X 8" GRIP	4
23	3116201	3-1/2" PULLEY	11	51	3116001	1-1/4" SQ. RUBBER BUMPER	1
24	6576201	PEC CABLE	1	52	3120702	3/4" CAP NUT	2
25	6492201	LAT & LOW ROW CABLE	2	53	6140701	1" SQ. GLIDE	10
26	3102918	1/2 X 3-1/4" BOLT	7	54	6416601	1-1/2 X 3/4" GLIDE	3
27	3102910	1/2 X 3" BOLT	6	55	6177001	NON-SKID STRIP	2
28	3102922	3/8 X 2-3/4" BOLT	12	56	6533501	CABLE RETAINING CLIP	4

STEP 1:

- Insert one 1-3/4" SQ. END CAP (46) to the LOW ROW ATTACHMENT (12) as shown in FIGURE 1.
- Insert two 2-1/2" ROUND END CAPS (45) to the LOW ROW ATTACHMENT (12) as shown in FIGURE 1.
- Attach two NON-SKID STRIPS (55) to the LOW ROW ATTACHMENT (12) as shown in FIGURE 1.

FIGURE 1

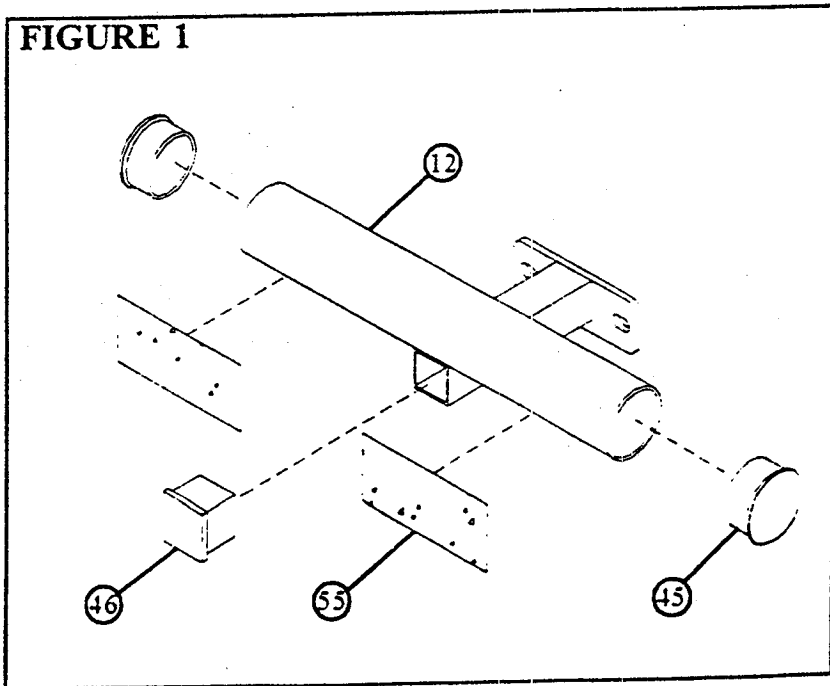

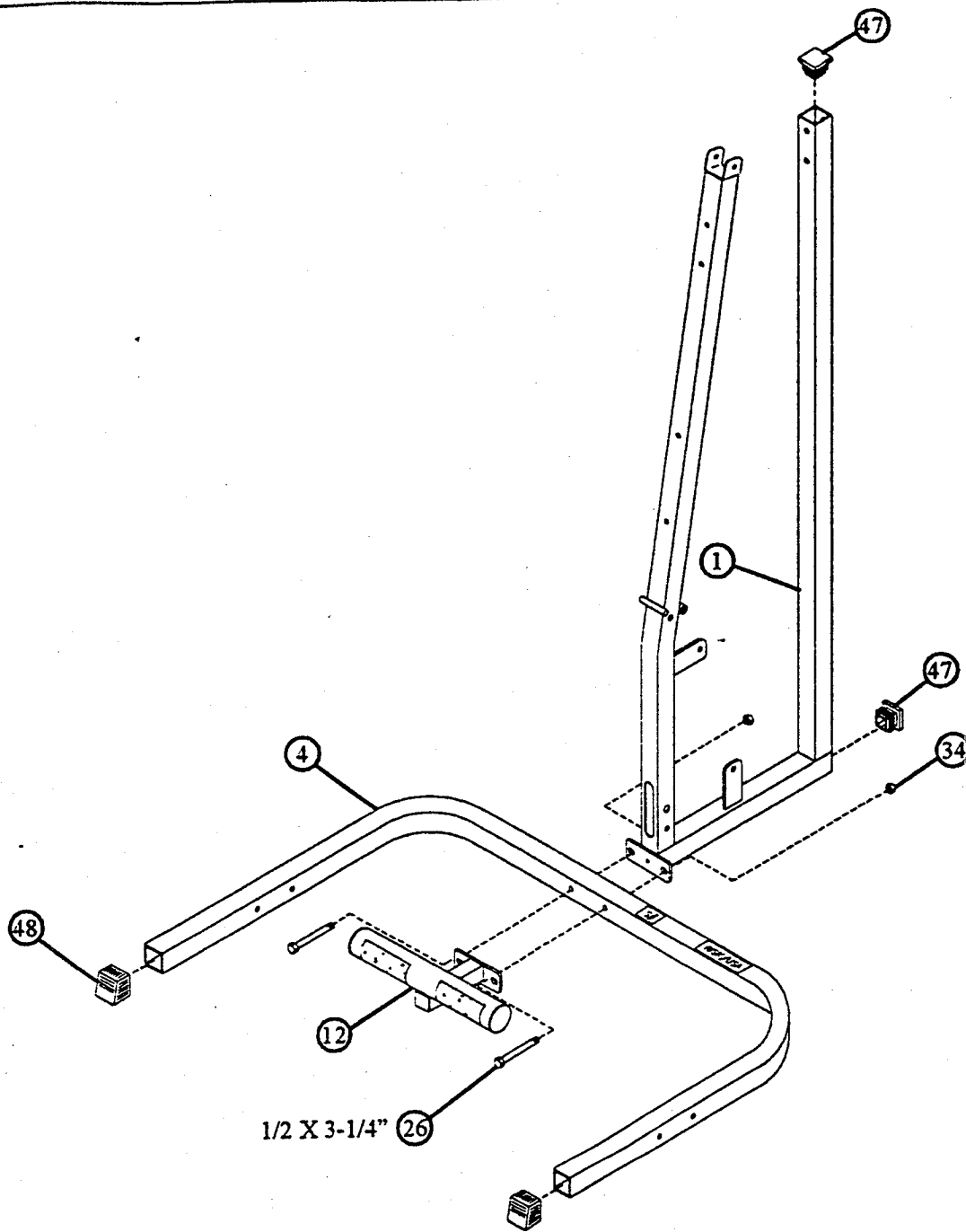
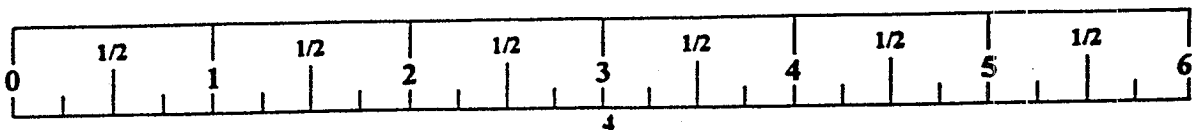

FIGURE 2

STEP 2:

- Assemble two COVER CAPS (48) to the ends of the BENT TUBE (4) as shown in FIGURE 2.
- Insert two 2" SQ. END CAPS (47) to the ends of the UPRIGHT FRAME (1) as shown in FIGURE 2.
- **SECURELY** assemble the LOW ROW ATTACHMENT (12) to the BENT TUBE (4) and UPRIGHT FRAME (1) using two 1/2 X 3-1/4" BOLTS (26) and two 1/2" LOCKNUTS (34) as shown in FIGURE 2.



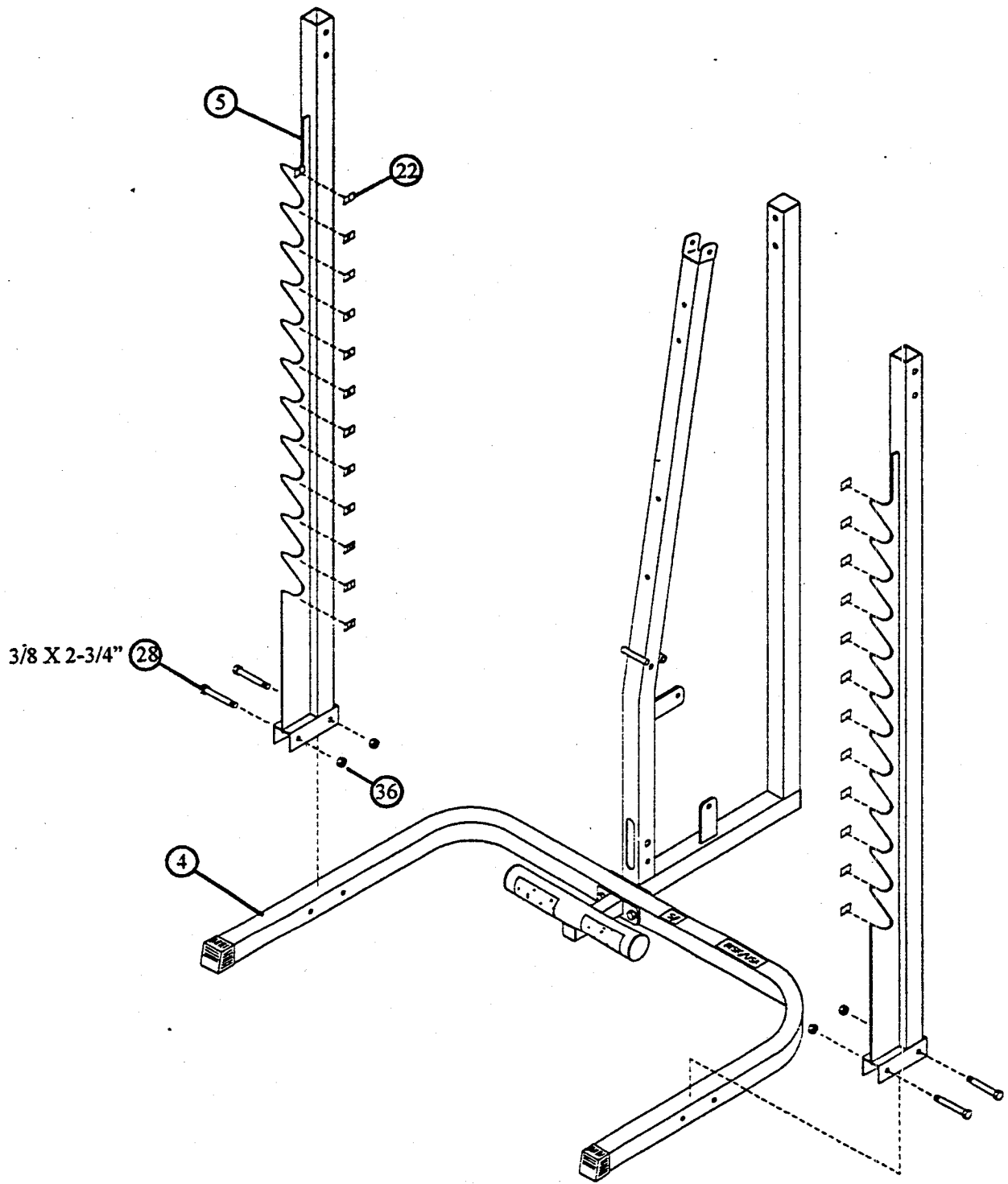

FIGURE 3

STEP 3:

- **LOOSELY** assemble the UPRIGHTS (5) to the BENT TUBE (4) using four 3/8 X 2-3/4" BOLTS (28) and four 3/8" LOCK-NUTS (36) as shown in FIGURE 3.
- Attach UPRIGHT LABELS (22) to both of the UPRIGHTS (5) as shown in FIGURE 3.

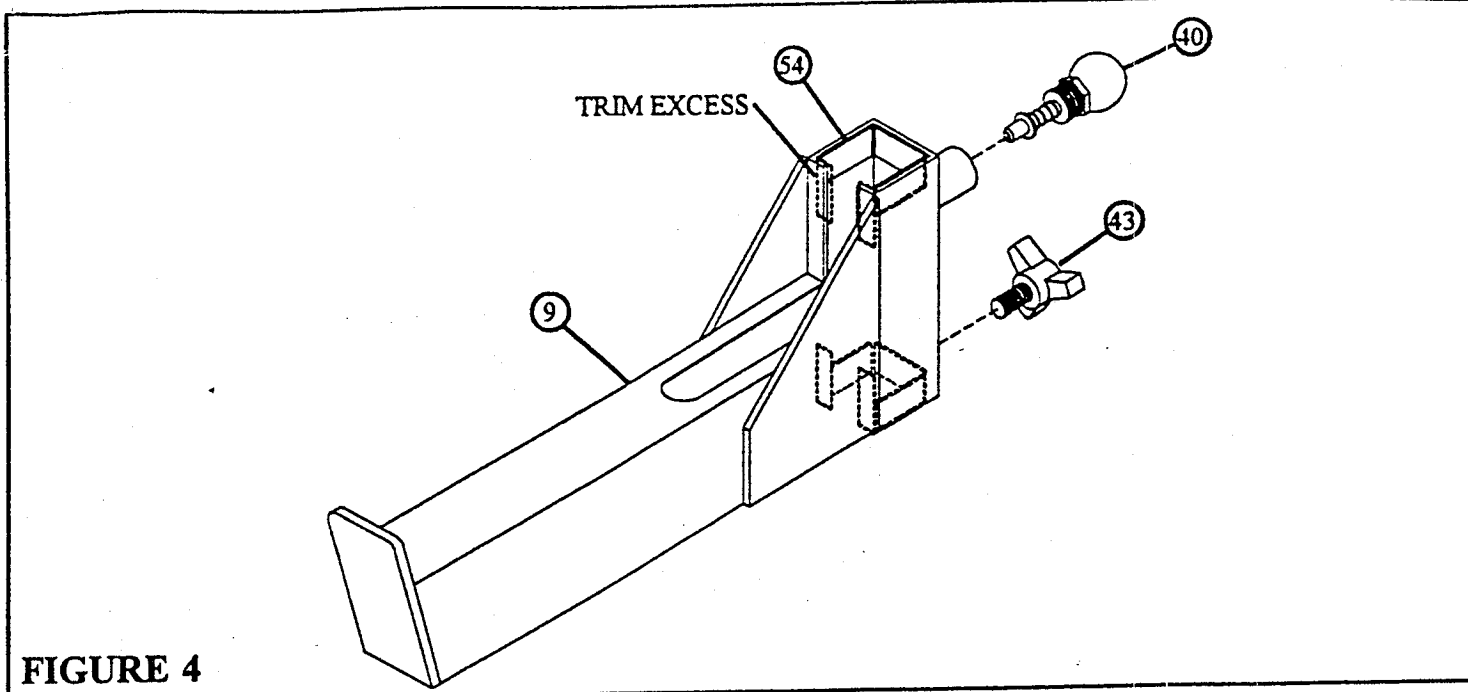

FIGURE 4

STEP 4:

- Attach ten 1-1/2 X 3/4" GLIDES (54) to both SAFETY RAILS (9) as shown in FIGURE 4.
- SECURELY assemble one SPRING PIN ASSEMBLY (40) to both SAFETY RAILS (9) as shown in FIGURE 4.
- Thread one THUMBSCREW (43) into both SAFETY RAILS (9) as shown in FIGURE 4.

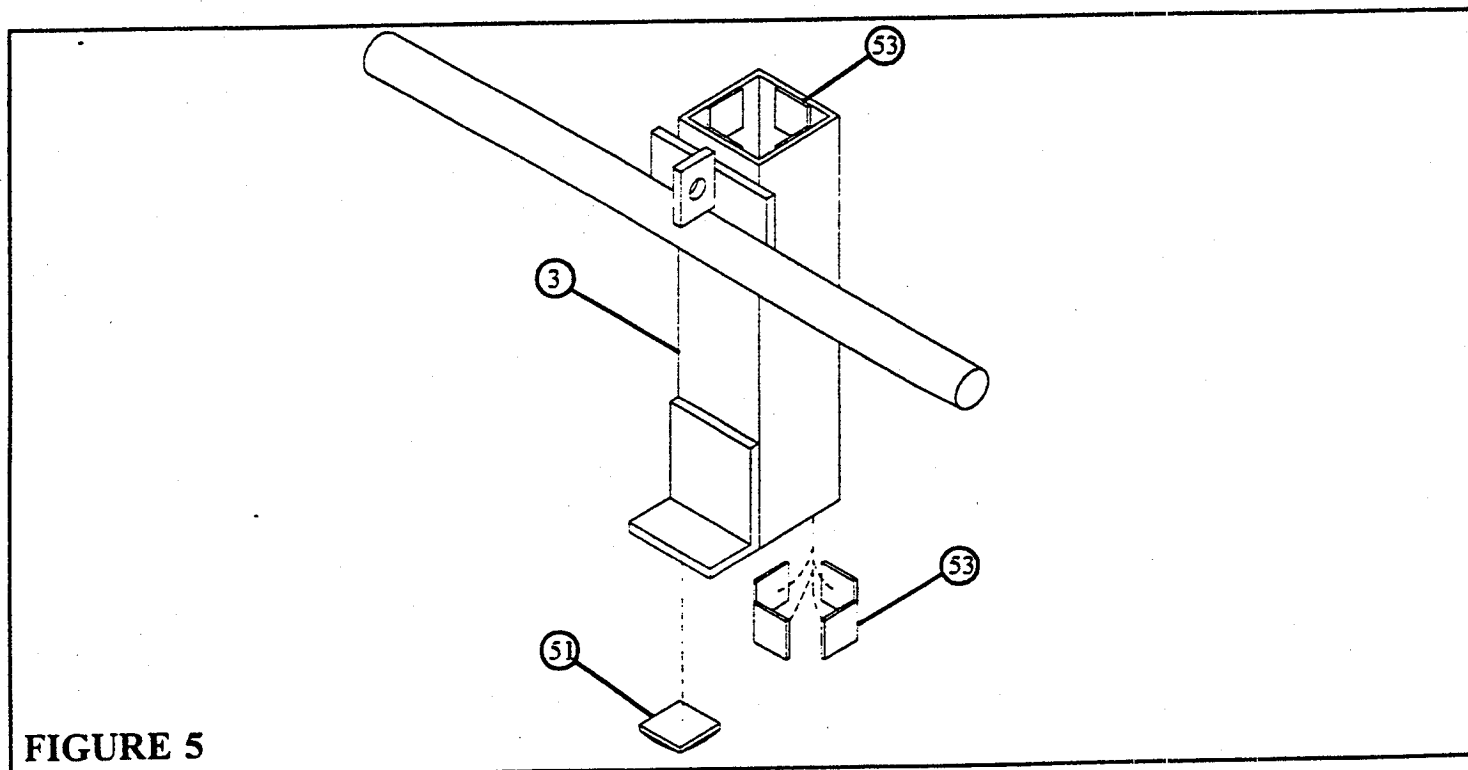
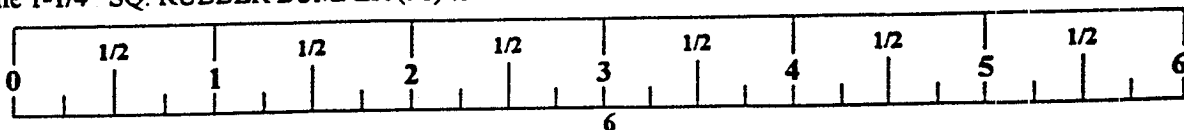

FIGURE 5

STEP 5:

- Apply eight 1" SQ. GLIDES (53) to the inside of the CARRIAGE (3) as shown in FIGURE 5.
- Attach one 1-1/4" SQ. RUBBER BUMPER (51) to the bottom of the CARRIAGE (3) as shown in FIGURE 5.



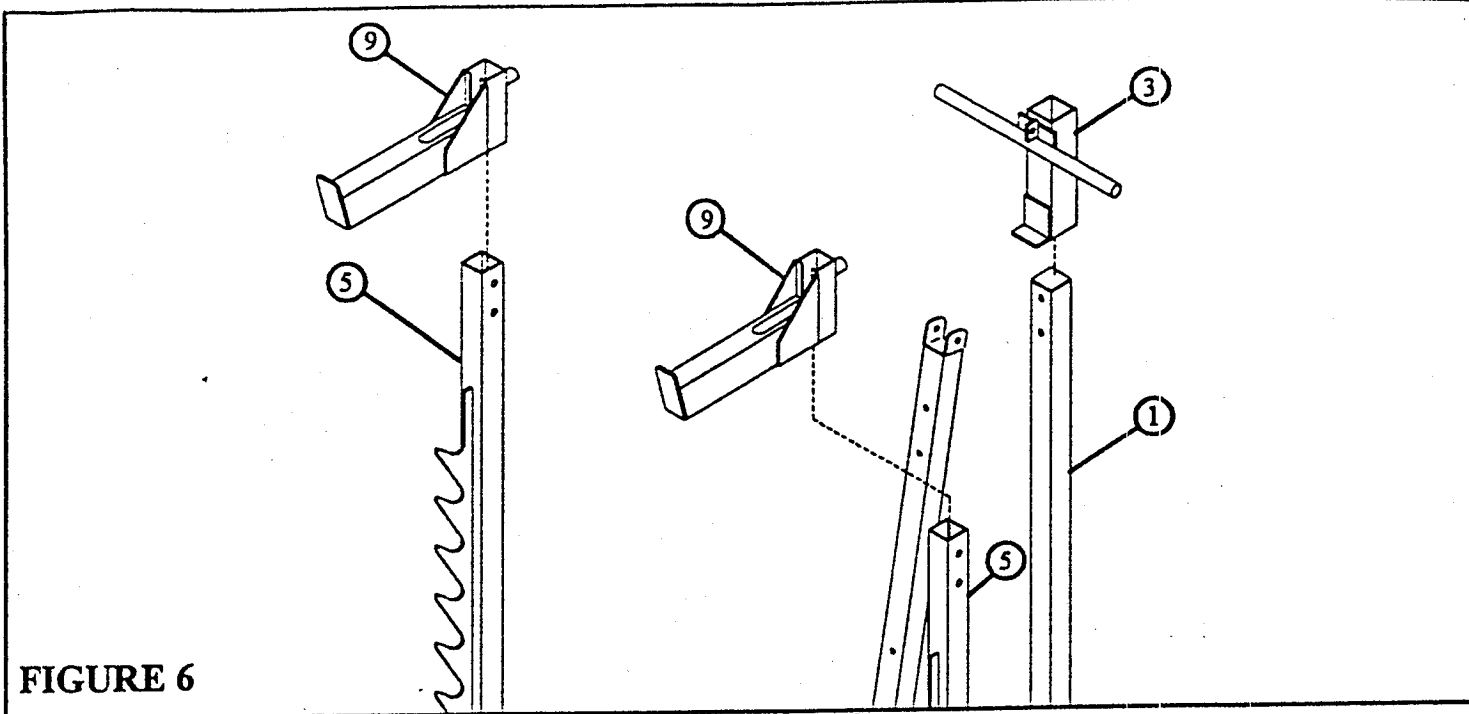

FIGURE 6

STEP 6:

- Pull back the SPRING PIN and slide the SAFETY RAILS (9) over the UPRIGHTS (5) until the SPRING PIN is engaged in the first hole.
- Slide the CARRIAGE (3) over the UPRIGHT FRAME (1) as shown in FIGURE 6.

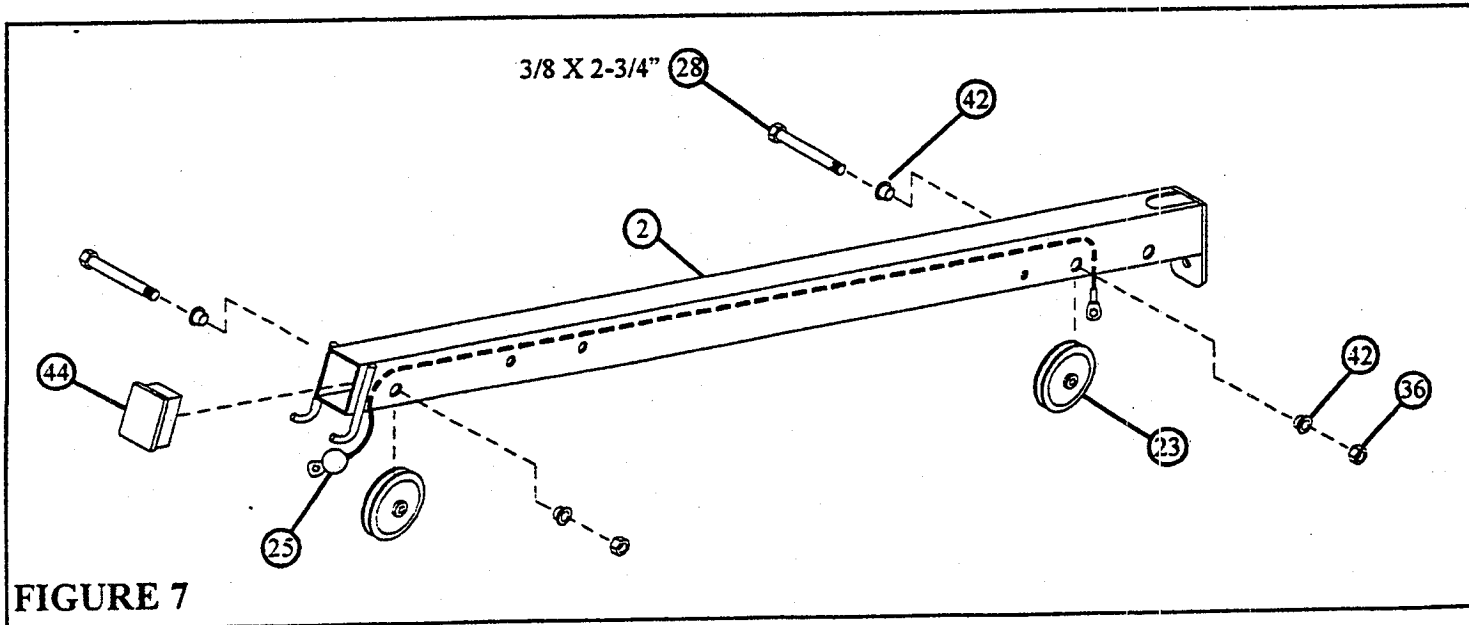

FIGURE 7

STEP 7:

- Insert one 3 X 2" END CAP (44) into the TOP BOOM (2) as shown in FIGURE 7.
- Route end of CABLE (25) (WITHOUT BALL) through the TOP BOOM (2) as shown in FIGURE 7.
- SECURELY assemble two 3-1/2" PULLEYS (23) to the TOP BOOM (2) using two 3/8 X 2-3/4" BOLTS (28), four 3/8" FLANGE SPACERS (42), and two 3/8" LOCKNUTS (36). See FIGURE 7. (NOTE: BEFORE TIGHTENING, MAKE SURE THE CABLE (25) IS IN THE GROOVE OF THE PULLEYS.)

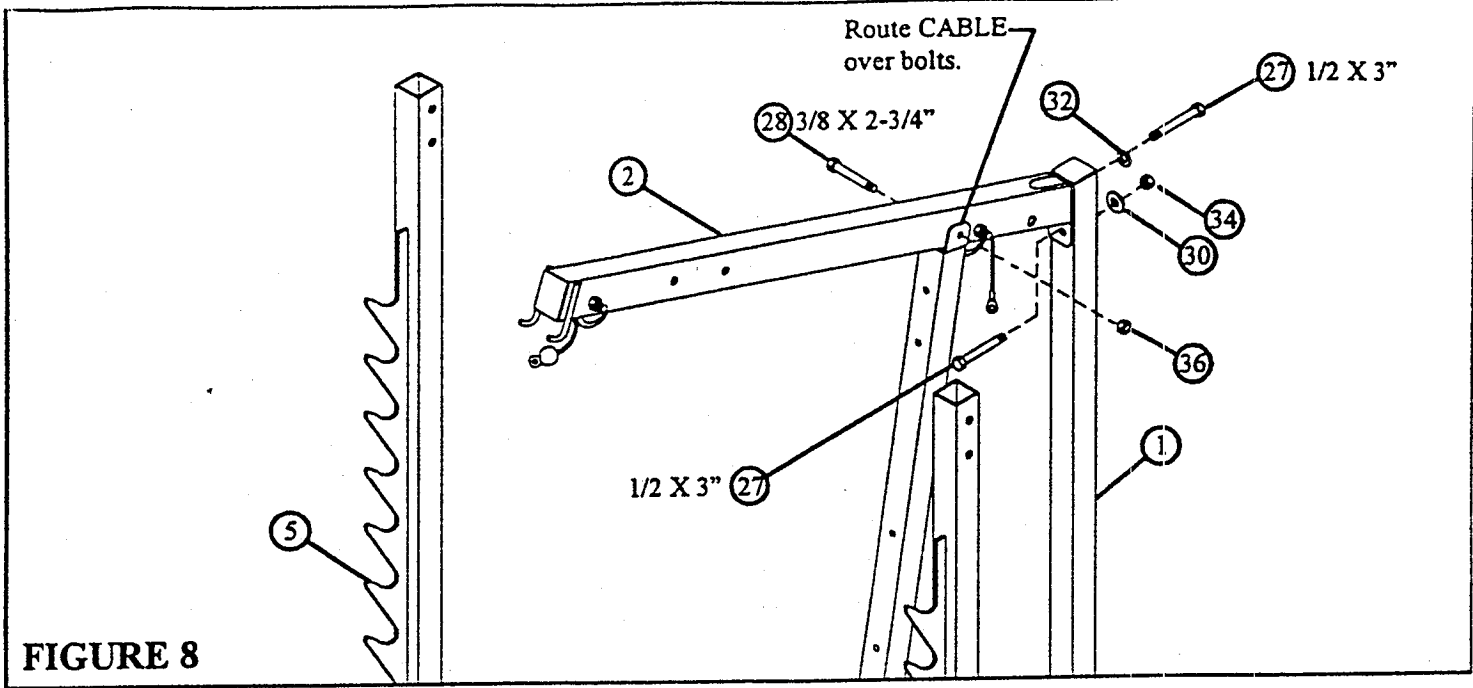

FIGURE 8

STEP 8:

- **LOOSELY** assemble the TOP BOOM (2) to the UPRIGHT FRAME (1) using two 1/2 X 3" BOLTS (27), one 3/8 X 2-3/4" BOLT (28), one 1/2" LOCK WASHER (32), one 1/2" WASHER (30), one 1/2" LOCKNUT (34), and one 3/8" LOCKNUT (36) as shown in FIGURE 8.

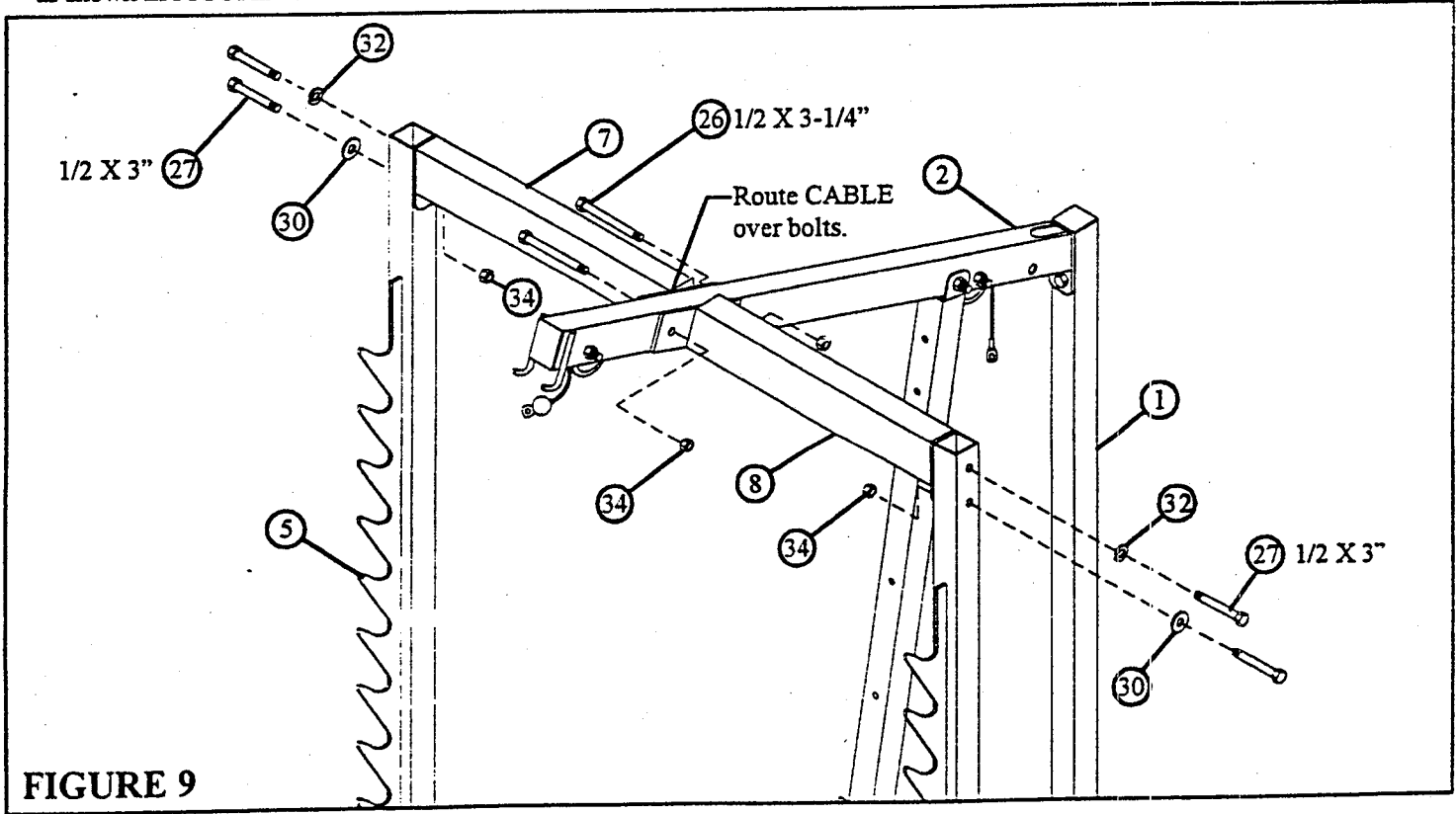
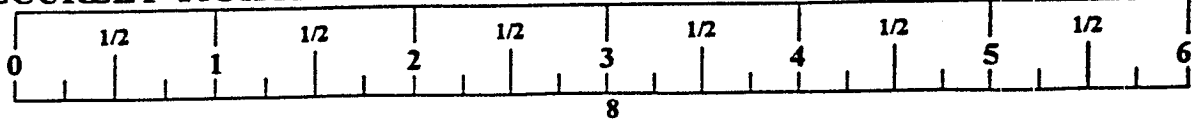

FIGURE 9

STEP 9:

- **LOOSELY** assemble the LEFT (7) & RIGHT (8) BOOM SUPPORTS to the UPRIGHTS (5) and TOP BOOM (2) using four 1/2 X 3" BOLTS (27), two 1/2 X 3-1/4" BOLTS (26), two 1/2" LOCK WASHERS (32), two 1/2" WASHERS (30), and four 1/2" LOCKNUTS (34) as shown in FIGURE 9.

*** SECURELY TIGHTEN ALL LOOSE CONNECTIONS MADE UP TO THIS POINT!**



STEP 10:

- Assemble two 4 X 7" ROLLER PADS (20) to the SWIVEL KNEE SUPPORT (10) using two STARLOCK COLLARS (49) as shown in FIGURE 10.

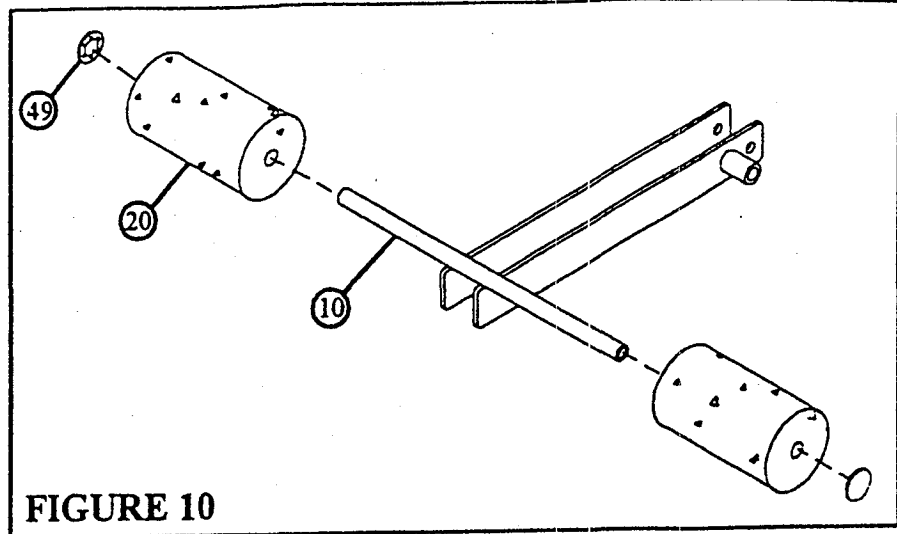

FIGURE 10

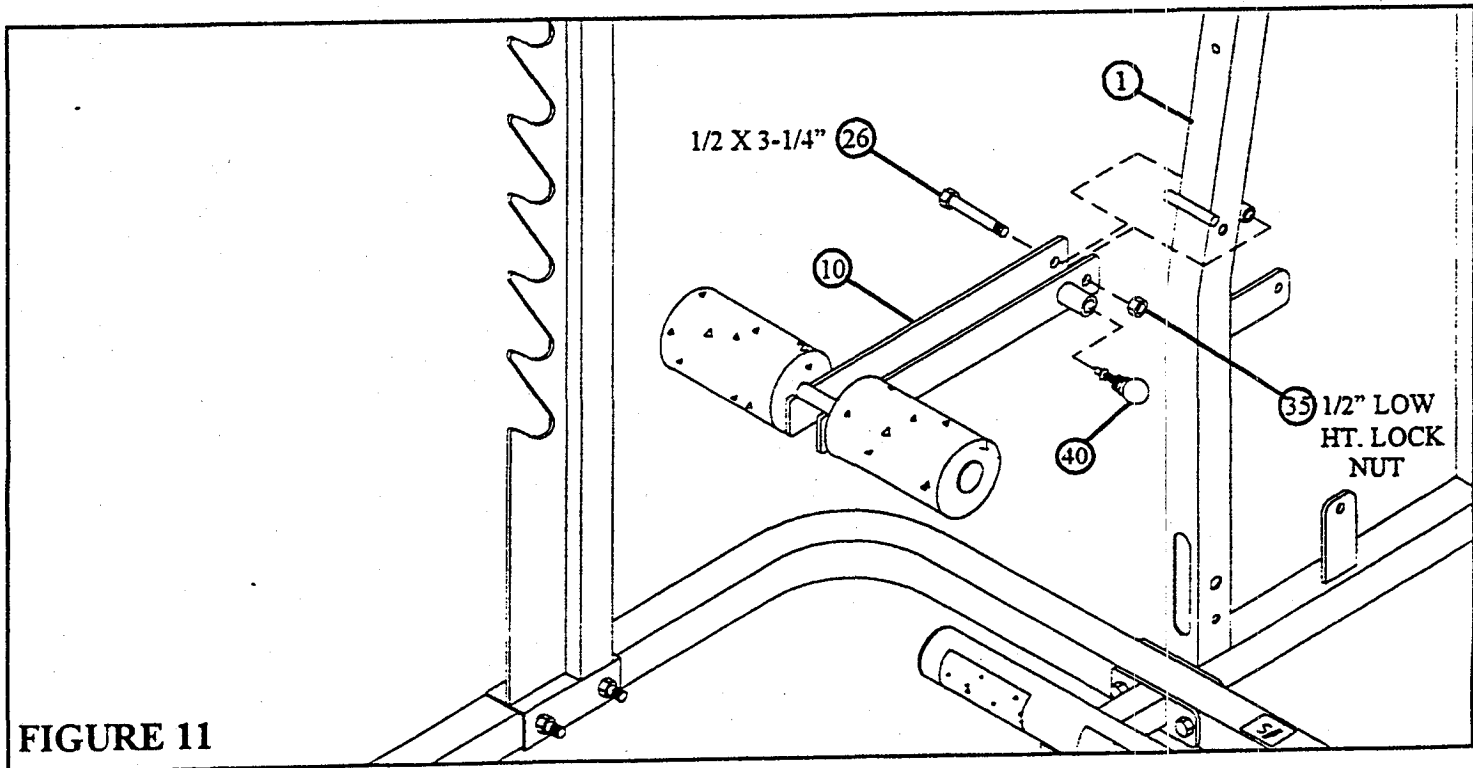

FIGURE 11

STEP 11:

- **SECURELY** assemble the SWIVEL KNEE SUPPORT (10) to the UPRIGHT FRAME (1) using one 1/2 X 3-1/4" BOLT (26) and one 1/2" LOW HT. LOCKNUT (35). (NOTE: Do not overtighten this connection, the SWIVEL KNEE SUPPORT should rotate freely.) See FIGURE 11.
- **SECURELY** assemble the SPRING PIN ASSEMBLY (40) to the SWIVEL KNEE SUPPORT (10) as shown in FIGURE 11.

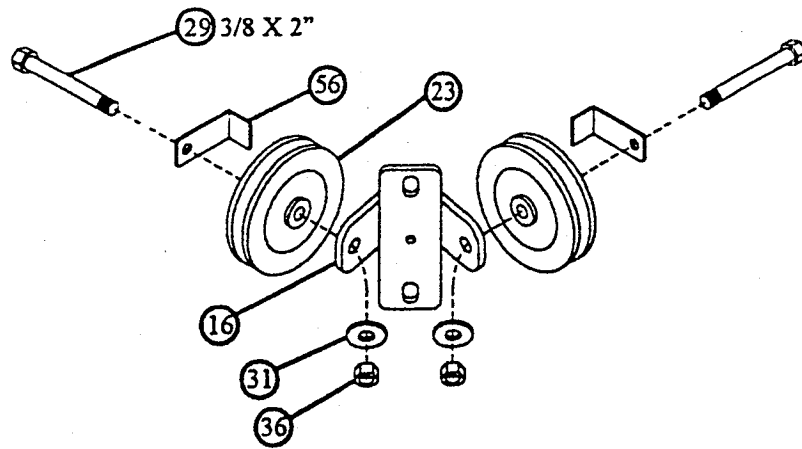

FIGURE 12

STEP 12:

- LOOSELY assemble two 3-1/2" PULLEYS (23) and two CABLE RETAINING CLIPS (56) to the CENTER PULLEY BRACKET (16) using two 3/8 X 2" BOLTS (29), two 3/8" WASHERS (31), and two 3/8" LOCKNUTS (36). See FIGURE 12.

STEP 13:

- Assemble two 2" SQ. END CAPS (47) to the BEARING HOUSING (13) as shown in FIGURE 13.
- Apply two 1" SQ. GLIDES (53) to the plate on the BEARING HOUSING (13) as shown in FIGURE 13.

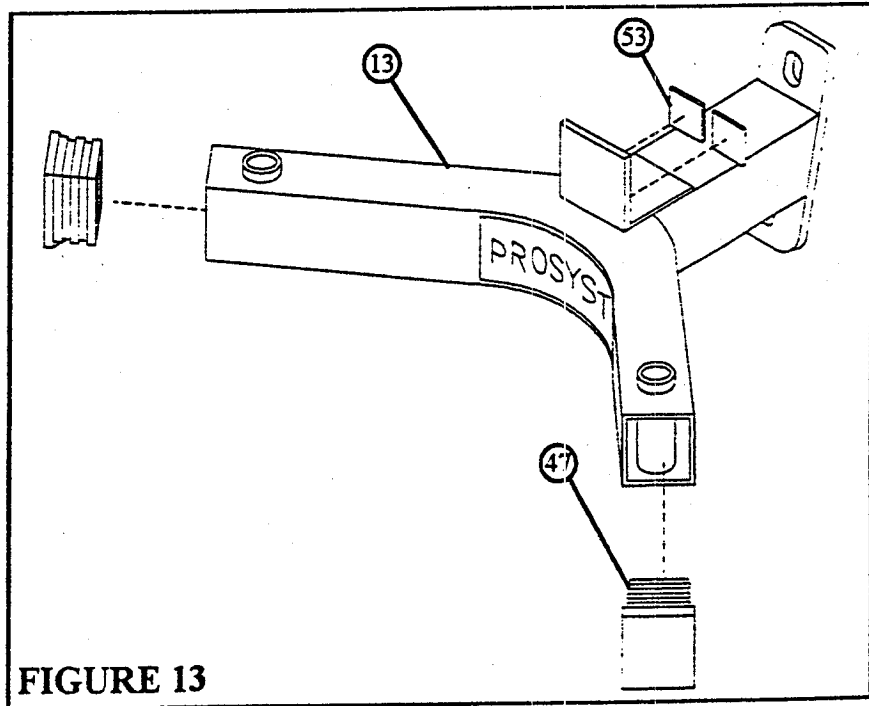
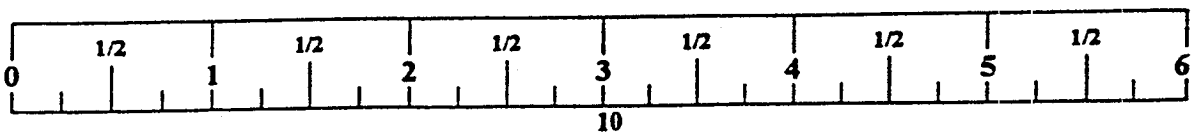

FIGURE 13



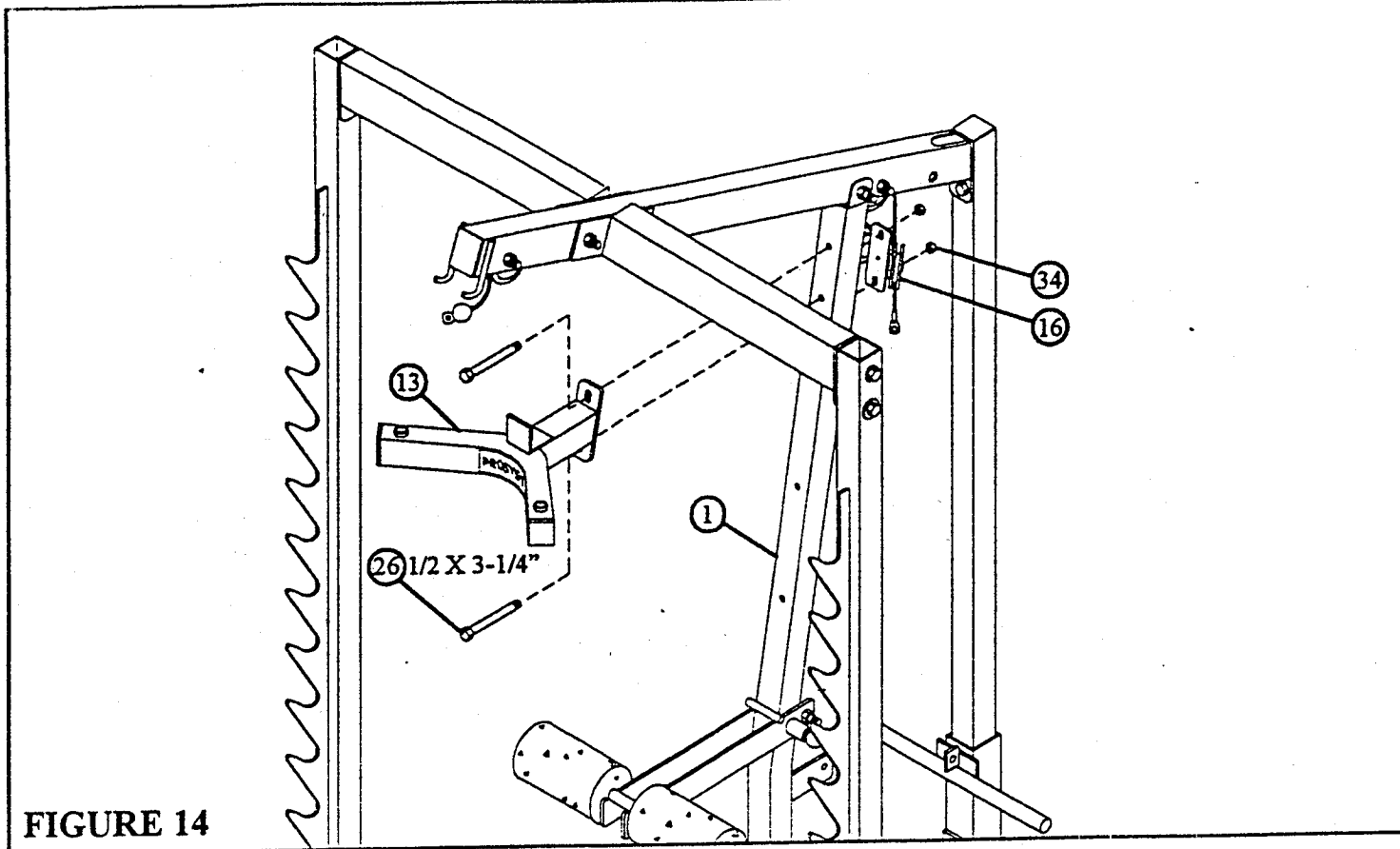

FIGURE 14

STEP 14:

- **SECURELY** assemble the BEARING HOUSING (13) and the CENTER PULLEY BRACKET (16) to the UPRIGHT FRAME (1) using two 1/2 X 3-1/4" BOLTS (26) and two 1/2" LOCKNUTS (34) as shown in FIGURE 14.

STEP 15:

- Insert four 2" SQ. END CAPS (47) into the LEFT (15) & RIGHT (14) PEC ARMS as shown in FIGURE 15.
- Slide two 4 X 12" ROLLER PADS (21) onto the LEFT (15) & RIGHT (14) PEC ARMS as shown in FIGURE 15. (TIP: Spray window cleaner on the inside of the roller pad to help ease assembly.)

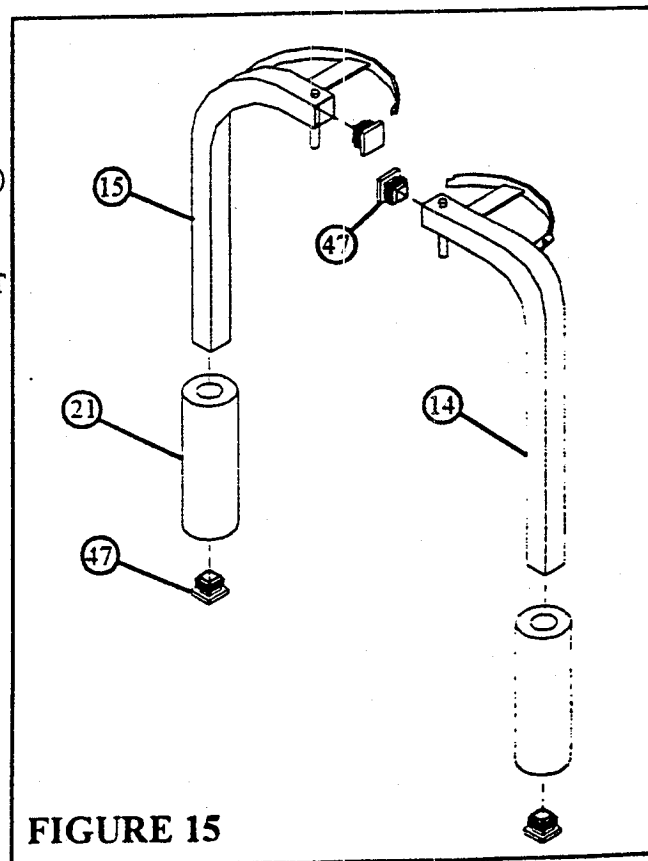

FIGURE 15

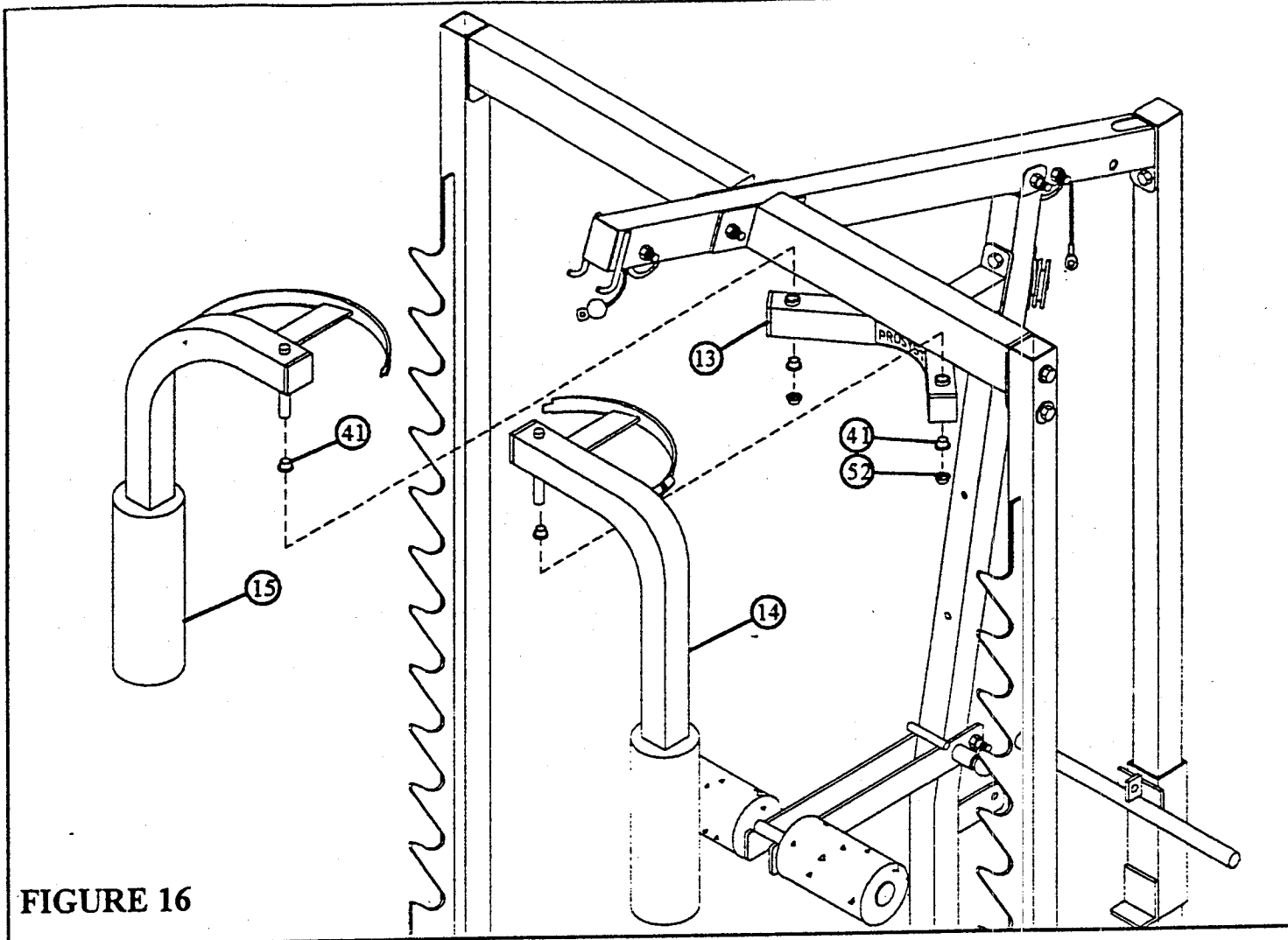

FIGURE 16

STEP 16:

- Assemble the LEFT (15) & RIGHT (14) PEC ARMS to the BEARING HOUSING (13) using four 3/4" FLANGE BEARING (41) and two 3/4" CAP NUTS (52) as shown in FIGURE 16.

STEP 17:

- **SECURELY** assemble BACK PAD (19) to the UPRIGHT FRAME (1) using two 3/8 X 2-3/4" BOLTS (28) and two 3/8" LOCK WASHERS (33) as shown in FIGURE 17.

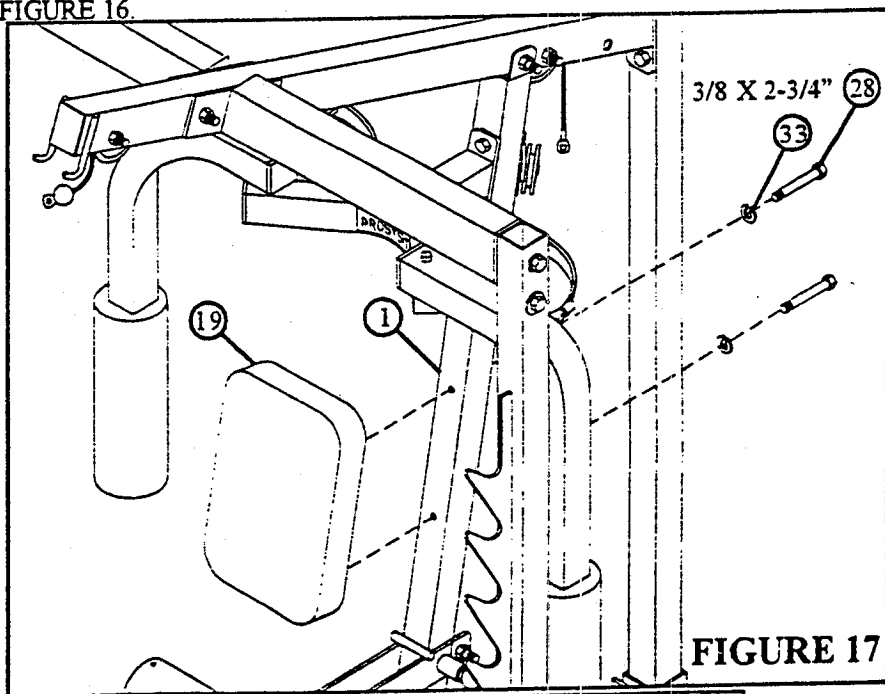
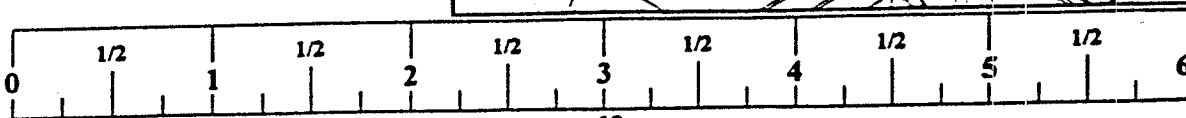
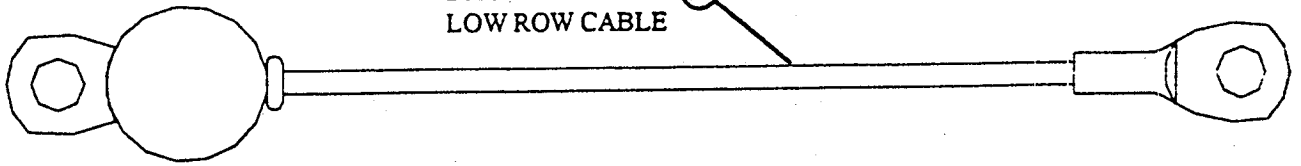

FIGURE 17



LAT CABLE & LOW ROW CABLE (25)



PEC DEC CABLE (24)

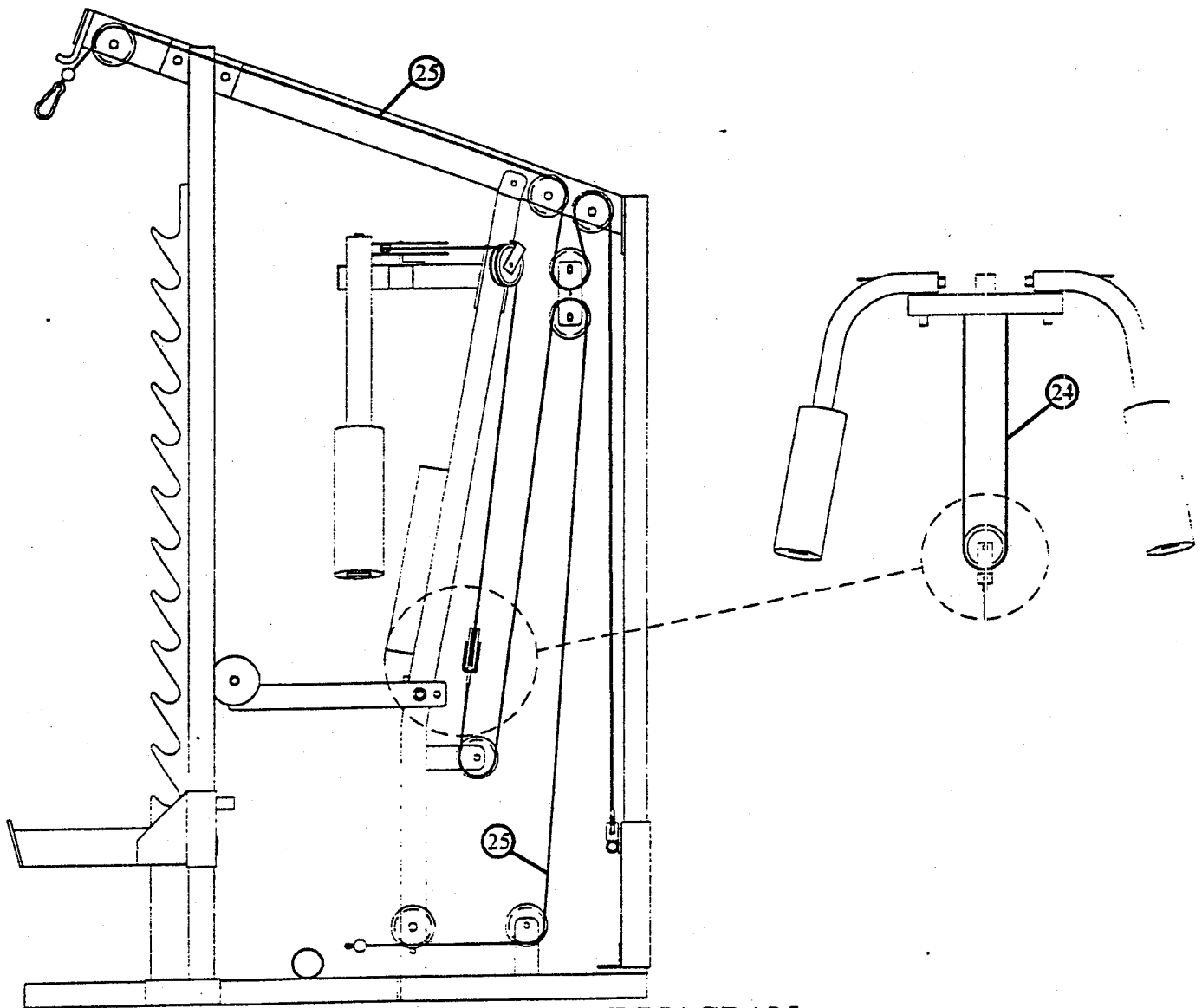
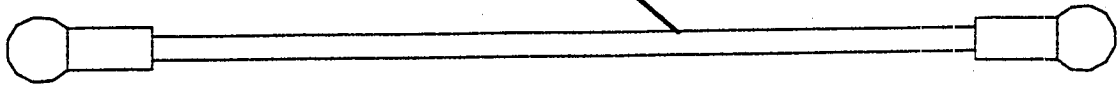

893103 CABLE DIAGRAM

• Refer to the 839103 CABLE DIAGRAM for help with STEPS 17-27

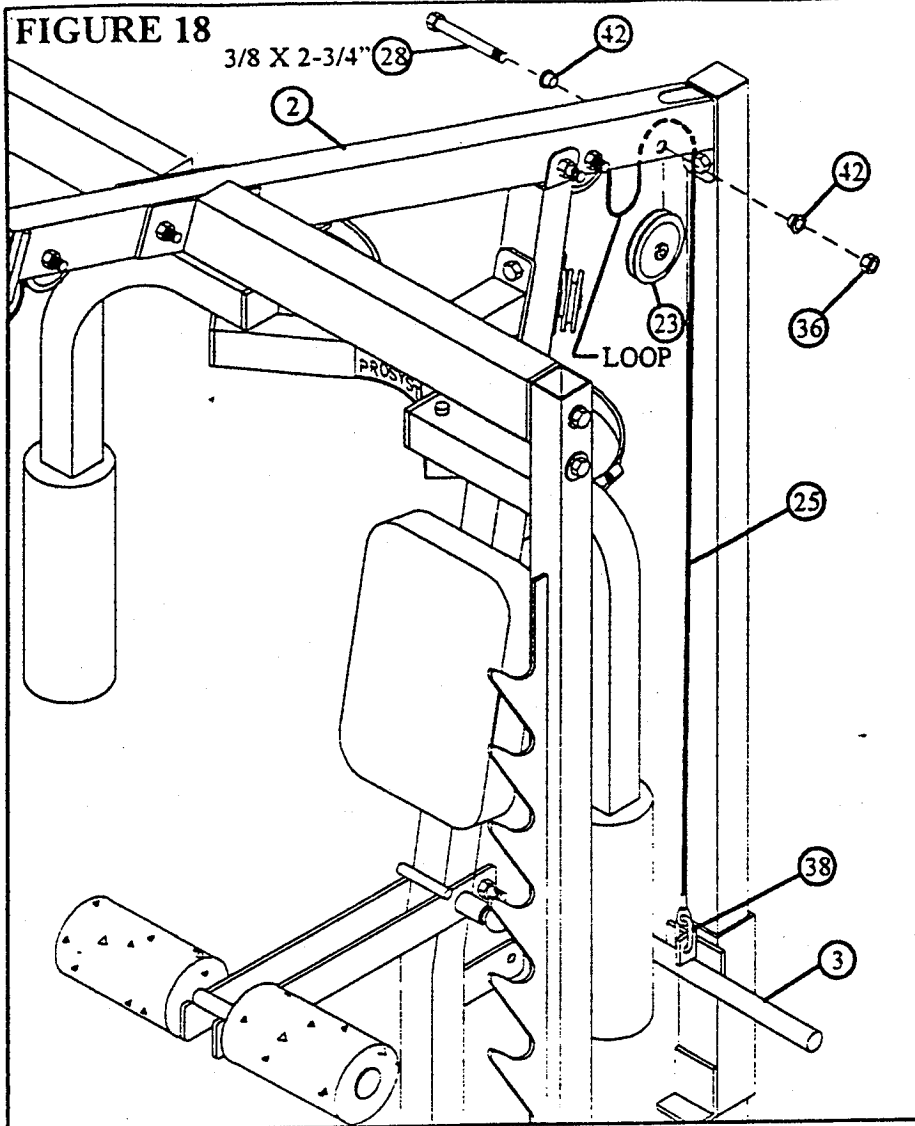
FIGURE 18**STEP 18:**

- Create a loop in the CABLE (25) then wrap the CABLE (25) around the groove of a 3-1/2" PULLEY (23) and SECURELY assemble the PULLEY (23) to the TOP BOOM (2) using one 3/8 X 2-3/4" BOLT (28), two 3/8" FLANGE SPACERS (42), and one 3/8" LOCK NUT (36). See FIGURE 18.
- Attach the CABLE (25) from the TOP BOOM (2) to the CARRIAGE (3) using on QUICK LINK (38) as shown in FIGURE 18.

STEP 19:

- Place one 3-1/2" PULLEY (23) into the loop of the CABLE (25) below the first and second PULLEY of the TOP BOOM (2) as shown in FIGURE 19.
- LOOSELY assemble two 1-3/4 X 5-1/4" PLATES (17) to each side of the PULLEY using one 3/8 X 2" BOLT (29) and one 3/8" LOCKNUT (36). See FIGURE 19.

**FIGURE 19**

FIGURE 20



STEP 20:

- **SECURELY** assemble one 3-1/2" PULLEY (23) and one CABLE RETAINING CLIP (56) to the plate on the UPRIGHT FRAME (1) using one 3/8 X 2" BOLT (29), one 3/8" WASHER (31), and one 3/8" LOCK NUT (36). See FIGURE 20.
- **SECURELY** assemble one 3-1/2" PULLEY (23) into the slot on the UPRIGHT FRAME (1) using one 3/8 X 2-3/4" BOLT (28), two 3/8" FLANGE SPACERS (42), and one 3/8" LOCK NUT (36). See FIGURE 20.

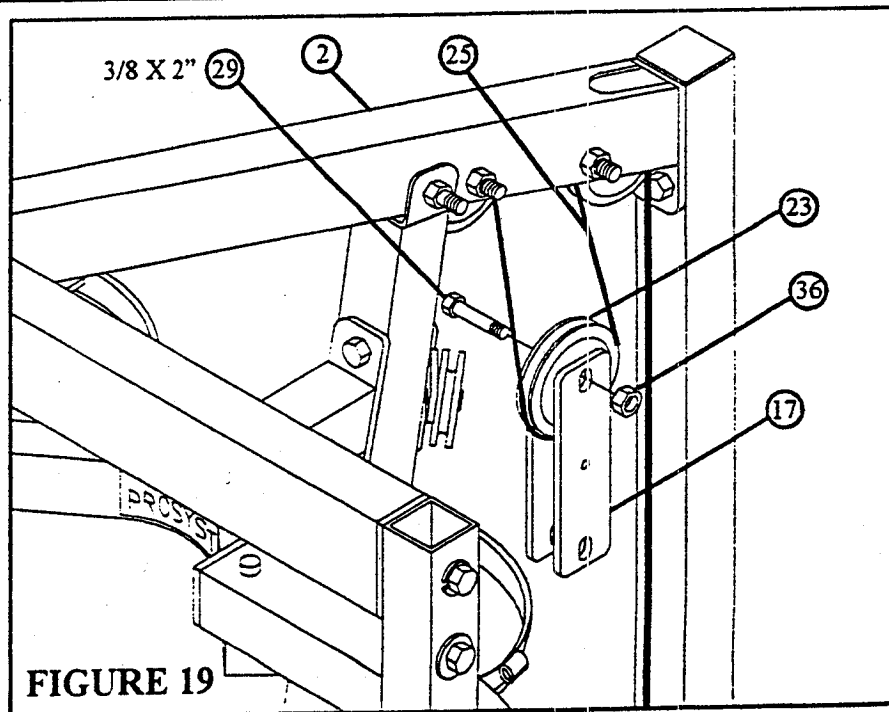
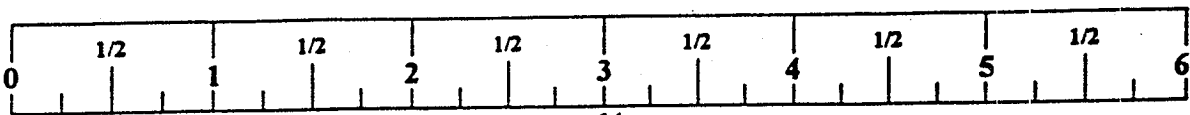
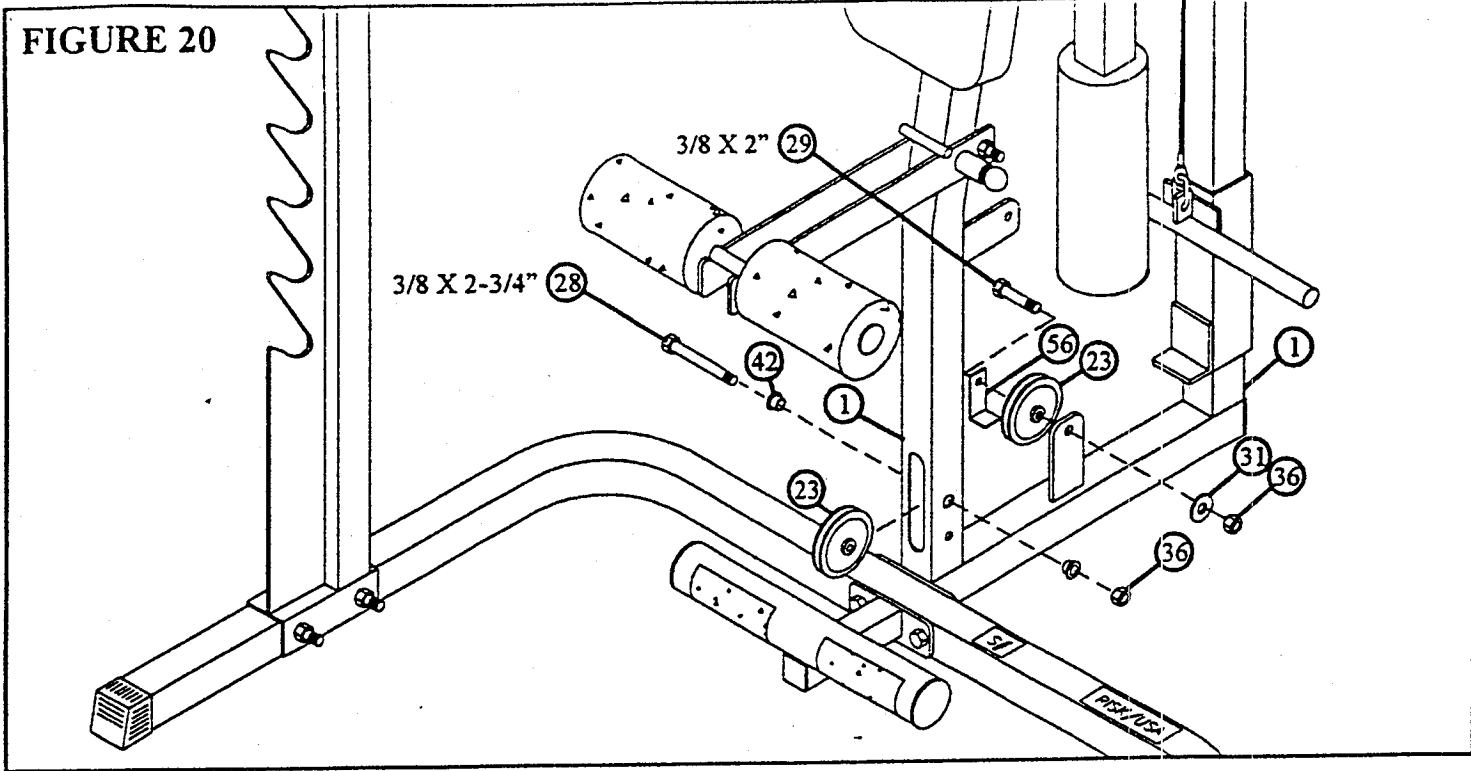
FIGURE 21

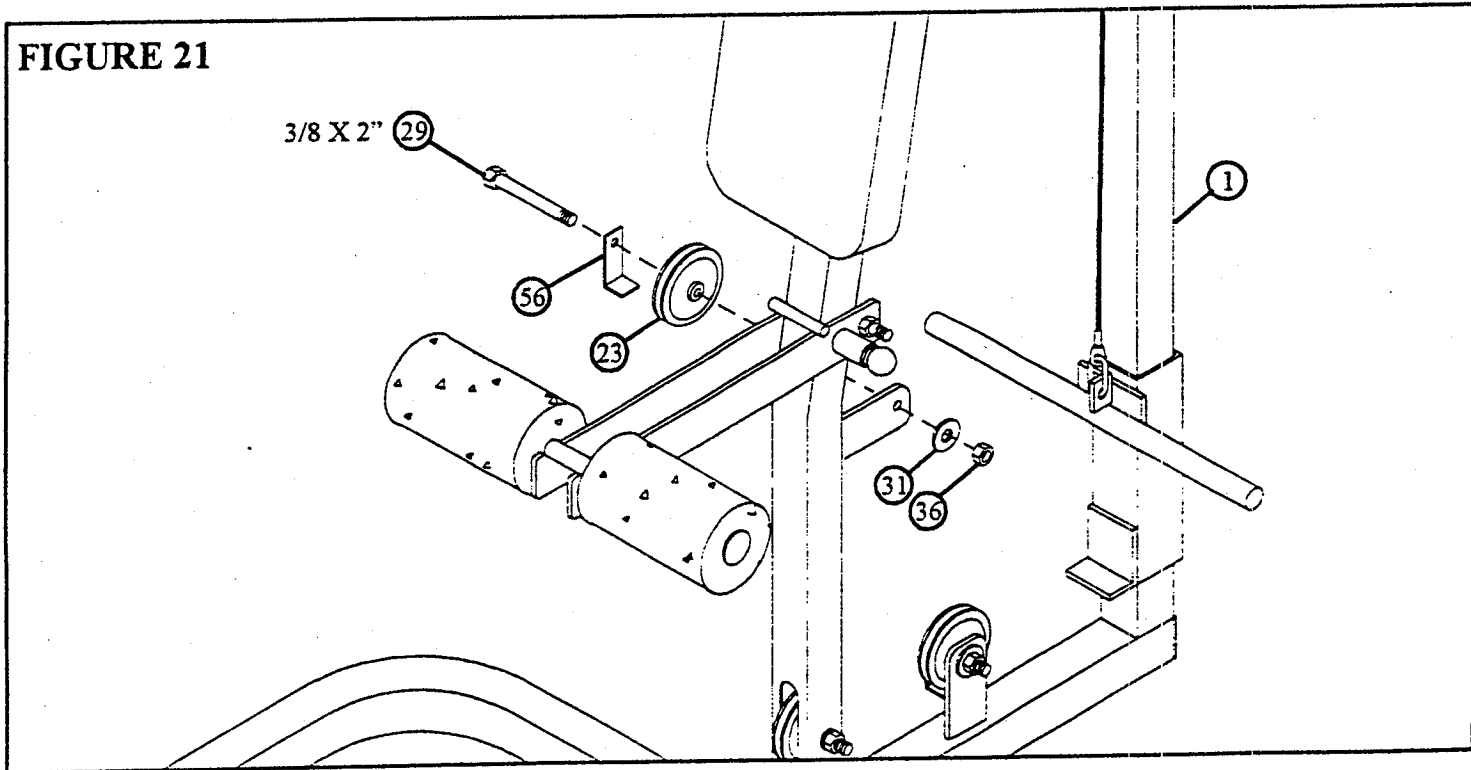

STEP 21:

- **SECURELY** attach one 3-1/2" PULLEY (23) to the plate on the UPRIGHT FRAME (1) using one 3/8 X 2" BOLT (29), one CABLE RETAINING CLIP (56), one 3/8" WASHER (31), and one 3/8" LOCK NUT (36). See FIGURE 21

STEP 22

- Wrap the PEC DEC CABLE (24) around one 3-1/2" PULLEY (23) and assemble the PULLEY to the PULLEY BRACKET (11) using one 3/8 X 2" BOLT (29) and one 3/8" LOCKNUT (36) as shown in FIGURE 22.

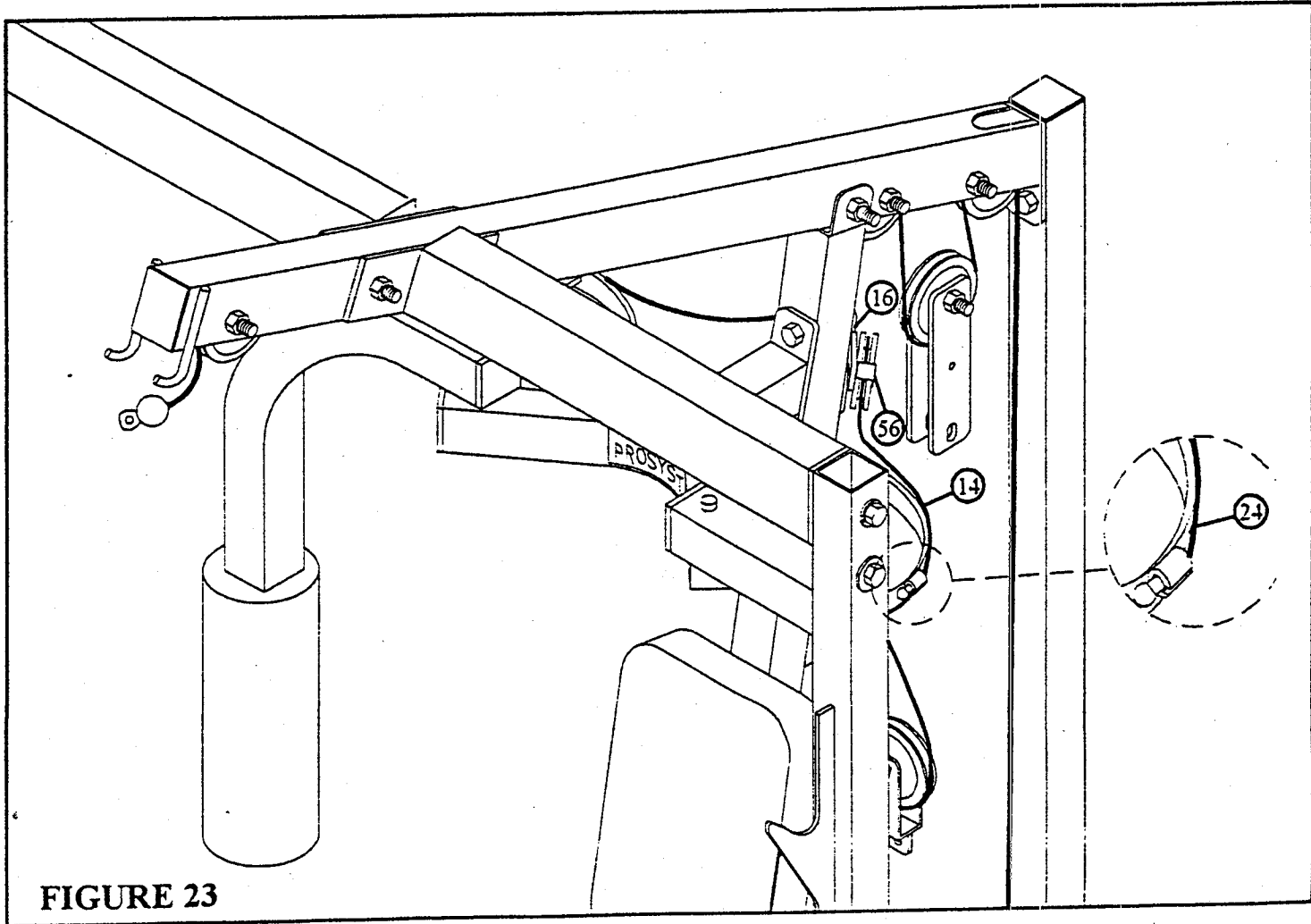
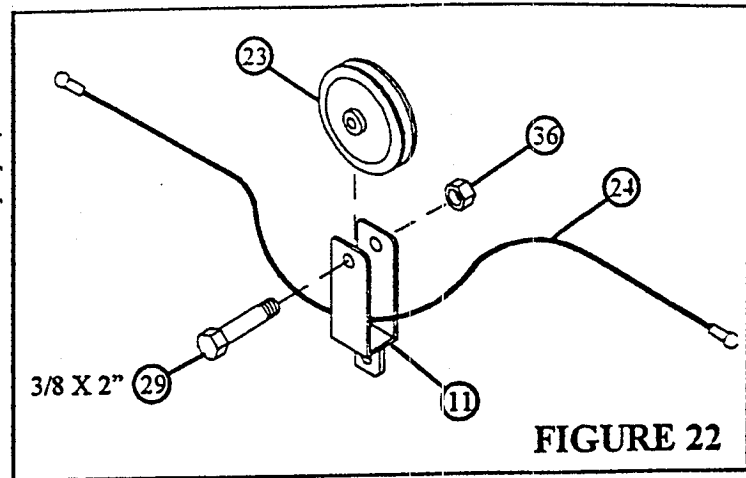

STEP 23:

- Insert each end of PEC CABLE (24) into the bushings on the cams of the LEFT (15) & RIGHT (14) PEC ARMS, then drape the CABLE over the PULLEYS assembled to the CENTER PULLEY BRACKET (16). See FIGURE 23 & 893103 CABLE DIAGRAM on PAGE 12.
- After CABLE (18) has been routed over the PULLEYS on the CENTER PULLEY BRACKET (16), position CABLE RETAINING CLIPS (56) at a 45° angle over the PULLEYS and SECURELY tighten.

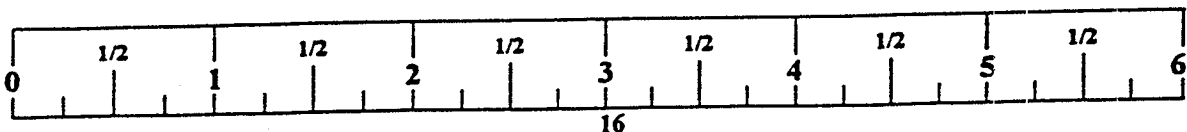

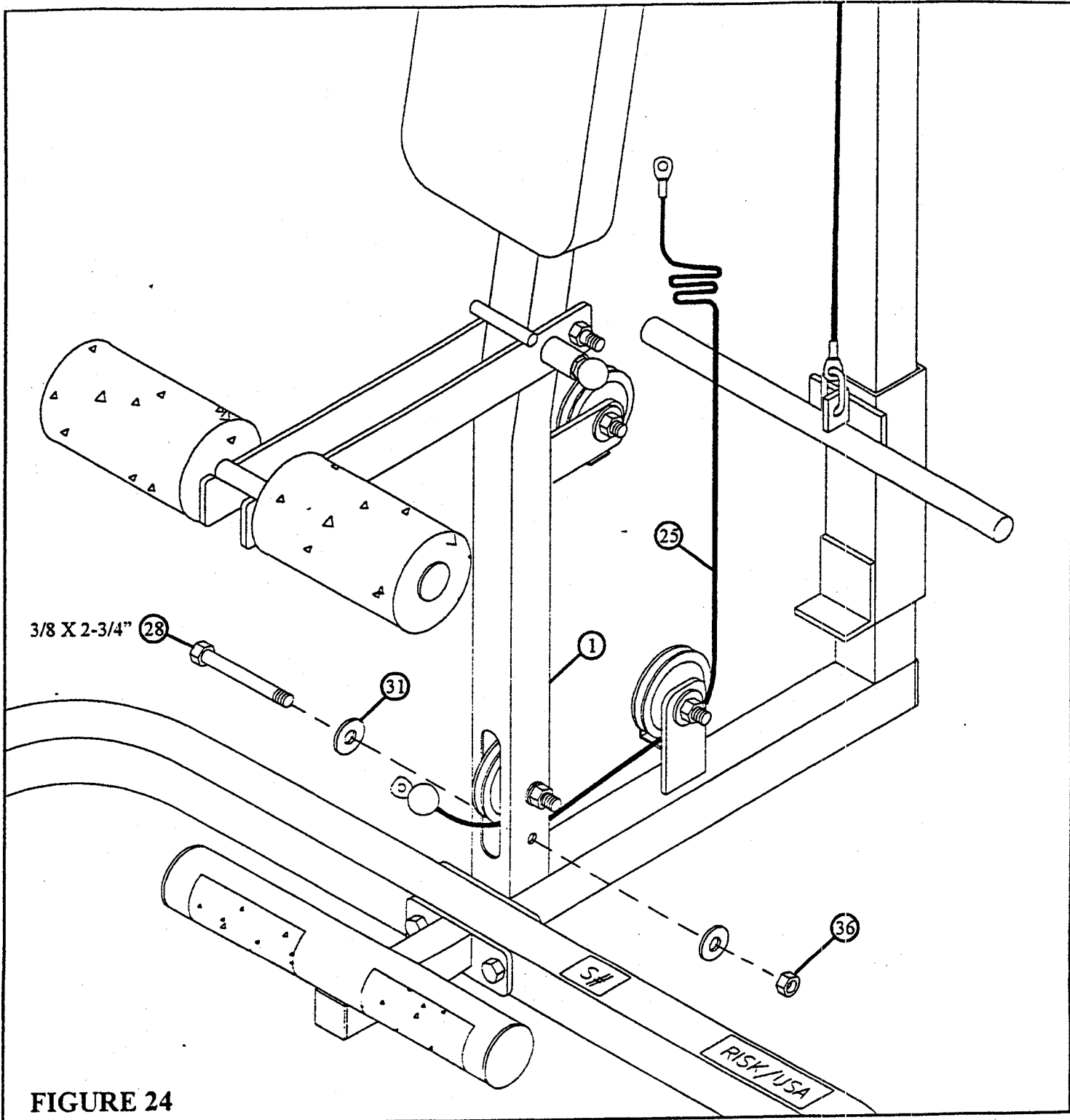

STEP 24:

- Route the CABLE (25) under the 3-1/2" PULLEY in the slot on the FRONT UPRIGHT (1) and around the 3-1/2" PULLEY shown on FIGURE 24. (NOTE: Make sure CABLE (25) is underneath the CABLE RETAINING CLIP.)
- SECURELY assemble one 3/8 X 2-3/4" BOLT (28) to the UPRIGHT FRAME (1) using two 3/8" WASHERS (31), and one 3/8" LOCK NUT (36). (NOTE: Make sure CABLE is between the 3/8 X 2-3/4" BOLT and the 3-1/2" PULLEY.)

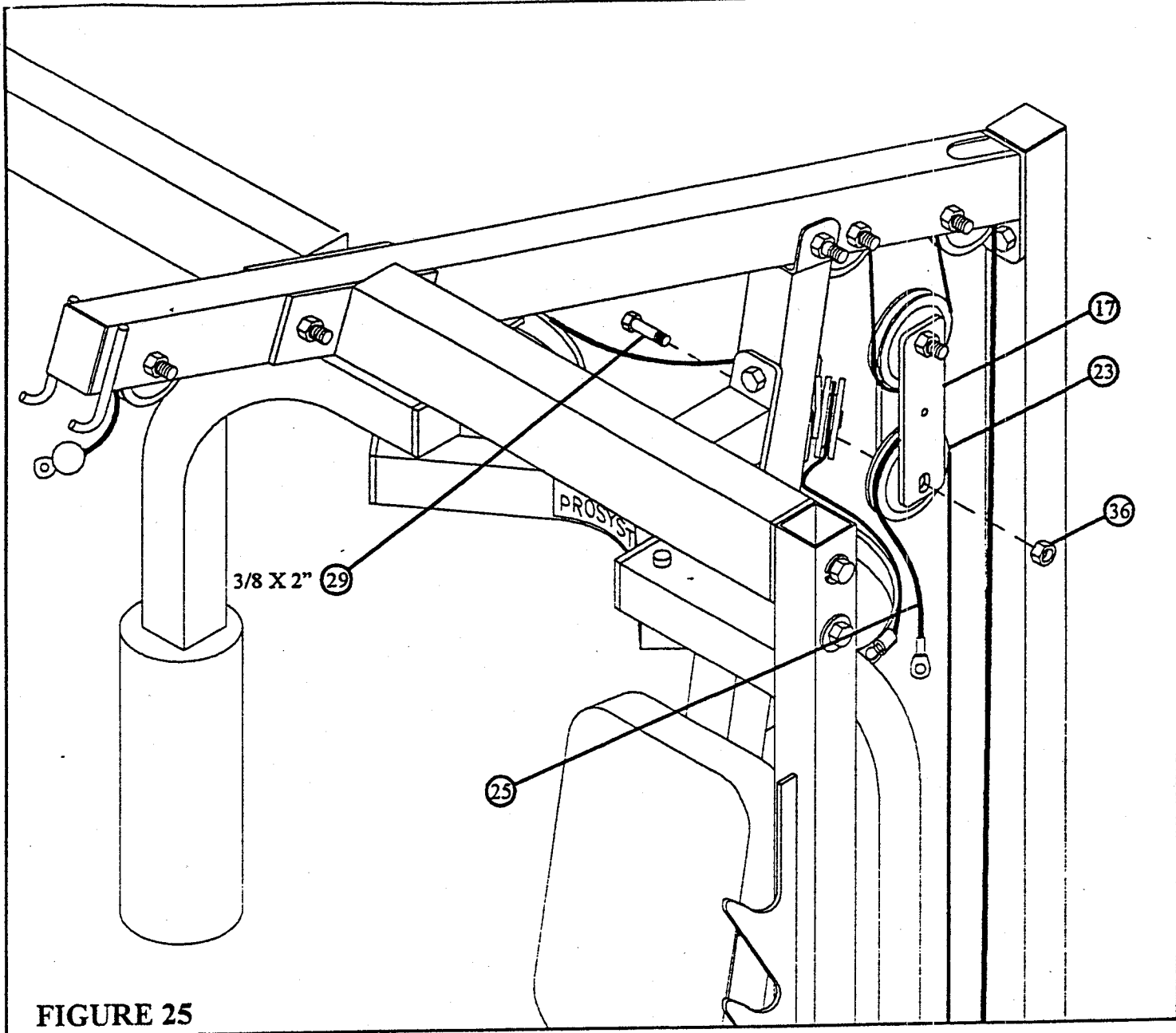
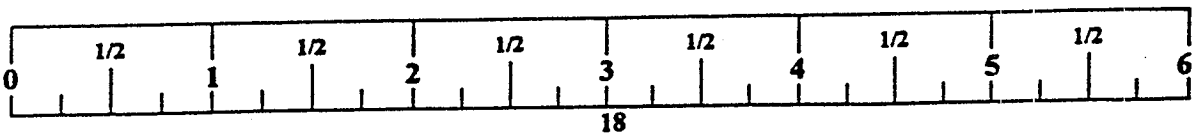

FIGURE 25

STEP 25:

- Loop the **CABLE (25)** around one **3-1/2" PULLEY (23)** and **LOOSELY** assemble **PULLEY** to the **1-3/4 X 5-1/4" PLATES (17)** using one **3/8 X 2" BOLT (29)** and one **3/8" LOCK NUT (36)**. See **FIGURE 25**.



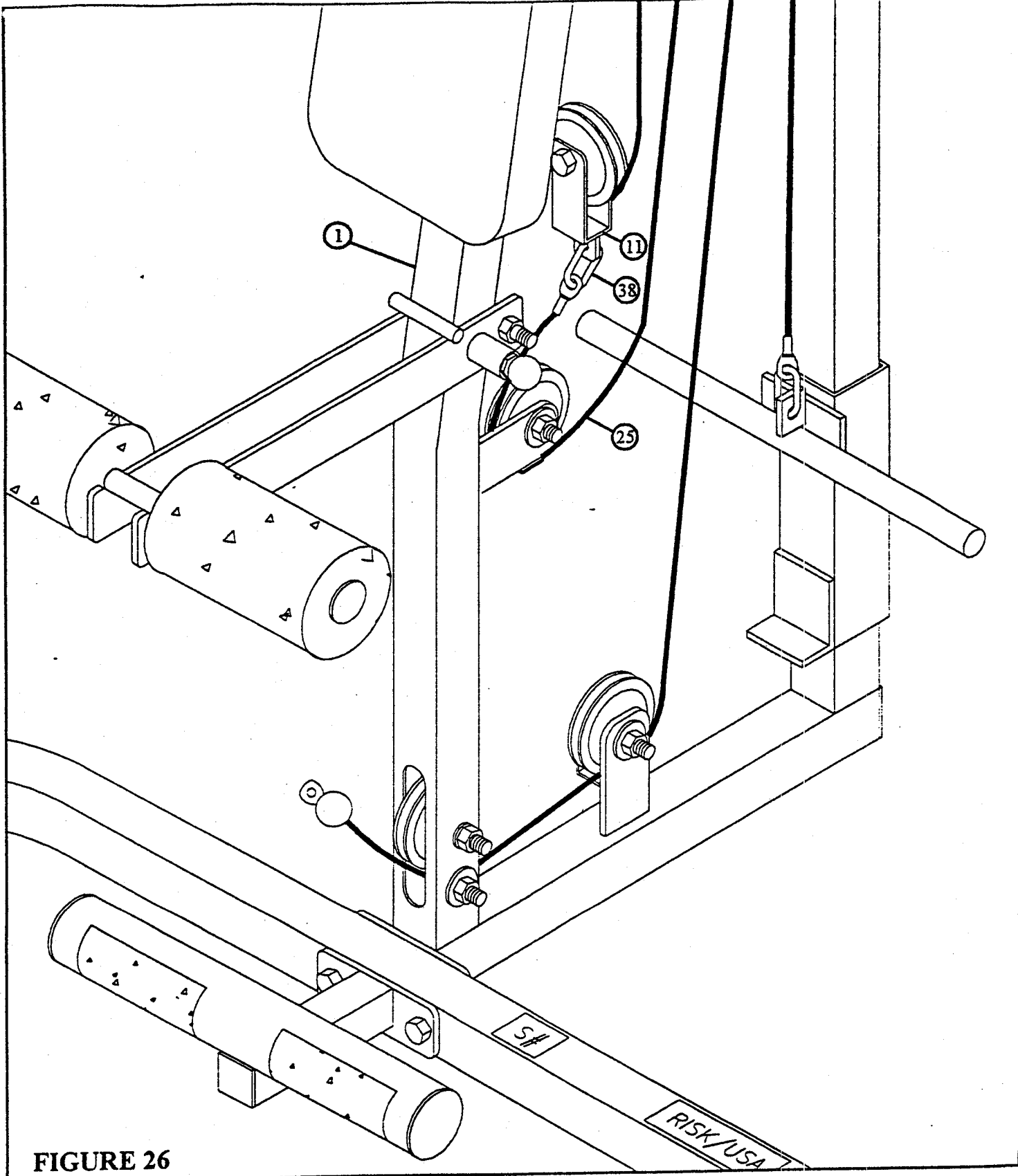

FIGURE 26

STEP 26:

- Route CABLE (25) around PULLEY and under the CABLE RETAINING CLIP on FRONT UPRIGHT (1) as shown in FIGURE 26.
- Attach the CABLE (25) to the PULLEY BRACKET (11) using one QUICK LINK (38) as shown in FIGURE 26.
- **SECURELY** tighten the two PULLEYS assembled between the two 1-3/4 X 5-1/4" PLATES (17).

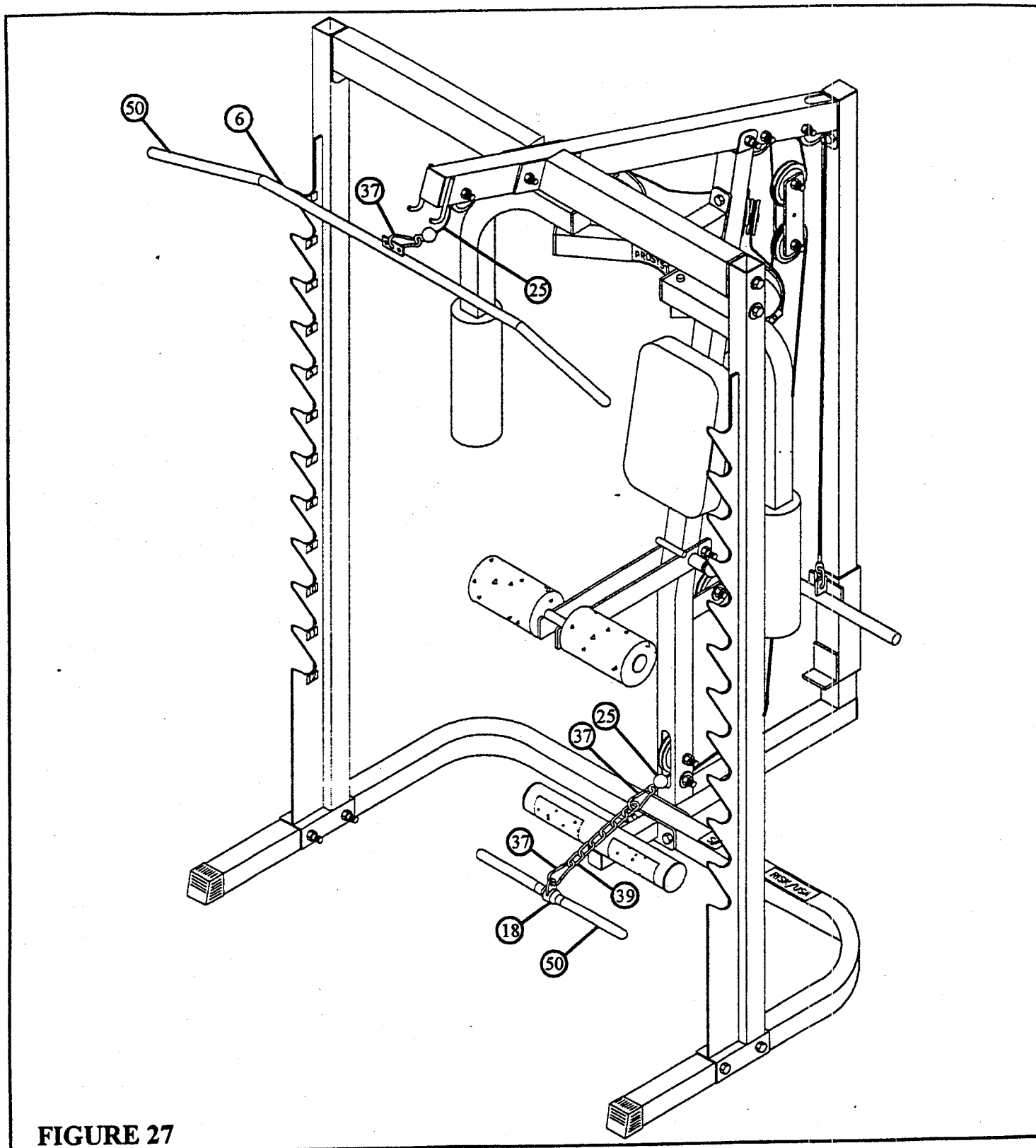

FIGURE 27

STEP 27:

- Attach two 1 X 8" GRIPS (50) to the LAT BAR (6) and two 1 X 8" GRIPS (50) to the LOW ROW BAR (18) as shown in FIGURE 27. (TIP: Spray window cleaner on the inside of the grip to help ease assembly.)
- Attach the LOW ROW BAR (18) to the CABLE (25) using two 5/16" SNAP LINKS (37) and one CHAIN (39) as shown in FIGURE 27.
- Attach the LAT BAR (6) to the CABLE (25) using one 5/16" SNAP LINK (37) as shown in FIGURE 27.

THIS CONCLUDES THE ASSEMBLY OF THE 893103 PRO SYSTEM.