

PARABODY

Serious Steel

888101 SMITH MACHINE

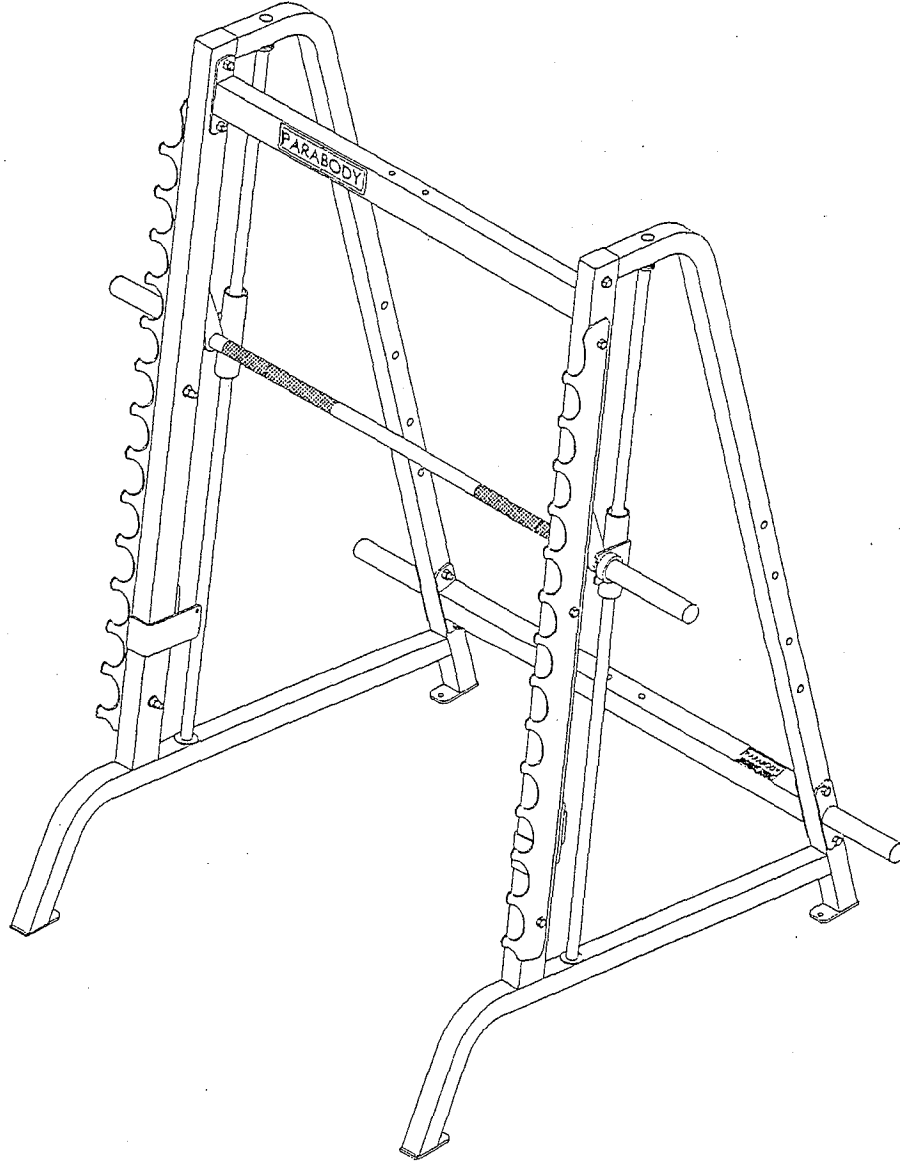

ASSEMBLY INSTRUCTIONS

IMPORTANT NOTES

WELCOME TO THE WORLD OF ***Serious Steel!***

Please note:

* Thank you for purchasing the Parabody 888101 SMITH MACHINE. Please read these instructions thoroughly and keep them for future reference. This product must be assembled on a flat, level surface to assure its proper function.

We recommend cleaning your product (pads and frame) on a regular basis, using warm soapy water. Touch-up paint can be purchased from your Parabody customer service representative at (800) 328-9714.

There is a risk assumed by individuals who use this type of equipment. To minimize risk, please follow these rules:

1. Inspect equipment daily. Tighten all loose connections and replace worn parts immediately. Failure to do so may result in serious injury.
2. Do not allow minors or children to play on or around this equipment.
3. Exercise with care to avoid injury.
4. If unsure of proper use of equipment, call your local Parabody distributor or call the Parabody customer service department at (800) 328-9714.
5. Consult a physician before beginning any exercise program.

Tools Required for Assembly

- * 3/4" wrench
- * 9/16" wrench
- * Ratchet with 3/4" and 9/16" sockets
- * 7/32" Allen wrench
- * Adjustable wrench
- * Tape measure

Bolt Length Ruler

NOTE: BOLT LENGTH IS MEASURED FROM THE UNDERSIDE OF THE HEAD OF THE BOLT.

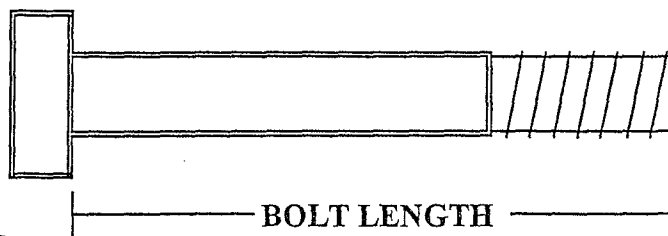

BOLT LENGTH RULER:

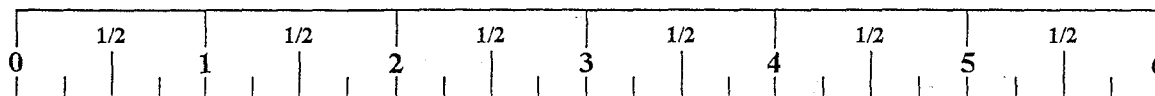

PARTS LIST

KEY	PART#	DESCRIPTION	QTY	KEY	PART#	DESCRIPTION	QTY
1	6798103	UPPER CROSS BRACE	1	12	6692601	3 X 2" END CAP	2
2	6798103	LOWER CROSS BRACE	1	13	3102910	1/2 X 3 BCLT	12
3	6798502	SAFETY STOP LEFT	1	14	3102502	1/2" WASHER	6
4	6798402	SAFETY STOP RIGHT	1	15	3102801	1/2" LOCK NUT	12
5	6799702	SMITH BAR	1	16	3105302	7/16" HOLE PLUG	8
6	6798901	HOUSING	2	17	3105303	9/16" HOLE PLUG	16
7	6799601	PLATE HOLDER	2	18	6824601	3-1/4 X 1-3/4" GLIDE	6
8	6799203	UPRIGHT FRAME	2	19	6695801	2 1/2" OD RUBBER BUMPER	2
9	6799801	72" GUIDE ROD	2	20	3109302	1-3/4" ROUND END CAP	4
10	6714901	GUIDEROD BUSHING	4	21	6807101	GUNRACK	2
11	3203002	1" SHAFT COLLAR	2				

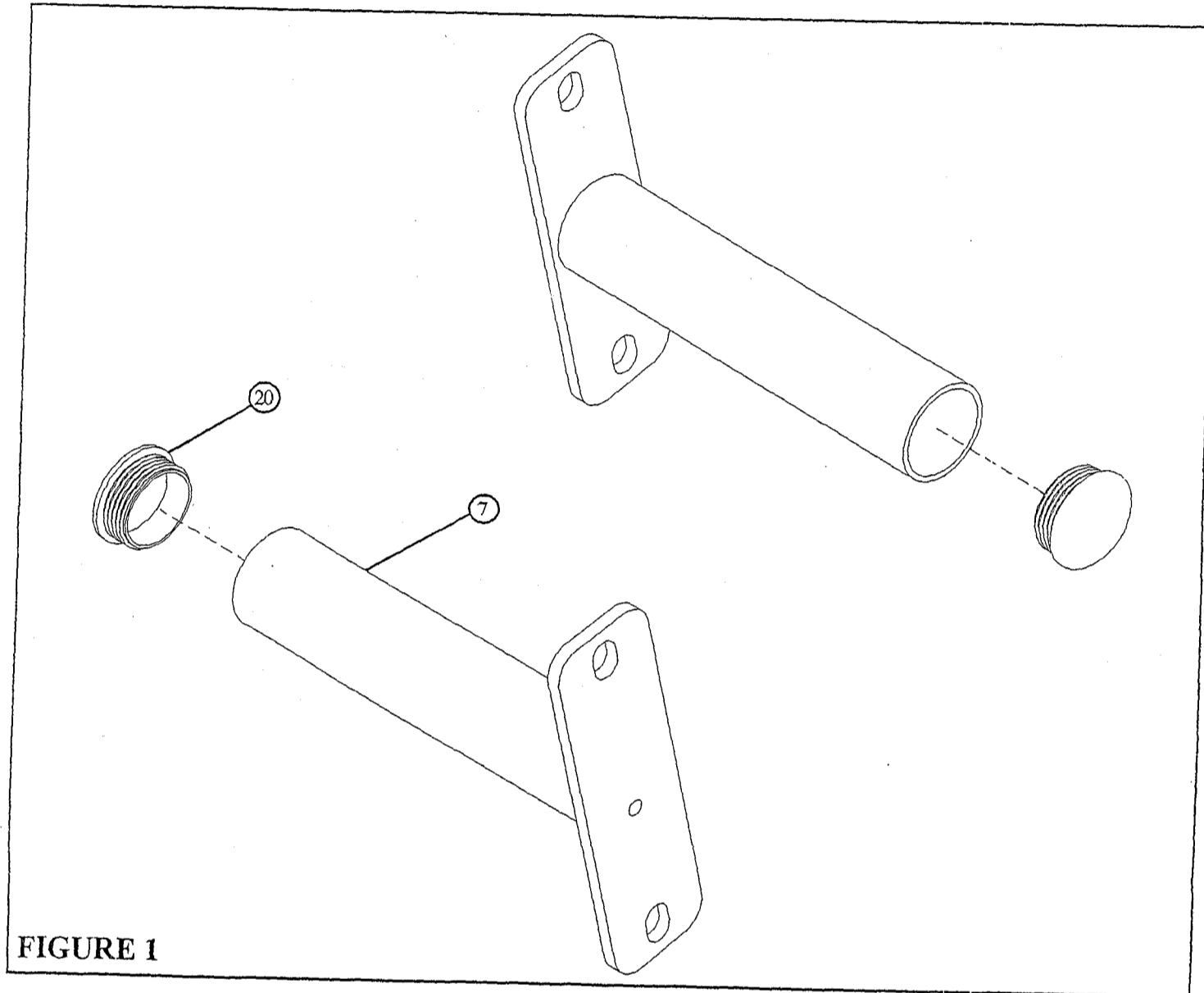

STEP 1:

- Insert two 1-3/4" ROUND END CAPS (20) into the end of the PLATE HOLDERS (7) as shown in FIGURE 1.

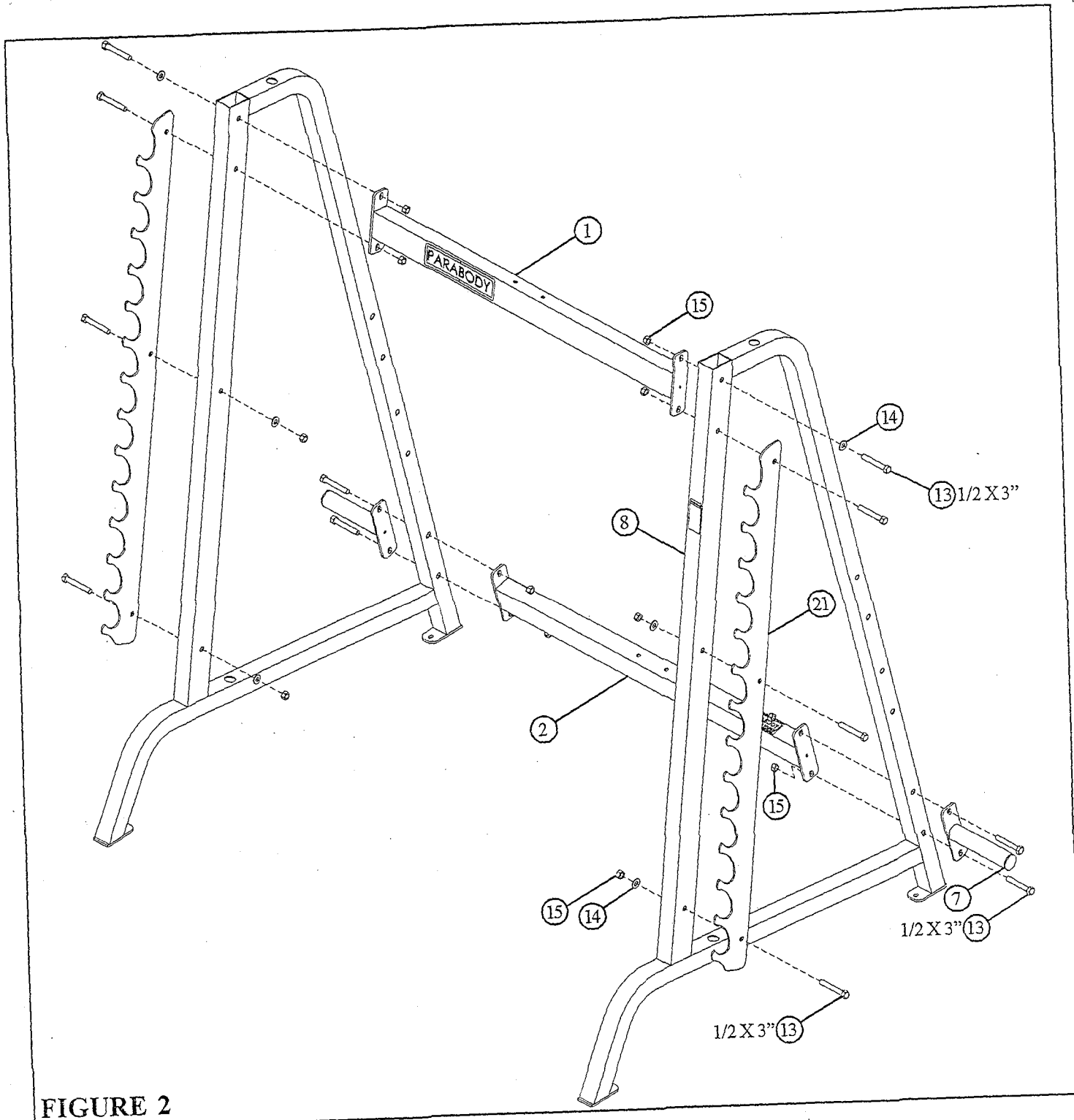
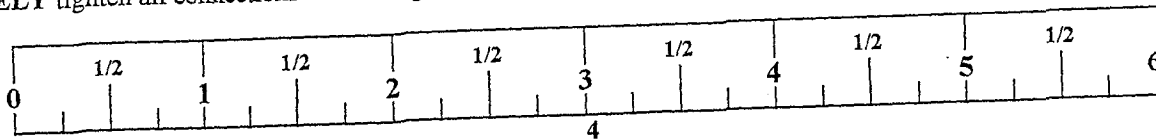

FIGURE 2

STEP 2:

- **LOOSELY** assemble the PLATE HOLDERS (7) and the LOWER CROSS SUPPORT (2) to the UPRIGHT FRAMES (8) as shown in FIGURE 2 using four 1/2 X 3" BOLTS (13), and four 1/2" LOCK NUTS (15).
- **LOOSELY** assemble the UPPER CROSS SUPPORT (1) to the top set of holes of the UPRIGHT FRAMES (8) as shown in FIGURE 2 using two 1/2 X 3" BOLTS (13), two 1/2" WASHERS (14), and two 1/2" LOCK NUTS (15).
- **LOOSELY** assemble the GUN RACKS (21) to the outside of the UPRIGHT FRAMES (8) as shown in FIGURE 2 using six 1/2 X 3" BOLTS (13), four 1/2" WASHERS (14), and six 1/2" LOCK NUTS (15).
- **SECURELY** tighten all connections made to up to this point.



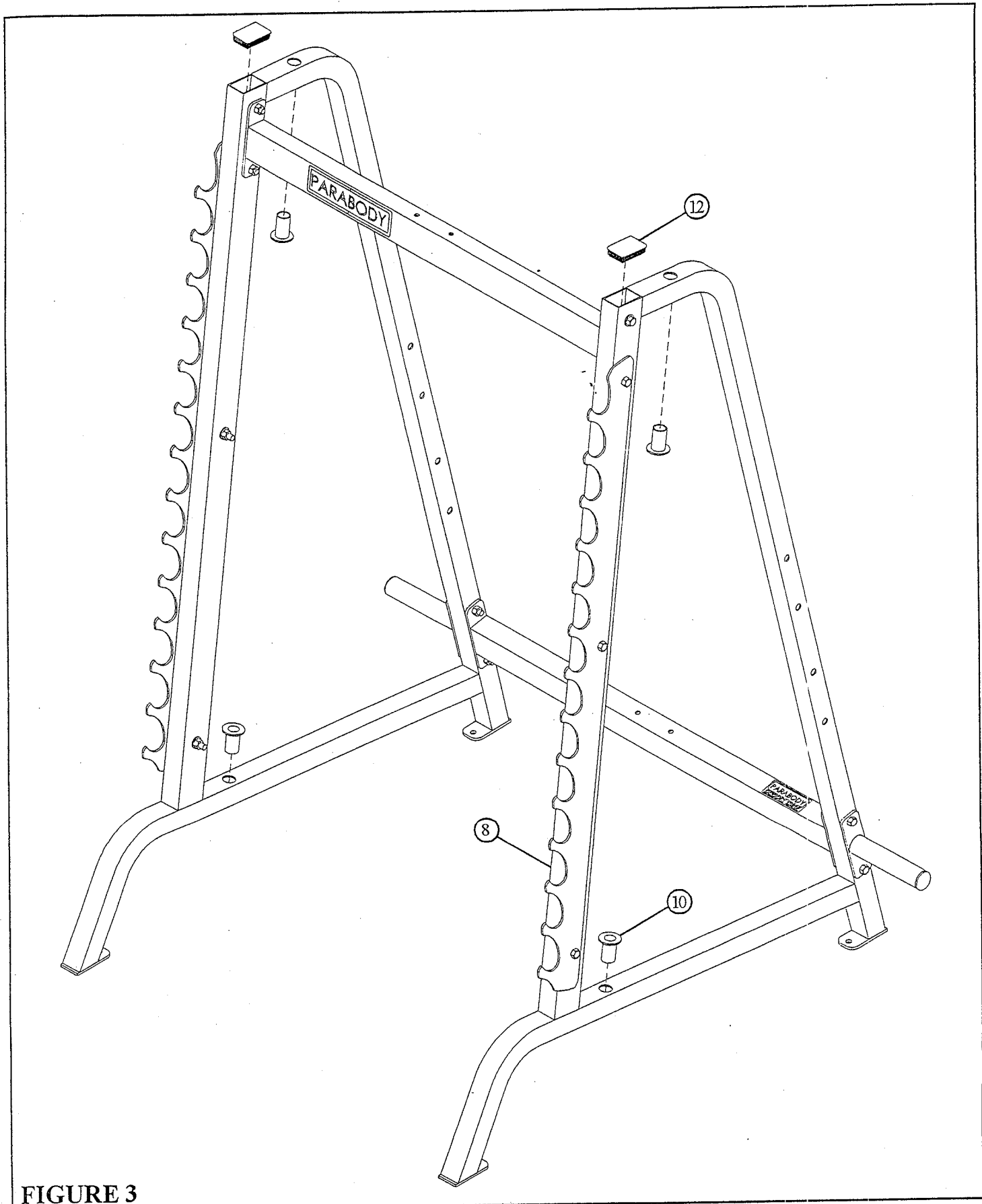

FIGURE 3

STEP 3:

- Insert two 3 X 2" END CAPS (12) into the ends of the UPRIGHT FRAMES (8) as shown in FIGURE 3.
- Insert four GUIDE ROD BUSHINGS (10) into the UPRIGHT FRAMES (8) as shown in FIGURE 3.

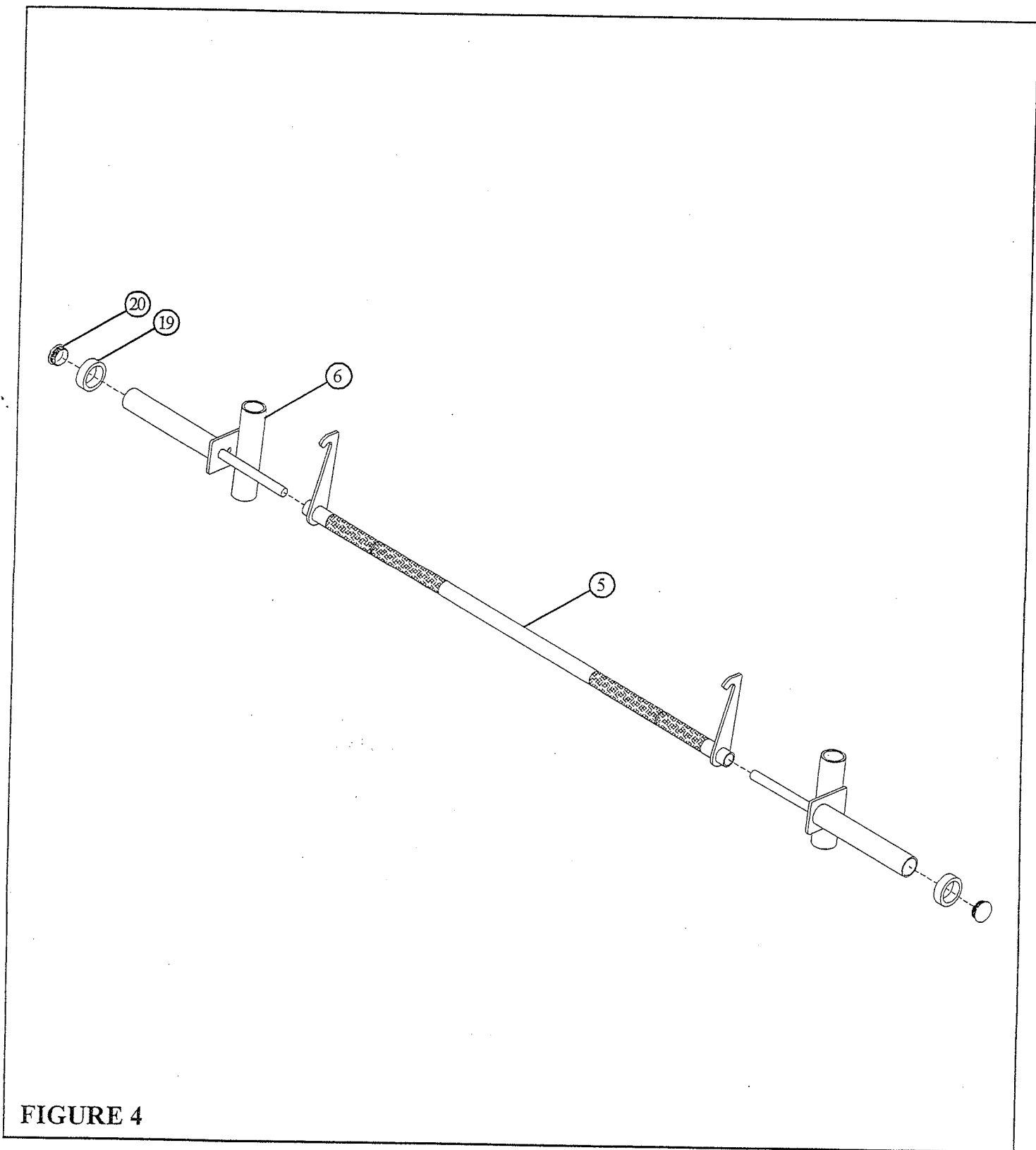
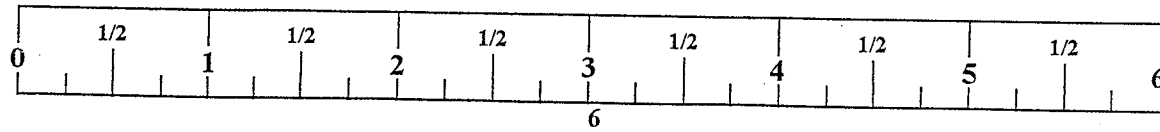

FIGURE 4

STEP 4:

- Insert one 1-3/4" ROUND END CAP (20) into the end of each HOUSING (6) as shown in FIGURE 4.
- Slide one 2-1/2" OD BUMPER (19) over the end of each HOUSING (6) as shown in FIGURE 4.
- Insert the shaft of the HOUSINGS (6) into the ends of the SMITH BAR (5) as shown in FIGURE 4.



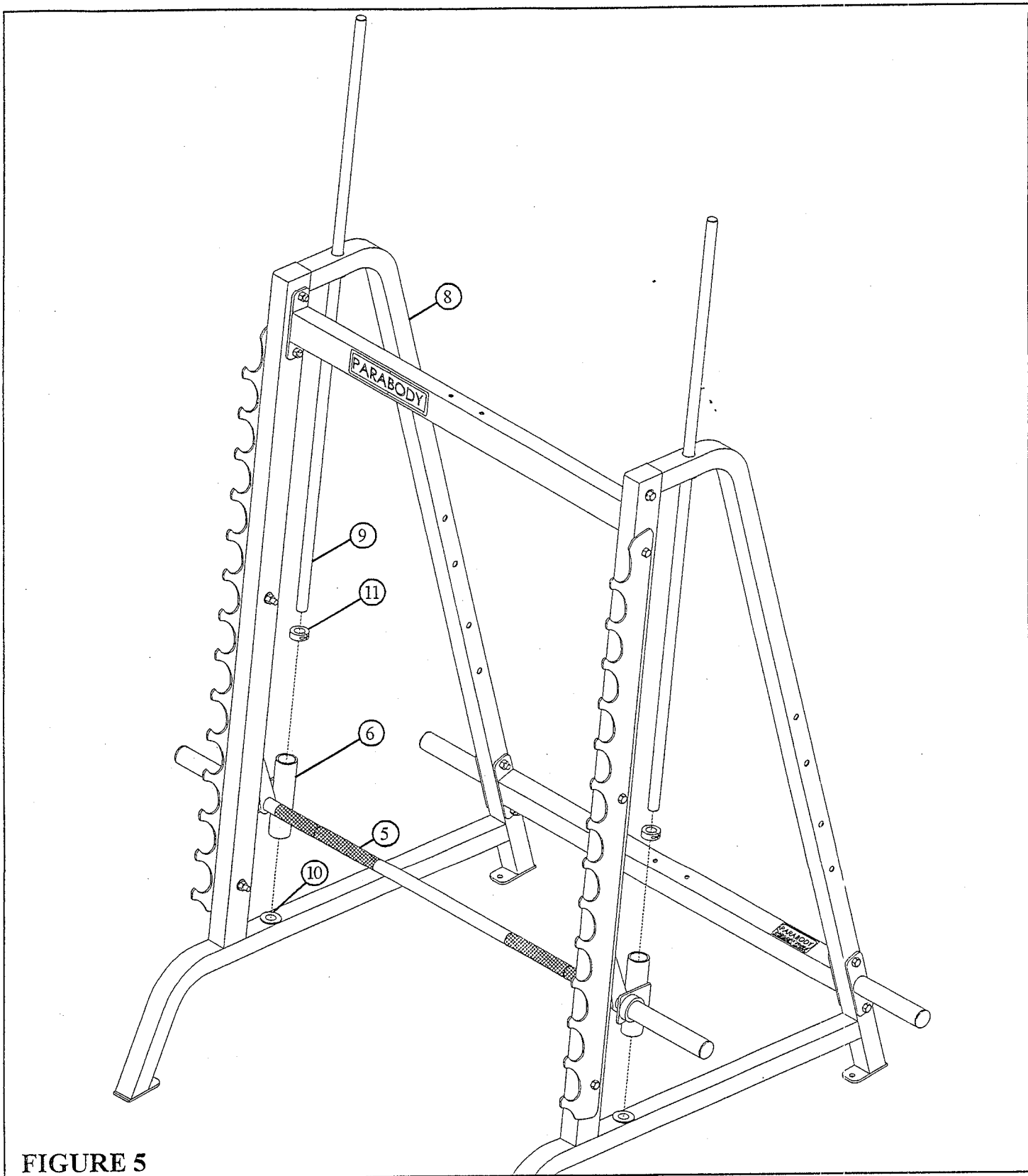

FIGURE 5

STEP 5:

- Hook the SMITH BAR (5) into the slots of the UPRIGHT FRAMES (8).
- **CAREFULLY** slide one GUIDE ROD (9) through the upper hole in the UPRIGHT FRAME (8). Slide one 1" SHAFT COLLAR (11) over the bottom of the GUIDE ROD (9), the **CAREFULLY** lower the GUIDE ROD (9) through the HOUSING (6) on the SMITH BAR (5) and into the bottom hole of the UPRIGHT FRAME (8). Repeat this step on the other side.
- Slide the 1" SHAFT COLLARS (11) up the GUIDERODS (9) to the bushing and **SECURELY TIGHTEN**.

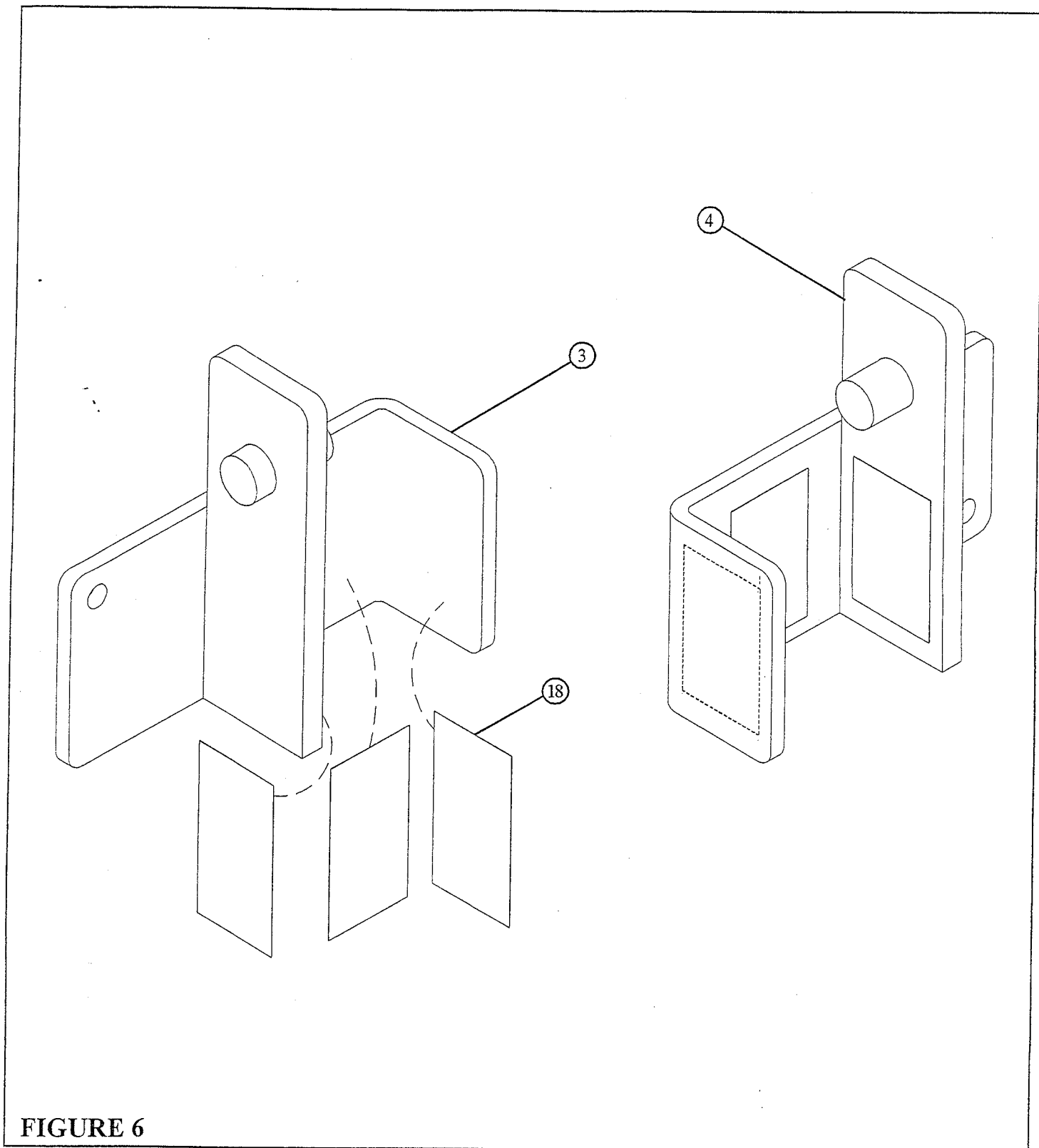
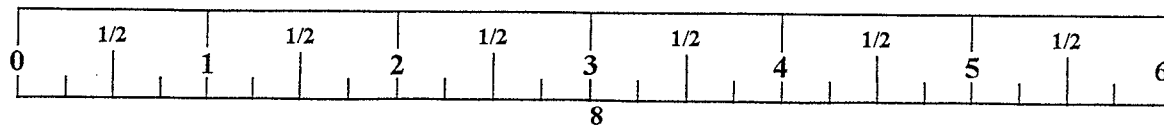

FIGURE 6

STEP 6:

- Attach six 3-1/4 X 1-3/4" GLIDES (18) to the LEFT & RIGHT SAFETY STOPS (3 & 4) as shown in FIGURE 6 using the following steps:
 - Thoroughly clean all surfaces where the 3-1/4 X 1-3/4" GLIDES (18) are to be attached.
 - Remove the 3-1/4 X 1-3/4" GLIDES (18) from the paper backing and firmly apply them to all shown surfaces.



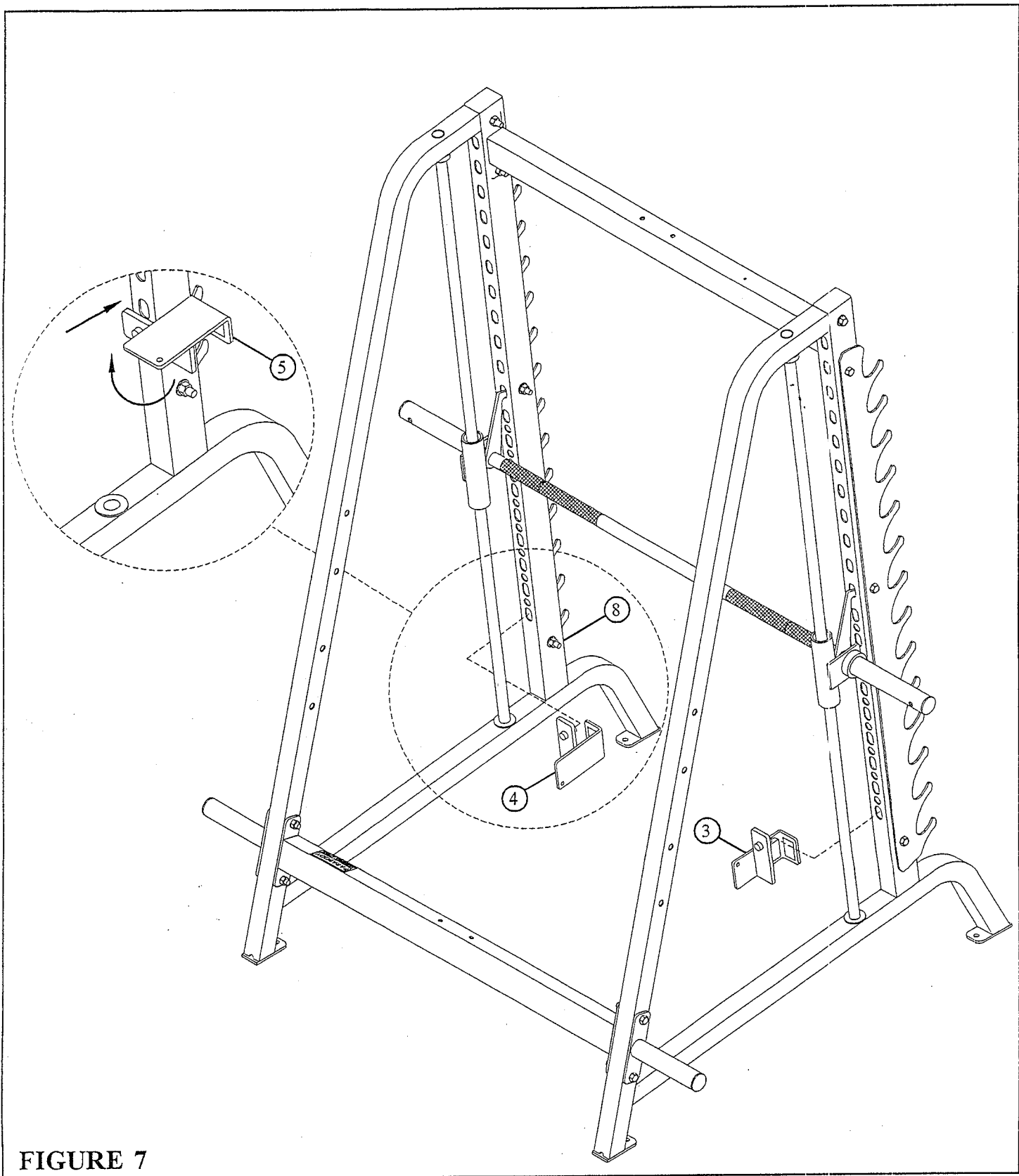

FIGURE 7

STEP 7:

- Assemble the LEFT & RIGHT SAFETY STOPS (3 & 4) to the UPRIGHT FRAMES (8) as shown in FIGURE 7.

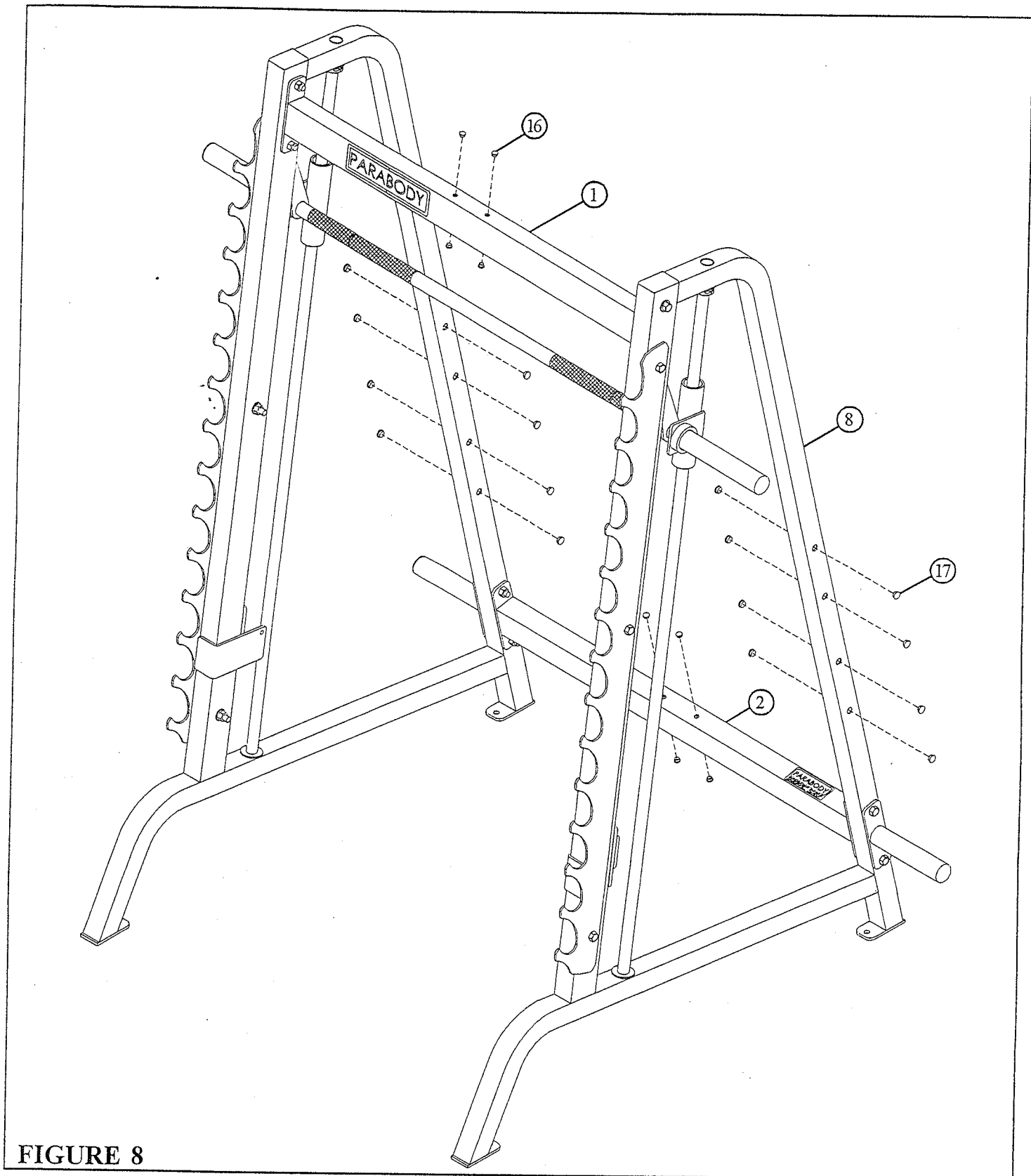

FIGURE 8

STEP 8:

- Insert sixteen 9/16" CAP PLUGS (17) into the exposed holes in the UPRIGHT FRAMES (8) as shown in FIGURE 8.
- Insert eight 7/16" CAP PLUGS (16) into the exposed holes in the UPPER & LOWER CROSS BRACES (1 & 2) as shown in FIGURE 8.

Thank you for purchasing the Parabody 888101 SMITH MACHINE. If unsure of proper use of equipment, call your local Parabody distributor or call the Parabody customer service department at (800) 328-9714.

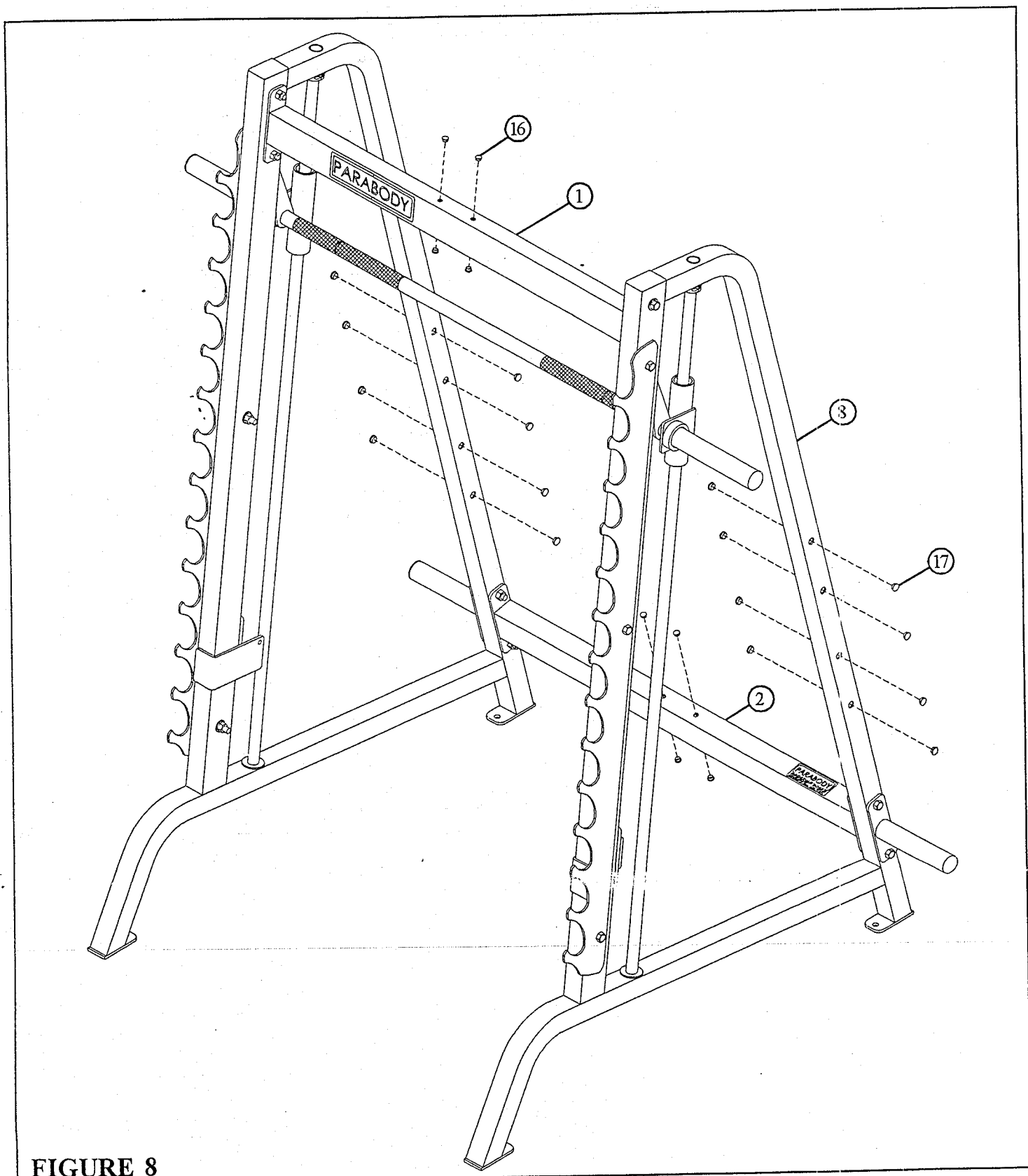

FIGURE 8

STEP 8:

- Insert sixteen 9/16" CAP PLUGS (17) into the exposed holes in the UPRIGHT FRAMES (8) as shown in FIGURE 8.
- Insert eight 7/16" CAP PLUGS (16) into the exposed holes in the UPPER & LOWER CROSS BRACES (1 & 2) as shown in FIGURE 8.

Thank you for purchasing the Parabody 888101 SMITH MACHINE. If unsure of proper use of equipment, call your local Parabody distributor or call the Parabody customer service department at (800) 328-9714.