

874 MULTI ANGLE BENCH ASSEMBLY INSTRUCTIONS

8. Slide one (1) 3/4 IN. WASHER over the **POST** of the **ADJUSTMENT SLIDE**. Insert the **POST** of the **ADJUSTMENT SLIDE** through the 3/4 IN. FLANGE BEARINGS on the **SLIDE MOUNT** as shown on drawing, and **SECURE** in place with one (1) STAR LOCK COLLAR.
9. Pull back the **SPRING PIN** on the **SWIVEL**, and insert the **ADJUSTMENT SLIDE**, down to the first adjustment hole. Release the **SPRING PIN** into the hole.
10. **SECURELY** assemble the **SLIDE MOUNT** to the top of the **BACK PAD** as shown on drawing using three (3) 3/8 X 1-1/4 IN. BOLTS, three (3) 3/8 IN. LOCK WASHERS, and three (3) 3/8 IN. WASHERS. **(BEFORE THIGHTENING, ADJUST THE BACK PAD UP AND DOWN TO CENTER THE ADJUSTMENT SLIDE)**
11. **SECURE** the **ADJUSTMENT SLIDE** in place by turning the 'T' handle of the **SPRING PIN ASSEMBLY** clockwise.
12. To adjust the **SEAT PAD** for **LEG EXTENSION** position, pull out on the **U-PIN**. Rotate the **U-PIN** back pass the **FIRST PIN STOP**. Release the **U-PIN**, and allow it to rest up against the **FIRST PIN STOP**.
13. To adjust the **SEAT PAD** for the **DECLINE** or **INCLINE** position, rotate the **U-PIN** back to the **SECOND PIN STOP**.
14. Insert one (1) THUMBSCREW into the **UPRIGHT TUBE** of the **BENCH FRAME** as shown on drawing. This will be used for securing attachments in place.
15. There is no 2 IN. SQ. END CAP supplied for top of **UPRIGHT TUBE** on the **BENCH FRAME**. Attachments are mounted in this location.

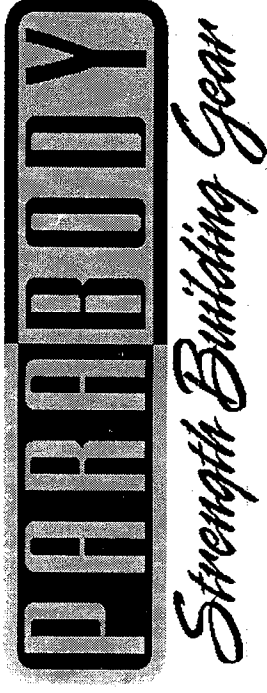

874 MULTI-ANGLE BENCH

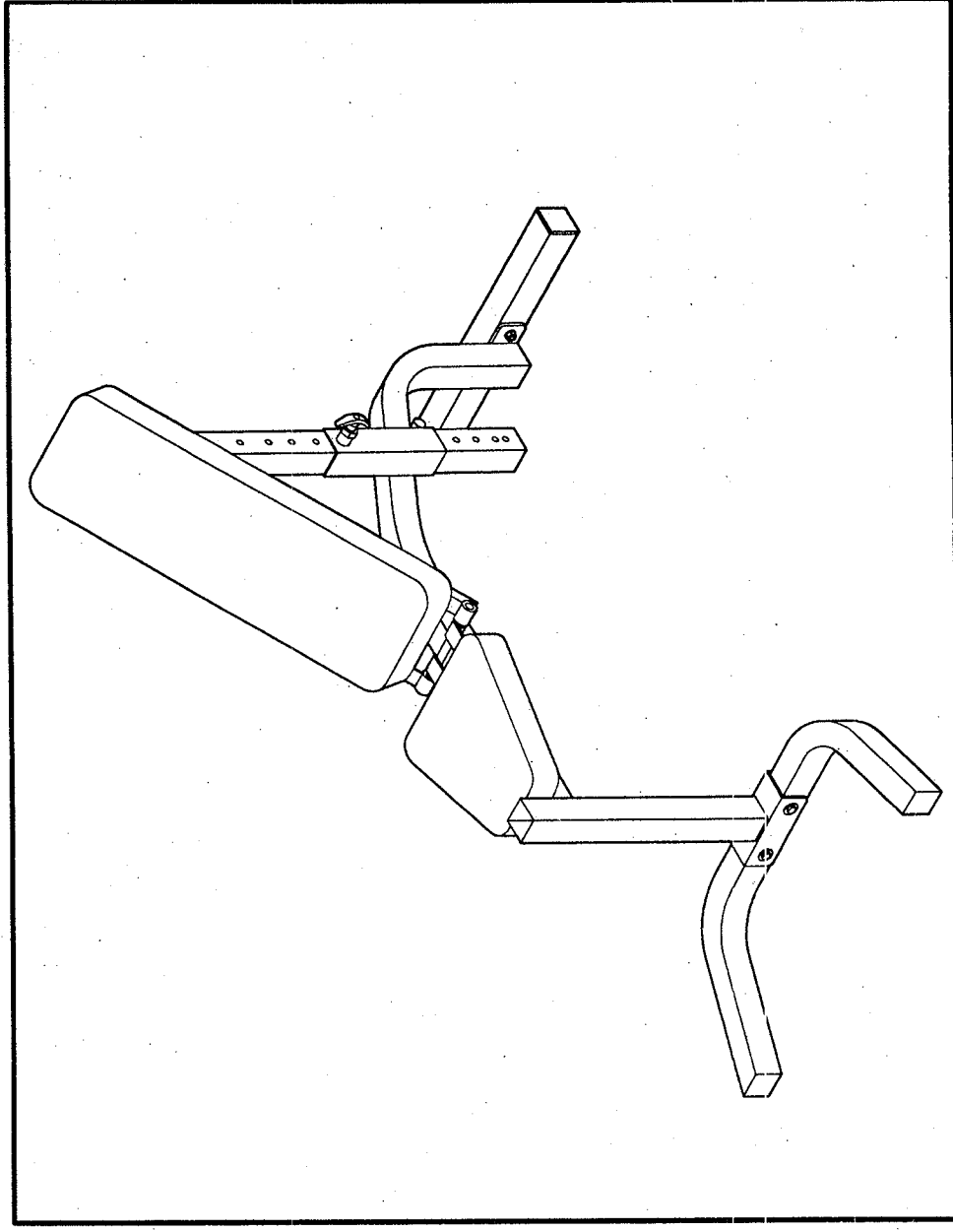

PRODUCT ASSEMBLY INSTRUCTIONS SHEETS

874 MULTI ANGLE BENCH ASSEMBLY INSTRUCTIONS

SORT AND COUNT ALL PARTS BEFORE BEGINNING ASSEMBLY

HARDWARE:

ITEM	NAME/DESCRIPTION	QTY
1.	3/8 X 3 IN. BOLT	4
2.	3/8 X 1-1/4 IN. BOLT	9
3.	3/4 IN. WASHER	1
4.	3/8 IN. WASHER	17
5.	3/8 IN. LOCK WASHER	9
6.	3/8 IN. LOCK NUT	4
8.	STAR LOCK COLLAR	2
9.	SPRING PIN ASSEMBLY	1
10.	1/2 X 1 IN. SPRING	1
11.	PAL NUT	1

WELDMENTS/PARTS:

ITEM	NAME/DESCRIPTION	QTY
1.	BENCH FRAME WLDMT. (6415401)	1
	3/4 IN. FLANGE BEARING	2
	THUMBSCREW	1
2.	SWIVEL WLDMT. (6415201)	1
3.	ADJUSTMENT SLIDE WLDMT. (6415001)	1
	1-3/4 IN. SQ. END CAP	2
4.	SLIDE MOUNT WLDMT. (6414701)	1
	2 IN. SQ. END CAP	1
	3/4 IN. FLANGE BEARING	2
5.	REAR BASE TUBE (6236501)	1
	2 IN. SQ. END CAP	2
6.	FRONT BASE TUBE (6259101)	1
	2 IN. SQ. END CAP	2
7.	HINGE TAB (6406401)	2
8.	U-PIN (6406501)	1
9.	SEAT PAD (6452501)	1
10.	BACK PAD (6456701)	1
11.	ANGLE WLDMNT, LEFT (6493301)	1
12.	ANGLE WLDMNT, RIGHT (6493401)	1

NOTE: BOLT LENGTH IS MEASURED FROM THE UNDERSIDE OF THE HEAD OF THE BOLT.

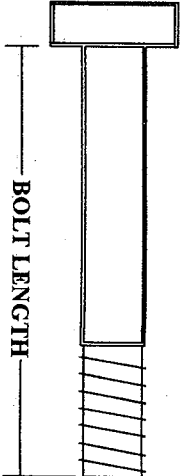

BOLT LENGTH RULER:

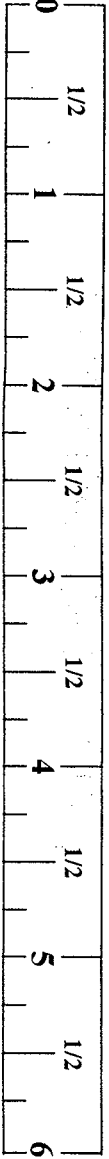

874 MULTI ANGLE BENCH ASSEMBLY INSTRUCTIONS

THANK YOU

FOR PURCHASING THE 874 MULTI ANGLE BENCH, PLEASE SAVE THESE ASSEMBLY INSTRUCTIONS FOR YOUR PERSONAL REFERENCE, AND ADDITIONAL SERVICE INFORMATION.

IMPORTANT

- THE 874 MULTI ANGLE BENCH MUST BE ASSEMBLED ON A FLAT, LEVEL SURFACE TO ASSURE ITS PROPER FUNCTION.
- IF YOU EXPERIENCE ANY PROBLEM WITH THE ASSEMBLY OF THIS PRODUCT, PLEASE CONTACT YOUR DEALER OR YOUR PARABODY CUSTOMER SERVICE REPRESENTATIVE AT: 1-800-328-9714
- **TOOLS REQUIRED:** RATCHET, 9/16 SOCKET OR WRENCH, ADJUSTABLE WRENCH, AND RUBBER MALLET or HAMMER

1. Insert one (1) U-PIN through the POST on the BENCH FRAME, as shown on drawing. Slide one (1) 1/2 X 1 IN. SPRING over the U-PIN. Attach one (1) PAL NUT to the end of the U-PIN.
2. SECURELY assemble the REAR BASE TUBE to the BENCH FRAME as shown on drawing, using two (2) 3/8 X 3 IN. BOLTS, four (4) 3/8 IN. WASHERS, and two (2) 3/8 IN. LOCK NUTS.
3. SECURELY assemble the FRONT BASE TUBE to the BENCH FRAME as shown on drawing, using two (2) 3/8 X 3 IN. BOLTS, four (4) 3/8 IN. WASHERS, two (2) 3/8 IN. LOCK NUTS.
4. To assemble the SEAT PAD to the BENCH FRAME, start by sliding two (2) HINGE TABS over the PIN on the BENCH FRAME, (ONE ON EACH SIDE) as shown on drawing, and SECURELY assemble each HINGE TAB to the SEAT PAD using two (2) 3/8 X 1-1/4 IN. BOLTS, two (2) 3/8 IN. LOCK WASHERS, and two (2) 3/8 IN. WASHERS. (MAKE SURE THE BACK PAD IS CENTERED ON THE BENCH FRAME BEFORE TIGHTENING)
5. To assemble the BACK PAD to the BENCH FRAME, slide the LEFT & RIGHT ANGLE WLDMNTS over the PIN on the BENCH FRAME (ONE ON EACH SIDE) as shown on drawing, and SECURELY assemble to the BACK PAD using four (4) 3/8 X 1-1/4 IN. BOLTS, four (4) 3/8 IN. LOCK WASHERS, and four (4) 3/8 IN. WASHERS. (MAKE SURE THE BACK PAD IS CENTERED ON THE BENCH FRAME BEFORE TIGHTENING)
6. SECURELY assemble one (1) SPRING PIN ASSEMBLY to the SPRING PIN HOUSING on the SWIVEL, as shown in (DETAIL A). (!!! IMPORTANT !!!) TIGHTEN THE NUT OF THE SPRING PIN ASSEMBLY SECURELY
7. Insert the SHAFT of the SWIVEL through the 3/4 IN. FLANGE BEARING on the BENCH FRAME as shown on drawing, and SECURE in place with one (1) STAR LOCK COLLAR.

DASH NO	DESCRIPTION
01	AS SHOWN

REVISIONS			
REV	DESCRIPTION	CHG NO	APP'D
A	NEW RELEASE		
			DATE

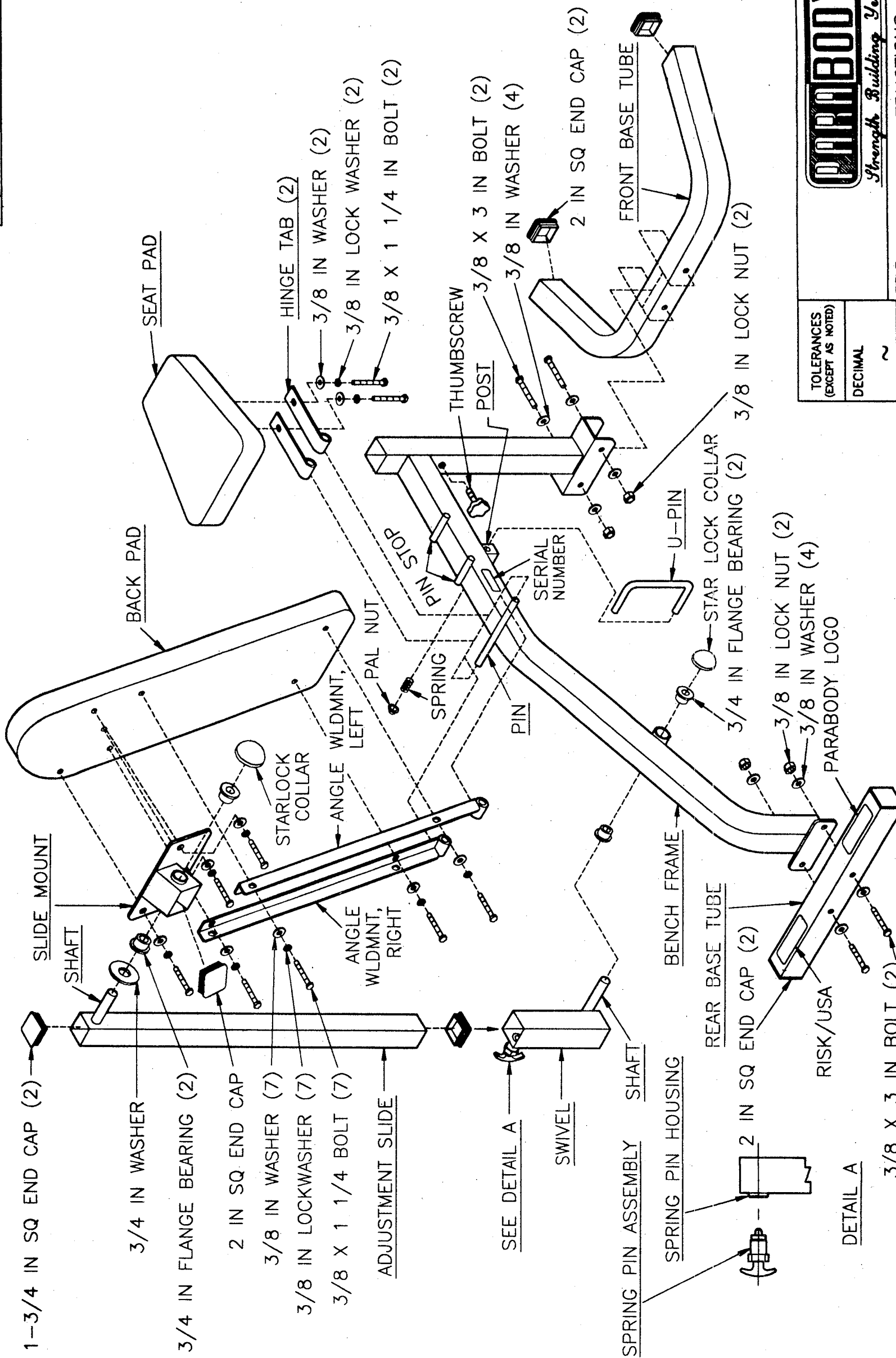

DETAIL A

3/8 X 3 IN BOLT (2)

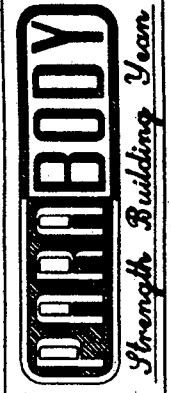

TOLERANCES (EXCEPT AS NOTED)	
DECIMAL	~
FRACTIONAL	±1/16
ANGULAR	±1'

TITLE ASSEMBLY INSTRUCTIONS			
SCALE	NONE	SIZE	DRAWING NO.
SHEET	1 OF 1	B	874 M/A BENCH
DR	Kelly	CHK'D	APP'D