

Strength Building Gear

858

SELECTORIZED LAT MACHINE

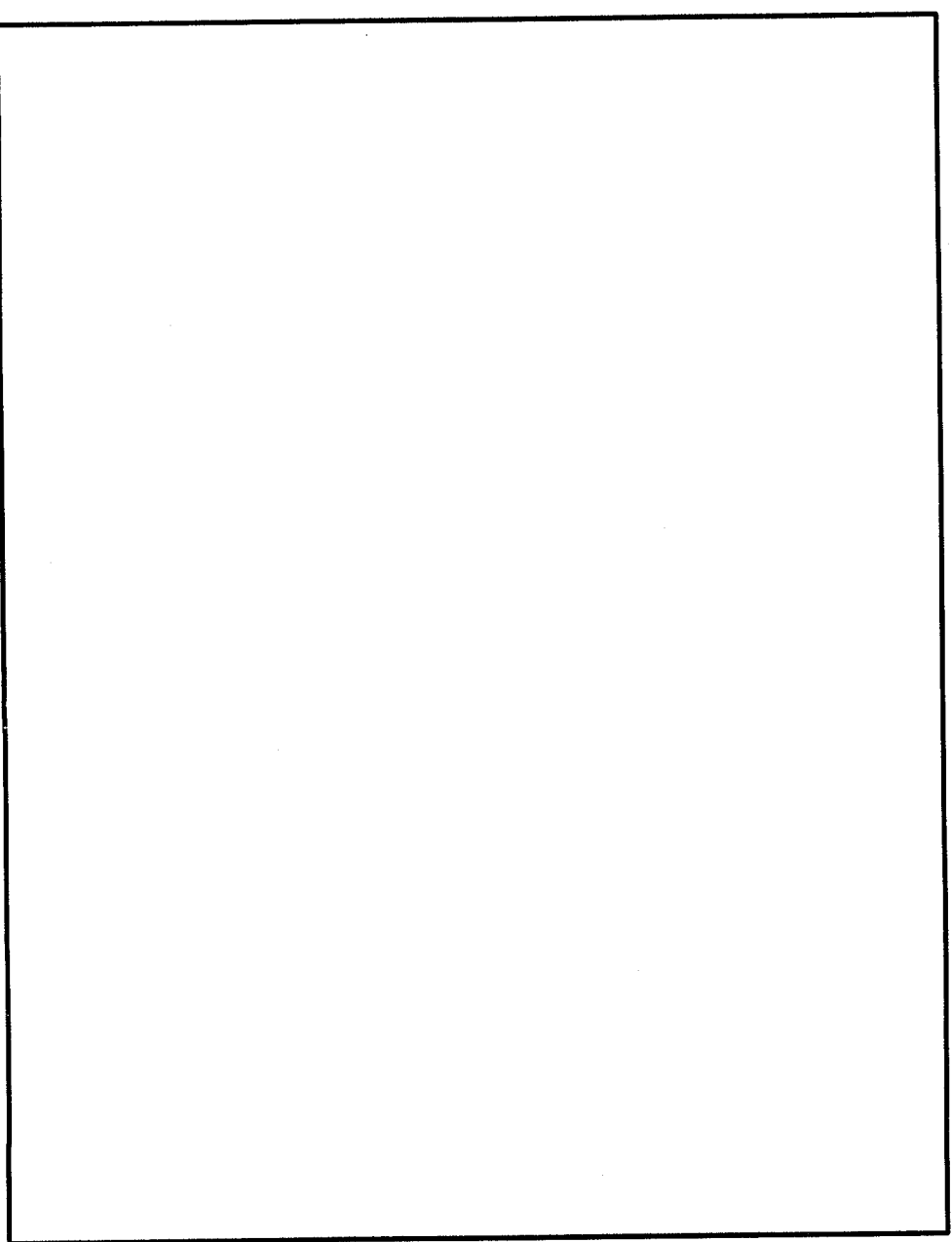

PRODUCT ASSEMBLY
INSTRUCTIONS SHEETS

REVISION A

858 SELECTORIZED LAT MACHINE ASSEMBLY PARTS LIST

SORT AND COUNT ALL PARTS BEFORE BEGINNING ASSEMBLY

HARDWARE:		QTY
ITEM	NAME/DESCRIPTION	
1.	3/8 X 3 IN. BOLT	12
2.	3/8 X 2-3/4 IN. BOLT	2
3.	3/8 X 2-1/2 IN. BOLT	1
4.	3/8 X 2-1/4 IN. BOLT	2
5.	3/8 X 1-3/4 IN. BOLT	2
6.	3/8 X 1-1/2 IN. BOLT	1
7.	1/2 IN. WASHER	4
8.	3/8 IN. LOCK WASHER	20
9.	3/8 IN. WASHER	16
10.	3/8 IN. NUT	17
11.	5/16 IN. SNAP HOOK	3
12.	STAR LOCK COLLAR	2
13.	WEIGHT STACK PIN	1
14.	CABLE RETAINING CLIP	1
15.	SPACER	9
16.	KNOB	1
17.	PLUNGER	1
18.	SPRING	1
19.	COTTER PIN	1
20.	1-1/2 X 2-1/2 IN. END CAP	2
21.	2 IN. SQ. END CAP	1
22.	1-3/4 IN. SQ. END CAP	1
23.	1-1/2 IN. SQ. END CAP	1
24.	ROD END COVER	2
25.	RUBBER O-RING	2
26.	1 X 8 IN. GRIP	4
27.	WEIGHT PLATE BUSHING	40
28.	WEIGHT STACK CUSHION	2
29.	PARAGLIDE STRIPS	16
30.	2-1/2 X 5-1/2 IN. NON SKID STRIP	2
31.	GUIDE ROD PIN	2

NOTE: BOLT LENGTH IS MEASURED FROM THE UNDERSIDE OF THE HEAD OF THE BOLT.

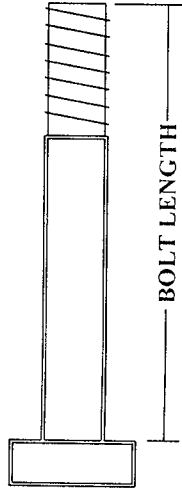

BOLT LENGTH RULER:

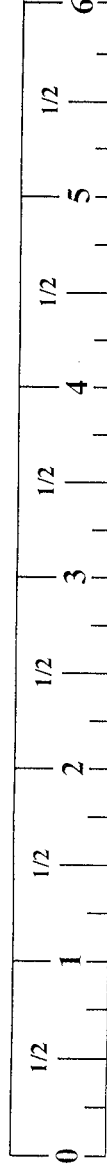

858 SELECTORIZED LAT MACHINE ASSEMBLY INSTRUCTIONS

29. To install SECONDARY CABLE, start by inserting the end of the CABLE without the BALL under the FRONT PULLEY in the LOW ROW PULLEY HOUSING on the FRONT UPRIGHT.
 - Pull the CABLE under the FRONT PULLEY and through the HOLE of the FRONT UPRIGHT to the REAR PULLEY on the opposite side. Pull the CABLE until the WHITE BALL stops against the FRONT PULLEY and the LOW ROW PULLEY HOUSING.
 - Pull the CABLE around the REAR PULLEY and up to the SECOND PULLEY on the PULLEY BLOCK SYSTEM. (NOTE: THE CABLE MUST BE ROUTED AROUND THE SECOND PULLEY FROM THE REAR TO THE FRONT. SEE CABLE ROUTING DIAGRAM) (DETAIL D)
 - Pull the CABLE around the SECOND PULLEY of the PULLEY BLOCK SYSTEM and down to the HOLE above the REAR PULLEY on the FRONT UPRIGHT. Attach the end of the CABLE to the FRONT UPRIGHT, using one (1) 3/8 X 2-1/2 IN. BOLT, one (1) 3/8 IN. WASHER, one (1) 3/8 IN. LOCK WASHER and one (1) 3/8 IN. NUT. (SEE CABLE ROUTING DIAGRAM ON DRAWING) (DETAIL D)
30. TIGHTEN ALL LOOSE PULLEY CONNECTIONS MADE TO THIS POINT.
31. Slide four (4) 1 X 8 IN. GRIPS over both ends of the LAT BAR, and the LOW ROW BAR. (NOTE: IF A LUBRICANT IS REQUIRED, RUBBING ALCOHOL THOROUGHLY COATING THE INSIDE OF THE GRIP IS THE BEST MATERIAL TO USE.)
32. Attach the LAT BAR to the PRIMARY CABLE, using one (1) 5/16 IN. SNAP HOOK. (SEE DETAIL D)
33. Attach two (2) 5/16 IN. SNAP HOOKS to each end of the CHAIN, and attach it to the LOW ROW BAR. When doing LOW PULLEY EXERCISES simply attach the CHAIN to the SECONDARY CABLE and adjust the LOW ROW BAR on the CHAIN LINKS.
34. Use one (1) WEIGHT STACK PIN to adjust the desired number of WEIGHT PLATES on the WEIGHT STACK.

!!! WARNING !!!

MAKE SURE SNAP HOOKS ARE FASTENED BEFORE DOING EXERCISES

!!! WARNING !!!

DO NOT OPERATE THIS MACHINE WITH LAT BAR OFF SAFETY HOOKS EXCEPT DURING HIGH PULLEY EXERCISES

!!! WARNING !!!

THE LAT BAR IS NOT TO BE USED FOR PULL-UPS

858 SELECTORIZED LAT MACHINE ASSEMBLY INSTRUCTIONS

19. Slide the **HEAD PLATE ASSEMBLY** down over the **GUIDE RODS** onto the **WEIGHT STACK**. (SEE **DRAWING**)
20. Slide two (2) **RUBBER O-RINGS** over each **GUIDE ROD**.
21. Position the **GUIDE RODS** under the **GUIDE ROD BRACKET** of the **TOP BOOM**, and hold in place using two (2) **GUIDE ROD PINS**. (SEE **DETAIL F**)
22. Slide the two (2) **RUBBER O-RINGS** up the **GUIDE RODS** to the **GUIDE ROD BRACKET** of the **TOP BOOM**.
23. **LOOSELY** Assemble four (4) 3-1/2 X 1 IN. **BUSHING PULLEYS** into the **TOP BOOM**, using four (4) 3/8 X 3 IN. **BOLTS**, eight (8) **SPACERS**, four (4) 3/8 IN. **LOCK WASHERS**, and four (4) 3/8 IN. **NUTS**. (SEE **DRAWING**)
24. **AT THIS TIME TIGHTEN ALL LOOSE FRAME CONNECTIONS MADE TO THIS POINT.**
25. Attach the **WEIGHT STACK LABELS** (designated #15 to #205) to the **WEIGHT STACK PLATES**. (SEE **DETAIL B**)
26. Attach the **SEAT PAD** to the **SEAT SUPPORT TUBE** of the **FRONT UPRIGHT**, using two (2) 3/8 X 2-3/4 IN. **BOLTS**, two (2) 3/8 IN. **LOCK WASHERS**, and two (2) 3/8 IN. **WASHERS**. (NOTE: THE **SEAT PAD** SHOULD EXTEND BEYOND THE **SEAT SUPPORT TUBE** BY APPROXIMATELY ONE INCH)
27. To assemble the **PULLEY BLOCK SYSTEM**, assemble two (2) **PAINTED CONNECTORS** around two (2) 3-1/2 O.D. X 1 IN. **BUSHING PULLEYS**, using two (2) 3/8 X 2-1/4 IN. **BOLTS**, four (4) 3/8 IN. **WASHERS**, two (2) 3/8 IN. **LOCK WASHERS** and two (2) 3/8 IN. **NUTS**. (NOTE: THE **HOLES** IN THE **PAINTED CONNECTORS** ARE OVAL, MAKE SURE THAT THE **PULLEYS** ARE AT THE **MAXIMUM WIDTH** SEE **DETAIL C**)
28. To install the **PRIMARY CABLE**, start by inserting the end of the **CABLE** with the **THREADED FITTING** between the **TOP PULLEY** and the **LAT BAR HOOK** on the **TOP BOOM**. (REMOVE **PULLEY FOR EASE OF INSTALLATION**)
 - Pull **CABLE** over **TOP PULLEY** until the **WHITE BALL** stops against the **PULLEY** and the **LAT BAR HOLDER**.
 - Pull **CABLE** over and down the **SECOND PULLEY** on the **TOP BOOM**. Run the **CABLE** around one **PULLEY** of the **PULLEY BLOCK SYSTEM** and up to the **THIRD PULLEY** on the **TOP BOOM**.
 - Pull **CABLE** over the **THIRD PULLEY**, and over and down the **FOURTH PULLEY** above the **WEIGHT STACK**. Attach the **CABLE** to the **HEAD PLATE ASSEMBLY** by threading the **STUD** into the **WEIGHT STACK SHAFT** and tighten completely. (SEE **CABLE ROUTING DIAGRAM ON DRAWING**) (**DETAIL D**)

858 SELECTORIZED LAT MACHINE ASSEMBLY PARTS LIST

SORT AND COUNT ALL PARTS BEFORE BEGINNING ASSEMBLY

WELDMENTS/PARTS: ITEM	NAME/DESCRIPTION	QTY
1.	BASE	(6262801)..... 1
2.	FRONT UPRIGHT	(6263101)..... 1
3.	REAR UPRIGHT	(6243001)..... 1
4.	ADJUSTABLE ROLLER PAD SLIDE	(6243801)..... 1
5.	GUIDE ROD	(6244301)..... 2
6.	TOP BOOM	(6263301)..... 1
7.	LAT BAR	(6275301)..... 1
8.	LOW ROW BAR	(6389701)..... 1
9.	PAINTED CONNECTOR	(6013701)..... 2
10.	SEAT PAD	(6459801)..... 1
11.	4 X 7 IN. ROLLER PAD	(6194601)..... 2
12.	WEIGHT STACK LABELS	(6246801)..... 1
13.	PRIMARY CABLE	(6262901)..... 1
14.	SECONDARY CABLE	(6244901)..... 1
15.	CHAIN	(6075905)..... 1
16.	WEIGHT STACK SHAFT	(6284501)..... 1
17.	WEIGHT WEIGHT PLATE	(6223001)..... 1
18.	HEAD WEIGHT PLATE	(6214501)..... 20
19.	3-1/2 O.D. X 1 IN. BUSHING PULLEY	(3116201)..... 6
20.	4-1/2 O.D. X 1 IN. BUSHING PULLEY	(3116101)..... 2

858 SELECTORIZED LAT MACHINE ASSEMBLY INSTRUCTIONS

THANK YOU

FOR PURCHASING THE 858 SELECTORIZED LAT MACHINE. PLEASE SAVE THESE ASSEMBLY INSTRUCTIONS FOR YOUR PERSONAL REFERENCE, AND ADDITIONAL SERVICE INFORMATION.

IMPORTANT

- THE 858 SELECTORIZED LAT MACHINE MUST BE ASSEMBLED ON A FLAT, LEVEL SURFACE TO ASSURE ITS PROPER FUNCTION.
- PARABODY STRONGLY RECOMMENDS THAT THIS PRODUCT BE ASSEMBLED BY TWO PEOPLE TO AVOID POSSIBLE INJURY.
- KEEP ALL FRAME CONNECTIONS LOOSE, UNTIL INSTRUCTED IN THE ASSEMBLY STEP SEQUENCES TO SECURELY TIGHTEN.
- IF YOU EXPERIENCE ANY PROBLEM WITH THE ASSEMBLY OF THIS PRODUCT, PLEASE CONTACT YOUR DEALER OR YOUR PARABODY CUSTOMER SERVICE REPRESENTATIVE AT: 1-800-328-9714
- TOOLS REQUIRED: RATCHET, 9/16 SOCKET or WRENCH, ADJUSTABLE WRENCH, and RUBBER Mallet or HAMMER

1. Insert one (1) 2 IN. SQ. END CAP into the front end of the **BASE SECTION**, and two (2) 1-1/2 X 2-1/2 IN. END CAPS into the ends of the **BASE LEG**.
2. Apply two (2) 2-1/2 X 5-1/2 IN. NON SKID STRIPS to the **FOOT BRACE TUBE** on the **BASE SECTION** as shown on drawing.
3. **LOOSELY** assemble the **REAR UPRIGHT** to the **BASE SECTION**, using two (2) 3/8 X 3 IN. BOLTS, four (4) 3/8 IN. WASHERS, two (2) 3/8 IN. LOCK WASHERS, and two (2) 3/8 IN. NUTS.
4. **LOOSELY** assemble the **FRONT UPRIGHT** to the **BASE SECTION**, using two (2) 3/8 X 3 IN. BOLTS, four (4) 3/8 IN. WASHERS, two (2) 3/8 IN. LOCK WASHERS, and two (2) 3/8 IN. NUTS.
5. Insert one (1) 1-3/4 IN. SQ. END CAP into the end of the **SEAT SUPPORT TUBE** on the **FRONT UPRIGHT**.
6. **LOOSELY** attach one (1) 4-1/2 O.D. X 1 IN. BUSHING PULLEY to the **LOW ROW PULLEY HOUSING**, on the **FRONT UPRIGHT**, using one (1) 3/8 X 1-3/4 IN. BOLT, one (1) 3/8 IN. LOCK WASHER, and one (1) 3/8 IN. NUT. (SEE DRAWING)
7. **LOOSELY** attach one (1) 4-1/2 O.D. X 1 IN. BUSHING PULLEY, and one (1) **CABLE RETAINING CLIP** to the **PULLEY BRACKET** on the **FRONT UPRIGHT**, using one (1) 3/8 X 1-3/4 IN. BOLT, one (1) 3/8 IN. LOCK WASHER, and one (1) 3/8 IN. NUT. (SEE DRAWING)

858 SELECTORIZED LAT MACHINE ASSEMBLY INSTRUCTIONS

8. Attach eight (16) PARAGLIDE STRIPS (TWO AT EACH CORNER) to the **ADJUSTABLE ROLLER PAD SLIDE** as shown in (DETAIL A) using the following steps:
 - A. Thoroughly clean all inside surfaces where the PARAGLIDE STRIPS are to be attached.
 - B. Remove the paper backing from the PARAGLIDE STRIPS and firmly apply them to all shown surfaces (16 places).
9. Attach two (2) 4 X 7 IN. ROLLER PADS to the **ADJUSTABLE ROLLER PAD SLIDE** using two (2) STAR LOCK COLLARS.
10. Assemble the SPRING PIN ASSEMBLY to the **ADJUSTABLE ROLLER PAD SLIDE**, using one (1) KNOB, one (1) PLUNGER, one (1) SPRING, one (1) SPACER, and one (1) COTTER PIN, using the following steps:
 - A. Assemble the KNOB to the PLUNGER.
 - B. Insert the PLUNGER through the first hole of the HOUSING.
 - C. Slip the SPRING and the SPACER over the end of the PLUNGER. (IN THAT ORDER)
 - D. Insert the PLUNGER through the second hole of the HOUSING.
 - E. Pull back SPACER on the PLUNGER and insert the COTTER PIN through the hole.
 - F. (SEE DETAIL A)
11. Insert one (1) 1-1/2 IN. SQ. END CAP into the top end of SPRING PIN HOUSING on the **ADJUSTABLE ROLLER PAD SLIDE**. (SEE DETAIL A)
12. Slide the **ADJUSTABLE ROLLER PAD SLIDE** down over the **FRONT UPRIGHT**, and engage the SPRING PIN into any adjustment hole.
13. Slide the two (2) ROD END COVERS over the ends of the **LAT BAR HOLDER** on the **TOP BOOM**.
14. **LOOSELY** assemble the **TOP BOOM** to the **REAR** and **FRONT UPRIGHTS**, using four (4) 3/8 X 3 IN. BOLTS, four (4) 1/2 IN. WASHERS, four (4) 3/8 IN. LOCK WASHERS, and four (4) 3/8 IN. NUTS. (NOTE: THE FOUR (4) 1/2 IN. WASHERS ARE TO BE USED IN BETWEEN THE TOP BOOM AND THE FRONT UPRIGHT ON BOTH SIDES)
15. **SECURELY** assemble the **WEIGHT STACK SHAFT** into the **HEAD PLATE** using one (1) 3/8 X 1-1/2 IN. BOLT one (1) 3/8 IN. LOCK WASHER, and one (1) 3/8 IN. WASHER.
16. Press two (2) **WEIGHT PLATE BUSHINGS** each, into the top of twenty (20) **WEIGHT PLATES**. (40 BUSHINGS TOTAL) (SEE DETAIL B)
17. Place each of the two (2) **WEIGHT STACK CUSHIONS (RADIUS EDGES FACING UP)** over the **GUIDE ROD HOLES** on the **BASE SECTION**. Insert each of the two (2) **GUIDE RODS** through the **WEIGHT STACK CUSHIONS** and into the **BASE SECTION**. (NOTE: LUBRICATE **GUIDE RODS WITH A SILICON OR TEFLON SPRAY THAT IS AVAILABLE AT MOST HARDWARE STORES**)
18. **USING EXTREME CARE**, slide each of the twenty (20) **WEIGHT PLATES** down over the **GUIDE RODS** onto the **BASE SECTION**. (NOTE: THE KEY HOLE OF THE **WEIGHT PLATES SHOULD ALL BE FACING THE SAME WAY SEE DRAWING**)

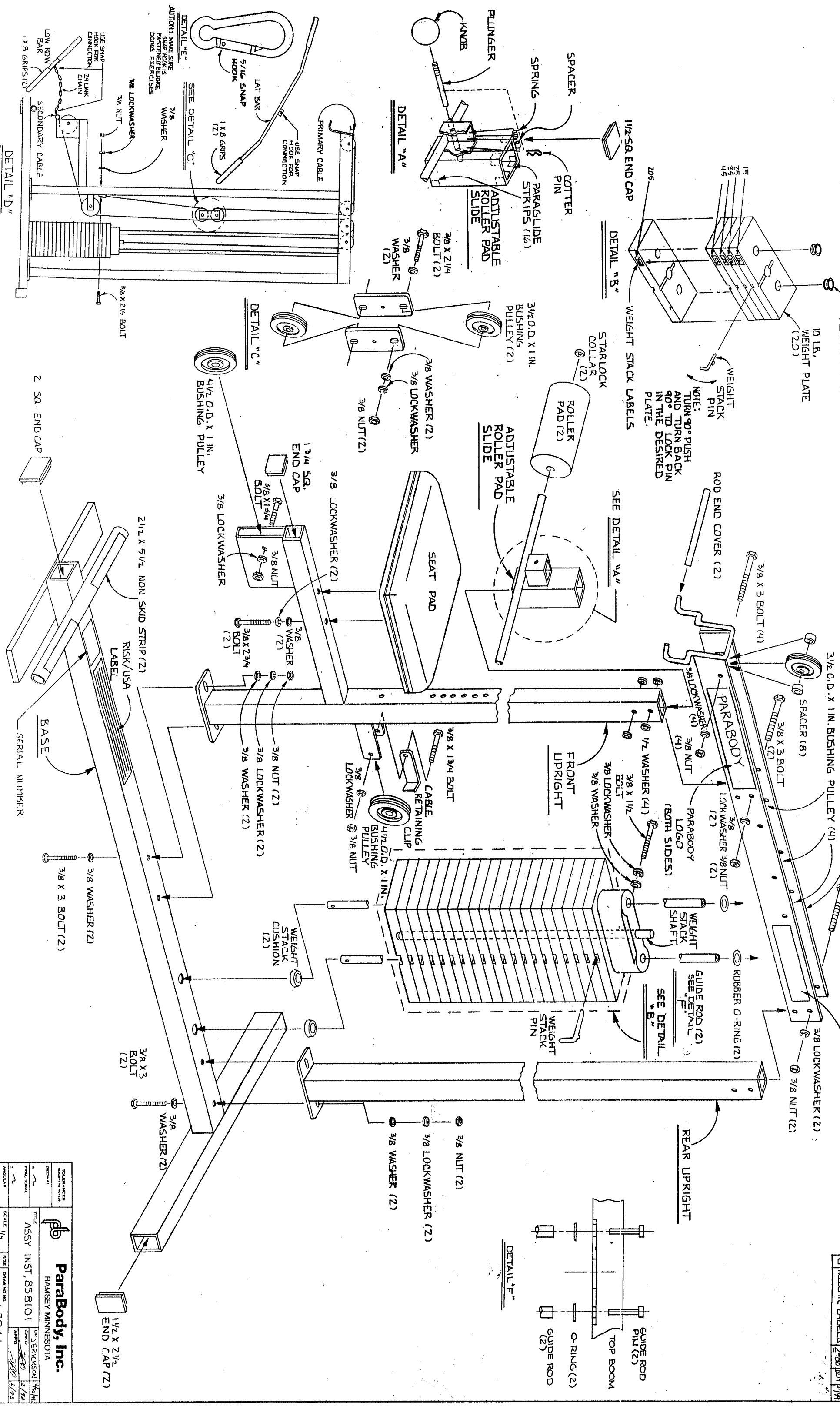

Parabody, Inc.
 RAMSEY, MINNESOTA
 TITLE: ASSY INST, 858101
 DRAWING NO: 63941
 SCALE: 1/4" = 1"
 SHEET 1 OF 1
 DATE: 2/86
 BY: 11/4