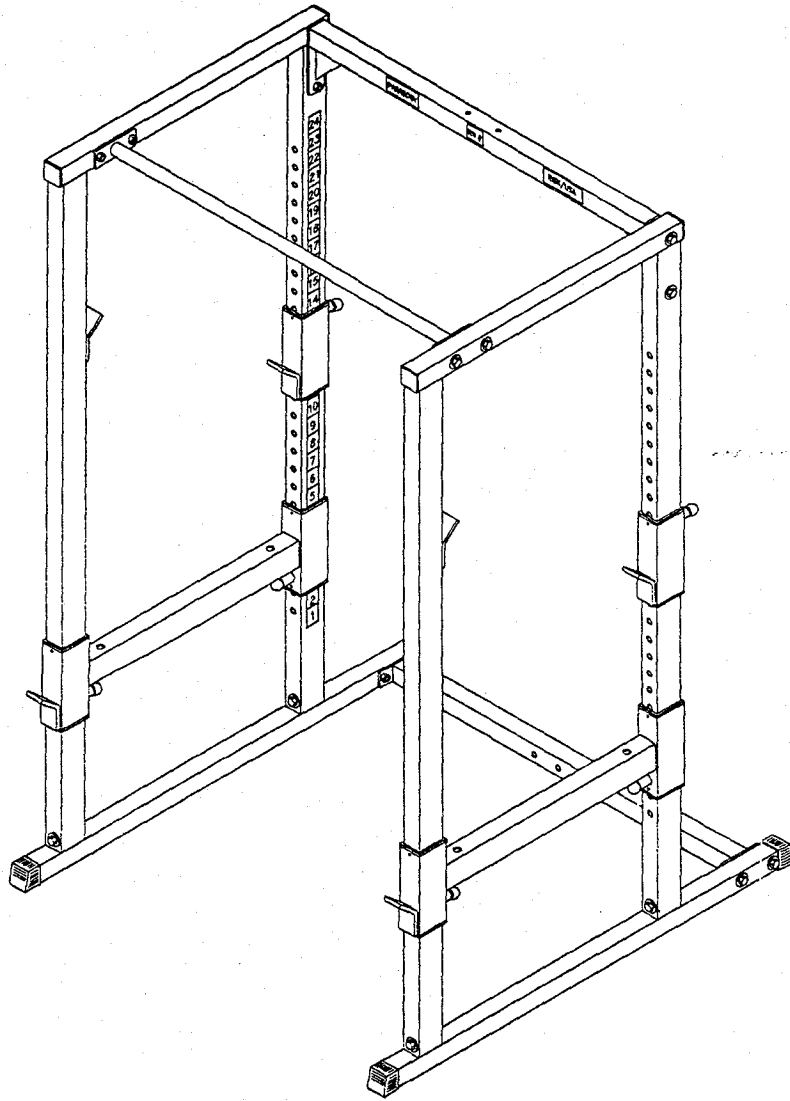


# PARABODY

## *Serious Steel*

### 843102 POWER RACK

---



---

## ASSEMBLY INSTRUCTIONS

## IMPORTANT NOTES

WELCOME TO THE WORLD OF ***Serious Steel!***

**Please note:**

- \* Thank you for purchasing the Parabody 843102 POWER RACK. Please read these instructions thoroughly and keep them for future reference. This product must be assembled on a flat, level surface to assure its proper function.
- \* We recommend cleaning your product (pads and frame) on a regular basis, using warm soapy water. Touch-up paint can be purchased from your Parabody customer service representative at (800) 328-9714.

There is a risk assumed by individuals who use this type of equipment. To minimize risk, please follow these rules:

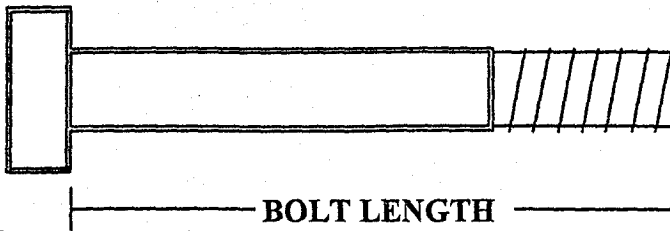
1. Inspect equipment daily. Tighten all loose connections and replace worn parts immediately. Failure to do so may result in serious injury.
2. Do not allow minors or children to play on or around this equipment.
3. Exercise with care to avoid injury.
4. If unsure of proper use of equipment, call your local Parabody distributor or call the Parabody customer service department at (800) 328-9714.
5. Consult a physician before beginning any exercise program.

## Tools Required for Assembly

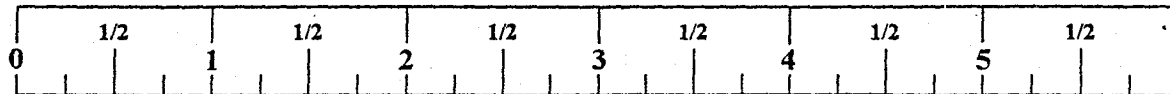
- \* 3/4" wrench
- \* Ratchet with 3/4" and 9/16" sockets
- \* Rubber Mallet or Hammer

## Bolt Length Ruler

**NOTE: BOLT LENGTH IS MEASURED FROM THE UNDERSIDE OF THE HEAD OF THE BOLT.**



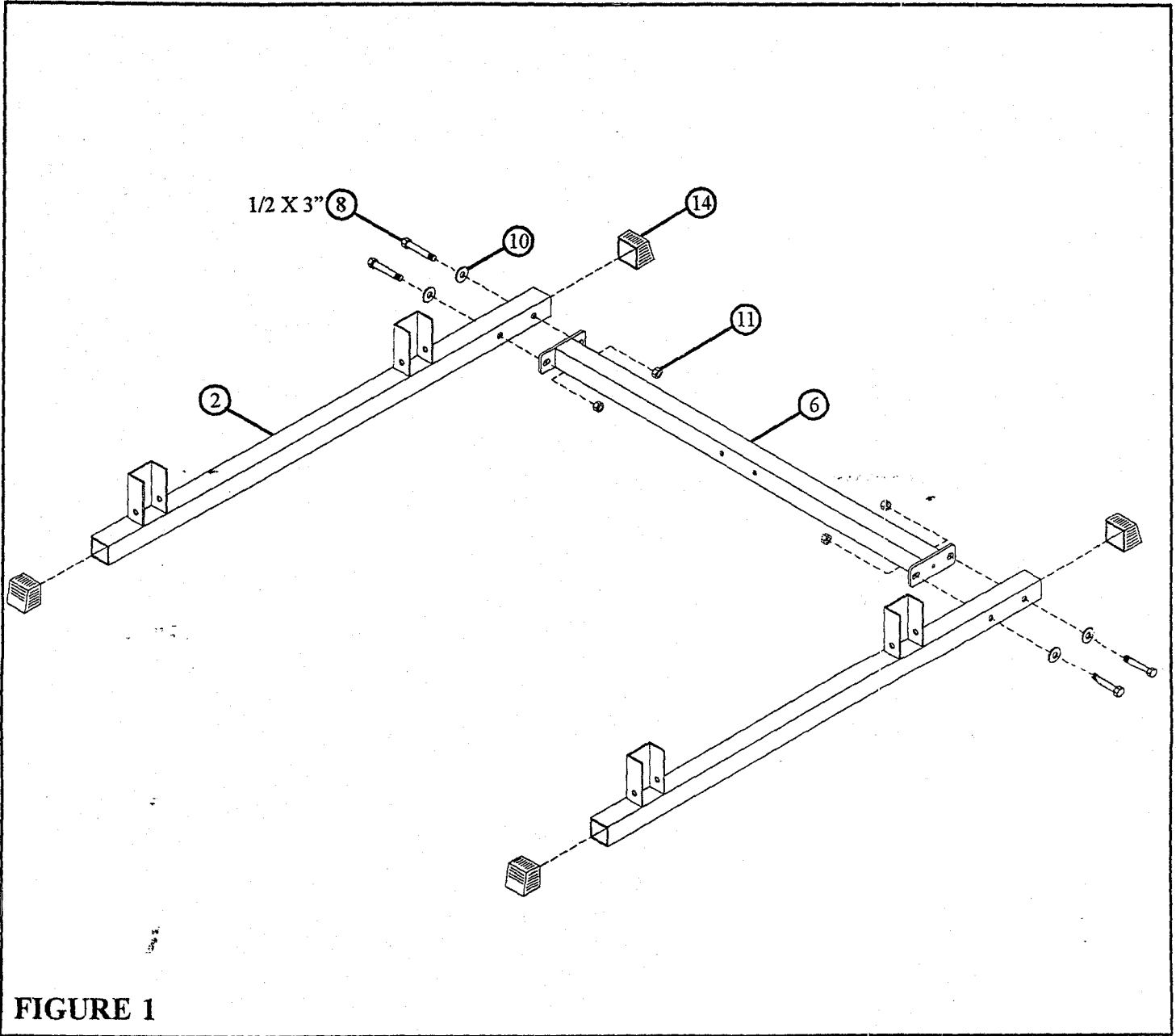
**BOLT LENGTH RULER:**



# PARTS LIST

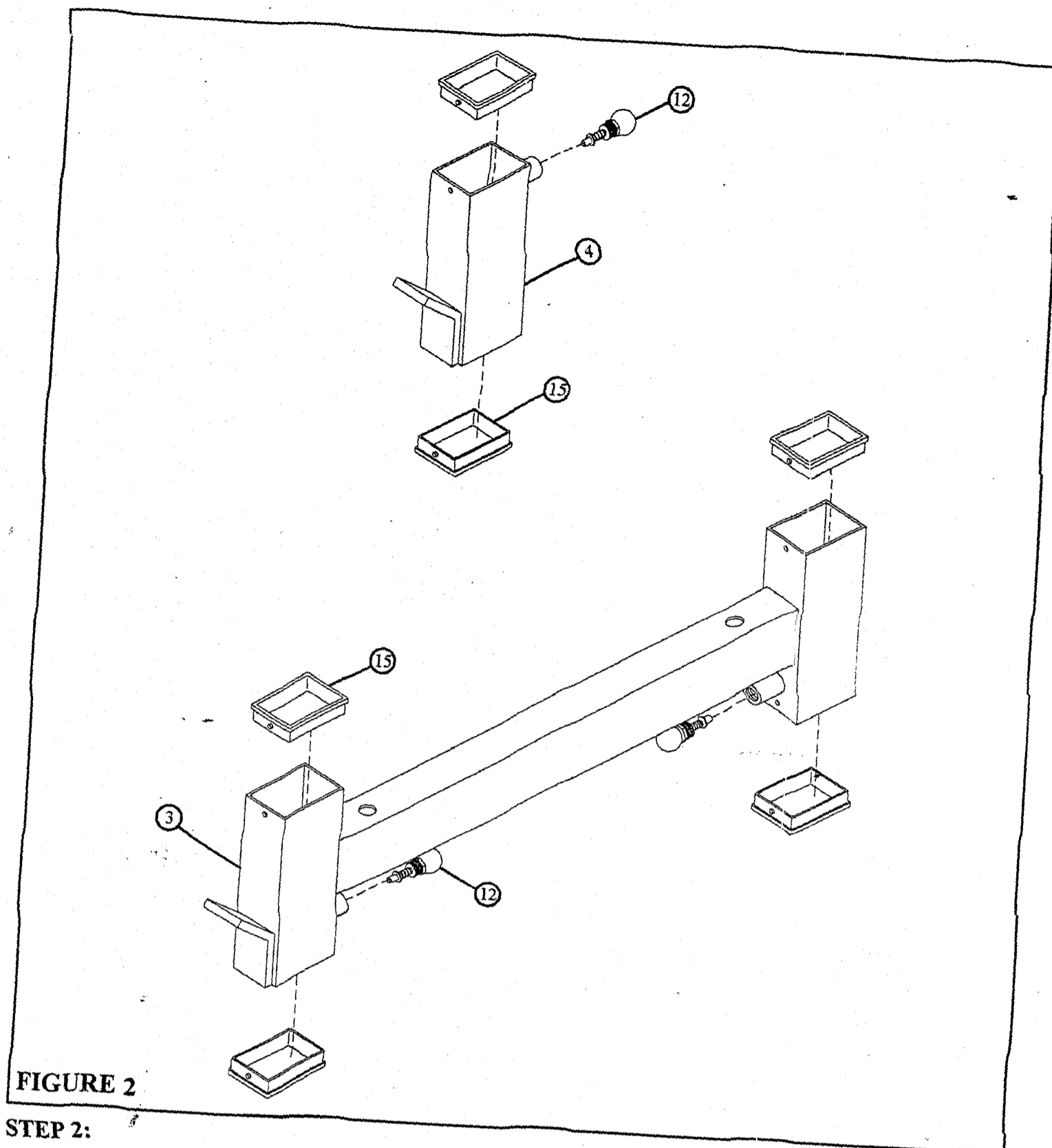
KEY	PART#	DESCRIPTION	QTY
1	6641503	UPRIGHT	2
2	6641802	UPRIGHT BASE	2
3	6605702	SAFETY RAIL	2
4	6605802	BAR SUPPORT	2
5	6605902	CHIN BAR	1
6	6606002	LOWER CONNECTOR	1
7	6606102	UPPER CONNECTOR	1
8	3102910	1/2 X 3" BOLT	12

KEY	PART#	DESCRIPTION	QTY
9	3102917	1/2 X 4" BOLT	4
10	3102502	1/2" WASHER	20
11	3102801	1/2" LOCK NUT	14
12	6606801	SPRING PIN ASSEMBLY	6
13	6405201	2" SQ. END CAP	4
14	6467001	2" SQ. COVER CAP	4
15	6590801	3 X 2" INSERT GUIDE	12



**STEP 1:**

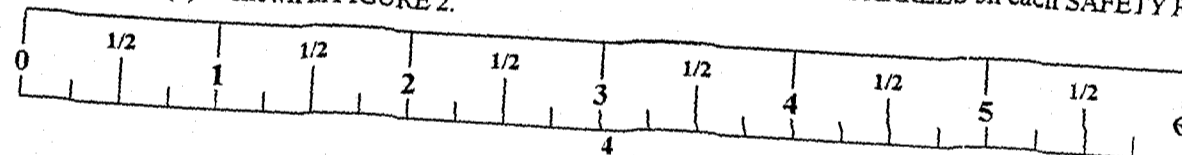
- Slide four 2" SQ. COVER CAPS (14) over the ends of each UPRIGHT BASE (2) as shown in FIGURE 1.
- **LOOSELY** assemble the LOWER CONNECTOR (6) between each UPRIGHT BASE (2) using four 1/2 X 3" BOLTS (8), four 1/2" WASHERS (10), and four 1/2" LOCK NUTS (11). See FIGURE 1.

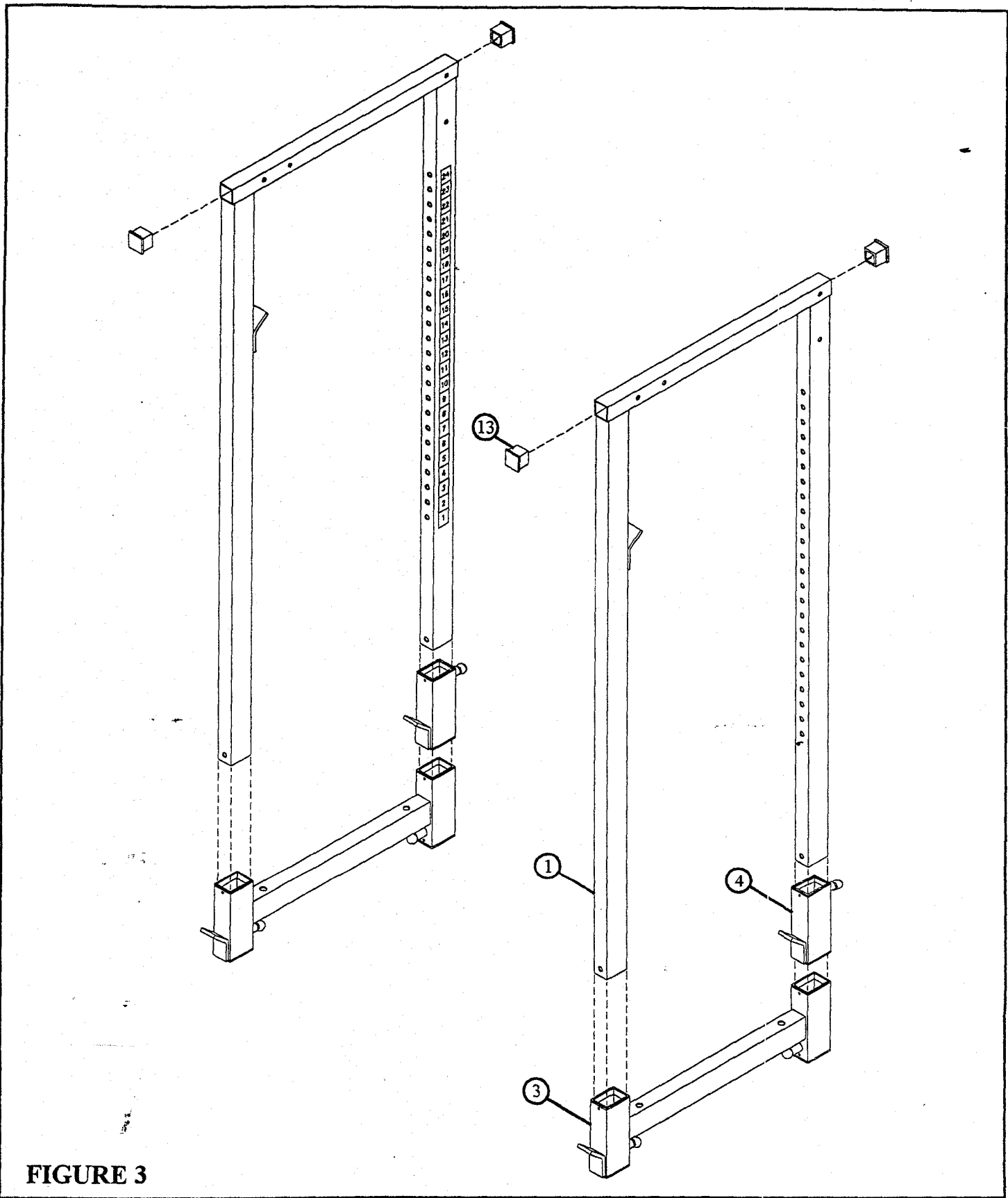


**FIGURE 2**

**STEP 2:**

- Insert twelve 3 X 2" INSERT GUIDES (15) into the ends of each SAFETY RAIL (3) and BAR SUPPORT (4) as shown in FIGURE 2. (NOTE: Make sure the INSERT GUIDES (15) snap into the holes of the weldments.)
- SECURELY assemble the six SPRING PIN ASSEMBLIES (12) to the SPRING PIN BARRELS on each SAFETY RAIL (3) and each BAR SUPPORT (4) as shown in FIGURE 2.

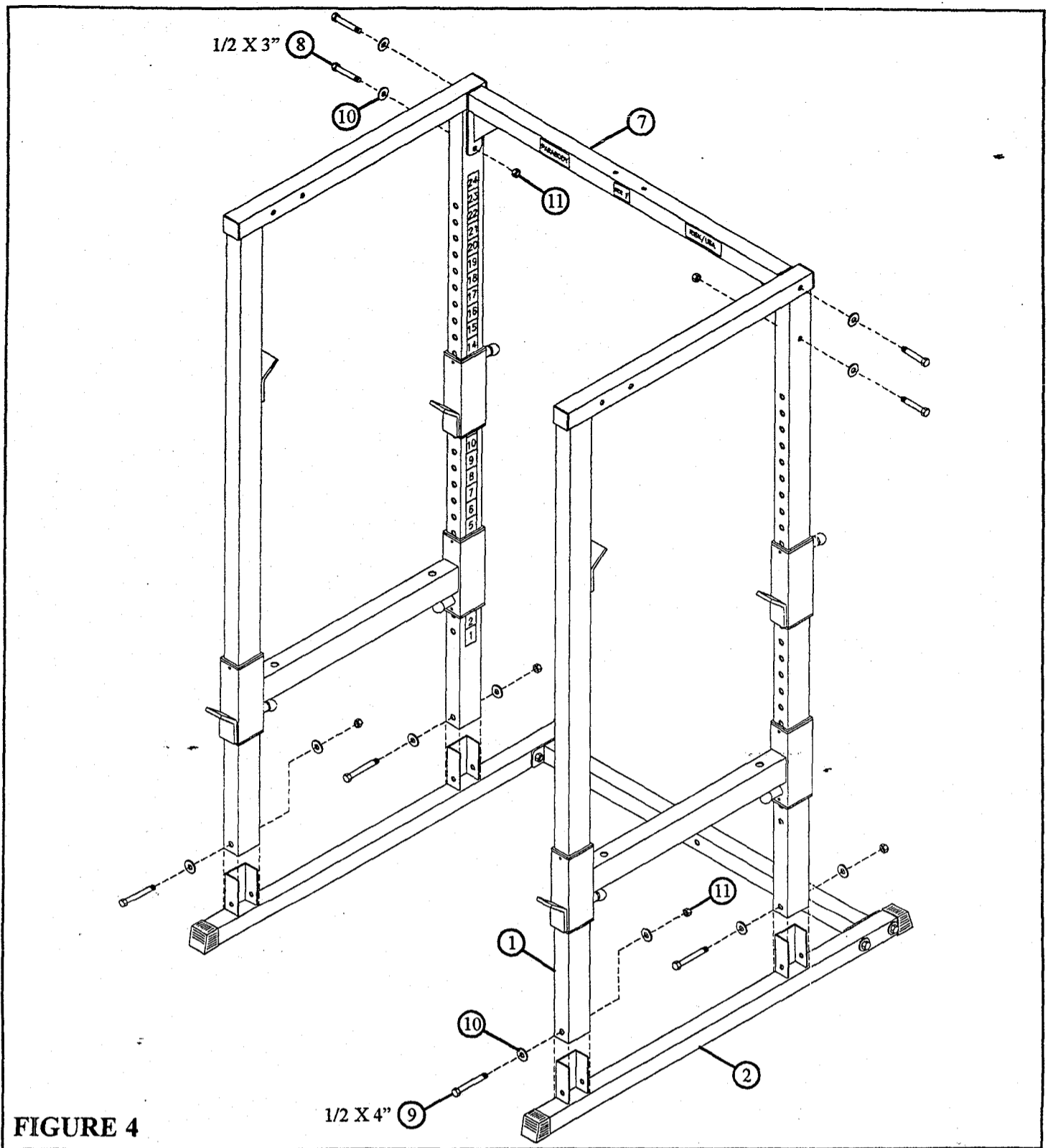




**FIGURE 3**

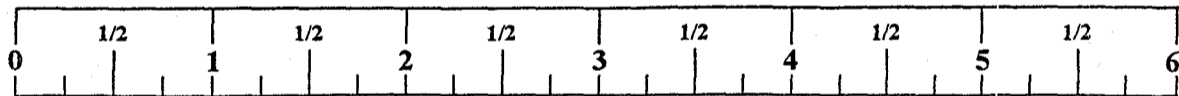
**STEP 3**

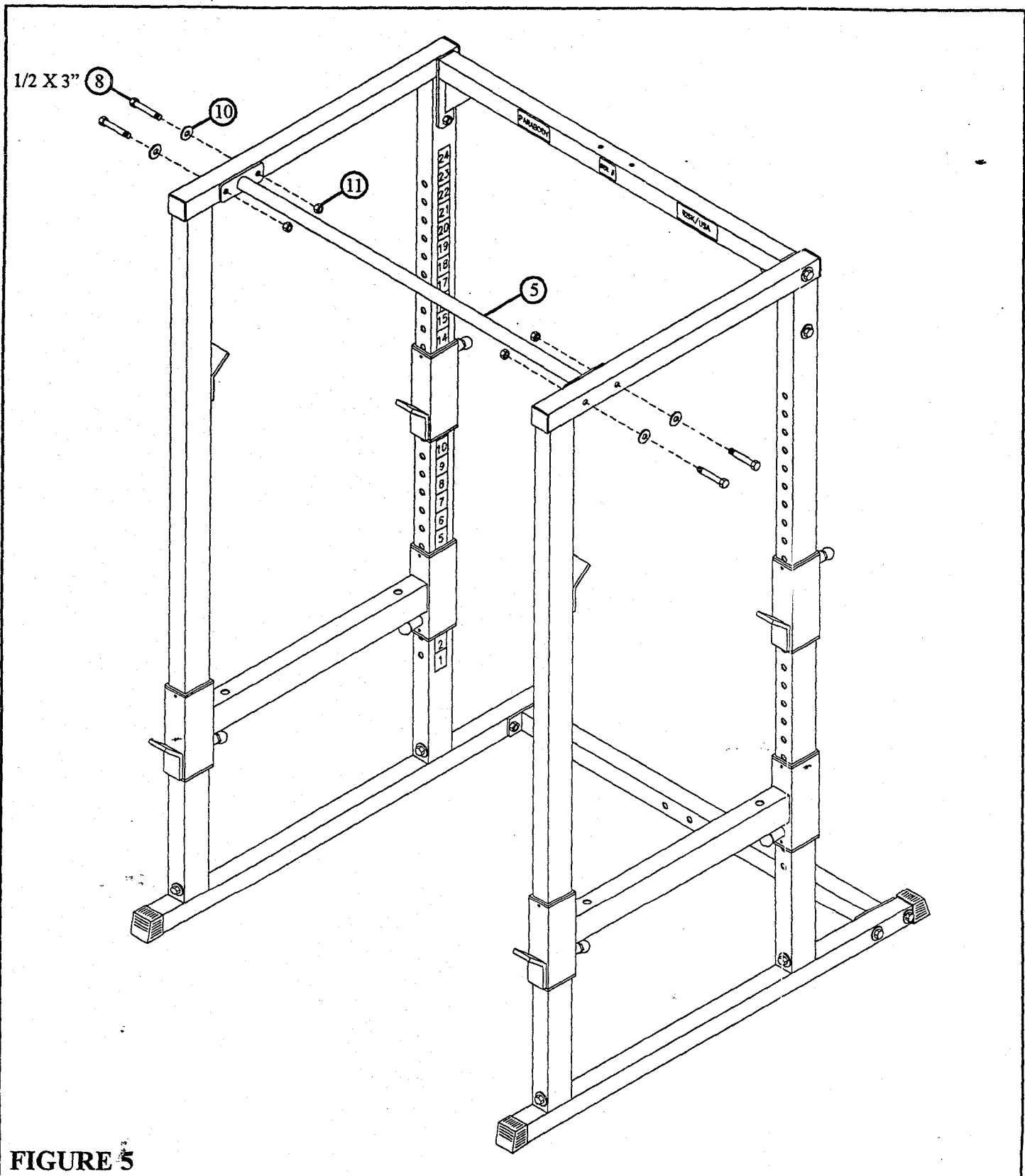
- Insert four 2" SQ. END CAPS (13) into the ends of the UPRIGHTS (1) as shown in FIGURE 3.
- Slide one BAR SUPPORT (4) and one SAFETY RAIL (3) (IN THAT ORDER) onto each UPRIGHT (1). Pull back on the SPRING PIN ASSEMBLIES until they pop into holes.



**STEP 4:**

- **LOOSELY** assemble each UPRIGHT (1) to the UPRIGHT BASE (2) using four 1/2 X 4" BOLTS (9), eight 1/2" WASHERS (10), and four 1/2" LOCK NUTS (11). See FIGURE 4.
- **LOOSELY** assemble the UPPER CONNECTOR (7) using four 1/2 X 3" BOLTS (8), four 1/2" WASHERS (10), and two 1/2" LOCK NUTS (11). See FIGURE 4.





**FIGURE 5**

**STEP 5:**

- **LOOSELY** assemble the CHIN BAR (5) using four 1/2 X 3" BOLTS (8), four 1/2" WASHERS (10), and four 1/2" LOCK NUTS (11). See FIGURE 5.

When all components are assembled, **SECURELY** tighten all bolt connections.

**THIS CONCLUDES THE ASSEMBLY OF THE 843102 POWER RACK.**