



Serious Steel

821104 ROMAN CHAIR ASSEMBLY INSTRUCTIONS

- **THANK YOU** for purchasing the 821 ROMAN CHAIR
- **PLEASE** read these instructions thoroughly and keep them for future reference.
- **TOOLS REQUIRED:** Ratchet, 9/16", 3/4" Socket and 9/16", 3/4" Wrench.
- **IF** you have any problem in the assembly or use of this product, please contact the **PARABODY** Customer Service Department at 1-800-328-9714.

THERE IS A RISK ASSUMED BY INDIVIDUALS WHO USE THIS TYPE OF EQUIPMENT. TO MINIMIZE RISK, PLEASE FOLLOW THESE RULES:

1. Consult your physician before beginning any exercise program.
2. Inspect equipment daily. Tighten all loose connections and replace worn parts immediately. Failure to do so may result in serious injury.
3. Do not allow minors or children to play on or around this equipment.
4. Exercise with care to avoid injury.
5. If unsure of proper use of equipment, call your local ParaBody distributor or call the ParaBody customer service department at 1-800-328-9714.

ParaBody, Incorporated
14150 Sunfish Lake Boulevard
Ramsey, MN 55303
1-800-328-9714

PARTS LIST: *PLEASE IDENTIFY ALL PARTS BEFORE BEGINNING ASSEMBLY*****

ITEM	PART #	DESCRIPTION	QTY
1.	6588303	WLDMT, HIP PAD SUPPORT WHT	1.
2.	6588503	WLDMT, CROSS BRACE WHT	1.
3.	6588702	WLDMT, ROLLER PAD SUPPORT BLK	1.
4.	6588903	WLDMT, FRONT UPRIGHT WHT	1.
5.	6589103	WLDMT, REAR UPRIGHT WHT	1.
6.	6589302	PAD ASSY, 9-1/2 X 9-1/2	2.
7.	6511703	TUBE, 2 SQ 14GA X 24 WHT	2.
8.	6194601	ROLLER PAD, 3/4 LD. X 4 O.D. X 7	2.

HARDWARE LIST: *PLEASE SORT HARDWARE BEFORE BEGINNING ASSEMBLY*****

ITEM	PART #	DESCRIPTION	QTY
1.	3102909	BOLT, HHG2 3/8-16 X 1	5.
2.	3102904	BOLT, HHG2 3/8-16 X 3	2.
3.	3102910	BOLT, HHG2 1/2-13 X 3	8.
4.	3102802	NUT, NYLOCK 3/8-16	3.
5.	3102601	WASHER, LOCK 3/8 ID	4.
6.	3102501	WASHER, FLAT 3/8 ID	10.
7.	3102502	WASHER, FLAT 1/2 ID	8.
8.	3102801	NUT, NYLOCK 1/2-13	8.
9.	6467001	CAP, COVER 2SQ PARABODY LOGO	4.
10.	6692601	CAP, END 3 X 2 10-14GA	1.
11.	3105401	COLLAR, STARLOCK 3/4 LD.	2.
12.	3103102	GRIP, 1 X 8 CLOSED END	2.
13.	6590801	INSERT GUIDE, 3 X 2	2.
14.	6412001	ASSY, SPRING PIN 3/8 DIA	1.
15.	6405201	CAP, END 2 SQ 10-14GA	2.

NOTE: BOLT LENGTH IS MEASURED FROM THE UNDERSIDE OF THE HEAD OF THE BOLT.

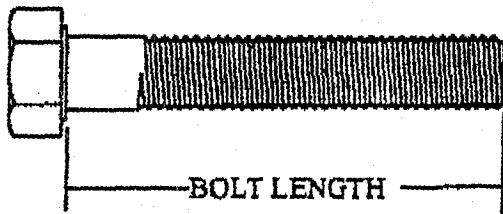

BOLT LENGTH RULER:



1. Insert four (4) 2 IN. SQ. COVER CAPS onto the ends of the BASE TUBES as shown on drawing.
2. SECURELY assemble the BASE TUBES to the FRONT and REAR UPRIGHTS as shown on drawing using four (4) 1/2 X 3 IN. BOLTS, four (4) 1/2 IN. FLAT WASHERS and four (4) 1/2 IN. LOCK NUTS.
3. SECURELY assemble the CROSS BRACE between the FRONT and REAR UPRIGHTS as shown on drawing using four (4) 1/2 X 3 IN. BOLTS, four (4) 1/2 IN. FLAT WASHERS and four (4) 1/2 IN. LOCK NUTS.
4. SECURELY assemble the HIP PAD SUPPORT to the FRONT UPRIGHT as shown on drawing using two (2) 3/8 X 3 IN. BOLTS, four (4) 3/8 IN. FLAT WASHERS and two (2) 3/8 IN. LOCK NUTS.
5. SECURELY assemble the PADS to the HIP PAD SUPPORT as shown on drawing using four (4) 3/8 X 1 IN. BOLTS, four (4) 3/8 IN. FLAT WASHERS and four (4) 3/8 IN. LOCK WASHERS.
6. Insert two (2) 3 X 2 INSERT GUIDES into each end of the ROLLER PAD SUPPORT as shown in DETAIL A
7. SECURELY assemble the SPRING PIN ASSEMBLY to the ROLLER PAD SUPPORT as shown in DETAIL A

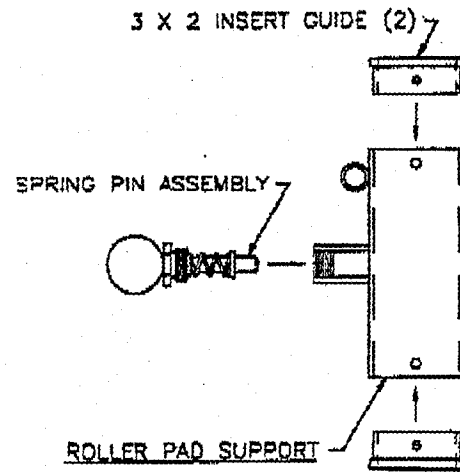

DETAIL A

8. CAREFULLY slide the ROLLER PAD SUPPORT over the REAR UPRIGHT FRAME as shown on drawing.
9. SECURELY assemble one (1) 3/8 X 1 IN. BOLT, two (2) 3/8 IN. FLAT WASHERS and one (1) 3/8 IN. LOCK NUT into top hole of REAR UPRIGHT.
10. INSERT the one (1) 3 X 2 IN. END CAP into top of REAR UPRIGHT.
11. SLIDE the two (2) ROLLER PADS onto the ROLLER PAD SUPPORT and INSERT the two (2) 3/4 IN. I.D. STARLOCK COLLARS into the tube ends as shown on drawing.
12. SLIDE the two (2) 1 X 8 IN. GRIPS onto the HIP PAD SUPPORT tubes as shown on drawing. (Using water will help slide them on)
13. INSERT the two (2) 2 IN. SQ END CAPS into HIP PAD SUPPORT tube ends as shown on drawing.

NO.	DESCRIPTION
1	AS SHOWN

REVISIONS			
REV	DESCRIPTION	DATE	BY
A	ADD INSERT CRUISES	2/72	MMH
B	CHG TO STARLOCK	2/78	TR

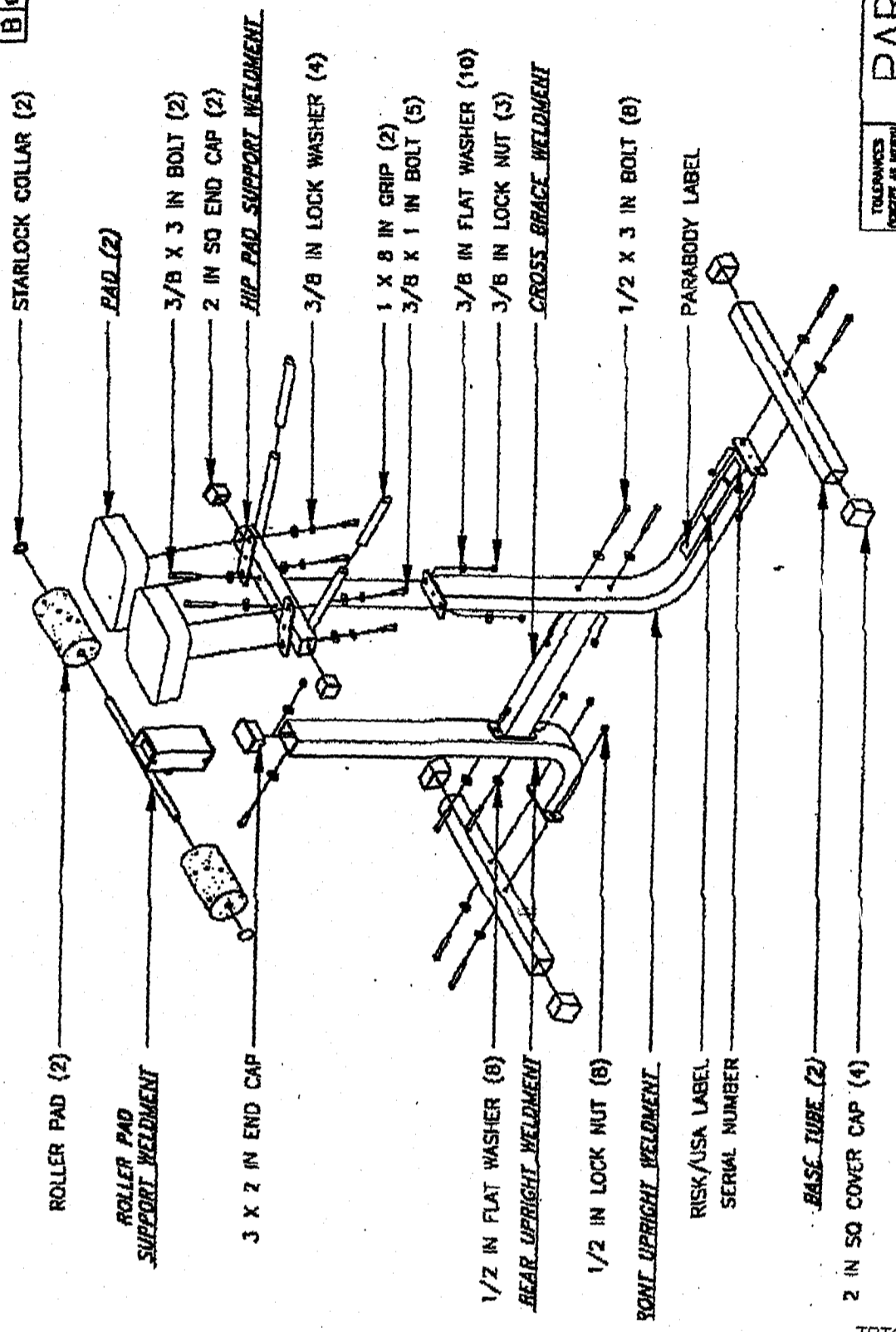

TOTAL P.04

TOLERANCES (UNLESS OTHERWISE SPECIFIED)	
FRACTIONS	± .005
DECIMALS	± .01
ANGLES	± 1'
PARABODY, INC. RAMSEY, MINNESOTA	
TRD	ASSY INST, B21104
SCALE	1/13
SHEET	1 OF 1
DATE	66002