

**493 BODYSMITH PROSYSTEM ASSEMBLY INSTRUCTIONS**

**!!! WARNING !!!**

**MAKE SURE SNAP HOOKS ARE FASTENED BEFORE DOING EXERCISES**

**!!! WARNING !!!**

**DO NOT OPERATE THIS MACHINE WITH LAT BAR OFF SAFETY HOOKS EXCEPT DURING HIGH PULLEY EXERCISES**

**!!! WARNING !!!**

**THE LAT BAR IS NOT TO BE USED FOR PULL-UPS**

**!!! NOTE !!!**

**PLACE LOW ROW BAR IN LOW ROW BAR HOLDERS WHEN NOT IN USE**

**PARABODY INC.**

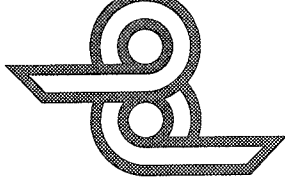

**BODYSMITH PROSYSTEM MAIN UNIT  
493**

**PRODUCT ASSEMBLY  
INSTRUCTION SHEETS**

**TOOLS REQUIRED FOR ASSEMBLY**

- 9/16 INCH SOCKET
- ADJUSTABLE WRENCH
- RUBBER MALLET or HAMMER

**REVISION: D**

**If you experience any problem with the assembly of this product, please contact your dealer or your PARABODY Customer Service Representative at:**

**1-800-328-9714**

## 493 BODYSMITH PROSYSTEM ASSEMBLY PARTS LIST

### SORT AND COUNT ALL PARTS BEFORE BEGINNING ASSEMBLY

#### HARDWARE:

ITEM	NAME/DESCRIPTION	QTY
1.	3/8 X 3-1/4 IN. BOLT	2
2.	3/8 X 3 IN. BOLT	14
3.	3/8 X 2-3/4 IN. BOLT	1
4.	3/8 X 2 IN. BOLT	2
5.	3/8 X 1-3/4 IN. BOLT	2
6.	3/8 IN. WASHER	25
7.	3/8 IN. LOCK WASHER	18
8.	3/8 IN. NUT	18
9.	3/8 IN. LOW HEIGHT LOCK NUT	3
10.	5/16 IN. SNAP HOOK	4
11.	STAR LOCK COLLAR	2
12.	1-1/4 IN. SQ. RUBBER BUMPER	1
13.	CARRIAGE GUIDE	8
14.	2 IN. SQ. END CAP	7
15.	ROD END COVER (1/4 X 5-3/8)	2
16.	1 X 8 IN. GRIP	4
17.	3/4 X 2 IN. PARAGLIDE STRIP	1
18.	1-1/2 X 2 IN. PARAGLIDE STRIP (9 PER)	1
19.	1/2 IN. LG. PULLEY SPACER	6

NOTE: BOLT LENGTH IS MEASURED FROM THE UNDERSIDE OF THE HEAD OF THE BOLT.

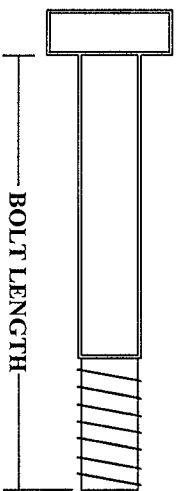

BOLT LENGTH RULER:



## 493 BODYSMITH PROSYSTEM ASSEMBLY INSTRUCTIONS

25. To install SECONDARY CABLE (PB2559-1), start by inserting the end of the CABLE, WITHOUT the WHITE BALL under the FRONT PULLEY in the LOW ROW PULLEY HOUSING on the MAIN UPRIGHT. (REMOVE PULLEY FOR EASE OF INSTALLATION)
- Push the CABLE under the FRONT PULLEY and through the HOLE of the MAIN UPRIGHT to the PULLEY on the UPRIGHT BRACE of the MAIN UPRIGHT. Pull the CABLE until the WHITE BALL stops against the FRONT PULLEY and the LOW ROW PULLEY HOUSING.
- Pull the CABLE around the BRACE PULLEY and up to the SECOND PULLEY on the PULLEY BLOCK SYSTEM. (NOTE: THE CABLE MUST BE ROUTED AROUND THE SECOND PULLEY FROM THE REAR TO THE FRONT)
- Pull the CABLE around the SECOND PULLEY of the PULLEY BLOCK SYSTEM and down to the first HOLE above the larger set of HOLES on the MAIN UPRIGHT. Attach the end of the CABLE to the MAIN UPRIGHT, using one (1) 3/8 X 2-3/4 IN. BOLT, one (1) 3/8 IN. WASHER, one (1) 3/8 IN. LOCK WASHER and one (1) 3/8 IN. NUT. (SEE DETAIL F)
- See CABLE ROUTING DIAGRAM (DETAIL A) for help in completing STEP 24.
26. TIGHTEN ALL LOOSE PULLEY CONNECTIONS MADE TO THIS POINT.
27. Slide four (4) 1 X 8 IN. GRIPS over each end of both the LAT BAR, and the LOW ROW BAR. (NOTE: IF A LUBRICANT IS REQUIRED, RUBBING ALCOHOL THOROUGHLY COATING THE INSIDE OF THE GRIP IS THE BEST MATERIAL TO USE) (SEE DETAIL A AND B)
28. Attach the LAT BAR to the PRIMARY CABLE, and the LOW ROW BAR to the SECONDARY CABLE, by using two (2) 5/16 IN. SNAP HOOK. (SEE DETAIL A AND B)
29. To adjust the LOW ROW BAR. Remove the LOW ROW BAR from the 5/16 IN. SNAP HOOK on the SECONDARY CABLE, and attach the 24 LINK CHAIN. Attach another 5/16 IN. SNAP HOOK to the LOW ROW BAR and adjust it to the desired CHAIN LINK. (SEE DETAIL B)
30. Attach two (2) sets of UPRIGHT LABELS (designated #1 to #21) to the inside surface of both FRONT UPRIGHTS. (SEE DRAWING)
31. To use the LOW ROW FOOT BRACE, slip it over the BASE LEGS, and up against the UPRIGHTS of the FRONT UPRIGHTS. (SEE DRAWING)

## 493 BODYSMITH PROSYSTEM ASSEMBLY INSTRUCTIONS

17. Attach one (1) 3/4 X 2 IN. PARAGLIDE STRIP and one (1) 1-1/2 X 2 IN. PARAGLIDE STRIP to the ADJUSTABLE KNEE SUPPORT as shown in (DETAIL E) using the following steps:

- A. Thoroughly clean all surfaces where the PARAGLIDE STRIPS are to be attached.
- B. Remove the paper backing from the PARAGLIDE STRIPS and firmly apply them to the shown surfaces.

18. Assemble two (2) ROLLER PADS to the ADJUSTABLE KNEE SUPPORT, using one (1) ROLLER PAD SHAFT, and two (2) STAR LOCK COLLARS.

19. Insert one (1) 2 IN. SQ. END CAP into the front end of the ADJUSTABLE KNEE SUPPORT.

20. To use the ADJUSTABLE KNEE SUPPORT, turn the KNEE SUPPORT TUBE so that the ROLLER PADS are vertical. Insert the pin into the desired hole, and rotate clockwise until locked. (SEE DRAWING)

21. Attach two (2) 13-1/2 IN. RUBBER PADS to the tops of the SAFETY RAILS as shown on drawing.

22. Attach eight (8) 1-1/2 X 2 PARAGLIDE STRIPS to the BAR HOLDERS, and SAFETY RAILS as shown in (DETAIL F) using the following steps:

- A. Thoroughly clean all surfaces where the PARAGLIDE STRIPS are to be attached.
- B. Remove the paper backing from the PARAGLIDE STRIPS and firmly apply them to all shown surfaces.

23. To use the BAR HOLDERS, and SAFETY RAILS follow the same procedure as in STEP 20.

**NOTE: BEFORE PROCEEDING WITH CABLE INSTALLATION, UNRAVEL CABLE, AND REMOVE AS MUCH SPIRALING AS POSSIBLE.**

24. To install the PRIMARY CABLE (PB2827-1), start by inserting the end of the CABLE, WITHOUT the WHITE BALL between the TOP PULLEY and the LAT BAR HOLDER on the PULLEY MOUNT FLATS. (REMOVE PULLEY FOR EASE OF INSTALLATION)

- Pull CABLE over TOP PULLEY until the WHITE BALL stops against the PULLEY and the LAT BAR HOLDER.
- Pull CABLE over and down the SECOND PULLEY of the PULLEY MOUNT FLATS. Run the CABLE around one of the PULLEYS of the PULLEY BLOCK SYSTEM and up to the THIRD PULLEY of the PULLEY MOUNT FLATS.
- Pull CABLE over and down the THIRD PULLEY, to the WEIGHT CARRIAGE. Attach the CABLE to the WEIGHT CARRIAGE, using one (1) 5/16 IN. SNAP HOOK. (SEE DETAIL C)
- See CABLE ROUTING DIAGRAM (DETAIL A) for help in completing STEP 23.

**NOTE: IF THIS UNIT WILL BE ASSEMBLED WITH OPTIONAL PEC DEC, STOP HERE AND REFER TO THE PEC DEC ASSEMBLY INSTRUCTIONS. COMPLETE STEPS #2 THRU # 18. WHEN THIS IS COMPLETED, SKIP STEP #24, AND CONTINUE ON TO STEP #25 OF THE MAIN UNIT INSTRUCTIONS.**

## 493 BODYSMITH PROSYSTEM ASSEMBLY PARTS LIST

### WELDMENTS/PARTS:

ITEM	NAME/DESCRIPTION	QTY
1.	MAIN UPRIGHT ..... (6283901)	1
2.	WEIGHT CARRIAGE ..... (6250501)	1
3.	TOP UPRIGHT SUPPORT ..... (6250901)	1
4.	BOTTOM UPRIGHT SUPPORT ..... (6251101)	1
5.	FRONT UPRIGHT ..... (6283601)	2
6.	ADJUSTABLE KNEE SUPPORT ..... (6283001)	1
7.	LAT BAR HOLDER ..... (6251401)	1
8.	BAR HOLDER ..... (6250301)	2
9.	LAT BAR ..... (6275301)	1
10.	LOW ROW BAR ..... (6274401)	1
11.	PULLEY MOUNT FLAT ..... (6283801)	2
12.	PAINTED CONNECTOR ..... (6013702)	2
13.	SAFETY RAILS ..... (6283401)	2
14.	LOW ROW FOOT BRACE ..... (6257101)	1
15.	PRIMARY CABLE ..... (6282701)	1
16.	SECONDARY CABLE ..... (6255901)	1
17.	ROLLER PAD ..... (6194601)	2
18.	ROLLER PAD SHAFT ..... (6125101)	1
19.	24 LINK CHAIN ..... (6075905)	1
20.	UPRIGHT LABELS ..... (6189501)	2
21.	13-1/2 IN. RUBBER PAD ..... (6387101)	2
22.	3-1/2 O.D. X 1 IN. BUSHING PULLEY ..... (3116201)	6
23.	4-1/2 O.D. X 1 IN. BUSHING PULLEY ..... (3116101)	1

## 493 BODYSMITH PROSYSTEM ASSEMBLY INSTRUCTIONS

### IMPORTANT:

- THE BODYSMITH PROSYSTEM MUST BE ASSEMBLED ON A FLAT LEVEL SURFACE TO ASSURE ITS PROPER FUNCTION.
- PARABODY, INC. STRONGLY RECOMMENDS THAT THIS PRODUCT BE ASSEMBLED BY TWO PERSONS TO AVOID POSSIBLE INJURY.

### \*\*\* IMPORTANT \*\*\*

## KEEP ALL LOOSE FRAME CONNECTIONS

## LOOSE UNTIL INSTRUCTED IN THE ASSEMBLY STEP SEQUENCES TO SECURELY TIGHTEN

1. Insert six (6) 2 IN. SQ. END CAP into both FRONT UPRIGHTS. Two (2) into each end of the BASE LEG, and one (1) into the TOP end of the UPRIGHT.
2. LOOSELY assemble the BOTTOM UPRIGHT SUPPORT to both FRONT UPRIGHTS, using four (4) 3/8 X 3 IN. BOLTS, eight (8) 3/8 IN. WASHERS, four (4) 3/8 IN. LOCK WASHERS, and four (4) 3/8 IN. NUTS. (NOTE: THE LOW ROW BAR HOLDERS ON THE BOTTOM UPRIGHT SUPPORT SHOULD BE UNDERNEATH) (SEE DRAWING)
3. LOOSELY assemble the TOP UPRIGHT SUPPORT to both FRONT UPRIGHTS, using two (2) 3/8 X 3 IN. BOLTS, four (4) 3/8 IN. WASHERS, two (2) 3/8 IN. LOCK WASHERS, and two (2) 3/8 IN. NUTS. (NOTE: MAKE SURE THAT THE TOP UPRIGHT SUPPORT IS FLUSH WITH THE TOP OF THE FRONT UPRIGHT) (SEE DRAWING)
4. LOOSELY assemble the MAIN UPRIGHT to the TOP and BOTTOM UPRIGHT SUPPORT, using four (4) 3/8 X 3 IN. BOLTS, eight (8) 3/8 IN. WASHERS, four (4) 3/8 IN. LOCK WASHERS, and four (4) 3/8 IN. NUTS. (SEE DRAWING)
5. Attach eight (8) CARRIAGE GUIDES to the WEIGHT CARRIAGE as shown in (DETAIL D) using the following steps:
  - A. Thoroughly clean all inside surfaces where the CARRIAGE GUIDES are to be attached.
  - B. Remove the paper backing from the CARRIAGE GUIDES and firmly apply them to all shown surfaces (8 places)

## 493 BODYSMITH PROSYSTEM ASSEMBLY INSTRUCTIONS

6. Attach one (1) 1-1/4 SQ. RUBBER BUMPER to the CENTER of the CARRIAGE STOP on the WEIGHT CARRIAGE.
7. Slide WEIGHT CARRIAGE down over the REAR UPRIGHT of the MAIN UPRIGHT. (NOTE: MAKE SURE THAT THE WEIGHT PEG ON THE WEIGHT CARRIAGE IS FACING TOWARDS THE FRONT OF THE MACHINE)
8. LOOSELY attach the two (2) PULLEY MOUNT FLATS to the REAR and FRONT UPRIGHTS of the MAIN UPRIGHT, using two (2) 3/8 X 3 IN. BOLTS, two (2) 3/8 IN. LOCK WASHERS, and two (2) 3/8 IN. NUTS. (NOTE: THE HOLE CLOSEST TO THE END ON THE PULLEY MOUNT FLATS SHOULD BE ASSEMBLED TO THE REAR UPRIGHT) (SEE DRAWING)
9. AT THIS TIME TIGHTEN ALL LOOSE FRAME CONNECTIONS MADE TO THIS POINT.
10. LOOSELY attach two (2) 3-1/2 O.D. X 1 IN. BUSHING PULLEY and four (4) 1/2 IN. LG. PULLEY SPACERS (ONE ON EACH SIDE OF THE PULLEYS) between the PULLEY MOUNT FLATS above the WEIGHT CARRIAGE, using two (2) 3/8 X 3 IN. BOLTS, two (2) 3/8 IN. LOCK WASHERS, and two (2) 3/8 IN. NUTS.
11. Slide the two (2) ROD END COVERS over the ends of the LAT BAR HOLDER.
12. Slide the LAT BAR HOLDER over the PULLEY MOUNT FLATS, and LOOSELY assemble in place, using one (1) 3/8 X 3-1/4 BOLT, and one (1) 3/8 IN. LOW HEIGHT LOCK NUT. (NOTE: USE THE SECOND SET OF HOLES IN FROM THE END) (SEE DRAWING)
13. LOOSELY assemble one (1) 3-1/2 O.D. X 1 IN. BUSHING PULLEY, and two (2) 1/2 IN. LG. PULLEY SPACER (ONE ON EACH SIDE OF THE PULLEY) between the PULLEY MOUNT FLATS at the FRONT, using one (1) 3/8 X 3-1/4 IN. BOLTS, one (1) 3/8 IN. LOCK WASHER, and one (1) 3/8 IN. NUT.
14. LOOSELY assemble one (1) 4-1/2 O.D. X 1 IN. BUSHING PULLEY to the PULLEY BRACKET on the UPRIGHT BRACE of the MAIN UPRIGHT, using one (1) 3/8 X 1-3/4 IN. BOLT, one (1) 3/8 IN. LOCK WASHER, and one (1) 3/8 IN. NUT.
15. LOOSELY assemble one (1) 3-1/2 O.D. X 1 IN. BUSHING PULLEY to the LOW ROW PULLEY HOUSING of the MAIN UPRIGHT, using one (1) 3/8 X 1-3/4 IN. BOLT, one (1) 3/8 IN. LOCK WASHER, and one (1) 3/8 IN. NUT.
16. To assemble the PULLEY BLOCK SYSTEM, SECURELY assemble two (2) PAINTED CONNECTORS around two (2) 3-1/2 O.D. X 1 IN. BUSHING PULLEYS, using two (2) 3/8 X 2 IN. BOLTS, four (4) 3/8 IN. WASHERS, and two (2) 3/8 IN. LOW HEIGHT LOCK NUTS. (NOTE: THE HOLES IN THE PAINTED CONNECTOR ARE OVAL, MAKE SURE THAT THE PULLEYS ARE AT THE MAXIMUM WIDTH, SEE DETAIL G)

A	NEW RELEASE		
B	REMOVE CABLE P/N	2187	1/2x1/8

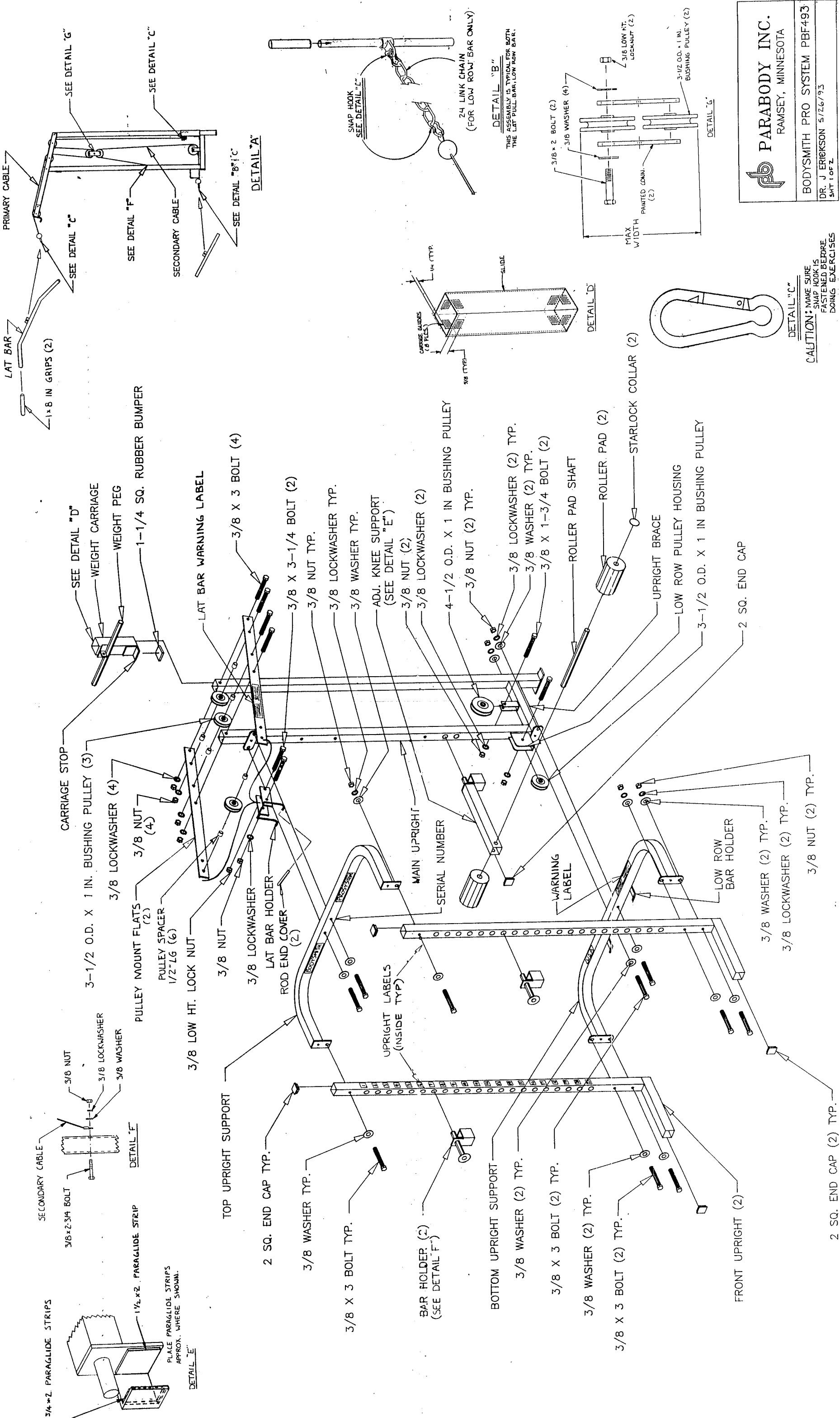

**PARABODY INC.**  
 RAMSEY, MINNESOTA

BODYSMITH PRO SYSTEM PBF493  
 DR. J. ERIKSON 5/26/73  
 SH 1 OF 2

**CAUTION: MAKE SURE SNAP HOOK IS FASTENED BEFORE DOING EXERCISES**

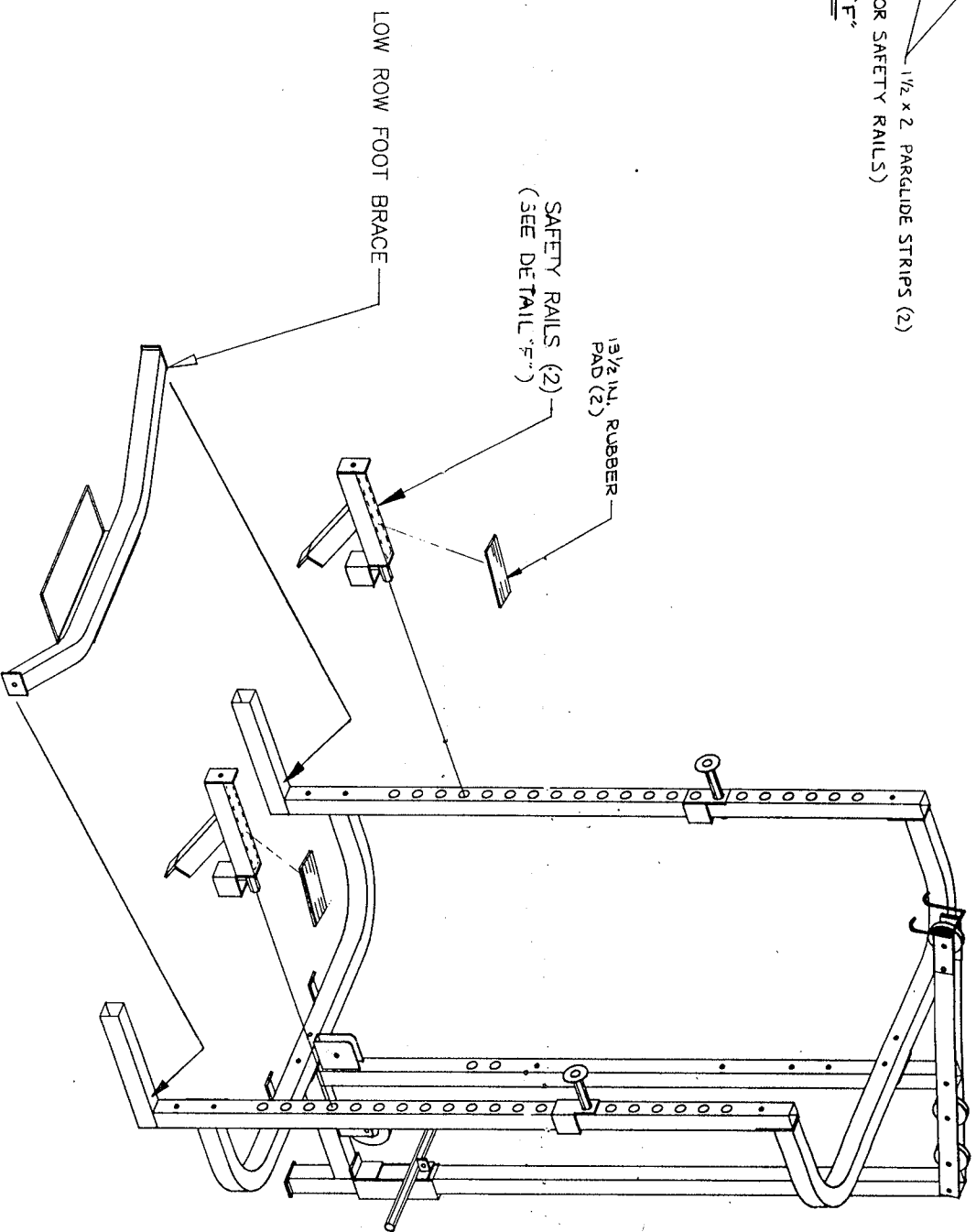
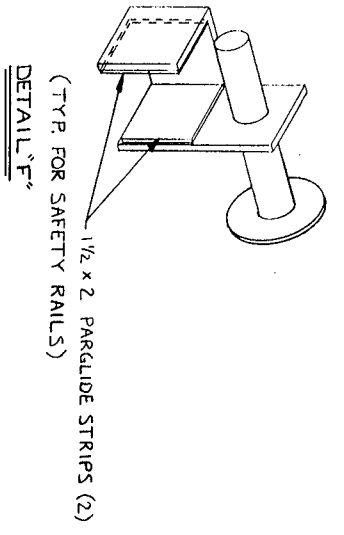

**PARABODY INC.**  
 RAMSEY, MINNESOTA  
 BODYSMITH PRO SYSTEM PBF493  
 DR. J. ERICKSON 5/26/93  
 SHT 2 OF 2