

# *Panther*™

*panthercarts.com*

## **NURSERY PUSH CART MODEL H3035 INSTRUCTION SHEET**



COPYRIGHT © JUNE, 2004 BY GRIZZLY INDUSTRIAL, INC.  
**WARNING: NO PORTION OF THIS MANUAL MAY BE REPRODUCED IN ANY SHAPE  
OR FORM WITHOUT THE WRITTEN APPROVAL OF GRIZZLY INDUSTRIAL, INC.**  
#PC6395 PRINTED IN CHINA

# PARTS INVENTORY

The Model H3035 was carefully packed when it left our warehouse. If you discover this cart is damaged after you have signed for delivery, *please immediately call Customer Service at (570) 546-9663 for advice.*

Save the containers and all packing materials for possible inspection by the carrier or its agent. *Otherwise, filing a freight claim can be difficult.*

When you are completely satisfied with the condition of your shipment, you should inventory the contents.

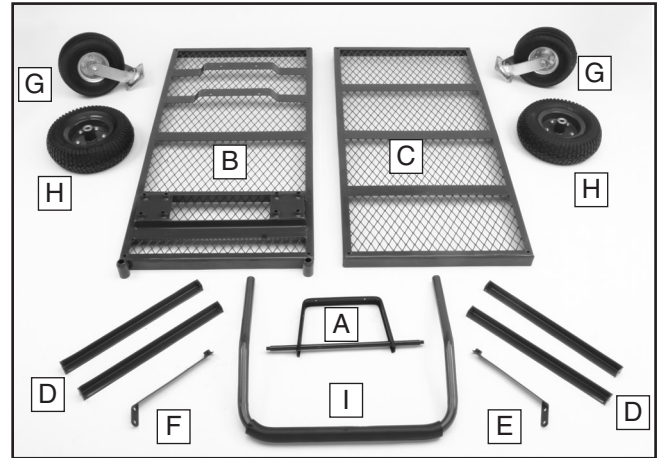

Figure 1. Main contents.

## Inventory (Figure 1)

<b>A.</b>	Axle Bracket .....	1
<b>B.</b>	Bottom Tray .....	1
<b>C.</b>	Top Tray.....	1
<b>D.</b>	Posts.....	4
<b>E.</b>	Axle Brace (R).....	1
<b>F.</b>	Axle Brace (L) .....	1
<b>G.</b>	Swivel Casters.....	2
<b>H.</b>	Wheels .....	2
<b>I.</b>	Handle .....	1
<b>J.</b>	Bolt Bag (not shown).....	1
	—Hex Bolts M8-1.25 x 25 .....	4
	—Hex Nut M8-1.25.....	14
	—Hex Bolts M8-1.25 x 20 .....	6
	—Flat Washers 8mm .....	14
	—Lock Washers 8mm.....	14
	—Hex Bolts M8-1.25 x 40 .....	4
	—Hex Bolts M10-1.5 x 40.....	8
	—Hex Bolts M10-1.5 x 25.....	2
	—Flat Washers 10mm.....	10
	—Hex Nuts M10-1.5 .....	8
	—Lock Washers 10mm.....	10
	—Acorn Nuts M12-1.75.....	2
	—Flat Washers 12mm.....	2

## ! WARNING

Children may climb into plastic bags and suffocate. Keep all plastic bags included in packaging out of the reach of children.

## ! CAUTION

Adult supervision is always required while this wagon is being used by children.

# ASSEMBLY INSTRUCTIONS

1. Attach the swivel casters to the plates on the bottom tray with the M8-1.25 x 25 bolts, washers, lock washers and nuts. NOTE: *Only tighten the bolts finger tight until assembly is complete.*
2. Attach the axle bracket to the rear cross member with the M8-1.25 x 20 bolts, washers, lock washers and nuts.
3. Slide the right and left axle braces over the axle and attach to the adjacent cross-member with the M8-1.25 x 20 bolts, washers, lock washers, and nuts.
4. Slide the wheels on the axle so the valves are facing out. Slide on one 12mm washer and thread an M12-1.75 on the axle to secure the wheel.
5. Turn cart on side and attach the four posts with M8-1.25 x 40 bolts, washers, lock washers and nuts through the bottom of the tray.
6. Set the cart upright and attach the top tray with M8-1.25 x 25 bolts, washers, lock washers and nuts.
7. Slide the handle into the guides on the lower tray and attach the M8-1.25 x 25 bolt, washer and lock washer into the handle through the bottom.
8. Once all parts are assembled and aligned, tighten all of the bolts.

*If you need additional help with this procedure, call our service department at: (570) 546-9663.*

# H3035 Parts Breakdown and List

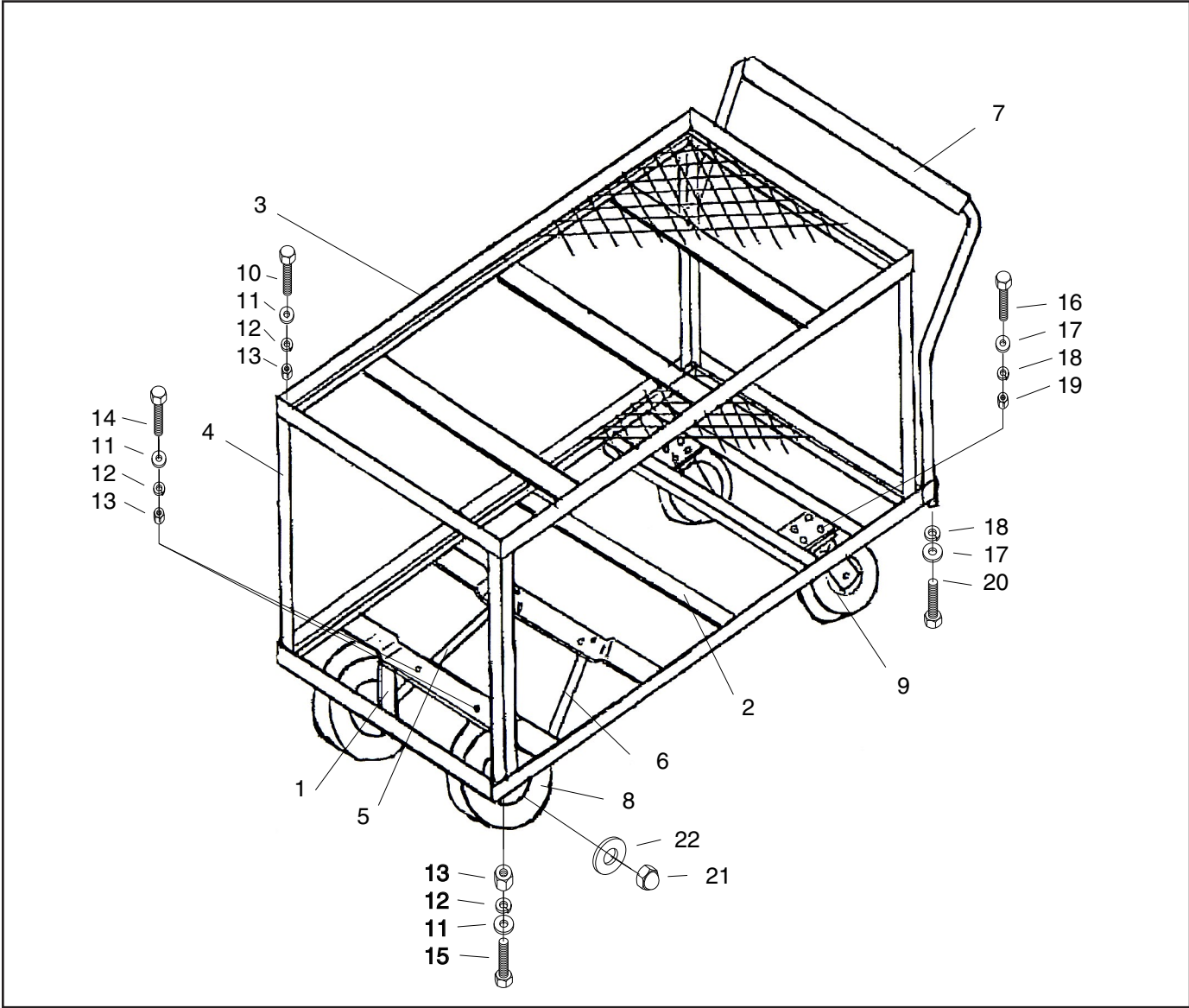

REF	PART #	DESCRIPTION
1	PH3035001	AXLE BRACKET
2	PH3035002	BOTTOM TRAY
3	PH3035003	TOP TRAY
4	PH3035004	POST
5	PH3035005	AXLE BRACE (R)
6	PH3035006	AXLE BRACE (L)
7	PH3035007	HANDLE
8	PH3035008	FIXED WHEEL 13.0 X 5
9	PH3035009	SWIVEL CASTER 4.1 X 3.5
10	PB07M	HEX BOLT M8-1.25 X 25
11	PW01M	FLAT WASHER 8MM

REF	PART #	DESCRIPTION
12	PLW04M	LOCK WASHER 8MM
13	PN03M	HEX NUT M8-1.25
14	PB09M	HEX BOLT M8 X 1.25 X 20
15	PB126M	HEX BOLT M8 X 1.25 X 38
16	PB31M	HEX BOLT M10 X 1.5 X 40
17	PW04M	FLAT WASHER 10MM
18	PLW06M	LOCK WASHER 10MM
19	PN02M	HEX NUT M10-1.5
20	PB32M	HEX BOLT M10-1.5 X 25
21	PN26M	ACORN NUT M12-1.75
22	PW06M	FLAT WASHER 12MM