

ORECK[®] XL[®]

S I M P L Y A M A Z I N G[®]

72191-02 REV B

F R A N Ç A I S

GUIDE D'UTILISATION PAGE 7

E S P A Ñ O L

GUIA DEL USUARIO PAGE 12

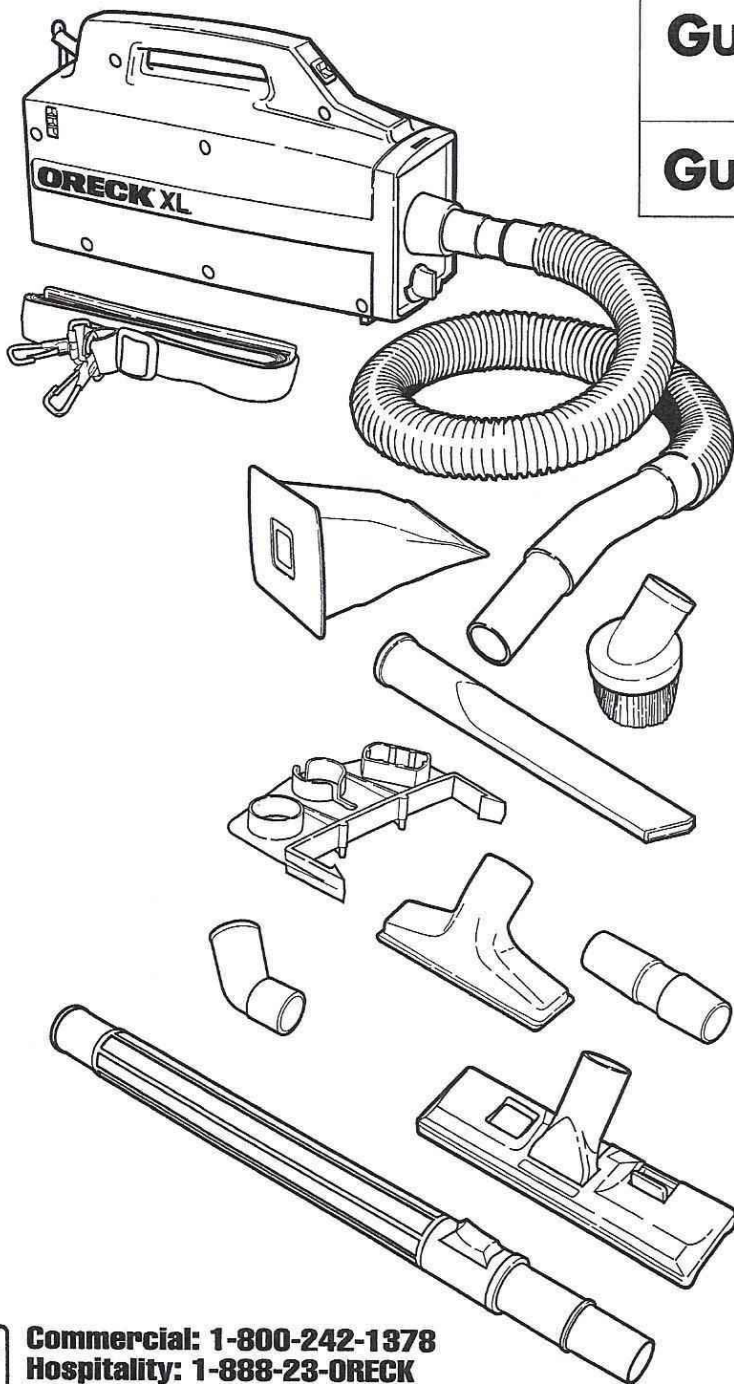

USER'S GUIDE BB900

• IMPORTANT •
SAVE THIS BOOKLET!

Includes:

- Safety Warnings
- Parts List
- Operating Instructions
- Maintenance
- Warranty
- Trouble Diagnosis
- Accessories List



Commercial: 1-800-242-1378
Hospitality: 1-888-23-ORECK
CANADA: 1-866-74-ORECK



WWW.ORECKCOMMERCIAL.COM

**BEFORE OPERATING
CLEANER, READ ALL
INSTRUCTIONS IN THIS
MANUAL CAREFULLY.**

Table of Contents

Safeguards,
Important Safety Instructions page 2

Warranty, Accessory Parts List page 3

Operating, Assembly Instructions . . . page 4

Maintenance & Customer Service,
Troubleshooting Guide page 5

Accessories page 6

Français Guide D'utilisation page 7

Español Guía Del Usuario page 12

Safeguards



WARNING: Unplug cord from electrical outlet before servicing.

- **IMPORTANT:** Make sure filter bag is in place. Do not operate cleaner without filter bag. Damage to motor may occur.
- Be sure bag gasket is in place. If the white bag gasket is damaged or lost, replace at once.
- For best results, change disposable filter bag regularly even if it is not completely full. An extremely dirty bag or a bag close to full will affect the suction of the cleaner and can create excessive motor heat that could damage the motor. A good practice is to change filter bag every 30 days even if it is not full.
- Do not pick up moist material or liquids.
- Clean your vacuum cleaner with a damp (not wet) cloth in the disposable bag cavity and the outside of canister unit.
- **IMPORTANT: DO NOT REMOVE** the dirt retaining flap attached on the back of the front plate. It must be left in place for the unit to operate properly and to ensure cleaning effectiveness.
- **MOTOR PROTECTION SYSTEM:** If fine materials such as soot, cement, plaster dust, copy machine powder, etc. are picked up, the bag surface may seal and cause the motor to shut off to avoid over-heating. If this happens, turn the switch off and unplug the cleaner. Replace filter bag. Check and clear any clogs in hose or accessories. After approximately 30 min. the motor will have cooled and the cleaner will be ready to use.

Note: The cleaner must remain unplugged for 30 minutes for motor to cool and system to reset.

**IMPORTANT
SAFETY INSTRUCTIONS**

When using an electrical appliance, basic precautions should always be followed, including the following:

**READ ALL INSTRUCTIONS BEFORE
USING THIS VACUUM CLEANER**



WARNING

**To reduce the risk of fire,
electric shock, or injury:**

- Do not leave appliance unattended when plugged in. Unplug from outlet when not in use and before servicing.
- Do not use outdoors or on wet surfaces.
- Do not allow to be used as a toy. Close attention is necessary when used by or near children.
- Use only as described in this manual.
- Do not use with damaged cord or plug. If appliance is not working as it should, has been dropped, damaged, left outdoors, or dropped into water, return it to a service center or call customer service.
Commercial 1-800-242-1378
Hospitality 1-888-23-ORECK
Canada 1-866-74-ORECK
- Do not pull or carry by cord, use cord as a handle, close door on cord, or pull cord around sharp edges or corners. Do not run appliance over cord. Keep cord away from heated surfaces.
- Do not unplug by pulling on cord. To unplug, grasp the plug, not the cord.
- Do not handle plug or appliance with wet hands.
- Do not put any object into openings. Do not use with any opening blocked; keep free of dust, lint, hair and anything else that may reduce air flow.
- Keep hair, loose clothing, fingers and all parts of body away from openings and moving parts.
- Do not use to pick up anything that is burning or smoking, such as cigarettes, matches, or hot ashes.
- Do not use without filter bag assembly in place.
- Turn off all controls before unplugging.
- Use extra care when cleaning on stairs.
- Do not use to pick up flammable or combustible liquids, such as gasoline, or use in areas where they may be present.

**SAVE THESE INSTRUCTIONS
For Commercial Use**

Polarized Plug Notice

This product is equipped with a polarized alternating current line plug (a plug having one blade wider than the other). This plug will fit into the power outlet only one way. This is a safety feature. If you are unable to insert the plug fully into the outlet, try reversing the plug. If the plug should still fail to fit, contact an electrician to replace the obsolete outlet. Do not defeat the purpose of the polarized plug.

Warranty

ORECK MANUFACTURING COMPANY: (ORECK gives you the following limited warranty for this product only if it was originally purchased for use, not resale, from ORECK or an ORECK Authorized Retail Dealer.)

ORECK will repair or replace, free of charge, to the original purchaser, any part which is found to be defective in material or workmanship within one (1) year of the date of purchase.

Parts subject to normal wear are not covered by this limited warranty.

This limited warranty does not apply to any part subjected to accident, abuse, commercial use, alteration, misuse, damage caused by fire or act of God, the use of voltages other than indicated on the serial number plate of this product or service of this product by other than ORECK or an ORECK Factory Authorized Service Center.

ORECK does not authorize any person or representative to assume or grant any other warranty obligation with the sale of this product.

ORECK's limited warranty is valid only if you retain proof of purchase from ORECK or an ORECK Authorized Retail Dealer for this product. If you purchase this product from any other source, your purchase is "AS IS," which means ORECK grants you no warranty, and that you, not ORECK, assume the entire risk of the quality and performance of this product, including the entire cost of any necessary servicing or repairs of any defects.

ORECK's liability for damages to you for any costs whatsoever arising out of this statement of limited warranty shall be limited to the amount paid for this product at the time of original purchase, and ORECK shall not be liable for any direct, indirect, consequential or incidental damages arising out of the use or inability to use this product.

Some states do not allow the exclusion or limitation of incidental or consequential damages, so the above limitation or exclusion may not apply to you.

ALL EXPRESS AND IMPLIED WARRANTIES FOR THIS PRODUCT, INCLUDING IMPLIED WARRANTIES OF MERCHANTABILITY AND FITNESS FOR A PARTICULAR PURPOSE, ARE LIMITED IN DURATION TO THE WARRANTY PERIOD, AND NO WARRANTIES, WHETHER EXPRESS OR IMPLIED, WILL APPLY AFTER THIS PERIOD.

Some states do not allow limitations on the duration of implied warranties, so the above limitation may not apply to you.

This warranty gives you specific legal rights, and you may also have other rights which vary from state to state.

CALL CUSTOMER SERVICE HOT LINE
Commercial 1-800-242-1378
Hospitality 1-888-23-ORECK
Canada 1-866-74-ORECK

Whenever calling, please be sure to have your model and serial number from data plate.

Servicing of Double-Insulated Appliances

A double-insulated appliance is marked with one or more of the following: The words "DOUBLE INSULATION" or "DOUBLE INSULATED" or the double-insulation symbol (□). In a double-insulated appliance, two systems of insulation are provided instead of grounding. No grounding means is provided on a double-insulated appliance, nor should a means for grounding be added to the appliance. Servicing a double-insulated appliance requires extreme care and knowledge of the system and should be done only by qualified service personnel. Replacement parts for a double-insulated appliance must be identical to the parts they replace.

Accessory Parts List

1. Adjustable shoulder strap
2. Flexible hose
3. Crevice tool
4. Fabric tool
5. Deluxe Bare floor and wall tool
6. Tool adapter tube for fitting tools directly to vacuum when not using hose
7. Adjustable extension wand
8. Dusting brush
9. Paper filter bags
10. On Board Tool Caddy
11. Air Exhaust Deflector

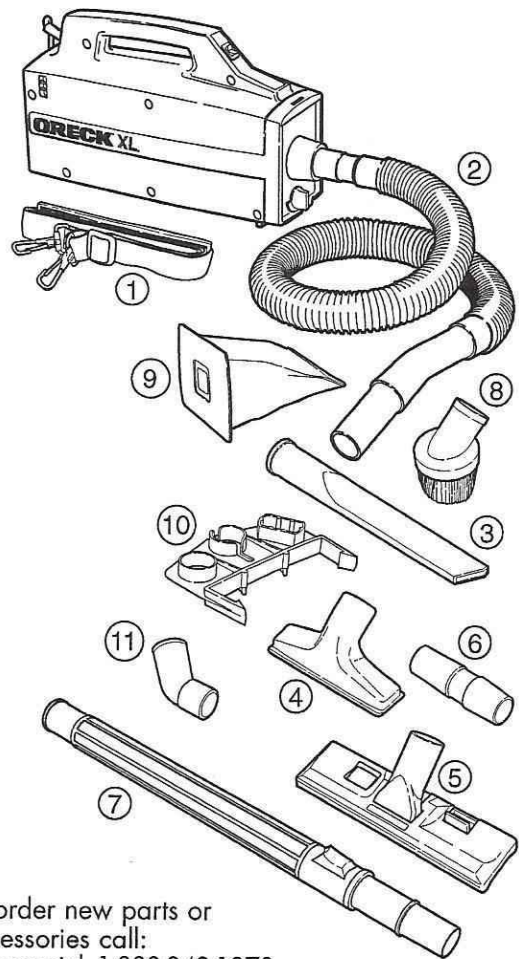

To order new parts or accessories call:
 Commercial 1-800-242-1378
 Hospitality 1-888-23-ORECK
 Canada 1-866-74-ORECK

To Operate

IMPORTANT:

DO NOT REMOVE the dirt retaining flap attached on the back of the front plate. It must be left in place for the unit to operate properly and to ensure cleaning effectiveness.



Shoulder Strap

Clamp one end of shoulder strap to ring located in front of ON/OFF switch. Clamp opposite end of shoulder strap to ring located on back of unit. Adjust length by pulling shoulder strap through clip.

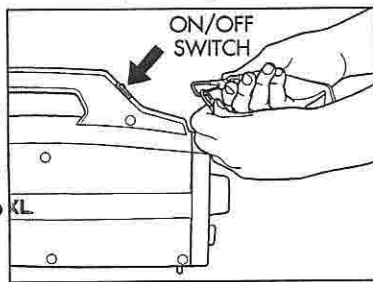

IMPORTANT: Before using shoulder strap, pull both ends to be sure it is secure.

Hose & Tool Installation

The flexible hose uses a Shurlok® locking system that prevents hose removal unless intended. To install hose, align "J" slot in hose coupling with tab inside the suction port. Insert hose in port. Twist collar clockwise to lock hose coupling in port. Twist counterclockwise and pull to remove hose.

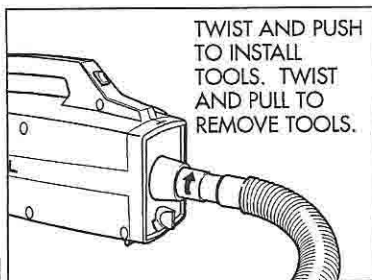

The adjustable extension wand and cleaning tools supplied with your Oreck XL Compact Cannister Vacuum lock together with friction. **Twist and push** to be sure they lock tightly when installing. Twist and pull to remove.

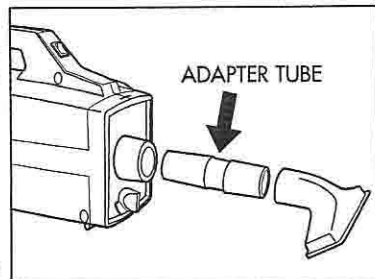

When installing tools directly to blower or suction port without using hose, tool adapter must be used.

To Operate

Blower Port

The blower port is located at the rear of the machine. Installation of tools is the same as described for suction port.

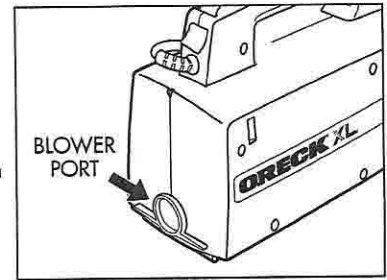

Air Exhaust Deflector

To deflect exhaust air, attach air exhaust deflector to blower port using adapter tube.

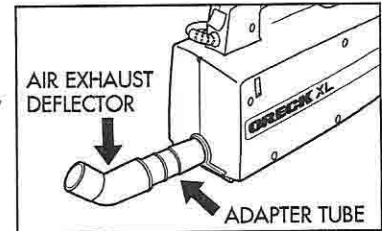

Cord Dump

Twist cord dump to easily release stored cord.

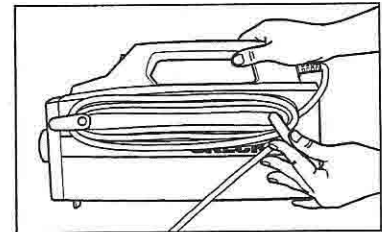

Plug cord into electrical outlet.

Power Switch

Push power switch to "ON" (I) position.

Assembly

Attach Caddy and Insert Tools

Locate caddy clip indents at top rear corners of appliance. Place appliance on firm, non-slip surface or hold in your lap. Grasp handle firmly. Place end of caddy in outside indent then strongly push and pull other end of caddy into opposite indent. Be sure rims on caddy openings face up. Avoid trapping fingers when caddy snaps on; painful pinch could result. If caddy needs to be removed, a large flat-head screwdriver inserted under caddy clip at indent can be used to carefully pry caddy loose.



Assembly

Pull cord through center opening in caddy and push until it is seated at back of slot at rear of center opening in caddy.

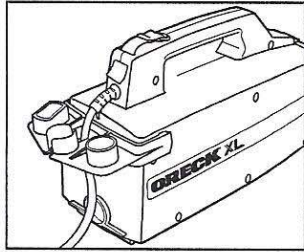

Insert crevice tool, brush and fabric tool into caddy in spaces provided.

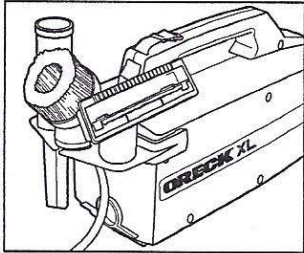

Maintenance

CHANGING THE FILTER BAG

A. Use only genuine ORECK XL filter bags. Stand unit on its back. Holding strap away from door, twist knob counterclockwise to release and lift out front plate. **B.**

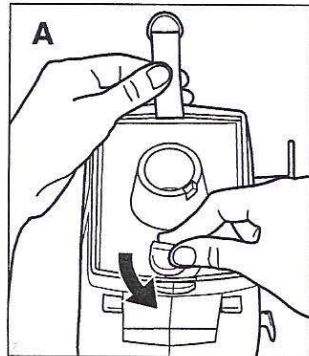
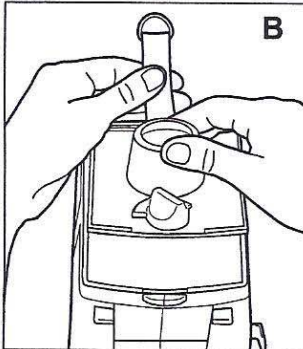

C. Remove used bag and insert fresh bag. The cardboard rim fits smoothly into the recessed top. Replace the front plate and close unit by turning knob clockwise.

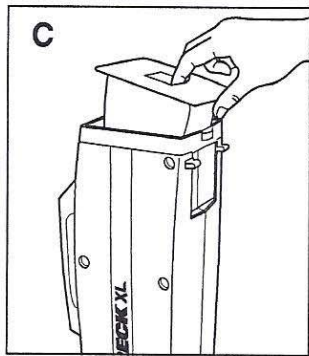

Maintenance

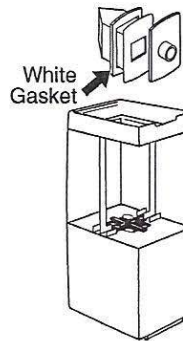

THE WHITE BAG GASKET GLUED IN THE HOUSING MUST BE IN PLACE OR UNIT WILL NOT OPERATE PROPERLY. REPLACE IF NEEDED.

REPLACING MICRO FILTER

Stand unit on its back.
Twist knob and lift out front plate.
Remove disposable bag.
Remove old filter from bottom inside unit.
Replace with new filter.

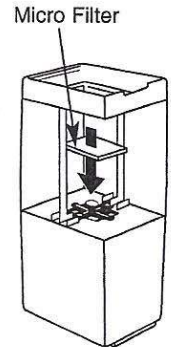

A replacement filter is supplied in each package of 12 ORECK XL filter bags or you may order filters separately.

Maintenance and Customer Service

Your ORECK COMPACT CANISTER VACUUM is a product of precise engineering. The motor bearings are permanently lubricated and should not be oiled. If you require additional information or have problems with your ORECK appliance, you may call ORECK customer service.

Commercial 1-800-242-1378
Hospitality 1-888-23-ORECK
Canada 1-866-74-ORECK

Please specify the model number and serial/code number which can be found on the data plate on the back of the vacuum.

Save your sales or purchase slip. Should your ORECK appliance require warranty service in the U.S.A., present this slip to the Authorized Service Center as your proof of purchase date, or, in Canada, call customer service.

Troubleshooting Guide

Problem	Possible Source	Areas to Check
Cleaner Will Not Run	<ol style="list-style-type: none"> 1. Not plugged in properly 2. No electricity in wall outlet. 3. Motor protector tripped. 4. Needs service. 	<ol style="list-style-type: none"> 1. Be sure cleaner is firmly plugged into wall outlet. 2. Check electrical source—fuse or circuit breaker. 3. See Motor Protection System page 2. 4. Take to service center or call for nearest service center.
Vacuum Will Not Pick Up Or Has Low Suction	<ol style="list-style-type: none"> 1. Filter bag is full. 2. Hose/wand tool is clogged. 3. Air leak due to missing or damaged gasket. 	<ol style="list-style-type: none"> 1. Replace filter bag. See "To Replace Filter Bag," page 5. 2. Remove obstructions. 3. Replace gasket. See page 5.
Tools/Wands Will Not Stay Together	<ol style="list-style-type: none"> 1. Proper friction fit not being obtained. 	<ol style="list-style-type: none"> 1. Push and turn.

ALL OTHER SERVICING SHOULD BE DONE BY AN ORECK AUTHORIZED SERVICE CENTER.

ACCESSORIES SOLD SEPARATELY

To order call: Commercial 1-800-242-1378
Hospitality 1-888-23-ORECK
Canada 1-866-74-ORECK

Replacement Treated Filter Bags (12 pk. with 1 Micro Filter) **Part No. PKBB12DW**
Replacement Micro Filter **Part No. 72005-01**
Replacement White Bag Gasket **Part No. 72017-02**
Oreck Fresh Air® Tabs **Part No. AIRTABS**
Reusable Cloth Bag **Part No. 72184-01**