

OPERATION AND PARTS MANUAL



Mikasa SERIES
MODEL MVH-150GH
(HONDA GX200K1 GASOLINE ENGINE)
MODEL MVH-150D
(ROBIN DY23-2D DIESEL ENGINE)
REVERSIBLE PLATE COMPACTOR

Revision #2 (12/04/06)

To find the latest revision of this
publication, visit our website at:
www.multiquip.com



THIS MANUAL MUST ACCOMPANY THE EQUIPMENT AT ALL TIMES.



WARNING



CALIFORNIA — Proposition 65 Warning

Engine exhaust and some of its constituents are known to the State of California to cause cancer, birth defects and other reproductive harm.

Here's How To Get Help	3
Table Of Contents	4
Parts Ordering Procedures	5
Rules For Safe Operation	6-7
Operation and Safety Decals	8
Specifications	9
General Information	10

Multiquip MVH-150GH/D Plate Compactor

Components (Plate Compactor)	11
Components (Honda GX200K1 Engine)	12
Inspection	13-14
Initial Start-Up	15-16
Operation	17
Maintenance	18-20
Preparation For Long Term Storage	21
Troubleshooting (Engine)	22-23
Troubleshooting (Plate Compactor)	24
Explanation Of Codes In Remarks Column	26
Suggested Spare Parts	27
Vibrating Plate Assembly	28-29
Body Honda GX-200 Assembly	30-31
Body Robin DY23-2D Assembly	32-33
Vibrator Assembly	34-35
Control Assembly	36-37
Name Plate And Decals	38-39

Honda GX200K1 Engine

Cylinder Head Assembly	40-41
Cylinder Barrel Assembly	42-43
Crankcase Cover Assembly	44-45
Crankshaft Assembly	46-47
Piston Assembly	48-49
Camshaft Assembly	50-51
Recoil Starter	52-53
Fan Cover Assembly	54-55
Carburetor Assembly	56-57
Air Cleaner Assembly	58-59
Muffler Assembly	60-61
Fuel Tank Assembly	62-63
Flywheel Assembly	64-65
Control Assembly	66-67

Robin DY23-2D Engine

Crankcase Assembly	68-69
Cylinder Head Assembly	70-71
Crankshaft Piston Assembly	72-73
Intake Exhaust Assembly	74-75
Muffler Air Cleaner Assembly	76-77
Governor Assembly	78-79
Cooling And Starting Assembly	80-81
Fuel And Lubricant Assembly	82-83
Fuel System Assembly	84-85
Gear Reduction Assembly	86-87

Terms and Conditions Of Sale — Parts	88
--	----

NOTE

*Specification and part number
are subject to change without
notice.*

www.multiquip.com

**Ordering parts has never been easier!
Choose from three easy options:**



Order via Internet (Dealers Only):

Order parts on-line using Multiquip's SmartEquip website!

- View Parts Diagrams
- Order Parts
- Print Specification Information



If you have an MQ Account, to obtain a Username and Password, E-mail us at: parts@multiquip.com.

To obtain an MQ Account, contact your District Sales Manager for more information.

Goto www.multiquip.com and click on **Order Parts** to log in and save!

Use the **internet** and qualify for a **5% Discount** on **Standard orders** for all orders which include complete part numbers.*

Note: Discounts Are Subject To Change



Order via Fax (Dealers Only):

All customers are welcome to order parts via Fax.

Domestic (US) Customers dial:
1-800-6-PARTS-7 (800-672-7877)

Fax your order in and qualify for a **2% Discount** on **Standard orders** for all orders which include complete part numbers.*

Note: Discounts Are Subject To Change



Order via Phone: Domestic (US) Dealers Call:
1-800-427-1244

Non-Dealer Customers:

Contact your local Multiquip Dealer for parts or call 800-427-1244 for help in locating a dealer near you.



International Customers should contact their local Multiquip Representatives for Parts Ordering information.

When ordering parts, please supply:

- | | |
|--|--|
| <ul style="list-style-type: none"> <input type="checkbox"/> Dealer Account Number <input type="checkbox"/> Dealer Name and Address <input type="checkbox"/> Shipping Address (if different than billing address) <input type="checkbox"/> Return Fax Number <input type="checkbox"/> Applicable Model Number <input type="checkbox"/> Quantity, Part Number and Description of Each Part | <ul style="list-style-type: none"> <input type="checkbox"/> Specify Preferred Method of Shipment: <ul style="list-style-type: none"> <input checked="" type="checkbox"/> UPS/Fed Ex <input checked="" type="checkbox"/> DHL ■ Priority One <input checked="" type="checkbox"/> Truck ■ Ground ■ Next Day ■ Second/Third Day |
|--|--|

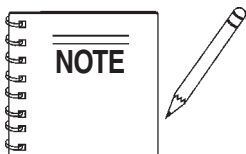

All orders are treated as *Standard Orders* and will ship the same day if received prior to 3PM PST.

WE ACCEPT ALL MAJOR CREDIT CARDS!



RULES FOR SAFE OPERATION

CAUTION:



Failure to follow instructions in this manual may lead to serious injury or even death! This equipment is to be operated by trained and qualified personnel only! This equipment is for industrial use only.

The following safety guidelines should always be used when operating the MVH-150GH/D Reversible Plate Compactor:

GENERAL SAFETY

- **DO NOT** operate or service this equipment before reading this entire manual.



- This equipment should not be operated by persons under 18 years of age.

- **NEVER** operate this equipment without proper protective clothing, steel-toed boots and other protective devices required by the job.



- **NEVER** operate this equipment when not feeling well due to fatigue, illness or taking medicine.



- **NEVER** operate this equipment under the influence of drugs or alcohol.



- **NEVER** use accessories or attachments, which are not recommended by Multiquip for this equipment. Damage to the equipment and/or injury to user may result.

- Manufacture does not assume responsibility for any accident due to equipment modifications.

- Whenever necessary, replace nameplate, operation and safety decals when they become difficult to read.

- Always check the machine for loosened threads or bolts before starting.

- **NEVER** touch the hot exhaust manifold, muffler or cylinder. Allow these parts to cool before servicing engine or compactor.



- **High Temperatures** – Allow the engine to cool before adding fuel or performing service and maintenance functions. Contact with *hot* components can cause serious burns.

- The engine section of this compactor requires an adequate free flow of cooling air. Never operate the compactor in any enclosed or narrow area where free flow of the air is restricted.

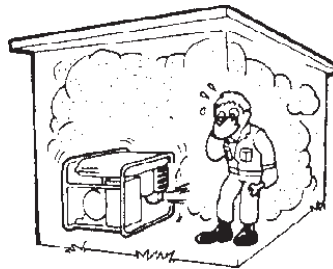

If the air flow is restricted it will cause serious damage to the compactor or engine and may cause injury to people. Remember the compactor's engine gives off **DEADLY** carbon monoxide gas.

- Always refuel in a well-ventilated area, away from sparks and open flames.



■ Always use extreme caution when working with **flammable** liquids. When refueling, **stop the engine** and allow it to cool. **DO NOT** smoke around or near the machine. Fire or explosion could result from fuel vapors, or if fuel is spilled on a hot engine.

- **NEVER** operate the compactor in an explosive atmosphere or near combustible materials. An explosion or fire could result causing severe *bodily harm or even death*.

- Topping-off to filler port is dangerous, as it tends to spill fuel.

RULES FOR SAFE OPERATION

- **NEVER** Run engine without air filter. Severe engine may occur.
- Always service air cleaner frequently to prevent carburetor malfunction.
- Always be sure the operator is familiar with proper safety precautions and operations techniques before using compactor.
- Always store equipment properly when it is not being used. Equipment should be stored in a clean, dry location out of the reach of children.
- **NEVER** use accessories or attachments, which are not
- **NEVER** use accessories or attachments, which are not recommended by Multiquip for this equipment. Damage to the equipment and/or injury to user may result.
- **NEVER** Run engine without air cleaner. Severe engine damage may occur.
- Always read, understand, and follow procedures in Operator's Manual before attempting to operate equipment.
- Always be sure the operator is familiar with proper safety precautions and operations techniques before using pump.
- Always store equipment properly when it is not being used. Equipment should be stored in a clean, dry location out of the reach of children.
- Refer to the **HONDA Engine Owner's Manual** for engine technical questions or information.

Loading and Unloading (Crane)

- Before lifting, make sure that machine parts (hook and vibration insulator) are not damaged and screws are not loosened or lost.
- Always make sure crane or lifting device has been properly secured to the hook of guard frame on compactor.
- **NEVER** lift the machine while the engine is running.
- Use adequate lifting cable (wire or rope) of sufficient strength.
- Use one point suspension hook and lift straight upwards.
- **NEVER** allow any person or animal to stand underneath the machine while lifting.
- Try not to lift machine to unnecessary heights.

Transporting

- Always shutdown engine before transporting.
- Tighten fuel tank cap securely and close fuel cock to prevent fuel from spilling.
- Drain fuel when transporting compactor over long distances or bad roads.
- Always tie-down the compactor during transportation by securing the compactor's guard frame with rope.

Emergencies

- Always know the location of the nearest **fire extinguisher** and **first aid kit**. Know the location of the nearest telephone. Also know the phone numbers of the nearest **ambulance**, **doctor** and **fire department**. This information will be invaluable in the case of an emergency.

Maintenance Safety

- **NEVER** lubricate components or attempt service on a running machine.
- Always allow the machine a proper amount of time to cool before servicing.
- Keep the machinery in proper running condition.
- Fix damage to the machine immediately and always replace broken parts.
- Dispose of hazardous waste properly. Examples of potentially hazardous waste are used motor oil, fuel and fuel filters.
- **DO NOT** use plastic containers to dispose of hazardous waste.
- **DO NOT** pour waste, oil or fuel directly onto the ground, down a drain or into any water source

MVH-150GH/D OPERATION AND SAFETY DECALS

Machine Safety Decals

The MVH-150GH/D Reversible Plate Compactor is equipped with a number of safety decals. These decals are provided for operator safety and maintenance information. The illustration below shows these decals as they appear on the machine. Should any of these decals become unreadable, replacements can be obtained from your dealer.



P/N 920207400



P/N 920203330



P/N 920201950



P/N 920207680



P/N 920207670



P/N 920207480



P/N 920207660

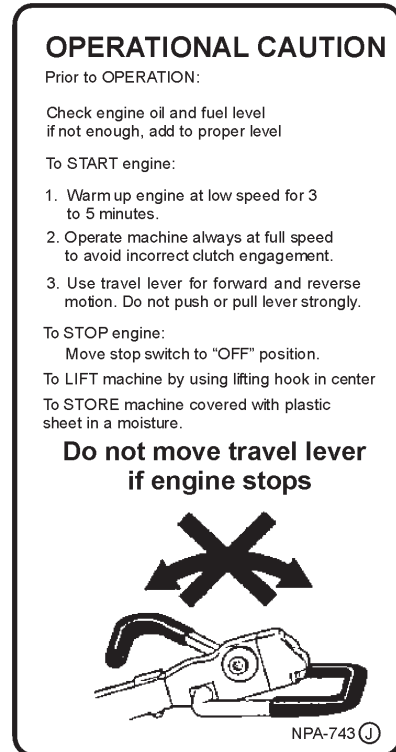

P/N 950207430



P/N 920201580



P/N (CONTACT MULTIQUIP)

MVH-150GH/D SPECIFICATIONS

TABLE 1. COMPACTOR SPECIFICATIONS

Model	MVH-150GH/D
Centrifugal Force	6,620 lbs. (3,002 kg)
Number of Vibrations	5,600 v/min (93 Hz)
Traveling Speed	(75 ft./min) 23 meters/min
Plate Size- WxL (Honda)	17" x 26" (431 x 701 mm)
Plate Size- WxL (Robin)	17" x 26" (431 x 701 mm)
Overall Width	17" (431 mm)
Overall Length	47.2" (1200 mm)
Overall Height (Honda)	35.4" (900 mm)
Overall Height (Robin)	35.4" (900 mm)
Operating Weight	331 lb. (150 kg)
Gas	35.7 (162 kg) Diesel

TABLE 2. ENGINE SPECIFICATIONS (HONDA)

Engine Make	HONDA
Engine Model	GX200
Engine Type	Gasoline
Displacement	196 cc
Maximum Output	6.5 H.P./3,600 rpm
Fuel Tank Capacity	3.8 qt./3.6 liters
Oil Capacity	1.0 qt./0.9 liters

TABLE 3. ENGINE SPECIFICATIONS (ROBIN)

Engine Make	ROBIN
Engine Model	DY23-2D
Engine Type	Diesel
Displacement	230 cc
Maximum Output	5.0 H.P./3,600 rpm
Fuel Tank Capacity	3.4 qt./3.2 liters
Oil Capacity	1.0 qt./0.9 liters

Definition of Plate Compactor

The Mikasa MVH-150GH/D is a walk behind, reversible plate compactor design for the compaction of sand, clay and asphalt. This plate compactor is a powerful compacting tool capable of applying a tremendous force in consecutive high frequency vibrations to a soil surface. Its applications include soil compacting for road, embankments and reservoirs as well as backfilling for gas pipelines, water pipelines and cable installation work.

Vibratory Plates

The vibratory plates of the MVH-150GH/D produce low amplitude high frequency vibrations, designed to compact granular soils.

The resulting vibrations cause forward motion. The engine and handle are vibration isolated from the vibrating plate. The heavier the plate, the more compaction force it generates.

Reversible Vibratory Plates

Reversible vibratory plates have two eccentric weights that allow a smooth transition for forward and reverse travel, plus increased compaction force as the result of dual weights.

Due to their weight and force, reversible plates are ideal for semi-cohesive soils.

Frequency/Speed

The compactor's vibrating plate maximum frequency is 5600 vpm (vibrations per minute). The forward and reverse travel speed of the compactor is approximately 75 ft./minute (23 meters/minute).

Engine

The Mikasa MVH-150GH/D Plate Compactor is equipped with an Honda air cooled, 4-cycle gasoline engine. The MVH-150D Plate Compactor is equipped with a Yanmar Air cooled, 4- cycle diesel engine.

Controls

Before starting the MVH-150GH/D Plate Compactor identify and understand the function of the controls and components as indicated on page 11 (Figure 1).

MVH-150GH/D COMPONENTS (PLATE COMPACTOR)

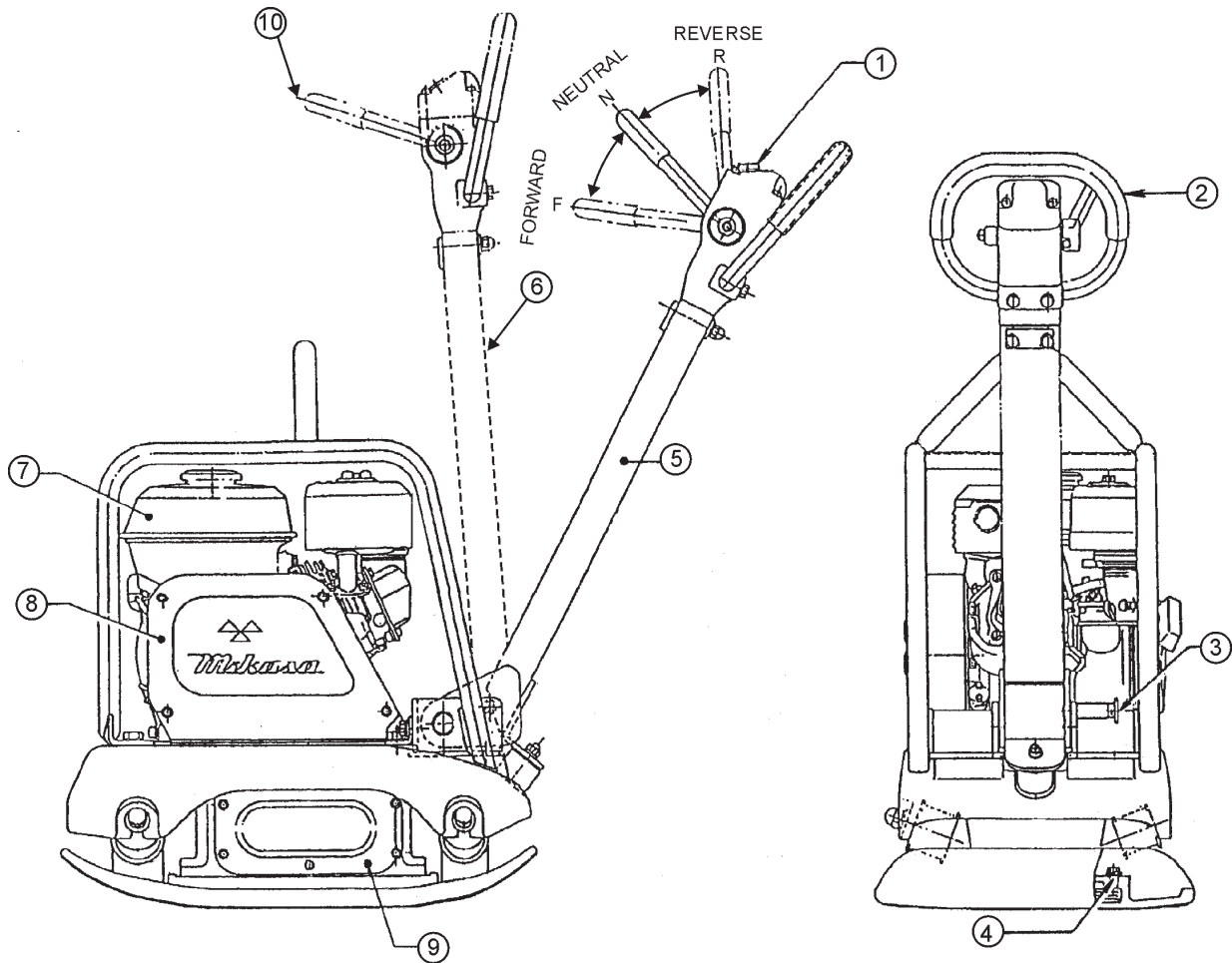

Figure 1. Compactor Controls

Figures 1 and 2 shows the location of the controls, indicators and general maintenance parts. The function of each control is described below:

1. **Breather Cap** – Remove this cap to bleed (remove air) the hydraulic system. When replacing hydraulic oil, use "Shell Tellus #46 or equivalent".
2. **Hand Grip** – When operating the compactor use this hand grip to maneuver the compactor.
3. **Handle Lock** – Pull handle bar downward (working position), then pull handle lock to lock handle bar in place.
4. **Vibration Case Oil Level Check Plug** – Remove this plug to check the vibration case oil. Oil level should be all the way up to the filler port. When replacing vibration case oil, use 10W-30 engine oil.
5. **Handle Bar (working position)** – When operating the compactor, this handle is to be in the downward position.
6. **Handle Bar (stored position)** – When the compactor is to be **stored**, move the handle bar to the upright position.
7. **Engine** – This plate compactor can use either a **HONDA GX200** gasoline engine or a **ROBIN DY23-2D** diesel engine. Refer to the respective owners manual for engine information and related topics.
8. **Belt Cover** – Remove this cover to gain access to the V-belts. **NEVER** run the compactor without the V-belt cover. If the V-belt cover is not installed, the possibility exist that your hand may get caught between the V-belt and clutch, thus causing serious injury and bodily harm.
9. **Vibration Case** – Encloses the eccentric, gears and counter weights.
10. **Forward & Reverse Lever** – **Push** the lever forward, the compactor will move in a forward direction, **pull** the lever backwards, the compactor will move in backwards direction. Placing the lever in the middle (midway) will cause the compactor not to move (neutral).

MVH-150GH/D COMPONENTS (HONDA GX200K1 ENGINE)

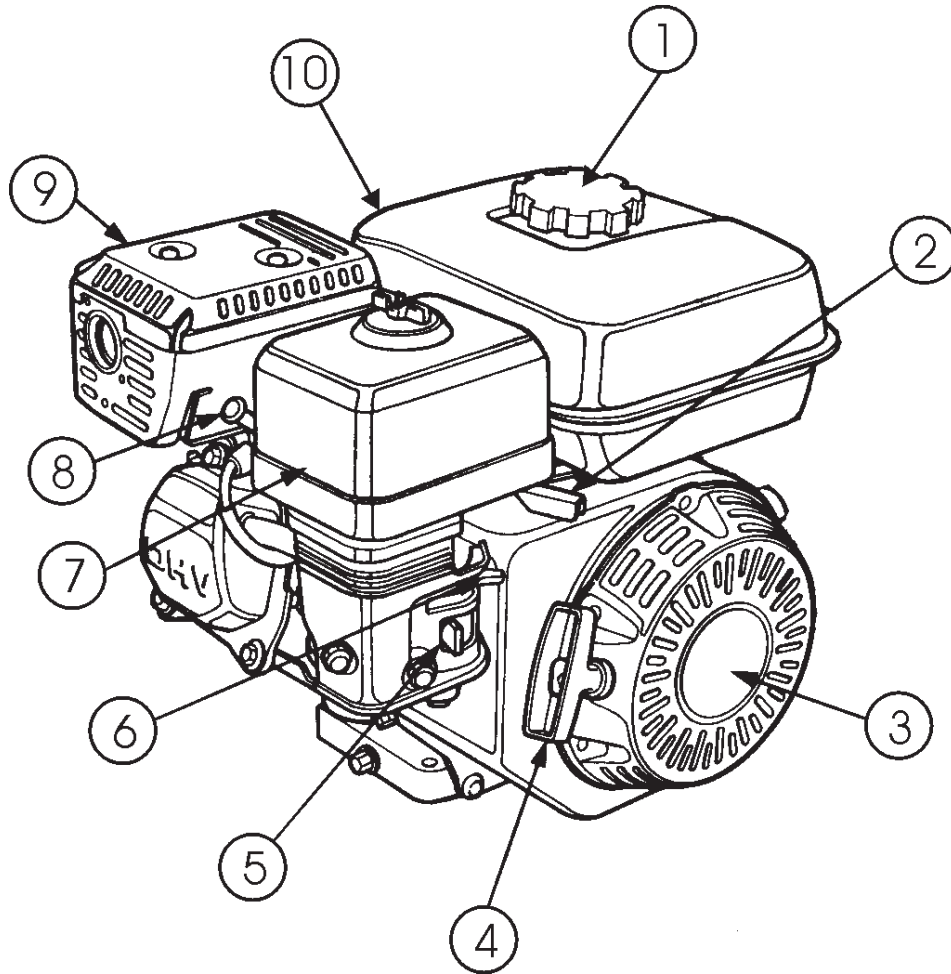

Figure 2. Engine Controls & Components

1. **Fuel Filler Cap** – Remove this cap to add unleaded gasoline to the fuel tank. Make sure cap is tighten securely. **DO NOT** over fill.
2. **Throttle Lever** – Used to adjust engine speed (fast-slow).
3. **Recoil Starter (pull rope)** – Type of engine starting method. Alternate type would be electric start (ignition key).
4. **Starter Grip** – Grip this handle to start engine. See engine starting section of this manual.
5. **Fuel Valve Lever** – **OPEN** to let fuel flow, **CLOSE** to stop the flow of fuel.
6. **Choke Lever** – Used in the starting of a cold engine, or in cold weather conditions. The choke enriches the fuel mixture.
7. **Air Cleaner** – Prevents dirt and other debris from entering the fuel system. Remove wing-nut on top of air filter cannister to gain access to filter element.
8. **Spark Plug** – Provides spark to the ignition system. Set spark plug gap to 0.6 - 0.7 mm (0.028 - 0.031 inch) Clean spark plug once a week.
9. **Muffler** – Used to reduce noise and emissions.
10. **Fuel Tank** – Gasoline engine Holds 3.8 quarts of unleaded gasoline. Diesel engine holds 3.4 quarts of diesel fuel.

Before Starting

1. Read safety instructions at the beginning of manual.
2. Clean the compactor, removing dirt and dust. Particularly, the bottom of the plate, engine cooling air inlet, carburetor and air cleaner.
3. Check the air filter for dirt and dust. If the air filter is dirty, blow through the air filter cartridge from the inside, moving a jet of dry compressed air up and down until all dust is removed. Otherwise replace air filter with a new one.
4. Check carburetor for external dirt and dust. Clean with dry compressed air.
5. Check fastening nuts and bolts for tightness. Loosened screws or bolts due to vibration, could lead to unexpected accident.

Engine Oil Check

1. To check the engine oil level, place the plate compactor on secure level ground with the engine stopped.
2. Remove the filler cap/dipstick from the engine oil filler hole (Figure 3) and wipe it clean.

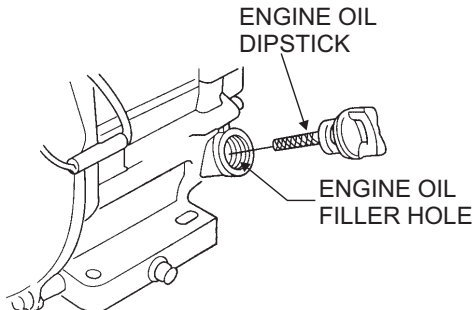

Figure 3. Engine Oil Dipstick

3. Insert and remove the dipstick without screwing it into the filler neck. Check the oil level shown on the dipstick.
4. If the oil level is low (Figure 4), fill to the edge of the oil filler hole with the recommended oil type (Table 4). Maximum oil capacity is 1 quart.

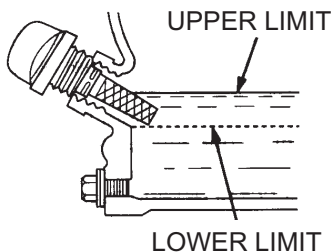

Figure 4. Engine Oil Dipstick

NOTE

The Oil Alert system will automatically stop the engine before the engine falls below safe limits. Always be sure to check the engine oil level prior to starting the engine.

Table 4. Oil Type

Season	Temperature	Oil Type
Summer	25°C or Higher	SAE 10W-30
Spring/Fall	25°C~10°C	SAE 10W-30/20
Winter	0°C or Lower	SAE 10W-10

Gasoline Check

1. Remove the gasoline cap located on top of fuel tank.
2. Visually inspect to see if fuel level is low. If fuel is low, replenish with unleaded fuel.
3. When refueling, be sure to use a strainer for filtration. **DO NOT** top-off fuel. Wipe up any spilled fuel.

Vibrator Oil Check

1. Place the MVH-150GH/D horizontally on a flat surface.
2. Check vibrator oil level by removing bolt (vibrator oil gauge) as shown in Figure 5. Use a 14 mm wrench to remove bolt. The vibrator oil level should be maintained between the two markings as shown in Figure 5. If oil is required, replace using SAE 10W-30. Maximum oil capacity is .4 qts (400 cc).

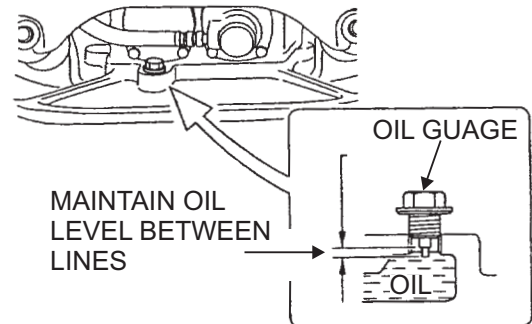

Figure 5. Vibrator Oil Gauge

Vibrator Oil Check

1. With handle bar positioned vertically (storage position), remove the breather cap (Figure 6) from the breather plug.
2. Use a 24 mm wrench and remove breather plug (Figure 6). Visually check to see if hydraulic oil comes up to the oil level line that is etched on the back side of the handle.

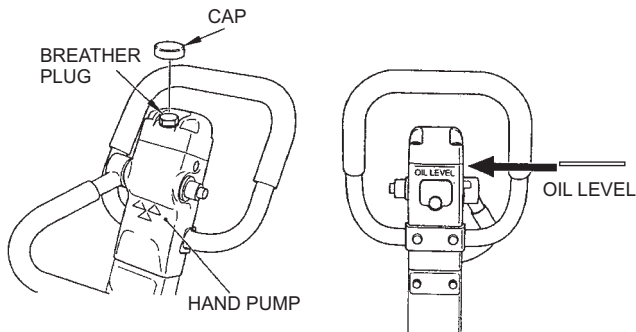

Figure 6. Vibrator Oil Gauge

2. If the hydraulic oil level is low, replace with "Shell Tellus" oil #46 or equivalent.

V-Belt Check

CAUTION:



NEVER attempt to check the V-belt with the engine running. Severe injury can occur if your hand (Figure 7) gets caught between the V-belt and the clutch. Always use safety gloves.

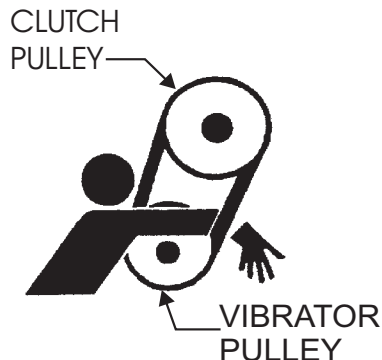

Figure 7. V-Belt Hazard

1. To check the V-belt tension (Figure 8), remove **upper** belt cover.

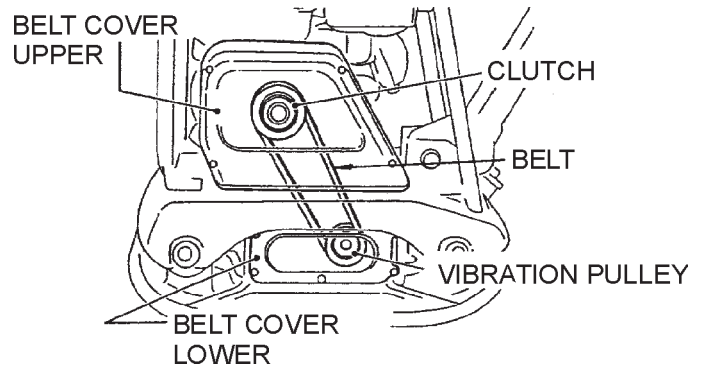

Figure 8. V-Belt Location

2. The V-belt tension is proper if the V-belt bends 10 to 15 mm (Figure 9) when depressed with finger at midway between the clutch and vibration pulley shafts.

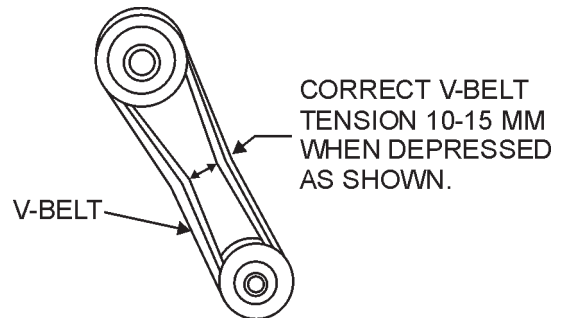

Figure 9. V-Belt Tension

3. A loose V-belt will decrease the power transmission output, causing reduced compaction and premature wear of the belt.
4. If the V-belt becomes worn or loose, replace it by using V-belt part number RPF-3350 (Honda engine) or RPF-3340 (Robin engine).

CAUTION:



DO NOT attempt to run the compactor until the Safety and Initial Start-up sections have been read,

1. Place the **fuel valve lever** (Figure 10) in the "ON" position.

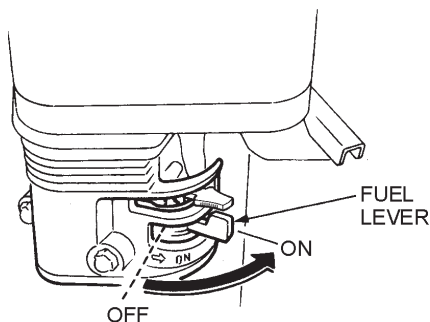

Figure 10. Fuel Valve Lever

2. Place the **Engine ON/OFF switch** (Figure 11) in the "ON" position.

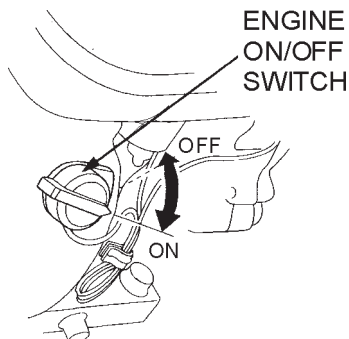

Figure 11. Engine ON/Off Switch

3. Place the **Choke Lever** (Figure 12) in the "OPEN" position.

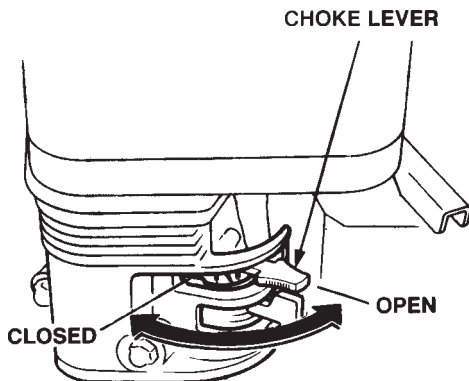

Figure 12. Choke Lever

NOTE

The **CLOSED** position of the choke lever enriches the fuel mixture for starting a **COLD** engine. The **OPEN** position provides the correct fuel mixture for normal operation after starting, and for restarting a warm engine.

4. Place the **throttle lever** (Figure 13) halfway between **fast** and **slow**.

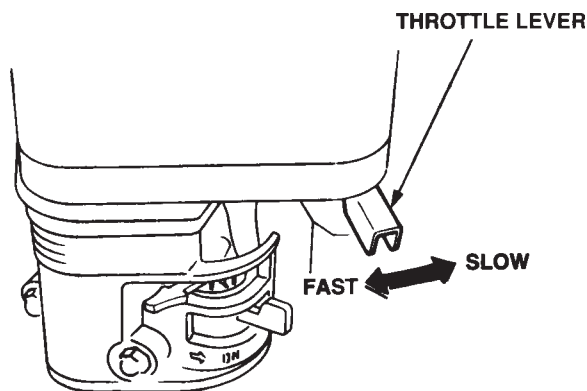

Figure 13. Throttle Lever

NOTE

Some compactor units may be equipped with a throttle lever (Figure 13A) that is located in the vicinity of the hydraulic pump. This throttle lever is connected to the engine throttle linkage.

3. Place the **Choke Lever** (Figure 12) in the "OPEN" position.

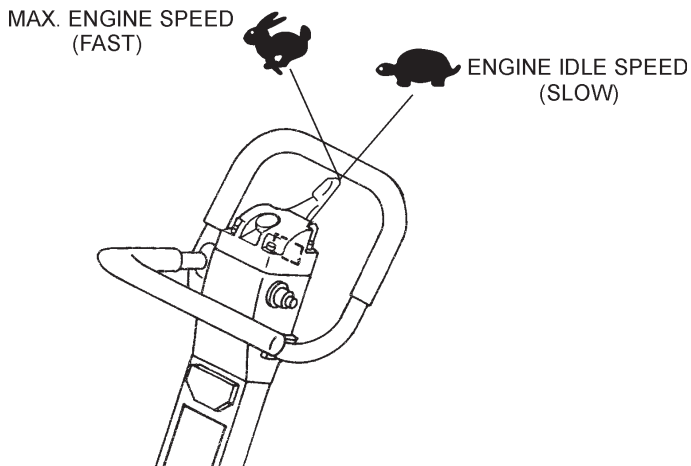

Figure 13A. Throttle Lever

5. Grasp the starter grip (Figure 14) and slowly pull it out. The resistance becomes the hardest at a certain position, corresponding the compression point. Rewind the rope a little from that point and pull out sharply.

CAUTION:



- **DO NOT** pull the starter rope all the way to the end.
- **DO NOT** release the starter rope after pulling. Allow it to rewind as soon as possible.

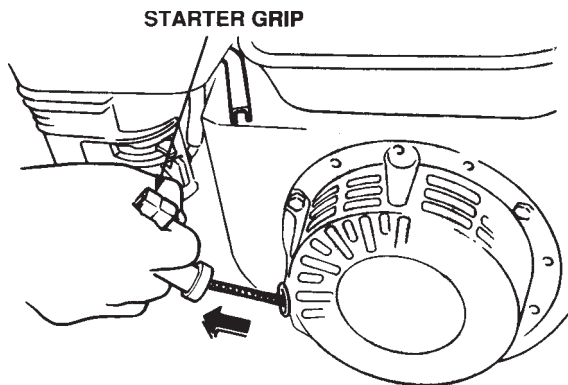

Figure 14. Starter Grip

6. If the engine has started, slowly return the choke lever (Figure 12) to the **CLOSED** position. If the engine has not started repeat steps 1 through 5.
7. Before the compactor is put into operation run the engine for 3-5 minutes.
8. Check for abnormal engine noises or fuel leaks.

CAUTION:



- **NEVER** stop the engine suddenly while working at high speeds.

1. Place the **throttle lever** (Figure 13) in **slow** position, and listen for the engine speed to decrease.
2. Place the **Engine ON/OFF switch** (Figure 11) in the "OFF" position.
3. Place the **fuel valve lever** (Figure 10) in the "OFF" position.

Operation

CAUTION:



Make sure to follow all safety rules referenced in the safety section of this manual before operating compactor. Keep work area clear of debris and other objects that could cause damage to the compactor or bodily injury.

1. Grasp the compactor's hand grip (Figure 15), and move the engine throttle lever quickly to the **fast** position.
2. With the throttle lever in the fast position, the engine speed should be around 2,300 RPM, therefore engaging the centrifugal clutch.

NOTE

Always move the throttle lever quickly without hesitation, because increasing the engine speed slowly causes the clutch to slip.

3. To make the compactor move in the forward direction push the travel lever (Figure 15) forward.

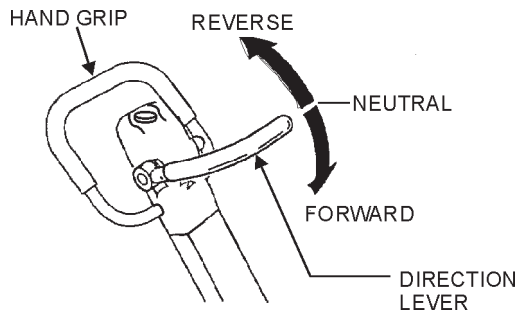
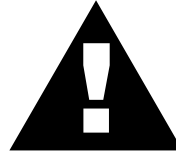

Figure 15. Direction Lever

4. To make the compactor move in the reverse direction pull the travel lever (Figure 15) backwards.
5. Firmly gasp the compactor's hand grip, the compactor will begin moving in the desired position when the direction lever has been placed in the desired position.
6. Slowly walk behind the compactor and be on the lookout for any large objects or foreign matter that might cause damage to the compactor or bodily injury.

CAUTION:



- Moving the direction lever back and forth a few times after the engine has been turned off, will cause the lever to be locked in the forward position.
 - **DO NOT** try to operate lever forcibly. The direction lever will operate normally when the engine is started and the compactor is in action.
7. Compactor traveling speed may drop on soils which contain clay, however there may be cases where traveling speed drops because the compaction plate does not leave the ground surface easily due to the composition of the soil. To rectify this problem do the following:
 - Check the bottom plate to see if clay or equivalent material has been lodge in the plate mechanism. If so, wash with water and remove.
 - Remember the compactor does not work as efficiently on clay or soils that have a high moisture content level.
 - If the soil has a high moisture level, dry soil to appropriate moisture content level or carry out compaction twice.

CAUTION:



Inspection and other services should *always* be carried out on hard and level ground with the engine shutdown.

Inspection and Maintenance Service Tables.

- To make sure your plate compactor is always in good working condition before using, carry out the maintenance inspection in accordance with Tables 5 through 7.

TABLE 5. MACHINE INSPECTION

Item	Hours of Operation	Remarks
(Starting check)	Every 8 hours (every day)	
Loosened or lost screws	Every 8 hours (every day)	
Damage of any part	Every 8 hours (every day)	
Function of controlling system part	Every 8 hours (every day)	
Leak of hydraulic system	Every 100 hours	See page 18.
Vibrator oil check	Every 300 hours	See page 19.
Vibrator oil replacement	Every 100 hours	See page 19.
Hydraulic oil check	Every 200 hours, then in every 1000 hrs.	See page 20.
V-belt (clutch) check	Every 200 hour	See page 19.

TABLE 6. ENGINE CHECK

(For details, see separate Engine Manual)	
Item	Hours of Operation
Leakage of oil or fuel	Every 8 hours (every day)
Tightness of fastening threads	Every 8 hours (every day)
Engine oil check and replenishment	Every 8 hours (every day)(Replenish to specified max. level)
Engine oil replenishment	At first 20 hours, then every 100 hours
Air cleaner cleaning	Every 50 hours

CAUTION:

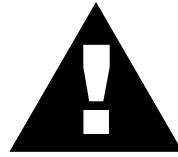

These inspection intervals are for operation under normal conditions. Adjust your inspection intervals based on the number hours plate compactor is in use, and particular working conditions.

CAUTION:

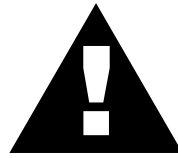

Fuel piping and connections should be replaced every 2 years.

Daily Service

- Check for leakage of fuel or oil.
- Check for loose screws including tightness. See Table 7 below (tightening torque), for retightening:

TABLE 7.

TIGHTENING TORQUE (in. kg/cm) Diameter

Material	6mm	8mm	10mm	12mm	14mm	16mm	18mm	20mm
4T	70	150	300	500	750	1,100	1,400	2,000
6-8T	100	250	500	800	1,300	2,000	2,700	3,800
11T	150	400	800	1,200	2,000	2,900	4,200	5,600
*	100 (6mm) 300 ~ 350 (8mm) 650 ~ 700 (10mm)							

* (In case counter-part is of aluminum)

(Threads in use with this machine are all right handed)

Material and quality of material is marked on each bolt, and screw.

- Remove soil and clean the bottom of compaction plate.
- Check hydraulic pump, piping and hose for any leakage. A loosened hydraulic hose can be a cause for leakage. Check hydraulic hose connections with wrench applied for tightness.
- Check engine oil, see page 13.

Engine Oil Replacement:

1. Replace engine oil, first in 20 hours of operation and every 100 hours afterwards.
2. Oil may be drained more easily when it is warm after operation (For more details, see separate HONDA Owner's Manual).

Air Filter

1. The air filter element should be cleaned because a clogged air cleaner can cause poor engine starting, lack of power and shorten engine life substantially.

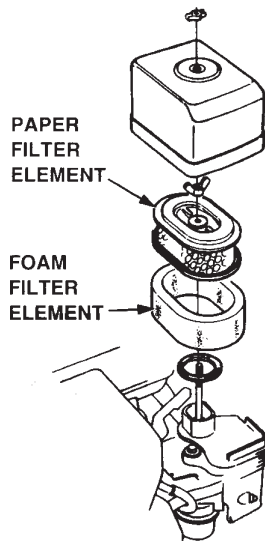

Figure 16. Air Filter

2. To clean or replace air filter loosen the wing nut on the air filter housing (Figure 16), remove the cover and take out air filter cartridge. If only cleaning of the air filter is desired blow through the air filter cartridge from the inside, moving a jet of dry compressed air up and down until all dust is removed.

CAUTION:



NEVER attempt to check the V-belt with the engine running. Severe injury can occur if your hand (Figure 7) gets caught between the V-belt and the clutch. Always use safety gloves.

Checking and Replacing the V-Belt and Clutch

1. After 200 hours of operation, remove the upper belt cover to check the V-belt tension. Tension is proper if the belt bends about 10 mm when depressed strongly with finger between shafts. Loose or worn V-belts reduces power transmission efficiency, causing weak compaction and reduces the life of the belt itself.

● Replacing the V-belt

Remove the upper and lower belt covers. Engage an offset wrench (13 mm) or the like to vibrator pulley (lower) fastening bolt. Engage waste cloth or the like at midway of V-belt on the left side and while pulling it back strongly, rotate the offset wrench clockwise so that the V-belt will come off.

● Reinstalling the V-belt

Engage V-belt to lower vibrator pulley and push the V-belt to left side of upper clutch and, in the same manner as in removal, rotate offset wrench clockwise so that the V-belt goes back on.

● Checking Clutch

Check the clutch simultaneously with V-belt checking. With belt removed, check outer drum of the clutch for seizure and "V" groove for wear or damage with your eyes. Clean the "V" groove as necessary. Wear of lining or shoe should be checked with running check. If the shoe is worn, power transmission becomes deficient and slipping will result.

CAUTION:



Whenever the compactor's vibration becomes weak or lost during normal operation regardless of operation hours, check the V-belt and clutch immediately.

Vibrator Oil Level Check

CAUTION:



Always clean the area around the vibrator oil level check hole before removing oil check plug. This will prevent dirt and debris from entering the system.

1. In every 300 hours of operation, with the machine positioned horizontally, remove vibrator oil level check plug (Figure 5) off vibrator (14 mm wrench) and see if oil is up to filler port. Be sure to clean area around check hole to prevent dirt and dust from entering.
2. In every 300 hours of operation, replace oil (capacity 400 cc). For draining oil through level check hole, have the machine inclined with a sleeper or the like placed under the compaction plate on opposite side.

* Use engine oil 10W-30 for this lubrication.

CAUTION:



Make sure hydraulic oil in hand pump is at a normal safe operating level. **DO NOT** over fill. Over filling (excessive oil) will cause excess oil to blow out of breather plug.

Hydraulic Oil

Check hydraulic oil in every 100 hours of operation. With handle bar positioned vertically (storage position), remove breather plug (Figure 1) off the top of hydraulic pump and check for proper oil level.

Replace hydraulic oil after first 200 hours and in every 1,000 hours of operation.

Replacing Hydraulic Oil

1. After removing plug cap of hand pump (Figure 6), remove plug of breather (24 mm wrench) and disconnect vibrator side of hydraulic hose (Figure 17) at vibrator cylinder. With travel lever placed in the **FORWARD** position, drain hydraulic oil in the pump.

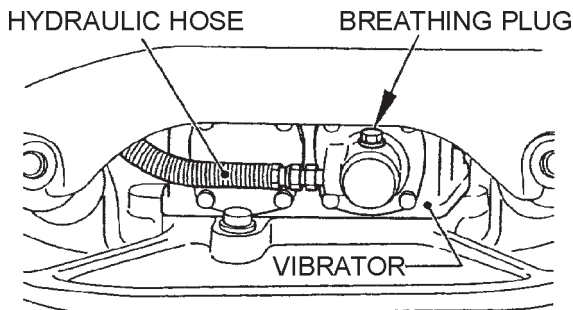

Figure 17. Hydraulic Hose

2. After draining, reconnect the hydraulic hose to vibrator.
3. Fill oil through breather hole of hand pump. (Capacity: About 300 cc). Use **Shell Tellus Oil #46** or equivalent
4. Removing breather plug at vibrator cylinder causes oil to flow out of breather hole in a while. When aeration disappears, replace the plug and tighten securely.
5. Replace breather plug of hand pump and fit the plug cap. After making sure that oil in pump is at proper level, replace the breather plug.

Troubleshooting

See Tables 7 (engine) and 8 (plate compactor) on proceeding pages for engine and plate compactor troubleshooting guide.

Pump Storage

For storage of the pump for over 30 days, the following is required:

- Drain the fuel tank completely.
- Run the engine until the fuel in the injection system is completely consumed.
- Completely drain the oil from the engine crankcase and follow procedures described in the engine Owner's Manual for engine storage.
- Completely drain the compactor's hydraulic oil from the vibrating case.
- Clean entire plate compactor, especially the bottom plate removing all dirt and foreign matter.
- Cover plate compactor and engine with plastic covering or equivalent and store in a clean, dry place.

MVH-150GH/D TROUBLESHOOTING (ENGINE)

TABLE 8. ENGINE TROUBLESHOOTING

SYMPTON	POSSIBLE CAUSE	SOLUTION
Difficult to start, "fuel is available, but no SPARK at spark plug".	Spark plug bridging?	Check gap, insulation or replace spark plug.
	Carbon deposit on spark plug?	Clean or replace spark plug.
	Short circuit due to deficient spark plug insulation?	Check spark plug insulation, replace if worn.
	Improper spark plug gap?	Set to proper gap.
Difficult to start, "fuel is available, and SPARK is present at the spark plug".	ON/OFF switch is shorted?	Check switch wiring, replace switch.
	Ignition coil defective?	Replace ignition coil.
	Improper spark gap, points dirty?	Set correct spark gap and clean points.
	Condenser insulation worn or short circuiting?	Replace condenser.
	Spark plug wire broken or short circuiting?	Replace defective spark plug wiring.
Difficult to start, "fuel is available, spark is present and compression is normal"	Wrong fuel type?	Flush fuel system, and replace with correct type of fuel.
	Water or dust in fuel system?	Flush fuel system.
	Air cleaner dirty?	Clean or replace air cleaner.
Difficult to start, "fuel is available, spark is present and compression is low"	Suction/exhaust valve stuck or protruded?	Re-seat valves.
	Piston ring and/or cylinder worn?	Replace piston rings and or piston.
	Cylinder head and/or spark plug not tightened properly?	Torque cylinder head bolts and spark plug.
	Head gasket and/or spark plug gasket damaged?	Replace head and spark plug gaskets.
No fuel present at carburetor.	Fuel not available in fuel tank?	Fill with correct type of fuel.
	Fuel cock does not open properly?	Apply lubricant to loosen fuel cock lever, replace if necessary.
	Fuel filter clogged?	Replace fuel filter.
	Fuel tank cap breather hole clogged?	Clean or replace fuel tank cap.
	Air in fuel line?	Bleed fuel line.

MVH-150GH/D TROUBLESHOOTING (ENGINE)

TABLE 8. ENGINE TROUBLESHOOTING (CONTINUED)

SYMPTON	POSSIBLE CAUSE	SOLUTION
"Weak in power" compression is proper and does not misfire.	Air cleaner not clean?	Clean or replace air cleaner
	Improper level in carburetor?	Check float adjustment, re-build carbureator.
	Defective Spark plug?	Clean or replace spark plug.
	Defective Spark plug?	
"Weak in power" compression is proper but misfires.	Water in fuel system?	Flush fuel system, and replace with correct type of fuel.
	Dirty spark plug?	Clean or replace spark plug.
	Ignition coil defective?	Replace ignition coil.
Engine overheats.	Spark plug heat value improper?	Replace with correct type of spark plug.
	Correct type of fuel?	Replace with correct type of fuel
	Cooling fins dirty?	Clean cooling fins.
Rotational speed fluctuates.	Governor adjusted correctly?	Adjust governor.
	Governor spring defective?	Replace governor spring.
	Fuel flow restricted?	Check entire fuel system for leaks or clogs.
Recoil starter malfunction.	Recoil mechanism clogged with dust and dirt?	Clean recoil assembly with soap and water.
	Spiral spring loose?	Replace spiral spring.

MVH-150GH/D TROUBLESHOOTING (PLATE COMPACTOR)

TABLE 9. PLATE COMPACTOR TROUBLESHOOTING

SYMPTON	POSSIBLE CAUSE	SOLUTION
Travel speed too low, and vibration is weak.	Engine speed too low?	Set engine speed to correct RPM.
	Clutch slips?	Check or replace clutch.
	V-belt slips?	Adjust or replace V-belt.
	Excessive oil in vibrator?	Drain excess oil and fill to proper level.
	Malfunction in vibrator housing?	Check eccentric, gears and counter weights.
Travels forward or reverse, but impossible to switch direction.	Directional components defective?	Check all directional components
	Reversing lever adjustment?	Adjust or repair reversing lever.
	Hydraulic oil hose broken?	Repair or replace hydraulic oil hose.
	Aeration in hydraulic oil for reversing system?	Bleed hydraulic oil system.
	Check valve in hand pump clogged with dust?	Clean or replace hand pump check valve.
	Piston or bearing in cylinder (vibrator assy.) is defective?	If worn, replace cylinder piston or bearing.
Does not travel either forward or reverse.	V-belt slips?	Replace V-belt.
	Clutch slips?	Check clutch springs and shoes.
	Vibrator locked?	Check vibrator housing (eccentric, gears and counterweights)
	Piston or bearing in cylinder defective?	If worn, replace cylinder piston or bearing.
Travel lever operating resistance great.	Air in hydraulic line?	Bleed hydraulic oil system.
	Piston or bearing in cylinder defective?	If worn, replace cylinder piston or bearing.

EXPLANATION OF CODE IN REMARKS COLUMN

The following section explains the different symbols and remarks used in the Parts section of this manual. Use the help numbers found on the back page of the manual if there are any questions.

The contents and part numbers listed in the parts section are subject to change **without notice**. Multiquip does not guarantee the availability of the parts listed.

Sample Parts List:

NO.	PART NO.	PART NAME	QTY.	REMARKS
1	12345	BOLT	1	INCLUDES ITEMS W/*
2*		WASHER, 1/4 IN.		NOT SOLD SEPARATELY
2*	12347	WASHER, 3/8 IN.	1	MQ-45T ONLY
3	12348	HOSE	A/R ..	MAKE LOCALLY
4	12349	BEARING	1	S/N 2345B AND ABOVE

NO. Column

Unique Symbols - All items with same unique symbol (*, #, +, %, or >) in the number column belong to the same assembly or kit, which is indicated by a note in the "Remarks" column.

Duplicate Item Numbers - Duplicate numbers indicate multiple part numbers are in effect for the same general item, such as different size saw blade guards in use or a part that has been updated on newer versions of the same machine.

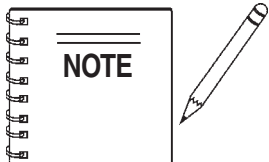

When ordering a part that has more than one item number listed, check the remarks column for help in determining the proper part to order.

PART NO. Column

Numbers Used - Part numbers can be indicated by a number, a blank entry, or TBD.

TBD (To Be Determined) is generally used to show a part that has not been assigned a formal part number at time of publication.

A blank entry generally indicates that the item is not sold separately or is not sold by Multiquip. Other entries will be clarified in the "Remarks" Column.

QTY. Column

Numbers Used - Item quantity can be indicated by a number, a blank entry, or A/R.

A/R (As Required) is generally used for hoses or other parts that are sold in bulk and cut to length.

A blank entry generally indicates that the item is not sold separately. Other entries will be clarified in the "Remarks" Column.

REMARKS Column

Some of the most common notes found in the "Remarks" Column are listed below. Other additional notes needed to describe the item can also be shown.

Assembly/Kit - All items on the parts list with the same unique symbol will be included when this item is purchased.

Indicated by:

"INCLUDES ITEMS W/(unique symbol)"

Serial Number Break - Used to list an effective serial number range where a particular part is used.

Indicated by:

"S/N XXXXX AND BELOW"

"S/N XXXX AND ABOVE"

"S/N XXXX TO S/N XXX"

Specific Model Number Use - Indicates that the part is used only with the specific model number or model number variant listed. It can also be used to show a part is NOT used on a specific model or model number variant.

Indicated by:

"XXXXX ONLY"

"NOT USED ON XXXX"

"Make/Obtain Locally" - Indicates that the part can be purchased at any hardware shop or made out of available items. Examples include battery cables, shims, and certain washers and nuts.

"Not Sold Separately" - Indicates that an item cannot be purchased as a separate item and is either part of an assembly/kit that can be purchased, or is not available for sale through Multiquip.

**MVH-150GH/D 1 TO 5 UNITS WITH HONDA
GX200, AND ROBIN DY23-2D ENGINES*****1 to 5 Units***

Qty.	P/N	Description
2	070100352	V-BELT W/ HONDA
2	070100342	V- BELT W/ ROBIN
3	956100036	THROTTLE WIRE
1	301010950	RETURN SPRING, WIRE W/ HONDA
1	959403400	RETURN SPRING, WIRE W/ ROBIN
1	956200050	THROTTLE LEVER ASSY. W/ HONDA
1	956200040	THROTTLE LEVER ASSY. W/ ROBIN
1	458337770	CLUTCH ASSY.
4	939010130	SHOCK ABSORBER
5	9807956841	SPARK PLUG W/ HONDA
1	17210ZE1822 ...	ELEMENT, AIR CLEANER, W/ HONDA
5	17218ZE1821 ...	ELEMENT, AIR CLEANER, W/ HONDA, OUTER
5	2433260008	ELEMENT, AIR CLEANER, W/ ROBIN
2	2433261108	ELEMENT, AIR CLEANER, W/ ROBIN, SPONGE
3	2436210120	FUEL FILTER ASSY. W/ ROBIN
1	2436320100	NOZZLE ASSY. W/ ROBIN
2	17620ZH7023 ...	CAP, FUEL TANK W/ HONDA
2	0430430015	CAP, FUEL TANK W/ ROBIN
3	2436430100	OIL FILTER ASSY. W/ ROBIN
1	36100ZE1015 ...	SWITCH ASSY., ENGINE STOP W/ HONDA
1	34150ZH7003 ...	OIL ALERT UNIT W/ HONDA

NOTE

Part numbers on this Suggested Spare Parts List may supercede/replace the P/N shown in the text pages of this book.

MVH-150GH/D — VIBRATING PLATE ASSY.

VIBRATING PLATE ASSY.

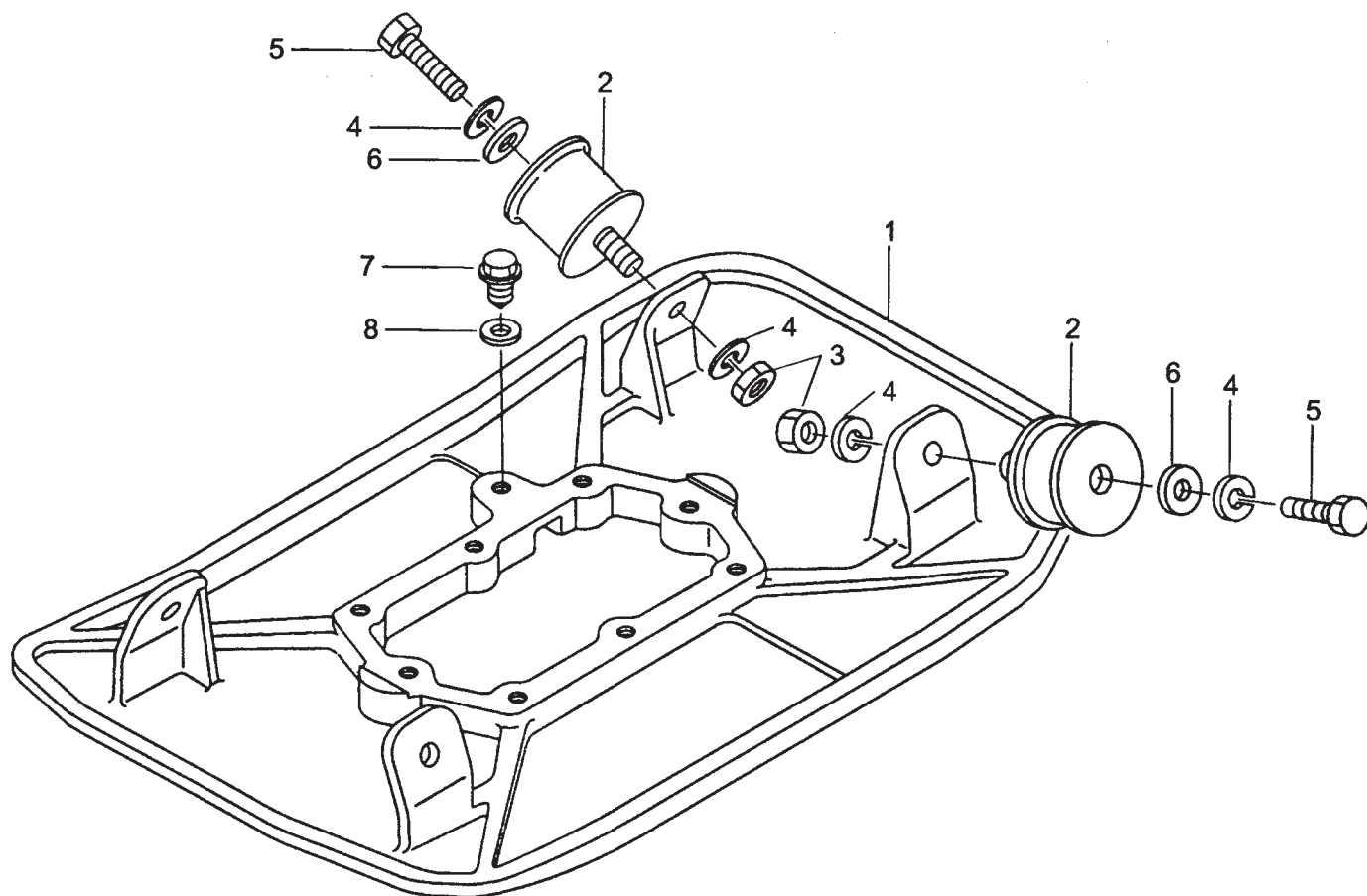

MVH-150GH/D — VIBRATING PLATE ASSY.

VIBRATING PLATE ASSY.

<u>NO</u>	<u>PART NO</u>	<u>PART NAME</u>	<u>QTY.</u>	<u>REMARKS</u>
1	459115390	VIBRATING PLATE MVH 150	1	
2	939010130	SHOCK ABSORBER MED 70S	4	
3	020312100	NUT M12	4	
4	030212300	SW M12	8	
5	001221230	BOLT T	4	
6	952405600	WASHER 12.5X35X4.5	4	
7	460449160	OIL GAUGE MVR 65W	1	
8	953405260	PACKING 1/4 CU	1	

MVH-150GH/D — BODY HONDA GX200 ASSY.

BODY ASSY.

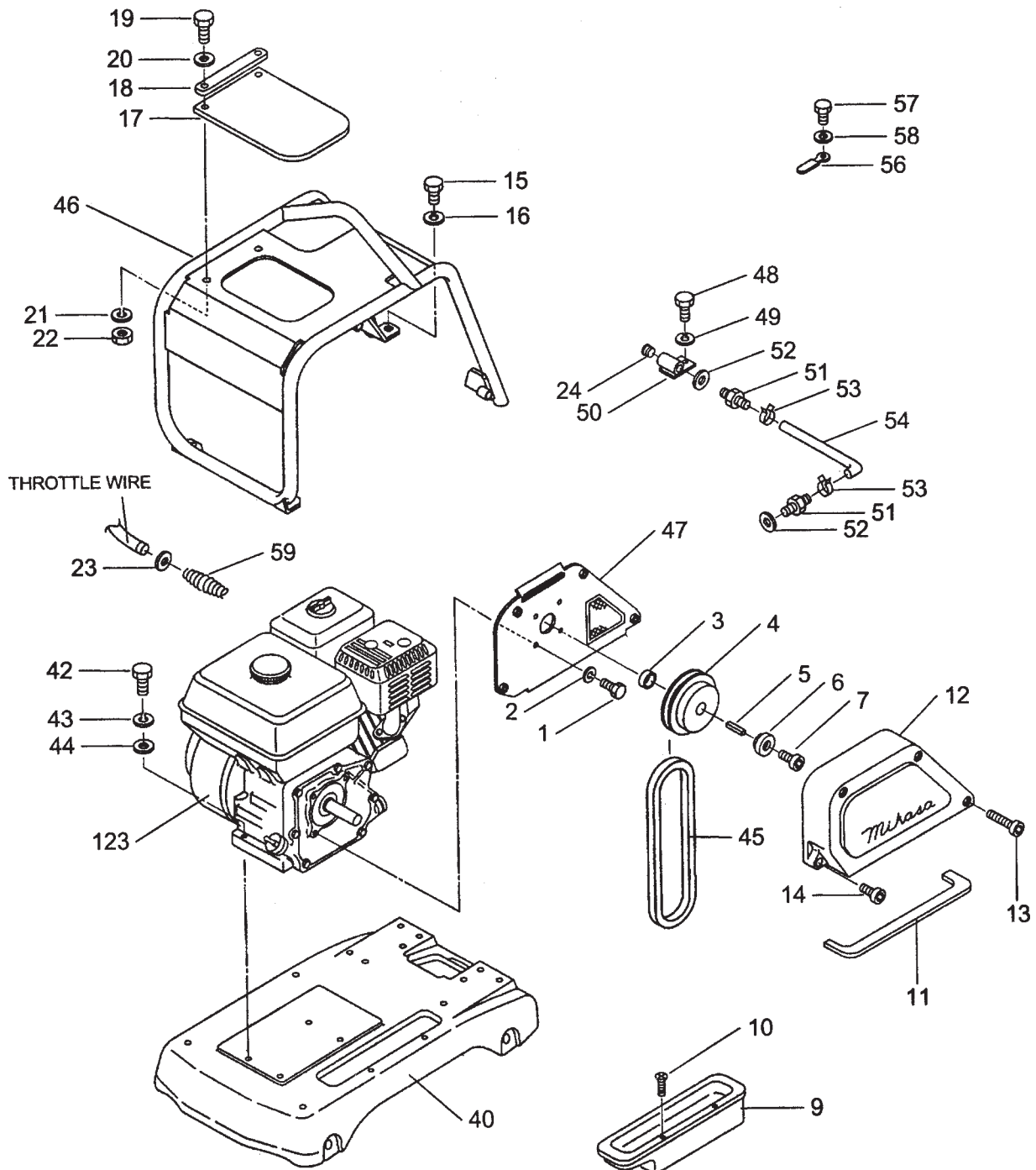

MVH-150GH/D — BODY HONDA GX200 ASSY.

BODY ASSY.

<u>NO</u>	<u>PART NO</u>	<u>PART NAME</u>	<u>QTY.</u>	<u>REMARKS</u>
1	001220820	BOLT 8X20 T	4	
2	030208200	WASHER	4	
3	458451370	SPACER 202512	1	
4	458337770	CLUTCH ASSY.	1	
5	951400100	KEY 5X5X35	1	
6	458451380	CLUTCH WASHER	1	
7	001520820	SOCKET HEAD BOLT 8X20 T	1	
9	459214530	DUST COVER	1	
10	092006010	FLAT HEAD SCREW 6X10	2	
11	459338190	SPONGE DUST COVER	1	
12	459115420	BELT COVER UPPER	1	
13	001520852	SOCKET HEAD BOLT 8X60 T	3	
14	001520820	SOCKET HEAD BOLT 8X20 T	1	
15	001221225	BOLT 12X25 T	4	
16	030212300	WASHER	4	
17	458450830	RUBBER COVER	1	
18	458450810	PLATE RUBBER COVER	1	
19	001220825	BOLT 8X25 T	2	
20	031108160	WASHER	2	
21	030208200	WASHER	2	
22	022710809	NYLON NUT M8	2	
23	031104080	WASHER	1	
24	505015380	PLUG PT1/4	1	
40	459115760	BASE GX200	1	
42	001220835	BOLT 8X35 T	4	
43	030208200	WASHER	4	
44	031108160	WASHER	4	
45	070100352	V-BELT A 35 BLUE RPF3350	1	
46	459115490	GUARD FRAME GX200	1	
47	459214550	BELT COVER PLATE GX200	1	
48	001220820	BOLT 8X20 T	1	
49	030208200	WASHER	1	
50	459452170	JOINT	1	
51	15550ZK8P90	DRAIN JOINT	2	
52	90601ZE1	WASHER DRAIN PLUG	2	
53	95002412008	HOSE CLAMP	2	
54	15552ZB9000	DRAIN HOSE	1	
56	954406290	22675101037	1	
57	001220610	BOLT 6X10 T	1	
58	030206150	WASHER	1	
59	301010950	RETURN SPRING	1	
123	912220004	ENGINE ASSY .GX200 MVH MQ	1	

MVH-150GH/D — BODY ROBIN DY23-2D ASSY.

BODY ASSY.

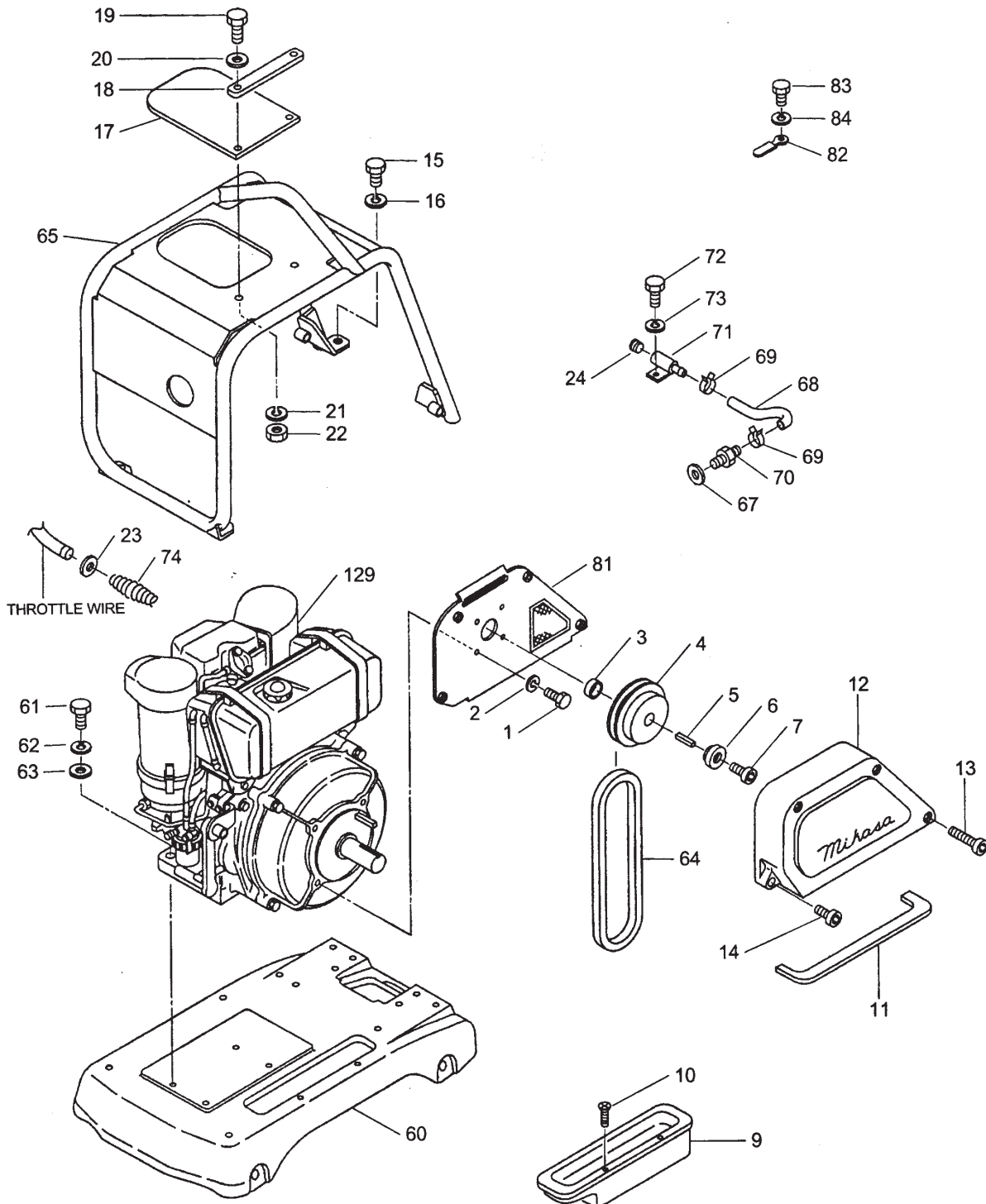

MVH-150GH/D — BODY ROBIN DY-23D ASSY.

BODY ASSY.

<u>NO</u>	<u>PART NO</u>	<u>PART NAME</u>	<u>QTY.</u>	<u>REMARKS</u>
1	001220820	BOLT 8X20 T	4	
2	030208200	WASHER	4	
3	458451370	SPACER	1	
4	458337770	CLUTCH ASSY.	1	
5	951400100	KEY 5X5X35	1	
6	458451380	CLUTCH WASHER	1	
7	001520820	SOCKET HEAD BOLT 8X20 T	1	
9	459214530	DUST COVER	1	
10	092006010	FLAT HEAD SCREW 6X10	2	
11	459338190	SPONGE DUST COVER	1	
12	459115420	BELT COVER UPPER	1	
13	001520852	SOCKET HEAD BOLT 8X60 T	3	
14	001520820	SOCKET HEAD BOLT 8X20 T	1	
15	001221225	BOLT 12X25 T	4	
16	030212300	WASHER	4	
17	458450830	RUBBER COVER	1	
18	458450810	PLATE RUBBER COVER	1	
19	001220825	BOLT 8X25 T	2	
20	031108160	WASHER	2	
21	030208200	WASHER	2	
22	022710809	NYLON NUT M8	2	
23	031104080	WASHER	1	
24	505015380	PLUG PT1/4	1	
60	459115750	BASE DY23	1	
61	001221050	BOLT 10X50 T	4	
62	030210250	WASHER	4	
63	031110160	WASHER	4	
64	070100342	V BELT A 34 BLUE RPF3340	1	
65	459115410	GUARD FRAME DY23	1	
67	0121140020	GASKET	1	
68	0211140003	DRAIN HOSE	1	
69	0091724000	HOSE CLAMP	2	
70	2286502901	UNION	1	
71	459452320	JOINT BLOCK	1	
72	001220820	BOLT 8X20 T	1	
73	030208200	WASHER	1	
74	959403400	RETURN SPRING	1	
81	4592144440	BELT COVER PLATE DY 23	1	
82	2267510103	CLAMP	1	
83	001220610	BOLT 6X10 T	1	
84	030206150	WASHER	1	
129	911402308	ENGINE ASSY. DY 23D	1	

MVH-150GH/D — VIBRATOR ASSY.

VIBRATOR ASSY.

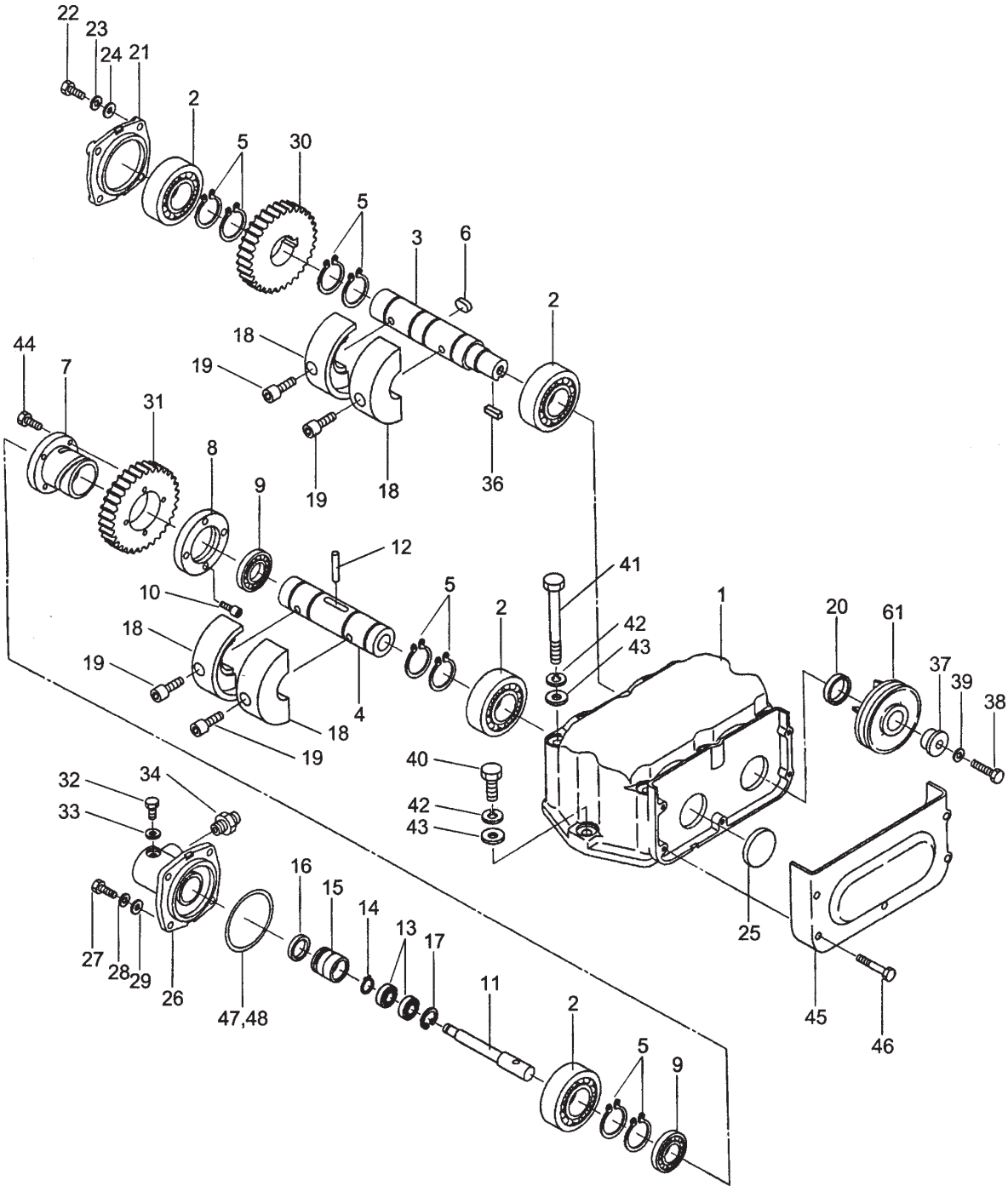

MVH-150GH/D — VIBRATOR ASSY.

VIBRATOR ASSY.

<u>NO</u>	<u>PART NO</u>	<u>PART NAME</u>	<u>QTY.</u>	<u>REMARKS</u>
1	458115150	VIBRATING CASE	1	
2	047920090	ROLLER BEARING NJ307MC4	4	
3	458337700	ROTARY SHAFT DRIVE	1	
4	458337710	ROTARY SHAFT DRIVEN	1	
5	080200350	STOP RING S-35	8	
6	951405460	KEY 10X8X19 RR	1	
7	458337720	CAM RING 210	1	
8	458337850	BEARING HOLDER	1	
9	040006807	BEARING 6807	2	
10	001520630	SOCKET HEAD BOLT 6X30 T	4	
11	458337730	PISTON ROD	1	
12	025508050	PIN 8X50	1	
13	042506000	BEARING 6000ZZSG	2	
14	080200100	STOP RING S 10	1	
15	455435051	PISTONS 22 4D	1	
16	455010070	PACKING USH 22 4X30X5	1	
17	080100260	STOP RING R 26	1	
18	459451850	ECCENTRIC ROTATOR	4	
19	009120306	SOCKET HEAD BOLT 10X30T	4	
20	060202040	OIL SEAL SC 28458	1	
21	458337740	BEARING COVER	1	
22	001220820	BOLT 8X20 T	4	
23	030208200	WASHER	4	
24	031108160	WASHER	4	
25	953405580	SEAL CUP SC 458 MVR 65W	1	
26	458214370	CYLINDER	1	
27	001220820	BOLT 8X20 T	4	
28	030208200	WASHER	4	
29	031108160	WASHER	4	
30	460333000	GEAR DRIVE	1	
31	458337840	GEAR DRIVEN	1	
32	001200812	BOLT 8X12	1	
33	953404600	COPPER PACKING 8X16X2	1	
34	954010020	CONNECTOR PT PF1/4	1	
36	951400990	KEY 7X7X20	1	
37	459452100	WASHER 9X 24 30 X 17	1	
38	001220835	BOLT 8X35	1	
39	030208200	WASHER	1	
40	001221235	BOLT 12X35 T	2	
41	001221264	BOLT 12X120 T	6	
42	030212300	WASHER	8	
43	031112230	WASHER	8	
44	001520620	SOCKET HEAD BOLT 6X20 T	4	
45	459214510	BELT COVER LOWER	1	
46	001520645	SOCKET HEAD 6X45 T	5	
47	952406170	SHIM 70 80 0 1T	1	
48	952406180	SHIM 70 80 0 2T	1	
61	459338460	PULLEY 835 W FAN	1	FOR HONDA-GX200
61	459338450	PULLEY 80D W FAN	1	FOR ROBIN- DY23

MVH-150GH/D — CONTROL ASSY.

CONTROL ASSY.

<u>NO</u>	<u>PART NO</u>	<u>PART NAME</u>	<u>QTY.</u>	<u>REMARKS</u>
1	459115450	HANDLE	1	
2	001221669	BOLT 16X145 T	1	
3	031116260	WASHER	2	
4	032116280	CONICAL SPRING WASHER M16	2	
5	020316130	NUT M16	1	
6	020416100	NUT M16	1	
8	939010010	SHOCK ABSORBER STOPPER	1	
9	020310080	NUT M10	1	
10	030210250	WASHER	1	
11	458338000	PUMP ASSY.	1	
12	459337960	TRAVEL LEVER	1	
13	001520825	SOCKET HEAD BOLT 8X25 T	2	
14	458451420	COLLAR	1	
15	033910030	WAVE WASHER 15	4	
16	458337480	PUMP HOLDER	1	
17	022710809	NYLON NUT M8	2	
18	030208200	WASHER	2	
19	459452060	OIL HOSE 940L0	1	
20	954404230	CLAMP	1	
21	001220625	BOLT 6X25 T	1	
22	020306050	NUT M6	1	
23	030206150	WASHER	1	
24	031106100	WASHER	1	
26	001220820	BOLT 8X20 T	2	
27	030208200	WASHER	2	
29	459338030	HANDLE BRACKET L	1	
30	459338040	HANDLE BRACKET R	1	
31	458450860	STOPPER	1	
32	458450880	SPRING	1	
33	458450850	GRIP	1	
34	025402516	SPRING PIN 2 5X16	1	
35	001221230	BOLT 12X30	4	
36	030212300	WASHER	4	
37	953406280	GROMMET	1	
38	458451630	BREATHER CAP	1	
39	506010070	CLAMP TC	1	
41	459338470	THROTTLE HOLDER	1	
42	371448300	CLIP M	1	
43	020305040	NUT M5	1	
44	956100036	THROTTLE WIRE	1	
45	022110504	CAP NUT M5	1	
50	956200050	THROTTLE LEVER ASSY.	1	FOR HONDA-GX200
50	956200040	THROTTLE LEVER ASSY.	1	FOR ROBIN-DY23
60	458214400	HANDLE GRIP	1	

MVH-150GH/D — NAME PLATE AND DECALS

NAME PLATE AND DECALS

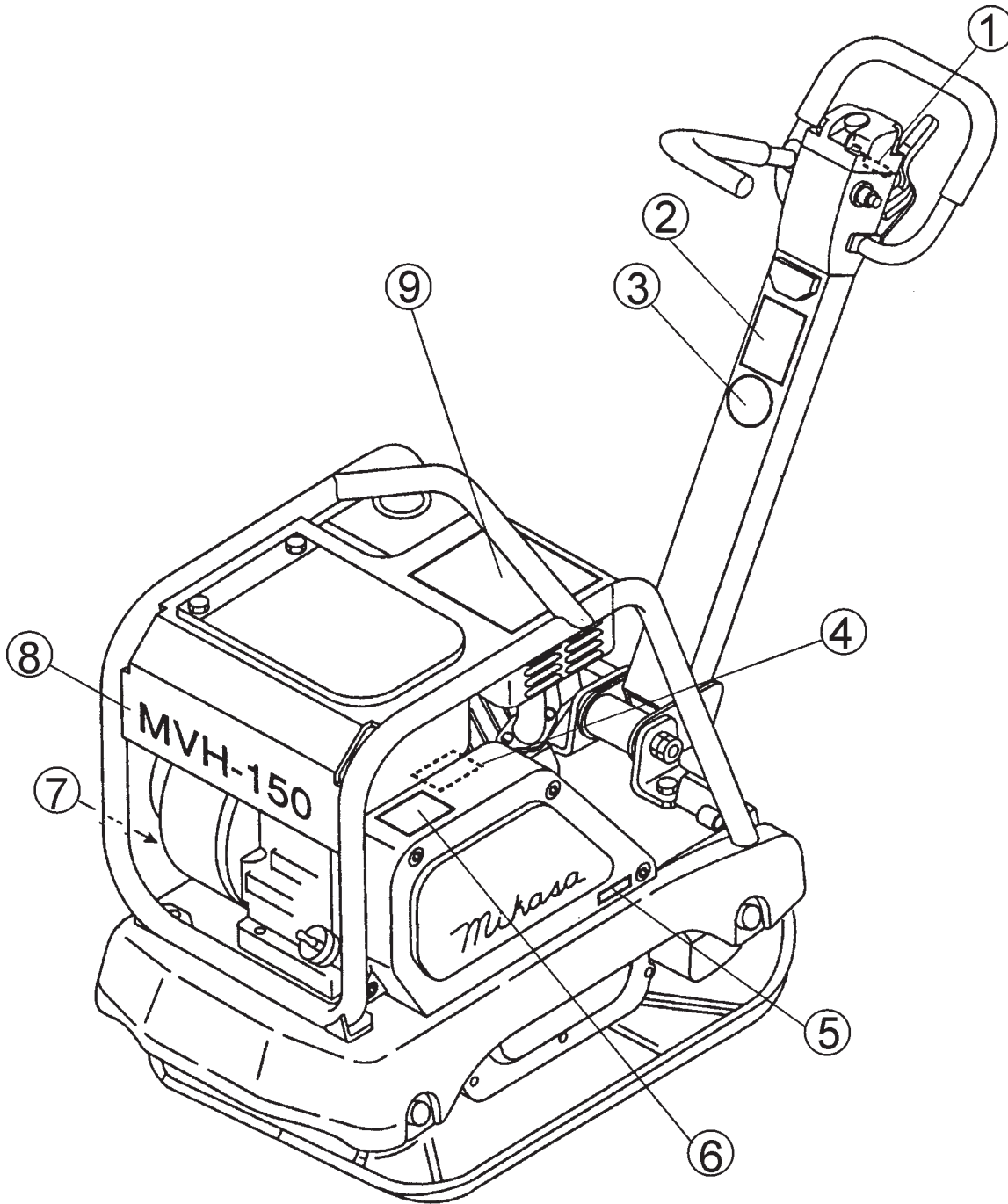

MVH-150GH/D — NAME PLATE AND DECALS

NAME PLATE AND DECALS

<u>NO</u>	<u>PART NO</u>	<u>PART NAME</u>	<u>QTY.</u>	<u>REMARKS</u>
1*	920207480	DECAL, SHELL TELLUS OIL 46	1	
2*	950207430	DECAL, CAUTION	1	
3*	920203330	EAR PROTECTION LABEL	1	
4		PLATE, SERIAL NO	1 CONTACT MQ SERVICE DEPT. W/MODEL & S/N
5*	920207670	DECAL V BELT RPF 3350	1 HONDA GX200 ONLY
5*	920207680	DECAL V BELT RPF 3340	1 ROBIN DY23-2D ONLY
6*	920201580	DECAL, MQ MARK 71X55	1	
7*	920201950	DECAL, MOTOR OIL /NPA-195	1	
8*	920207660	DECAL, MODEL/MVH-150	1	
9*	920207400	DECAL, DANGER-CAUTION	1	
	DCLMVH150GH/DY	KIT, DECAL	1 INCLUDES ITEMS W/*

SEE DECAL ILLUSTRATIONS ON PAGE 8.

HONDA GX200 ENGINE — CYLINDER HEAD ASSY.

CYLINDER HEAD ASSY.

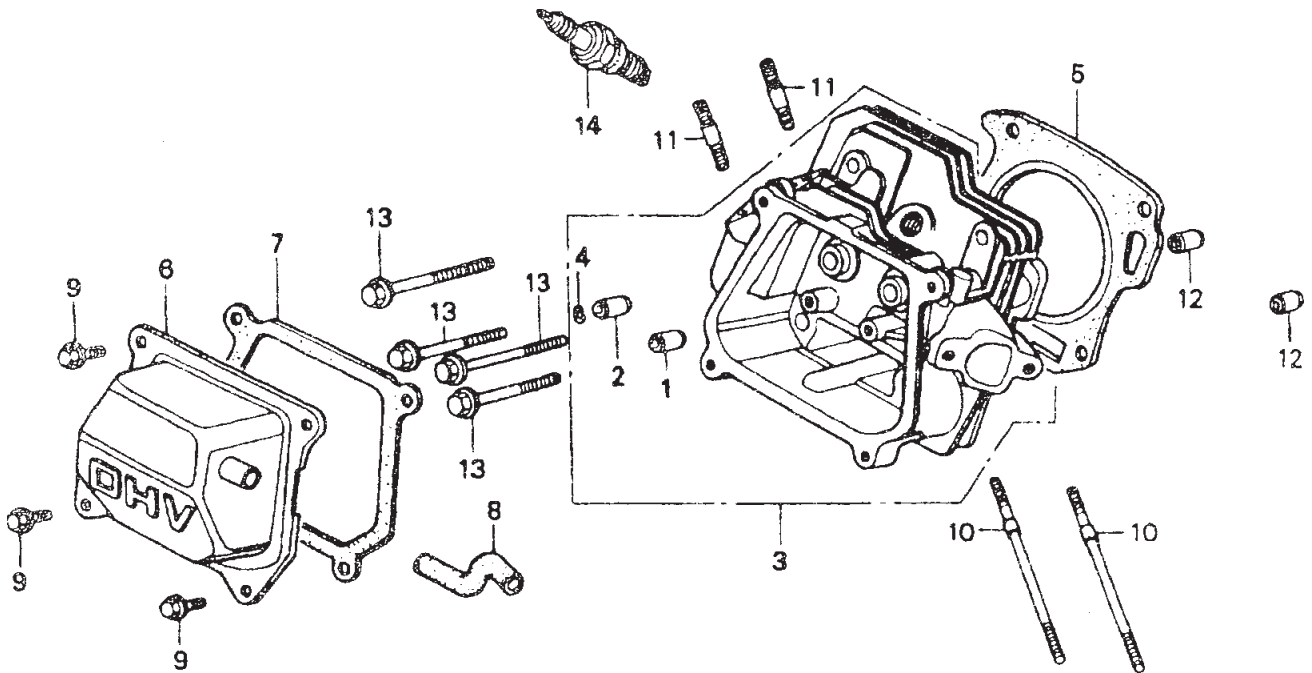

HONDA GX200 ENGINE — CYLINDER HEAD ASSY.

CYLINDER HEAD ASSY.

<u>NO</u>	<u>PART NO</u>	<u>PART NAME</u>	<u>QTY.</u>	<u>REMARKS</u>
1*	12204ZE1306	GUIDE INLET VALVE O.S.	1	
2*	12205ZE1315	GUIDE EXHAUST VALVE O.S.	1	
3	12210ZL0000	HEAD COMP CYLINDER	1	INCLUDES ITEMS W/*
4*	12216ZE5300	CLIP VALVE GUIDE	1	
5	12251ZL0003	GASKET CYLINDER HEAD	1	
6	12310ZE1010	COVER COMP HEAD	1	
7	12391ZE1000	PACKING HEAD COVER	1	
8	15721ZH8000	TUBE BREATHER	1	
9	90013883000	FLANG BOLT 6X12	4	
10	90043ZE1020	STUD BOLT 6X112	2	
11	90047ZE1000	STUD BOLT 8X32	2	
12	9430110160	KNOCK PIN 10X16	2	
13	9572308060000	FLANGE BOLT 8x60	4	
14	9807956841	SPARK PLUG BP6ES NGK	1	NGK
14	9807956854	SPARK PLUG W20EPUDENSO	1	DENSO

HONDA GX200 ENGINE — CYLINDER BARREL ASSY.

CYLINDER BARREL ASSY.

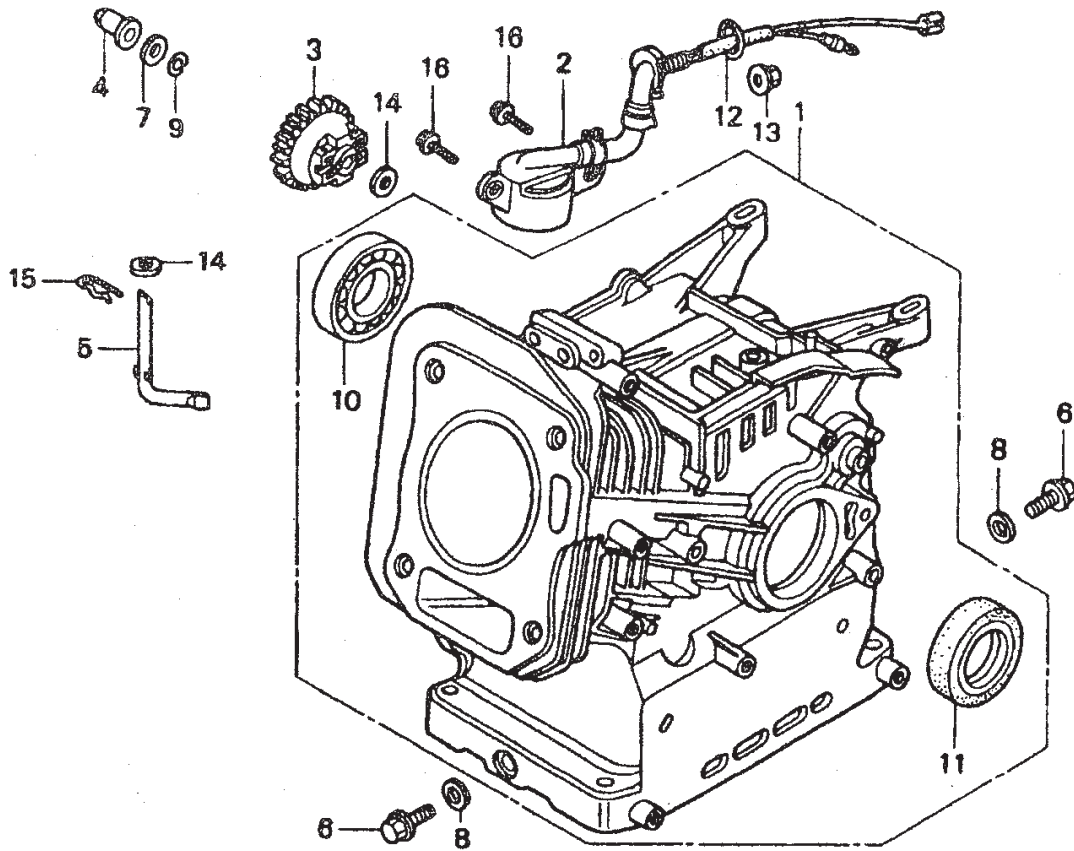

HONDA GX200 ENGINE — CYLINDER BARREL ASSY.

CYLINDER BARREL ASSY.

<u>NO</u>	<u>PART NO</u>	<u>PART NAME</u>	<u>QTY.</u>	<u>REMARKS</u>
1	12000ZL0000	BARREL ASSY. CYLINDER	1	INCLUDES ITEMS W/★
1	12000ZL0810	BARRELL ASSY. CYLINDER	1	
2	15510ZE1033	SWITCH ASSY. OIL LEVEL	1	
3	16506ZL000	GOVERNOR ASSY.	1	
4	16531ZE1000	SLIDER GOVERNOR	1	
5	16541ZE1000	SHAFT GOVERNOR ARM	1	
6	90131ZE1000	BOLT DRAIN PLUG	2	
7	90451ZE1000	THRUST WASHER 6MM	1	
8	90601ZE1000	WASHER DRAIN PLUG	2	
9	90602ZE1000	CLIP GOVERNOR HOLDER	1	
10*	91001ZF1003	BALL BEARING 6205TMB	1	
11*	91202883005	OIL SEAL 25X41X6	1	
12	91353671004	O RING 14MM	1	
13	9405010000	FLANGE NUT M 10	1	
14	9410106800	PLAIN WASHER 6MM	2	
15	9425108000	LOCK PIN 8MM	1	
16	957010601200	FLANGE BOLT 6 X 12	2	

HONDA GX200 ENGINE — CRANKCASE COVER ASSY.

CRANKCASE COVER ASSY.

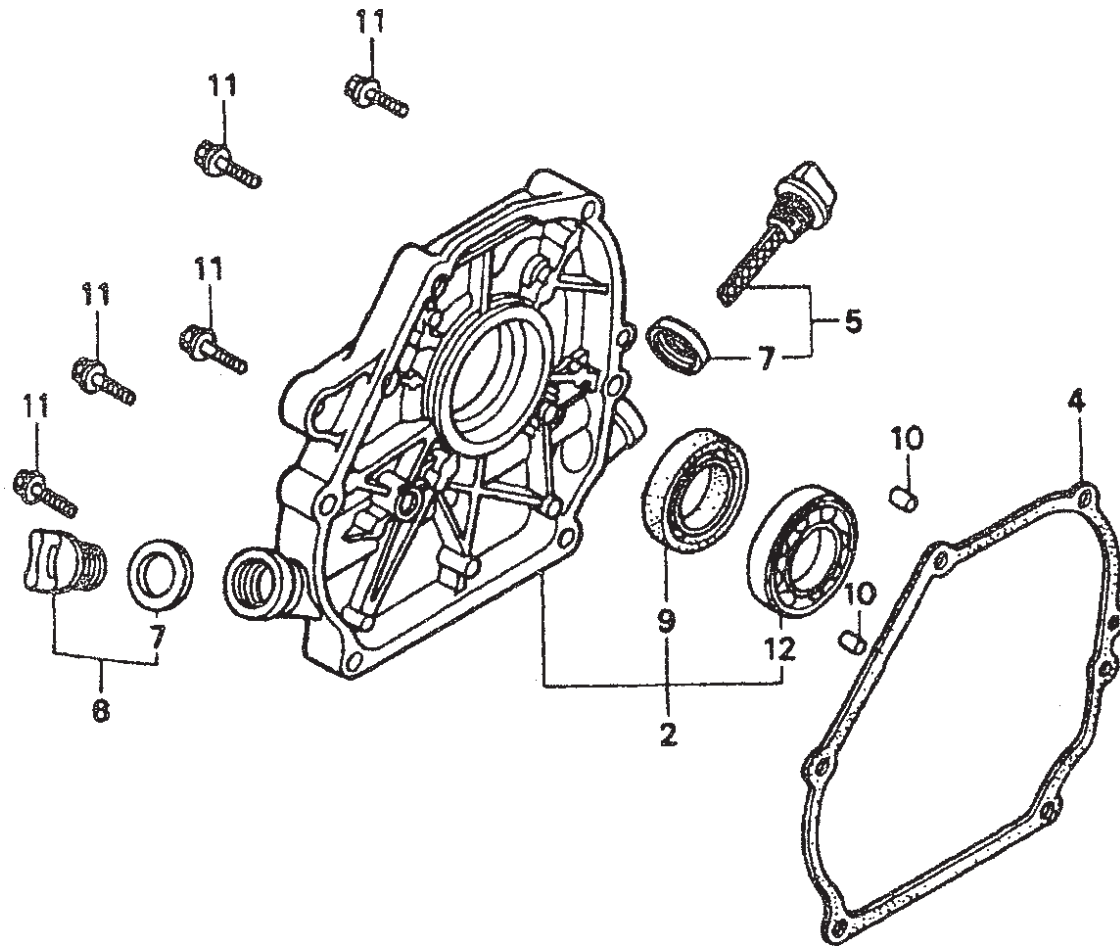

HONDA GX200 ENGINE — CRANKCASE COVER ASSY.

CRANKCASE COVER ASSY.

<u>NO</u>	<u>PART NO</u>	<u>PART NAME</u>	<u>QTY.</u>	<u>REMARKS</u>
2	11300ZE1633	COVER ASSY. CRANKCASE	1	INCLUDES ITEMS W/*
4	11381ZL0000	PACKING CASE COVER	1	
5	15600ZE1003	OIL GAUGE	1	INCLUDES ITEMS W/%
6#	15600ZG4003	OIL PLUG	1	INCLUDES ITEMS W/#
7% #	15625ZE1003	PACKING OIL FILLER CAP	2	
9*	91202883005	OIL SEAL 25X41X6	1	
10	9430108140	KNOCK PIN 8X14	2	
11	957010803200	FLANGE BOLT 8X32	6	
12*	961006205000	BALL BEARING 6205	1	

HONDA GX200 ENGINE — CRANKSHAFT ASSY.

CRANKSHAFT ASSY.

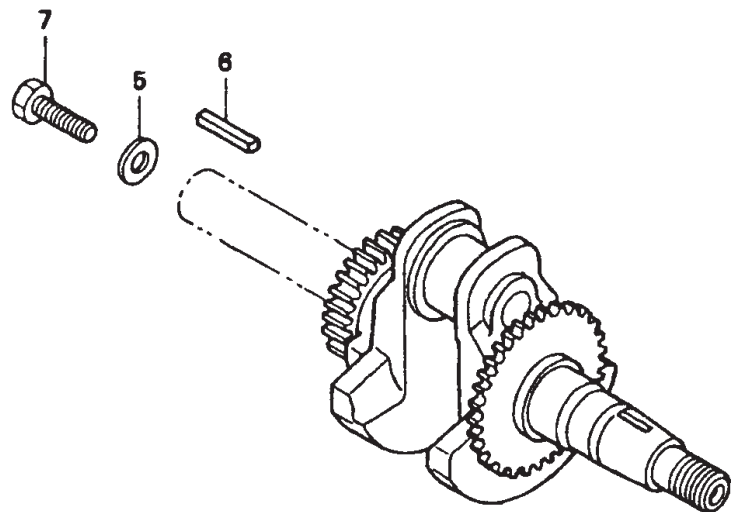
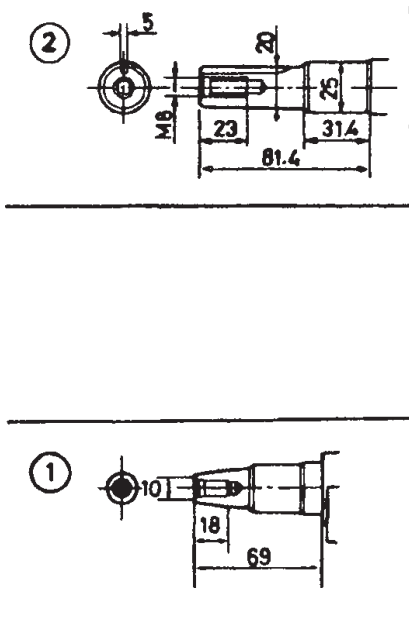

HONDA GX200 ENGINE — CRANKSHAFT ASSY.

CRANKSHAFT ASSY.

<u>NO</u>	<u>PART NO</u>	<u>PART NAME</u>	<u>QTY.</u>	<u>REMARKS</u>
1	13310ZL0A00	CRANK SHAFT COMP	1	
2	13310ZL0000	CRANK SHAFT COMP	1	
5	90473842000	WASHER 8MM	1	
6	90741883810	KEY 5X5X33	1	
7	92101080250A	BOLT 8 X 25	1	

HONDA GX200 ENGINE — PISTON ASSY.

PISTON ASSY.

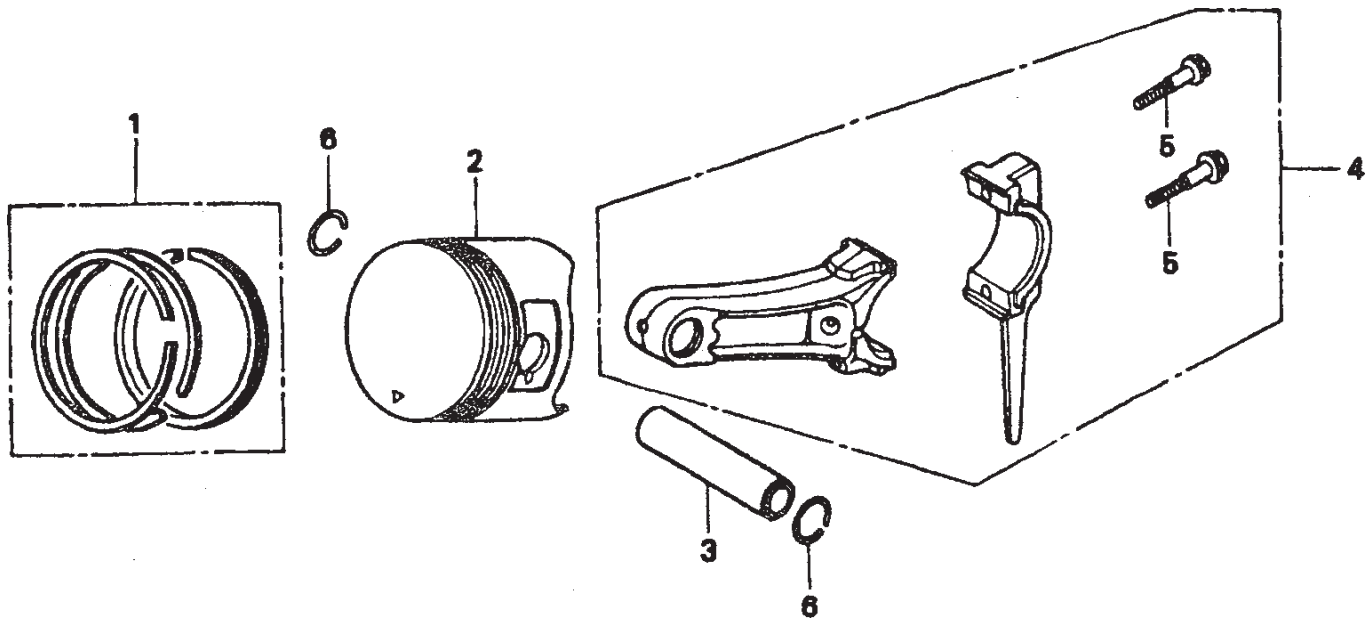

HONDA GX200 ENGINE — PISTON ASSY.

PISTON ASSY.

<u>NO</u>	<u>PART NO</u>	<u>PART NAME</u>	<u>QTY.</u>	<u>REMARKS</u>
1	13010ZL0003	RING SET PISTON STD	1	
1	13011ZL0003	RING SET PISTON 0.25	1	
1	13012ZL0003	RING SET PISTON 0.5	1	
1	13013ZL0003	RING SET PISTON 0.75	1	
2	13101XL0000	PISTON STD	1	
2	13102ZL0000	PISTON 0.25	1	
2	13103ZL0000	PISTON 0.50	1	
2	13101ZL0000	PISTON 0.75	1	
3	13111ZE1000	PISTON PIN	1	
4	13200ZE1010	CONNECTING ROD ASSY.	1	INCLUDES ITEM W/*
5*	90001ZE1000	CONNECTING ROD BOLT	2	
6	90551ZE1000	CLIP PISTON PIN 18MM	2	

HONDA GX200 ENGINE — CAMSHAFT ASSY.

CAMSHAFT ASSY.

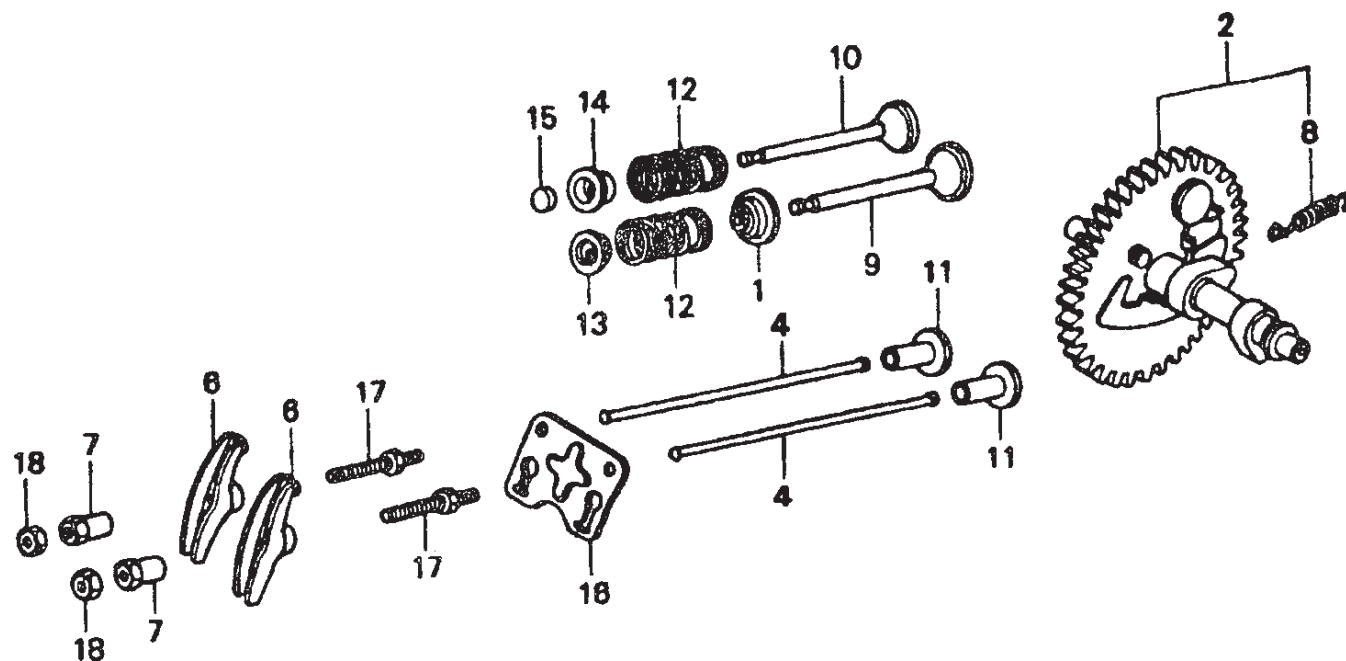

HONDA GX200 ENGINE — CAMSHAFT ASSY.

CAMSHAFT ASSY.

<u>NO</u>	<u>PART NO</u>	<u>PART NAME</u>	<u>QTY.</u>	<u>REMARKS</u>
1	12209ZL0003	SEAL VALVE STEM	1	
2	141000ZL0000	CAM SHAFT ASSY.	1	INCLUDES ITEM W/*
4	14410ZE1010	PUSH ROD	2	
6	14431ZE1000	ARM VALVE ROCKER	2	
7	14451ZE1013	PIBOT ROCKER ARM	2	
8*	14568ZE1000	SPRING WEIGHT RETURN	1	
9	14711ZF1000	INLET VALVE	1	
10	14721ZF1000	EXHAUST VALVE	1	
11	14731ZL0000	LIFTER VALVE	2	
12	14751ZF1000	SPRING VALVE	2	
13	14771ZE1000	RETAINER INTAKE VALVE	1	
14	14773ZE1000	RETAINER EXHAUSE VALVE	1	
15	14781ZE1000	ROTATOR VALVE	1	
16	14791ZE1010	PLATE PUSH ROD GUIDE	1	
17	90012ZE0010	PIBOT BOLT 8MM	2	
18	90206ZE1000	NUT PIBOT ADJUSTING	2	

HONDA GX200 ENGINE — RECOIL STARTER ASSY.

RECOIL STARTER ASSY.

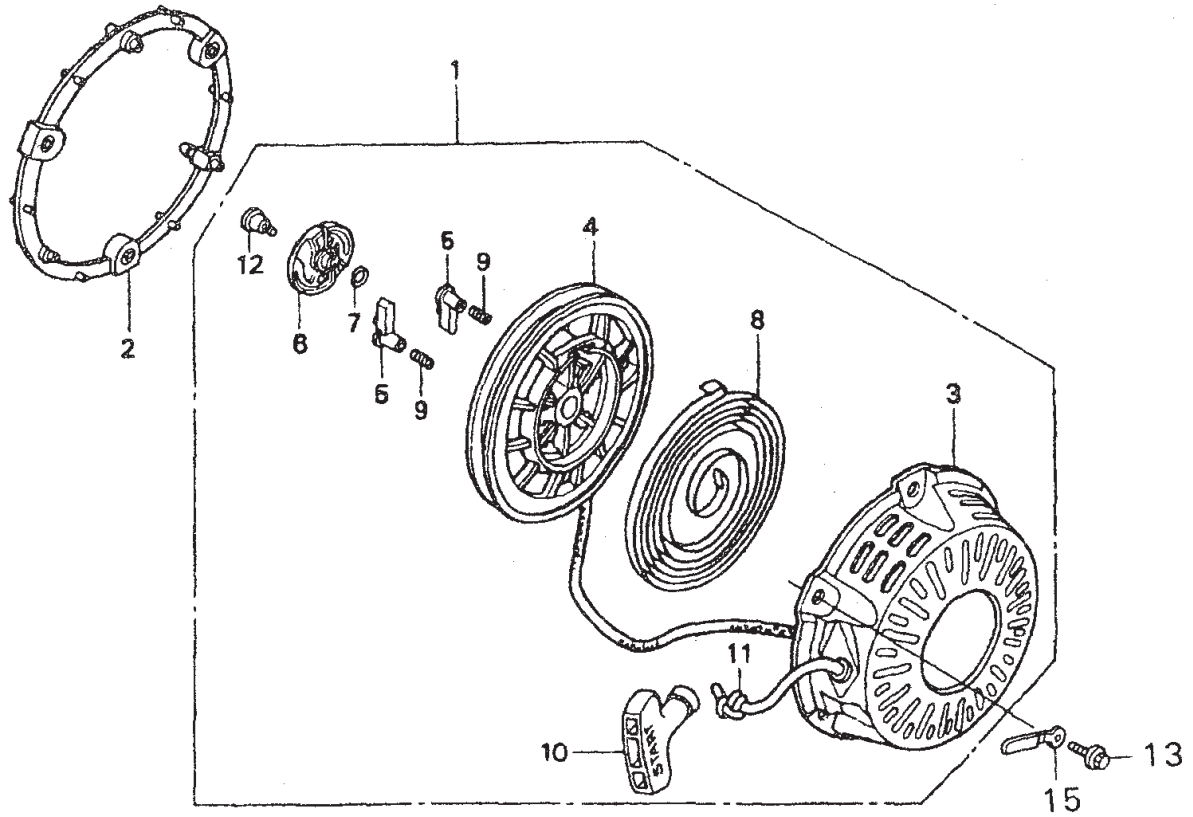

HONDA GX200 ENGINE — RECOIL STARTER ASSY.

RECOIL STARTER ASSY.

<u>NO</u>	<u>PART NO</u>	<u>PART NAME</u>	<u>QTY.</u>	<u>REMARKS</u>
1	28400ZH8013ZA	RECOIL STARTER ASSY.	1	INCLUDES ITEMS W/*
2	28405ZL0000ZB	SPACER	1	
3*	28410ZH8003ZA	CASE COMP STARTER	1	
4*	28420ZH8013	REEL RECOIL STARTER	1	
5*	28422ZH8013	RATCHET STARTER	2	
6*	28433ZH8003	RATCHET GUIDE	1	
7*	28441ZH8003	FRICTION SPRING	1	
8*	28442ZH8003	SPRING RECOIL STARTER	1	
9*	28443ZH8003	SPRING RETURN	2	
10*	28461ZH8003	STARTER KNOB	1	
11*	28462ZH8003	ROPE RECOIL STARTER	1	
12*	90003ZH8003	SET SCREW	1	
13	957010601800	FLANGE BOLT 6X18	3	
15	32901MA1000	CLIP CORD	1	

HONDA GX200 ENGINE — FAN COVER ASSY.

FAN COVER ASSY.

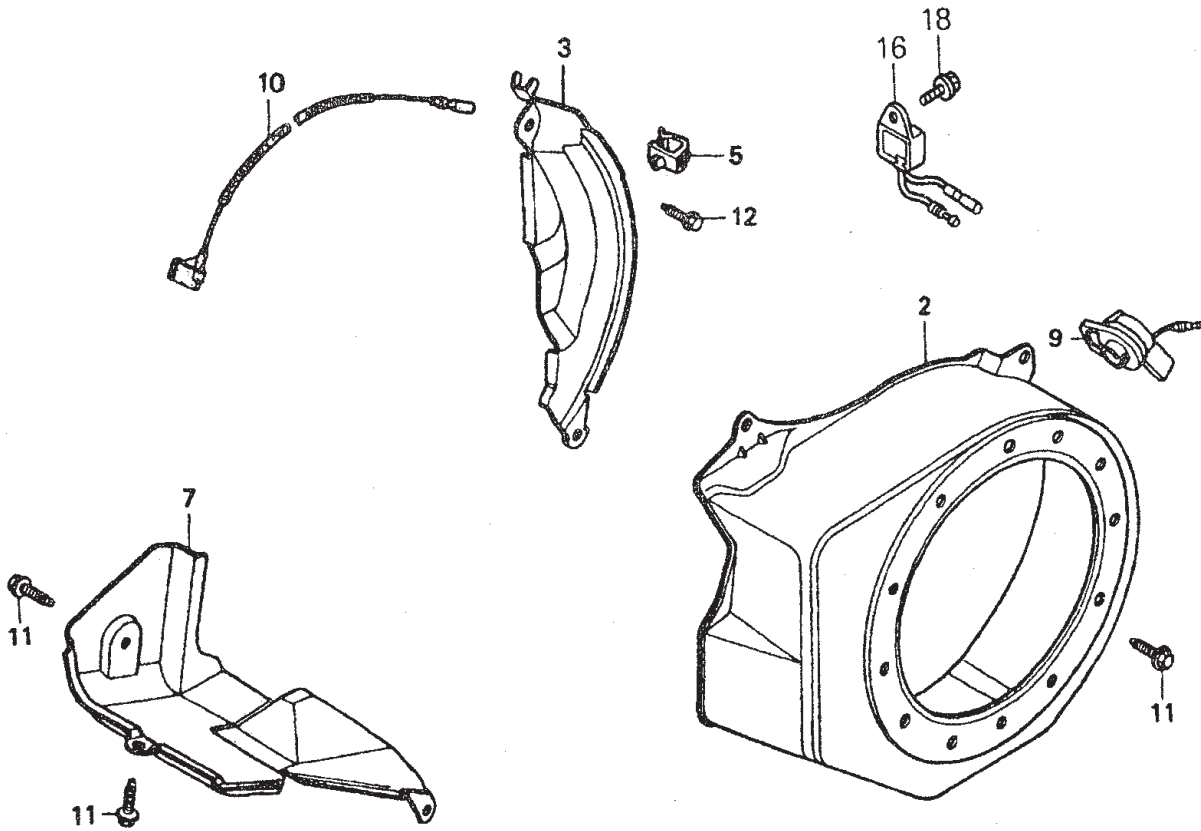

HONDA GX200 ENGINE — FAN COVER ASSY.

FAN COVER ASSY.

<u>NO</u>	<u>PART NO</u>	<u>PART NAME</u>	<u>QTY.</u>	<u>REMARKS</u>
2	19610ZL0000ZB	FAN COVER COMP	1	
3	19612ZH8000	SIDE PLATE STD	1	
3	19611ZH8810	PLATE COMP SIDE	1	
5	90601ZH7013	CLIP HARNESS	1	
7	19630ZH8000	SHROUD COMP	1	
9	36100ZE1015	SWITCH ASSY. ENGINE STOP	1	
9	36100ZH7003	STOP SWITCH ASSY.	1	
10	36101ZE1010	CORD STOP SWITCH 370MM	1	
11	90013883000	FLANGE BOLT 6X12	6	
12	90022888010	FLANGE BOLT 6X20	1	
16	34150ZH7003	ALERT UNIT OIL	1	
18	957010600800	FLANGE BOLT 6X8	1	

HONDA GX200 ENGINE — CARBURETOR ASSY.

CARBURETOR ASSY.

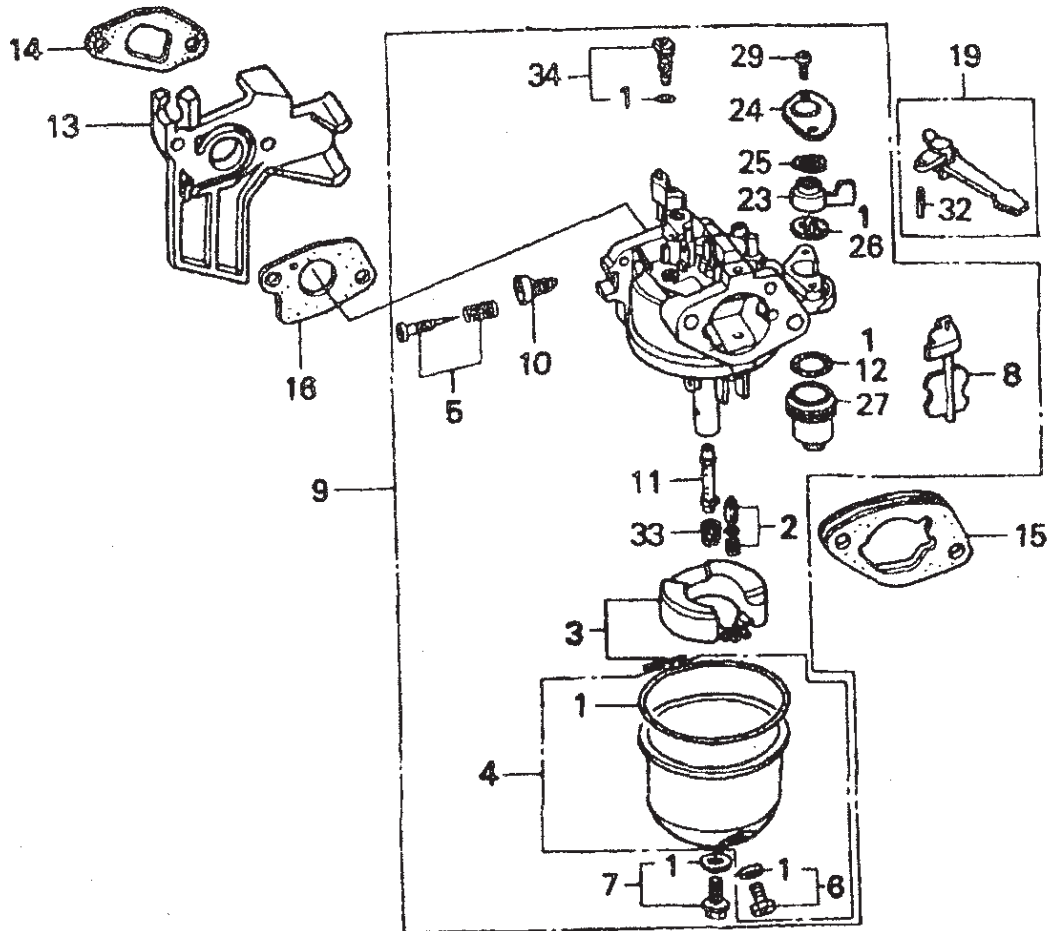

HONDA GX200 ENGINE — CARBURETOR ASSY.

CARBURETOR ASSY.

<u>NO</u>	<u>PART NO</u>	<u>PART NAME</u>	<u>QTY.</u>	<u>REMARKS</u>
1*	16010ZE1812	GASKET SET	1	
2*	16011ZE0005	FLOAT VALVE SET	1	
3*	16013ZE0005	FLOAT SET	1	
4*	16015ZE0831	FLOAT CHAMBER SET	1	
5*	16016ZE0005	PILOT SCREW	1	FG300 MCD114
5*	16016ZH7W01	SCREW SET	1	
6*	16024ZE1811	DRAIN SET	1	
7*	16028ZE0005	SCREW SET	1	
8*	16044ZE0005	CHOKE SET	1	
9*	16100ZL0005	CARBURETOR ASSY. BE64B B	1	INCLUDES ITEMS W/*
9*	16100ZL0W51	CARBURETOR ASSY BE64A A	1	INCLUDES ITEMS W/*
10*	16124ZE0005	SCREW THROTTLE STOP	1	
11*	16166ZL0000	MAIN NOZZLE	1	
12*	16173001004	PACKING CUP	1	
13	16211ZL0000	INSULATOR CARBURETOR	1	
14	16212ZH8800	PACKING INSULATOR	1	
15	16220ZE1020	SPACER COMP CARBURETOR	1	
16	16221ZH8801	PACKING CARBURETOR	1	
19	16610ZE1000	CHOKE LEVER COMP	1	INCLUDES ITEM W/#
23*	16953ZE1812	LEVER COCK	1	
24*	16954ZE1812	PLATE LEVER SETTING	1	
25*	16956ZE1811	SPRING COCK LEVER	1	
26*	16957ZE1812	PACKING FUEL COCK	1	
27*	16967ZE0811	CUP FUEL STRAINER	1	
29*	93500030061H	SCREW 3X6	2	
32#	94305020122	SPRING PIN 2X12	1	
33*	99101ZH80720	MAIN JET 72	1	
34*	99204ZA00450	PILOT JET SET #45 5- 3- 4	1	

HONDA GX200 ENGINE — AIR CLEANER ASSY.

AIR CLEANER ASSY.

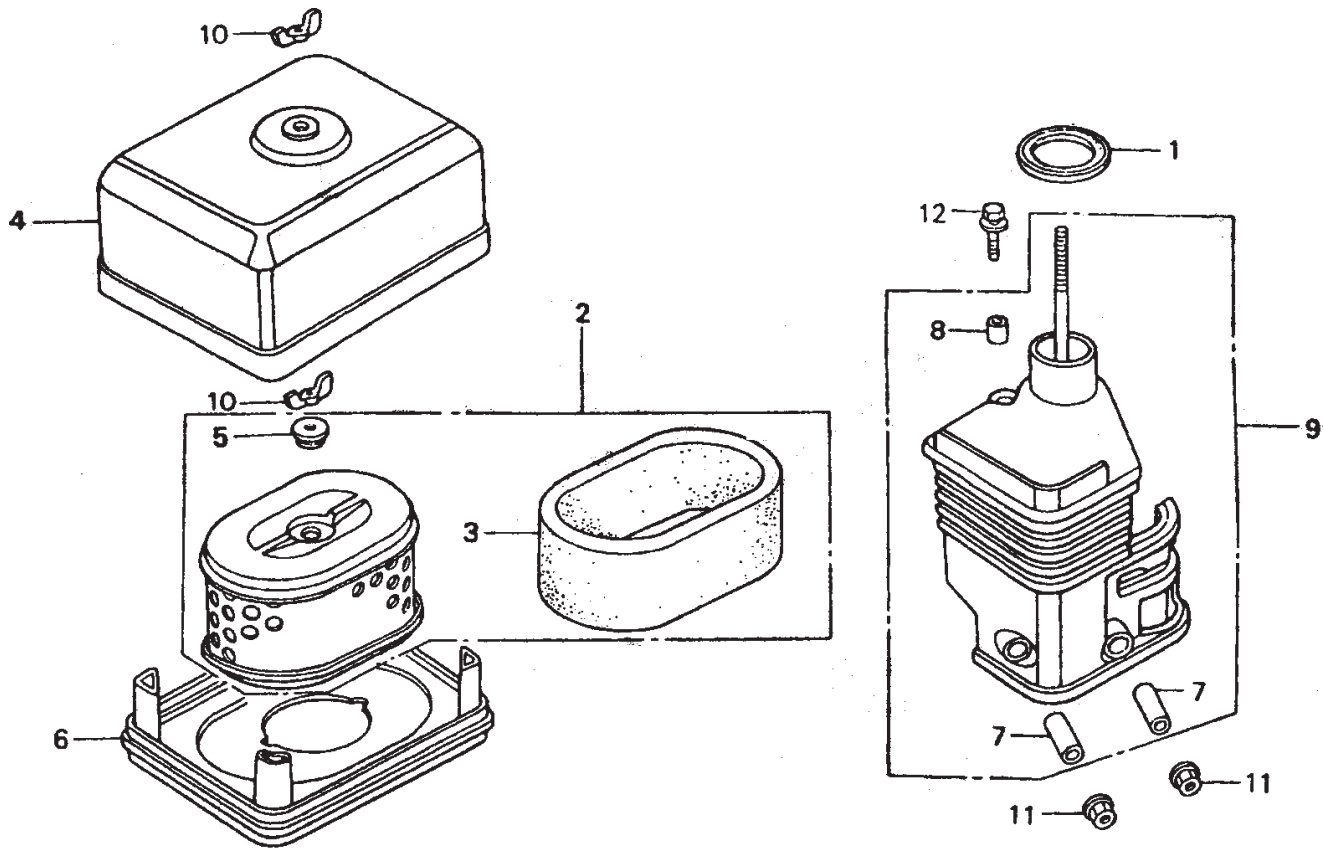

HONDA GX200 ENGINE — AIR CLEANER ASSY.

AIR CLEANER ASSY.

<u>NO</u>	<u>PART NO</u>	<u>PART NAME</u>	<u>QTY.</u>	<u>REMARKS</u>
1	16271ZE1000	PACKING ELBOW	1	
2	17210ZE1822	CLEANER ELEMENT	1	INCLUDES ITEMS W/*
3*	17218ZE1821	OUTER ELEMENT	1	
4	17230ZE1820	COVER AIR CLEANER	1	
5*	17232891000	GROMET AIR CLEANER	1	
6	17235ZE1831	NOSE SILENCER	1	
7#	17238ZE7010	COLLAR AIR CLEANER	2	
8#	17239ZE1000	COLLAR B AIR CLEANER	1	
9	17410ZE1020	ELBOW COMP AIR CLEANER	1	INCLUDES ITEMS W/#
10	90325044000	NUT	2	
11	9405006000	FLANGE NUT 6MM	2	
12	957040602000	FLANGE BOLT 6X20	1	

HONDA GX200 ENGINE — MUFFLER ASSY.

MUFFLER ASSY.

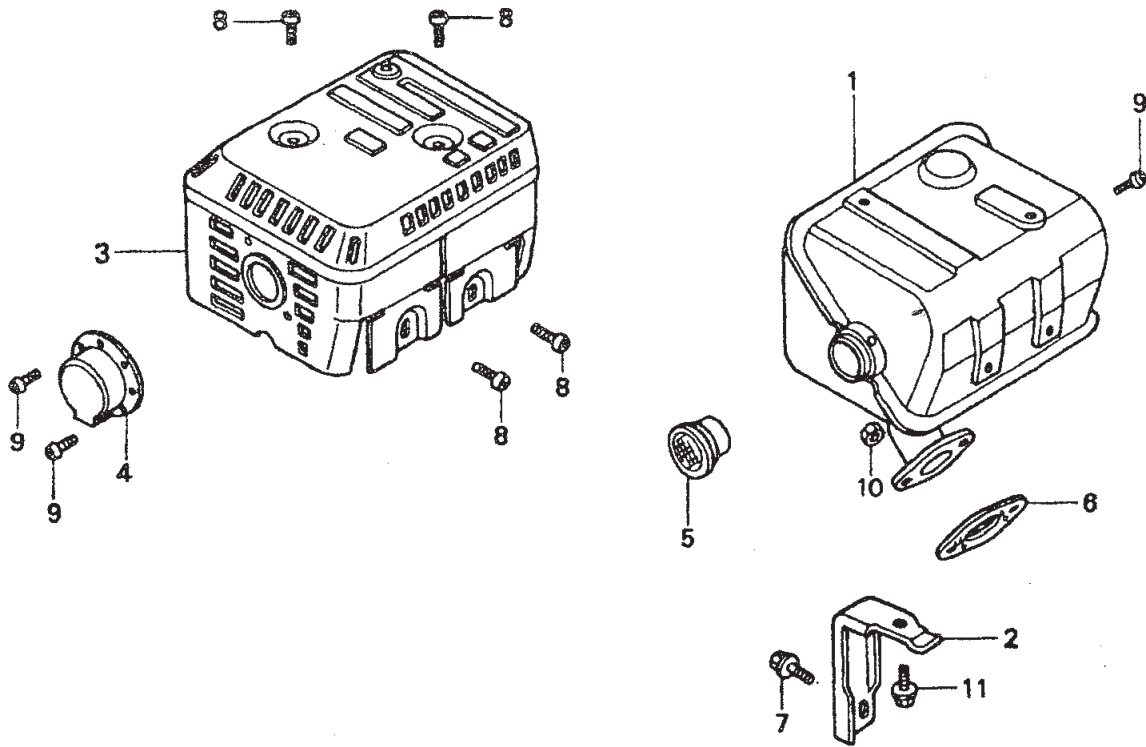

HONDA GX200 ENGINE — MUFFLER ASSY.

MUFFLER ASSY.

<u>NO</u>	<u>PART NO</u>	<u>PART NAME</u>	<u>QTY.</u>	<u>REMARKS</u>
1	18310ZL0000	MUFFLER COMP	1	
2	18315ZE1000	STAY MUFFLER	1	
3	18320ZF1H51	PROTECTOR MUFFLER	1	
4	18331883810	DEFLECTOR MUFFLER	1	
5	18361ZL0000	NETTING	1	
6	18381ZH8800	GASKET MUFFLER	1	
7	90016ZE1000	FLANGE BOLT 6X13	1	
8	90050ZE1000	TAPPING SCREW 5X8	4	
9	90055ZE1000	TAPPING SCREW 4X6	1	
9	90055ZE1000	TAPPING SCREW 4X6	3	
10	94001080000S	NUT 8MM	2	
11	957010601200	FLANGE BOLT 6X12	1	

HONDA GX200 ENGINE — FUEL TANK ASSY.

FUEL TANK ASSY.

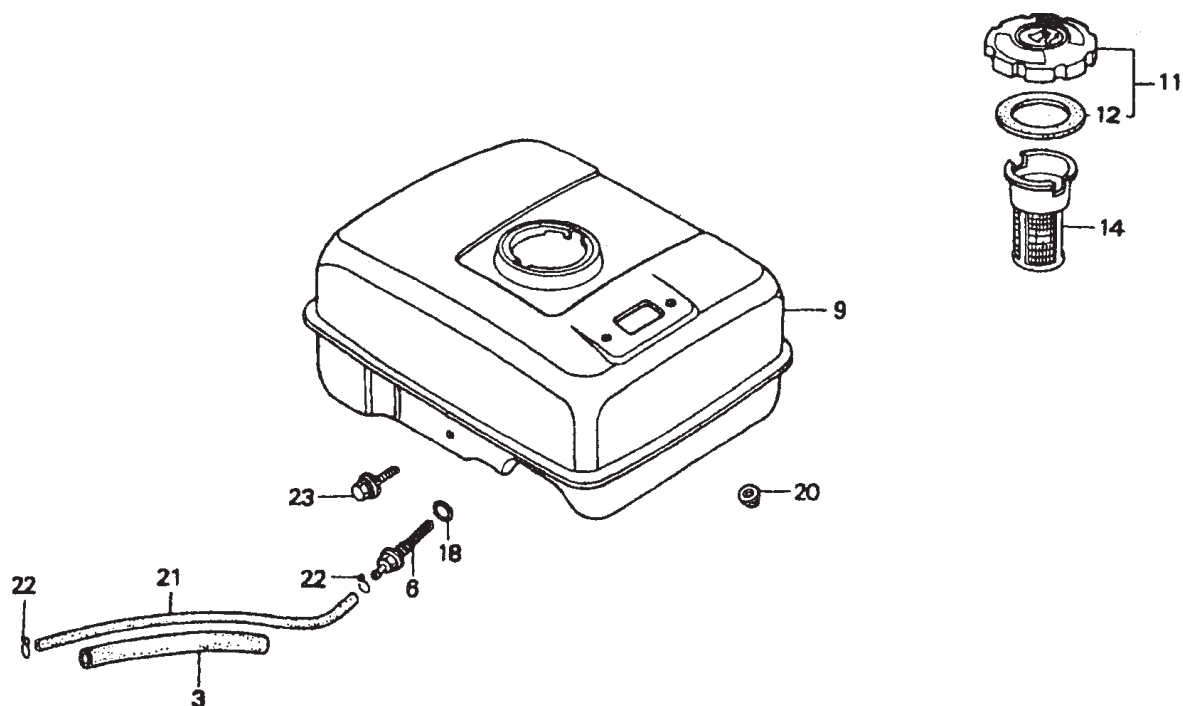

HONDA GX200 ENGINE — FUEL TANK ASSY.

FUEL TANK ASSY.

<u>NO</u>	<u>PART NO</u>	<u>PART NAME</u>	<u>QTY.</u>	<u>REMARKS</u>
3	16854ZH8000	RUBBER SUPPORT 107M	1	
6	16955ZE1000	JOINT FUEL TANK	1	
9	17510ZE1020ZA	FUEL TANK COMP	1	
11	17620ZH7023	FUEL TANK CAP CP	1	INCLUDES ITEM W/*
12*	17631ZH7003	PACKING	1	
14	17672ZE2W01	FUEL FILTER	1	
18	91353671004	O RING 14MM	1	
20	9405006000	FLANGE NUT 6MM	2	
21	950014514040	FUEL TUBE 4 5X140	1	
22	9500202080	CLIP TUBE	2	
23	957010603000	FLANGE BOLT 6X30	1	

HONDA GX200 ENGINE — FLYWHEEL ASSY.

FLYWHEEL ASSY.

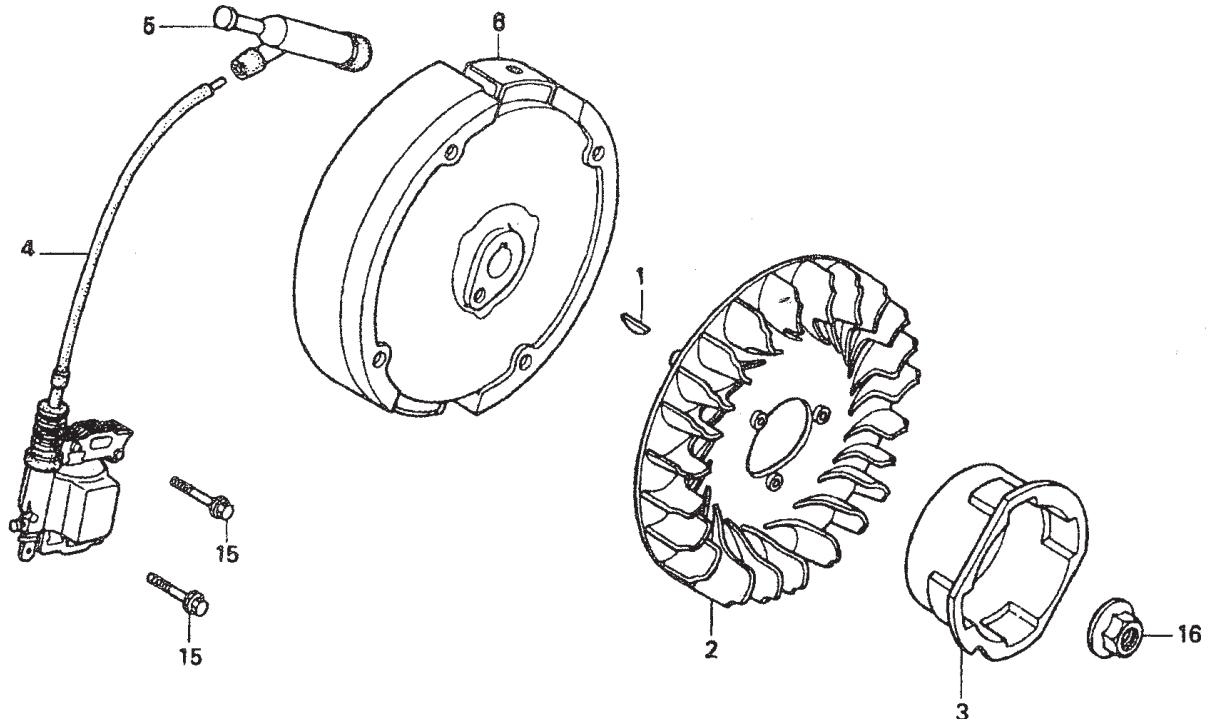

HONDA GX200 ENGINE — FLYWHEEL ASSY.

FLYWHEEL ASSY.

<u>NO</u>	<u>PART NO</u>	<u>PART NAME</u>	<u>QTY.</u>	<u>REMARKS</u>
1	13331357000	WOODRUFF KEY 25X18	1	
2	19511ZE1000	COOLING FAN	1	
3	28451ZL0000	STARTER PULLEY	1	
4	30500ZE1033	IGNITION COIL CO	1	
5	30600ZE1013	SPARK PLUG CAP	1	
6	31100ZE7010	FLYWHEEL COMP STD	1	
15	90121952000	FLANGE BOLT 6X25	2	
16	90201878003	SPECIAL NUT 14MM	1	

HONDA GX200 ENGINE — CONTROL ASSY.

CONTROL ASSY.

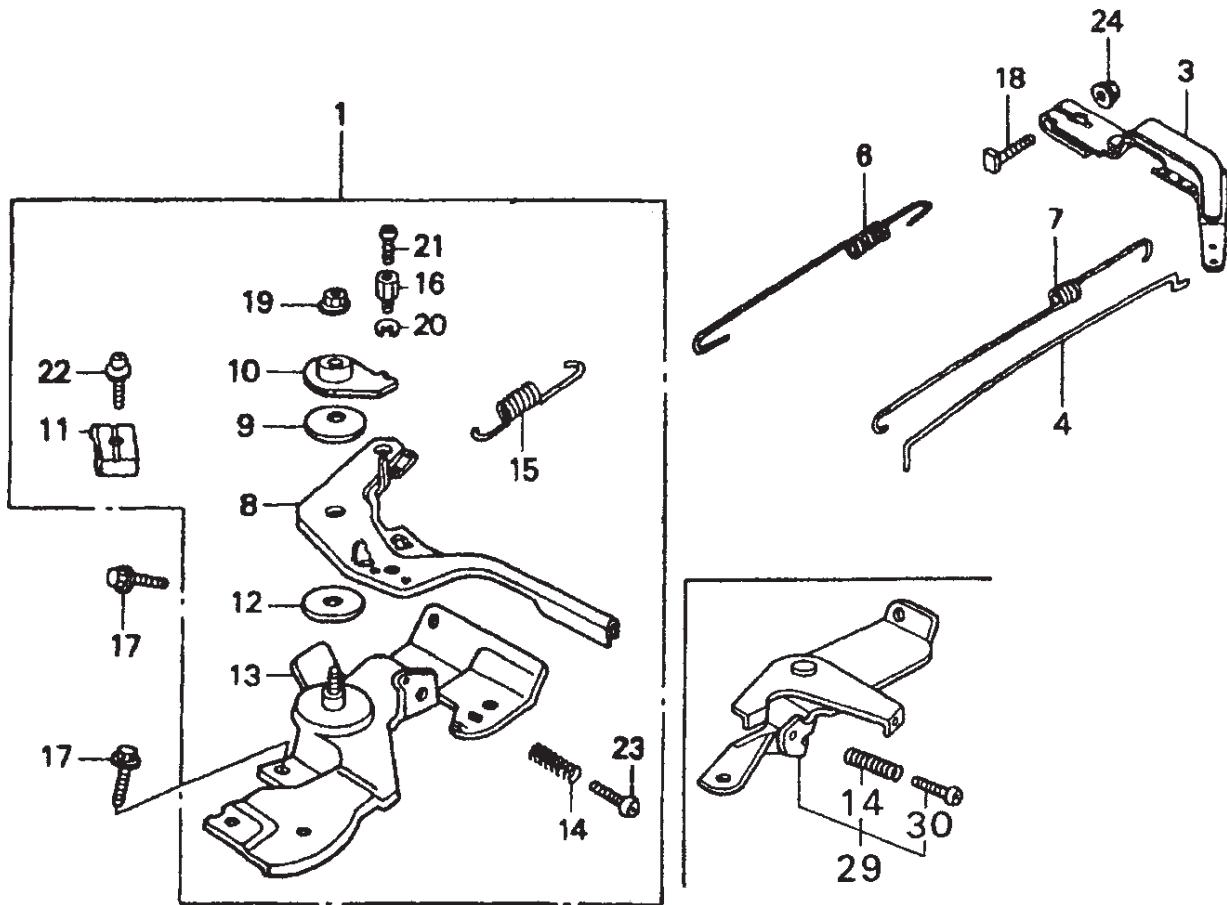

HONDA GX200 ENGINE — CONTROL ASSY.

CONTROL ASSY.

<u>NO</u>	<u>PART NO</u>	<u>PART NAME</u>	<u>QTY.</u>	<u>REMARKS</u>
1	16500ZH8812	CONTROL ASSY.	1	INCLUDES ITEMS W/*
3	16551ZL000	GOVERNOR ARM	1	
4	16555ZE1000	GOVERNOR ROD	1	
6	16561ZL0000	GOVERNOR SPRING	1	
7	16562ZE1020	SPRING THROTTLE	1	
8*	16571ZH8020	LEVER CONTROL	1	
9*	16574ZE1000	LEVER SPRING	1	
10*	16575ZH8000	WASHER CONTROL LEVER	1	
11*	16576891000	HOLDER CABLE	1	
12*	16578ZE1000	SPACER CONTROL LEVER	1	
13*	16580ZH8813	CONTROL BASE COMP	1	
14*#	16584883300	ADJUSTING SPRING	1	
15*	16592ZE1810	SPRING CABLE RETURN	1	
16*	16594883010	WIRE HOLDER	1	
17	90013883000	FLANGE BOLT 6X12	2	
18	90015ZE5010	BOLT GOVERNOR ARM	1	
19*	90114SA0000	LOCK NUT 6MM	1	
20*	90605230000	CIR CLIP	1	
21*	93500040060H	SCREW 4X6	1	
22*	93500050160A	SCREW 5X16	1	
23*	93500050250H	SCREW 5X25	1	
24	9405006000	FLANGE NUT 6MM	1	
29	16570ZB2000	CONTROL ASSY.	1	INCLUDES ITEMS W/#
30#	93500050350A	SCREW 5X35	1	

ROBIN DY23-2D ENGINE — CRANKCASE ASSY.

CRANKCASE ASSY.

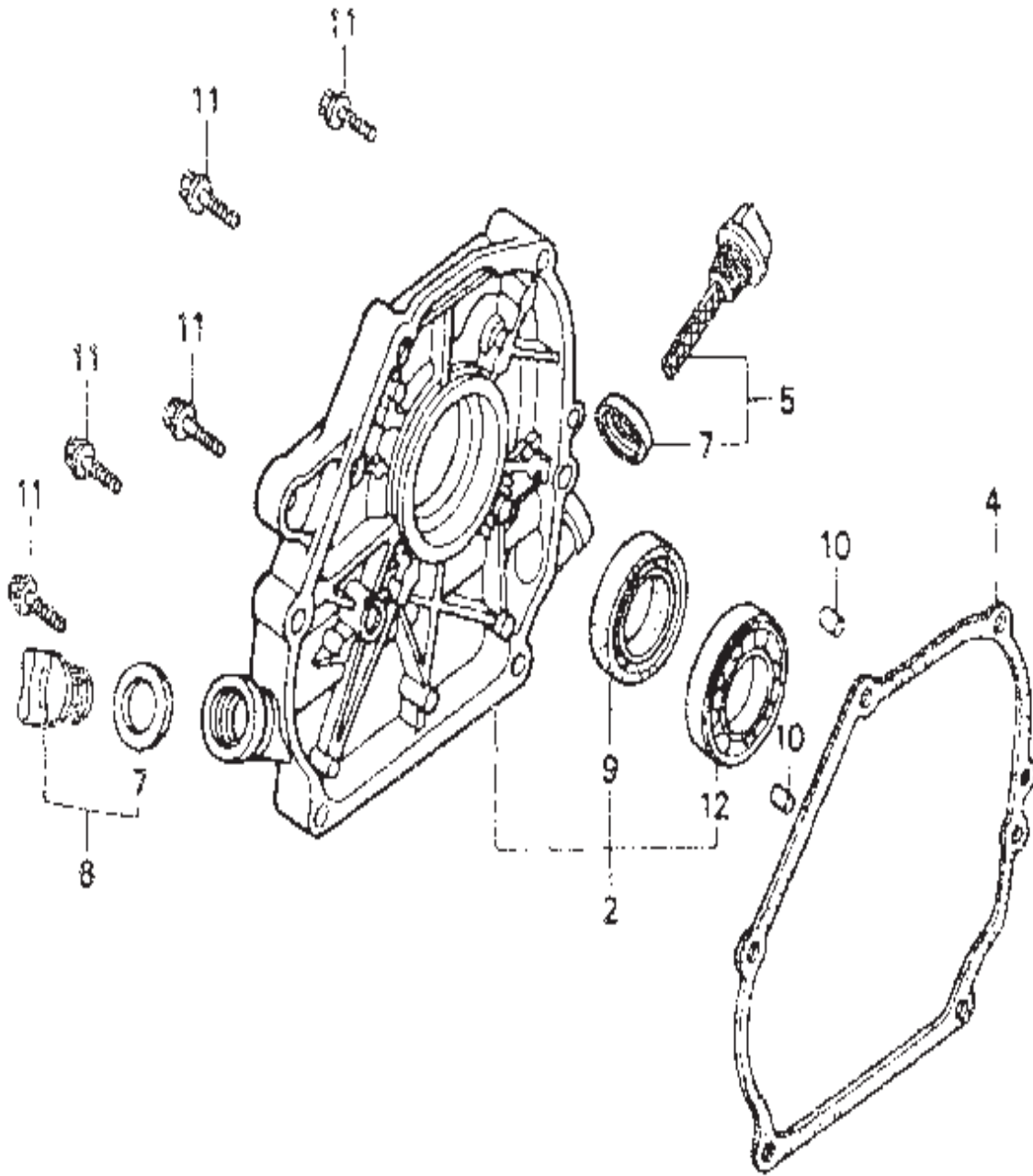

ROBIN DY23-2D ENGINE — CRANKCASE ASSY.

CRANKCASE ASSY.

<u>NO</u>	<u>PART NO</u>	<u>PART NAME</u>	<u>QTY.</u>	<u>REMARKS</u>
10	2431010151	CRANKCASE CP	1	INCLUDES ITEMS W/*
30*	0440300060	OIL SEAL	1	TB30488
40*	0600170040	BALL BEARING	1	BB6003C3
50*	0052608180	DOWEL PIN	2	
60*	0013706221	STUD	3	
70*	0440080030	OIL SEAL	1	
80	0401140030	PLUG	2	
90	0211140020	GASKET	2	
110*	0310060010	DOWEL PIN	2	
120*	0310050010	DOWEL PIN	1	
130*	2441600111	TENSION BOLT CP	3	
140*	2441600211	TENSION BOLT CP	1	
210	2441100901	MAIN BEARING COVER CP	1	INCLUDES ITEMS W/#
	2431101031	DY232YR0000	1	
220#	0440300030	OIL SEAL	1	30DX45DX8B
	0440250020	DY232YR0000	1	25X41.24X7.3
240#	0600170040	BALL BEARING	1	BB6003C3
250#	2434501107	GOVERNOR GEAR SET	1	
260	2054190103	GOVERNOR SLEEVE	1	
290	2431502603	GASKET BEARING COVER	1	
300	0011308350	BOLT AND WASHER ASSY.	12	
310	0011308400	BOLT AND WASHER ASSY.	1	
320#	2431580103	MAIN BEARING	1	STD
	2431580203	MAIN BEARING	1	UNDER SIZE 0.25
	2431580303	MAIN BEARING	1	UNDER SIZE 0.50
330	2204160103	FLYWEIGHT	2	
340	0307300070	PIN	2	
360#	2121500813	BLIND PLUG	1	

ROBIN DY23-2D ENGINE — CYLINDER HEAD ASSY.

CYLINDER HEAD ASSY.

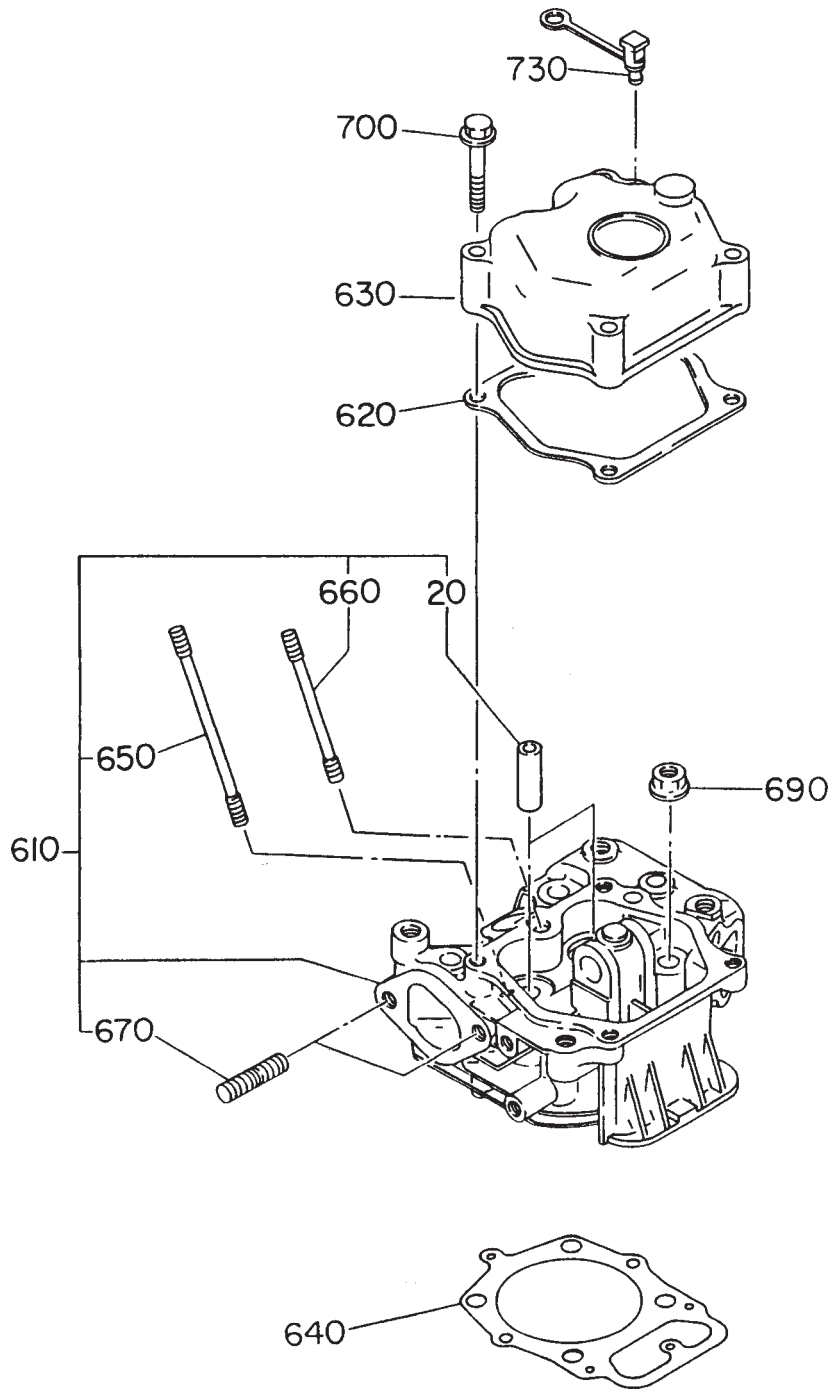

ROBIN DY23-2D ENGINE — CYLINDER HEAD ASSY.

CYLINDER HEAD ASSY.

<u>NO</u>	<u>PART NO</u>	<u>PART NAME</u>	<u>QTY.</u>	<u>REMARKS</u>
20	2431420413	VALVE GUIDE	2	OVER SIZE
610	2431300151	CYLINDER HEAD CP	1	INCLUDES ITEMS W/*
620	2431503203	GASKET ROCKER COVER	1	
630	2431710101	ROCKER COVER CP	1	
640	2431502703	GASKET HEAD	1	T=0.2
	2431502803	GASKET HEAD	1	T=0.3
650*	0105060070	STUD	1	
660*	0105060150	STUD	1	
670*	0013708201	STUD	2	
690	0180090010	FLANGE NUT	4	
700	0110060170	FLANGE BOLT	4	
730	2435501103	PLUG	1	

ROBIN DY23-2D ENGINE — CRANKSHAFT AND PISTON ASSY.

CRANKSHAFT AND PISTON ASSY.

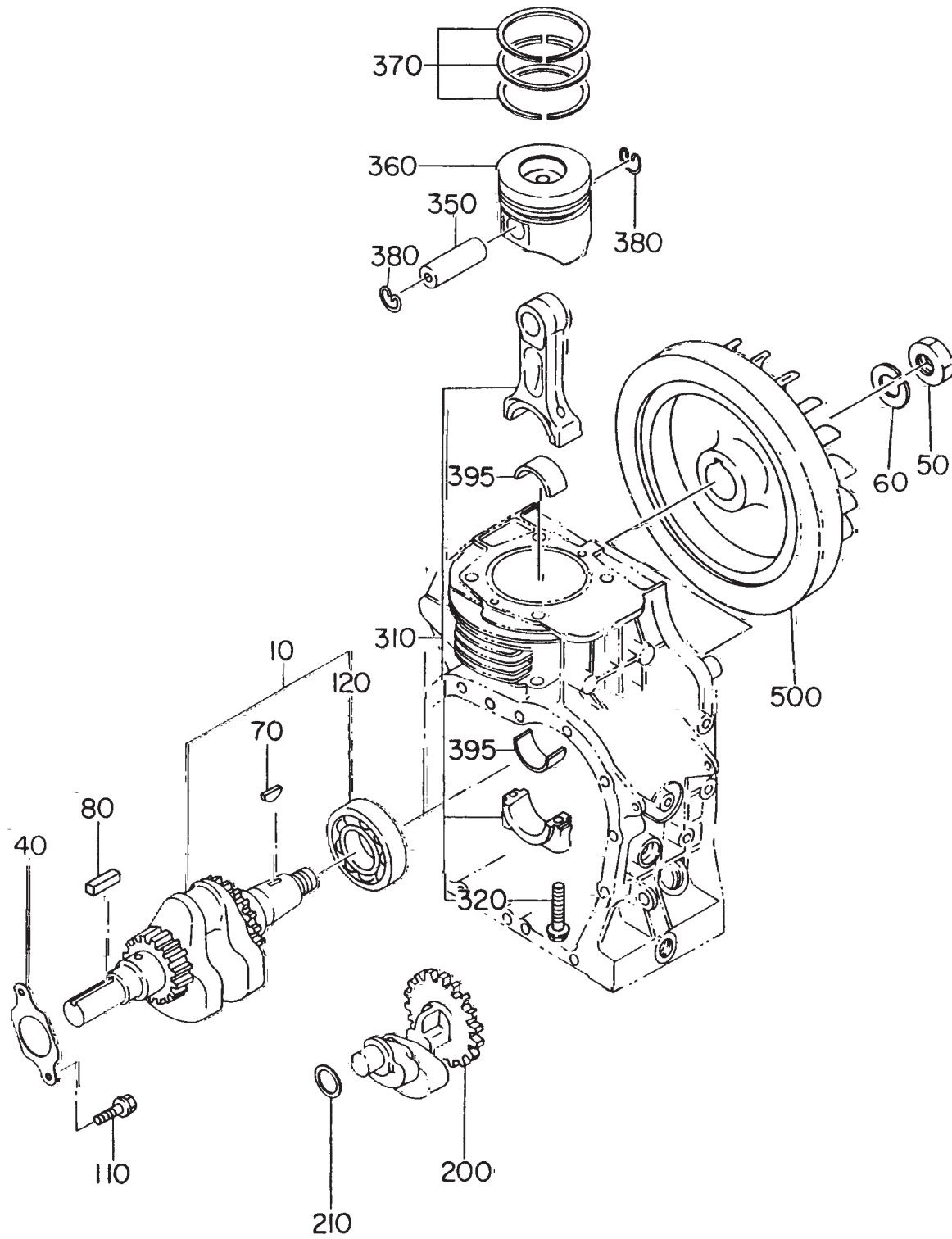

ROBIN DY23-2D ENGINE — CRANKSHAFT AND PISTON ASSY.

CRANKSHAFT AND PISTON ASSY.

<u>NO</u>	<u>PART NO</u>	<u>PART NAME</u>	<u>QTY.</u>	<u>REMARKS</u>
10	2442040111	CRANKSHAFT	1	INCLUDES ITEMS W/*
	2432060111	CRANKSHAFT	1	
40	2432500103	THRUST WASHER, T=.8	1	
	2432500203	THRUST WASHER, T=1.0	1	
	2432500303	THRUST WASHER, T=1.2	1	
50	0021818000	NUT	1	
60	0032018000	SPRING WASHER	1	
70	0323030010	WOODRUFF KEY	1	
80	2072600103	KEY	1	
110	0110060010	FLANG BOLT	2	
120*	0600350020	BALL BEARING	1	
200	2432430101	BALANCER CP	1	
210	0230170020	SPACER, T=.8	1	
	0230170030	SPACER, T=1.0	1	
	0230170040	SPACER, T=1.2	1	
310	2432251000	CONNECTING ROD ASSY.	1	INCLUDES ITEMS W/#
320#	2432300203	CONNECTING ROD BOLT	2	
350	2432330103	PISTON PIN	1	
360	2432340113	PISTON,STD	1	
	2432340213	PISTON, OVERSIZED .25MM	1	
	2432340313	PISTON, OVERSIZED .50MM	1	
370	2432350127	PISTON RING SET, STD	1	
	2432350227	PISTON RING SET, OVERSIZED .25MM	1	
	2432350327	PISTON RING SET, OVERSIZED .50MM	1	
380	0565200030	CLIP	2	
395	2432280103	LARGE END BEARING, STD	2	
	2432280203	LARGE END BEARING, UNDERSIZED .25MM	2	
	2432280303	LARGE END BEARING, UNDER SIZE 50 MM	2	
500	2432241013	FLYWHEEL	1	

ROBIN DY23-2D ENGINE — INTAKE AND EXHAUST ASSY.

INTAKE AND EXHAUST ASSY.

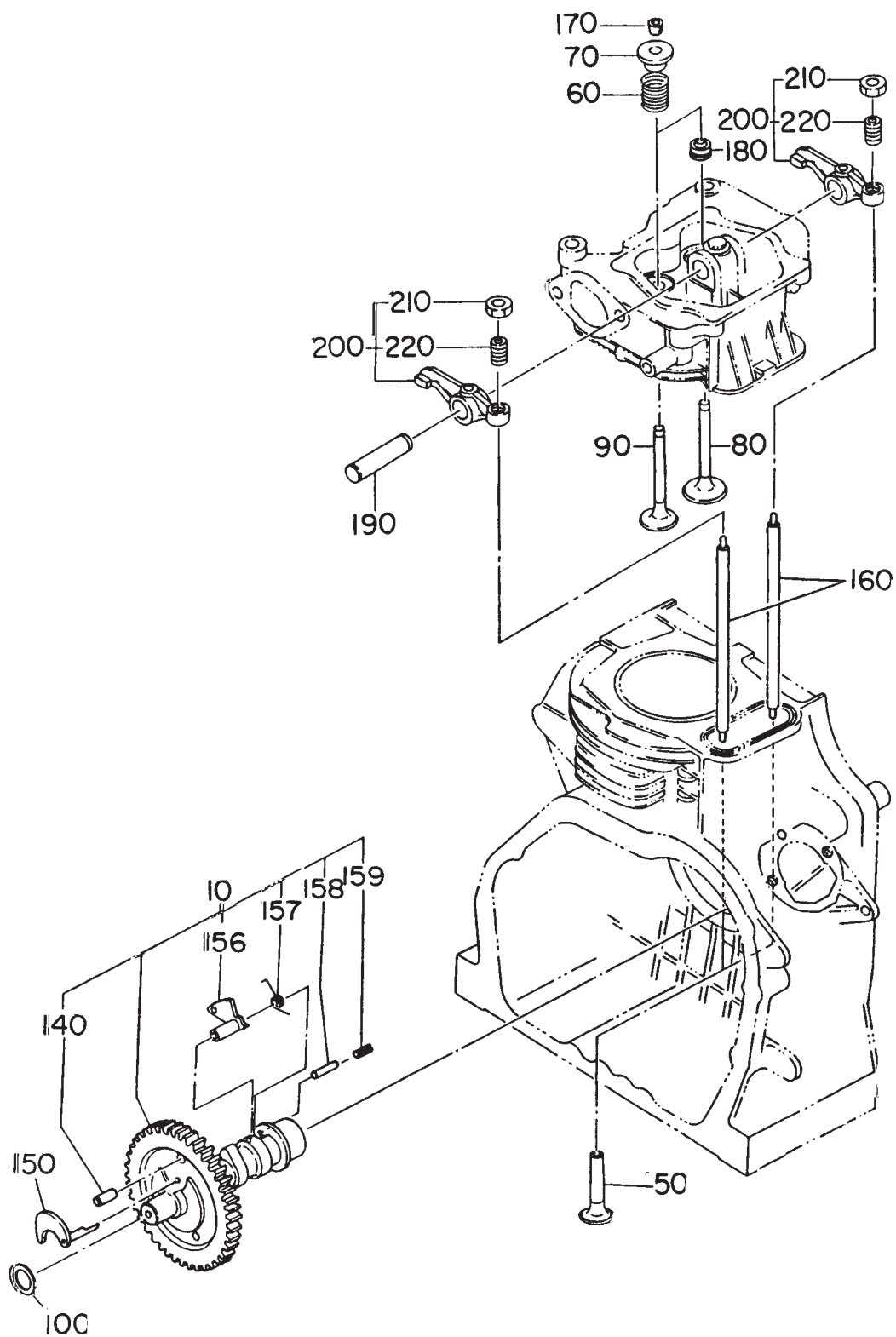

ROBIN DY23-2D ENGINE — INTAKE AND EXHAUST ASSY.

INTAKE AND EXHAUST ASSY.

<u>NO</u>	<u>PART NO</u>	<u>PART NAME</u>	<u>QTY.</u>	<u>REMARKS</u>
10	2433170221	CAMSHAFT CP	1	INCLUDES ITEMS W/*
50	2433330103	TAPPET	2	
60	2433360103	VALVE SPRING	2	
70	2433370113	SPRING RETAILER	2	
80	2433340123	INTAKE VALVE	1	
90	2433350123	EXHAUST VALVE	1	
100	0230160020	SPACER	1	T=0.8
	0230160031	SPACER	1	T=1.0
140*	0052608180	DOWEL PIN	1	
150	2433550313	RELEASE LEVER	1	
156*	2433550503	RELEASE LEVER	1	
157*	2433502103	SPRING RELEASE	1	
158*	2433502203	SHAFT RELEASE	1	
159*	0051903120	SPRING PIN	1	
160	2433503201	RUSH ROD CP	2	
170	2433380113	RETAINER LOCK	4	
180	2371600801	STEM SEAL	1	
190	2433503403	ROCKER SHAFT	1	
200	2433600201	ROCKER ARM CP	2	
210	0170080090	NUT	2	
220	0149080021	ADJUSTING SCREW	2	

ROBIN DY23-2D ENGINE — MUFFLER AND AIR CLEANER ASSY.

MUFFLER AND AIR CLEANER ASSY.

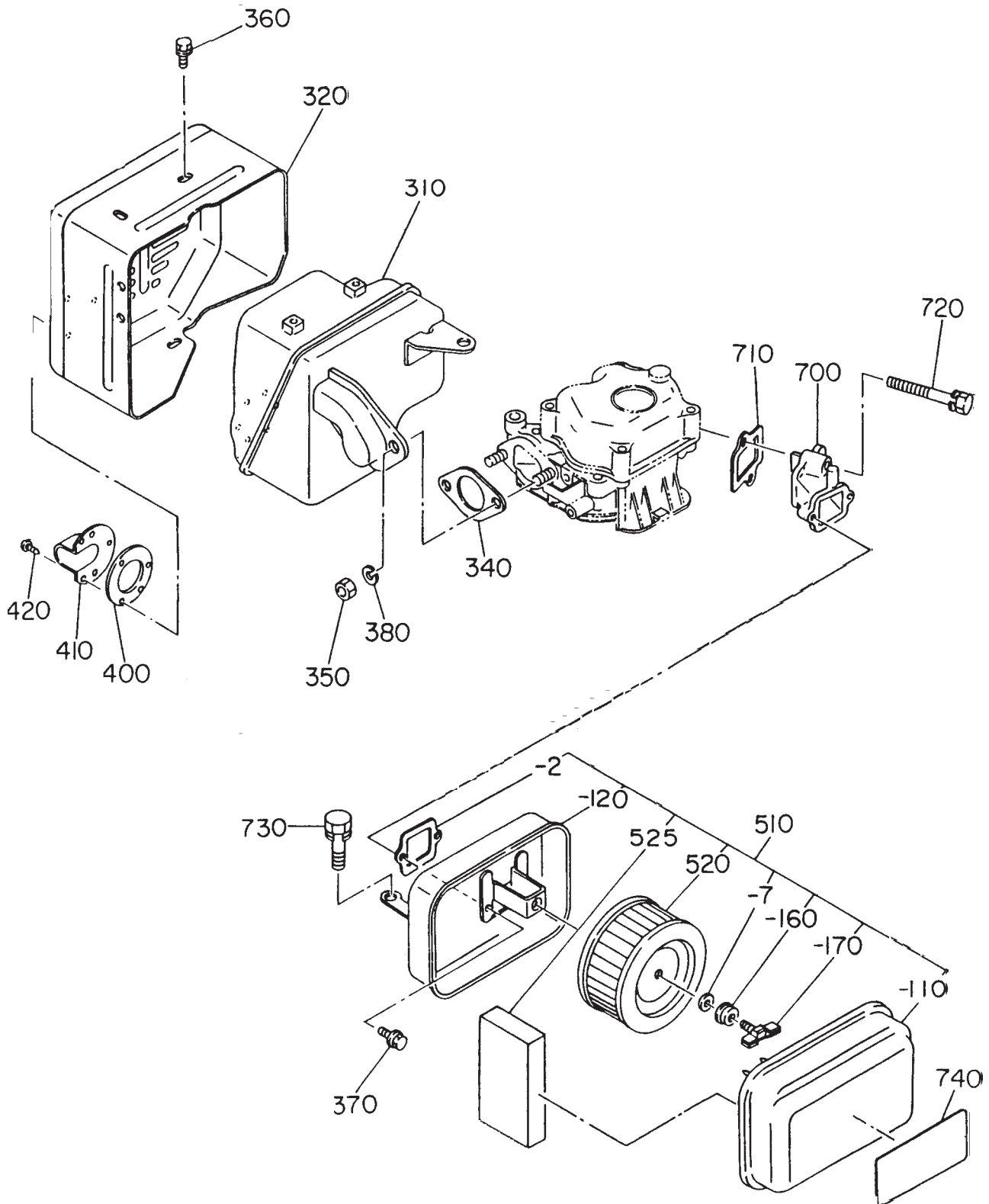

ROBIN DY23-2D ENGINE — MUFFLER AND AIR CLEANER ASSY.

MUFFLER AND AIR CLEANER ASSY.

<u>NO</u>	<u>PART NO</u>	<u>PART NAME</u>	<u>QTY.</u>	<u>REMARKS</u>
310	2433010151	MUFFLER CP	1	
320	2433420101	MUFFLER COVER CP	1	
340	2433500203	GASKET EXHAUST	1	
350	0021908000	NUT	2	
360	0011006100	BOLT AND WASHER ASSY.	4	
370	0011306120	BOLT AND WASHER ASSY.	2	
380	0032008000	SPRING WASHER	2	
400	2433500523	GASKET TAIL PIPE	1	
410	2433700211	TAIL PIPE CP	1	
420	0150040040	TAPPING SCREW	3	
510	2433260100	AIR CLEANER ASSY.	1	INCLUDES ITEMS W/*
510-2*	2433265108	PACKING	1	
510-7*	2433265008	PACKING	1	
510-110*	2433264008	COVER CP	1	
510-120*	2433262008	BACK PLATE CP	1	
510-160*	2433266008	WASHER	1	
510-170*	2433267008	WING BOLT	1	
520*	2433260008	ELEMENT CP	1	
525*	2433261108	ELEMENT	1	
700	2433310113	INTAKE MANIFOLD	1	
710	2433500313	GASKET IN-MANIFOLD	1	
720	0011308350	BOLT AND WASHER ASSY.	2	
730	0011308160	BOLT AND WASHER ASSY.	1	
740	2439230203	LABEL AIR CLEANER	1	

ROBIN DY23-2D ENGINE — GOVERNOR ASSY.

GOVERNOR ASSY.

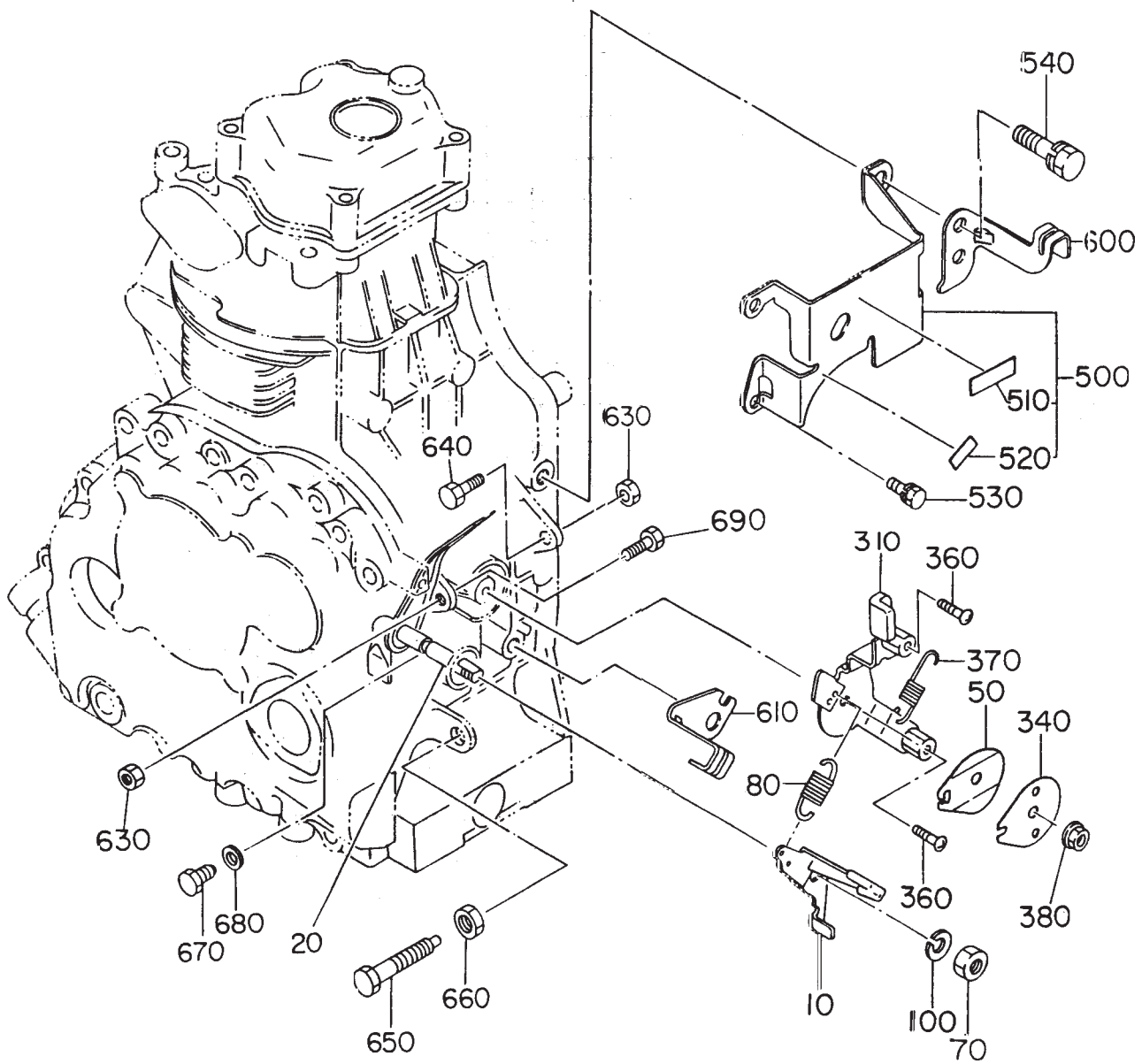

ROBIN DY23-2D ENGINE — GOVERNOR ASSY.

GOVERNOR ASSY.

<u>NO</u>	<u>PART NO</u>	<u>PART NAME</u>	<u>QTY.</u>	<u>REMARKS</u>
10	2434290221	CONTROL LINK CP	1	
20	2434230112	GOVERNOR LEVER UN	1	
50	2274500203	SPRING WASHER	1	
70	0021808000	NUT	1	
80	2434250301	GOVERNOR SPRING CP	1	
100	0032008000	SPRING WASHER	1	
310	2434330130	SPEED CONTROL ASSY.	1	
340	2274350113	STOP PLATE	1	
360	0043104100	SCREW	2	
370	2434600103	RETURN SPRING	1	
380	0176060030	SELF LOCK NUT	1	
500	2434016601	CONTROL PANEL CP	1	INCLUDES ITEMS W/*
510*	2439210103	LABEL OPERATION	1	
520*	2439210203	LABEL OPERATION	1	
530	0011306120	BOLT AND WASHER ASSY	2	
540	0011308160	BOLT AND WASHER ASSY	3	
600	2434420201	WIRE BRACKET 1	1	
610	2434421001	WIRE BRACKET 2 CP	1	
630	0021806000	NUT	2	
640	0016606300	BOLT	1	
650	2434550110	SMOKE SET ASSY.	1	
660	0022710000	NUT	1	
670	2434500203	BOLT	1	
680	0031006000	WASHER	1	
690	0100060370	BOLT	1	

ROBIN DY23-2D ENGINE — COOLING AND STARTING ASSY.

COOLING AND STARTING

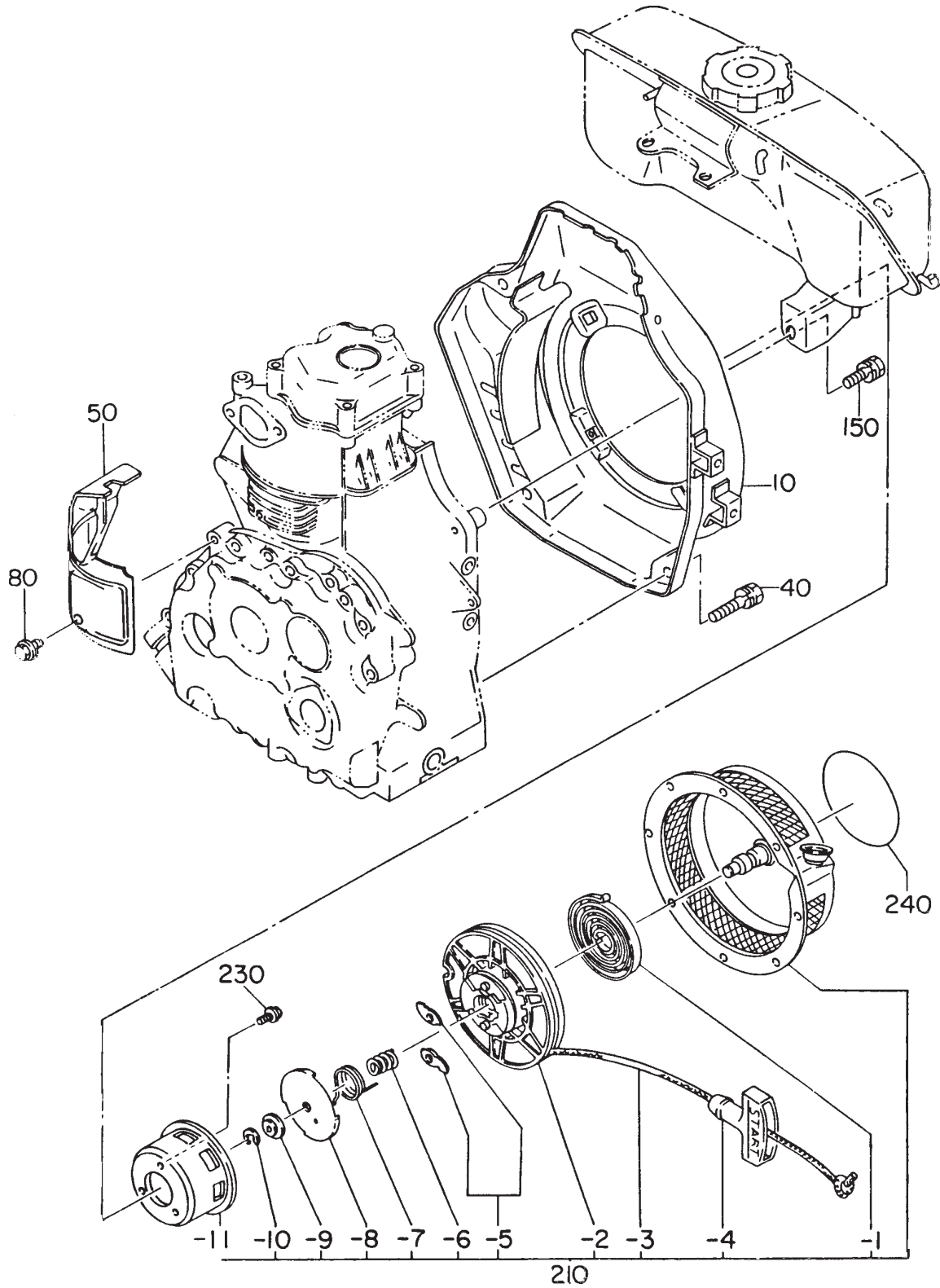

ROBIN DY23-2D ENGINE — COOLING AND STARTING ASSY.

COOLING AND STARTING ASSY.

<u>NO</u>	<u>PART NO</u>	<u>PART NAME</u>	<u>QTY.</u>	<u>REMARKS</u>
10	2435120121	BLOWER HOUSING	1	
40	0011308200	BOLT & WASHER ASSY.	2	
50	2435260133	CYLINDER BAFFLE	1	
80	0110060010	FLANFE BOLT	5	
150	0011308300	BOLT & WASHER ASSY.	2	
210	2435020120	RECOIL STARTER ASSY.	1 INCLUDES ITEMS W/*
210-1*	1065011608	SPRIAL SPRING	1	
210-2*	2395022008	REEL CP	1	
210-3*	2435011008	STARTER ROPE	1	
210-4*	2365010108	STARTER KNOB	1	
210-5*	1065012818	RATCHET	2	
210-6*	1065013208	FRICTION SPRING	1	
210-7*	1065013618	RETURN SPRING	1	
210-8*	1065014408	FRICTION PLATE	1	
210-9*	1065018508	THRUST WASHER	1	
210-10*	1065018608	CLIP	1	
210-11*	2435014508	STARTING PULLEY	1	
230	0011306120	BOLT & WASHER ASSY.	3	
240	2439500413	LABEL (DIESEL MARK)	1	

ROBIN DY23-2D ENGINE — FUEL AND LUBRICANT ASSY.

FUEL AND LUBRICANT ASSY.

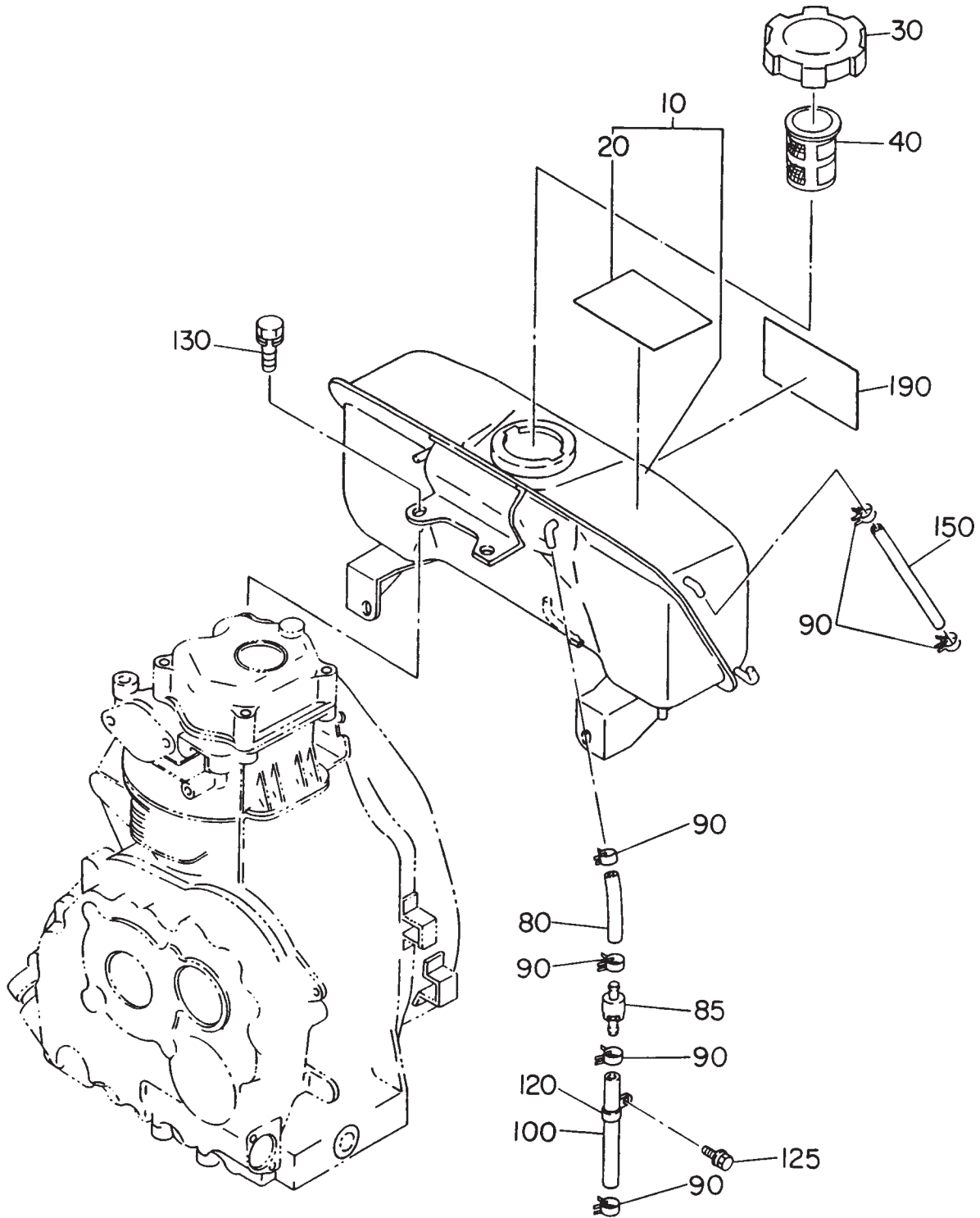

ROBIN DY23-2D ENGINE — FUEL AND LUBRICANT ASSY.

FUEL AND LUBRICANT ASSY.

<u>NO</u>	<u>PART NO</u>	<u>PART NAME</u>	<u>QTY.</u>	<u>REMARKS</u>
10	2436011621	FUEL TANK	1	INCLUDES ITEM W/*
20*	2439190713	LABEL (INSTRUCTION)	1	
30	0430430015	FUEL TANK CAP	1	
40	0641360010	FUEL FILTER	1	
80	0851450000	RUBBER PIPE 4.5X9 M	1	
85	2286503213	CHECK VALVE	1	
90	0561080010	HOSE CLAMP	5	
100	0851450000	RUBBER PIPE 4.5X9 M	1	
120	1507520103	CLAMP	1	
125	0011006100	BOLT & WASHER ASSY.	1	
130	0011308200	BOLT & WASHER ASSY.	2	
150	0850050000	VINYL PIPE 5X8 M	1	
190	2559170103	LABEL, TRADE MARK		

ROBIN DY23-2D ENGINE — FUEL SYSTEM ASSY.

FUEL SYSTEM ASSY.

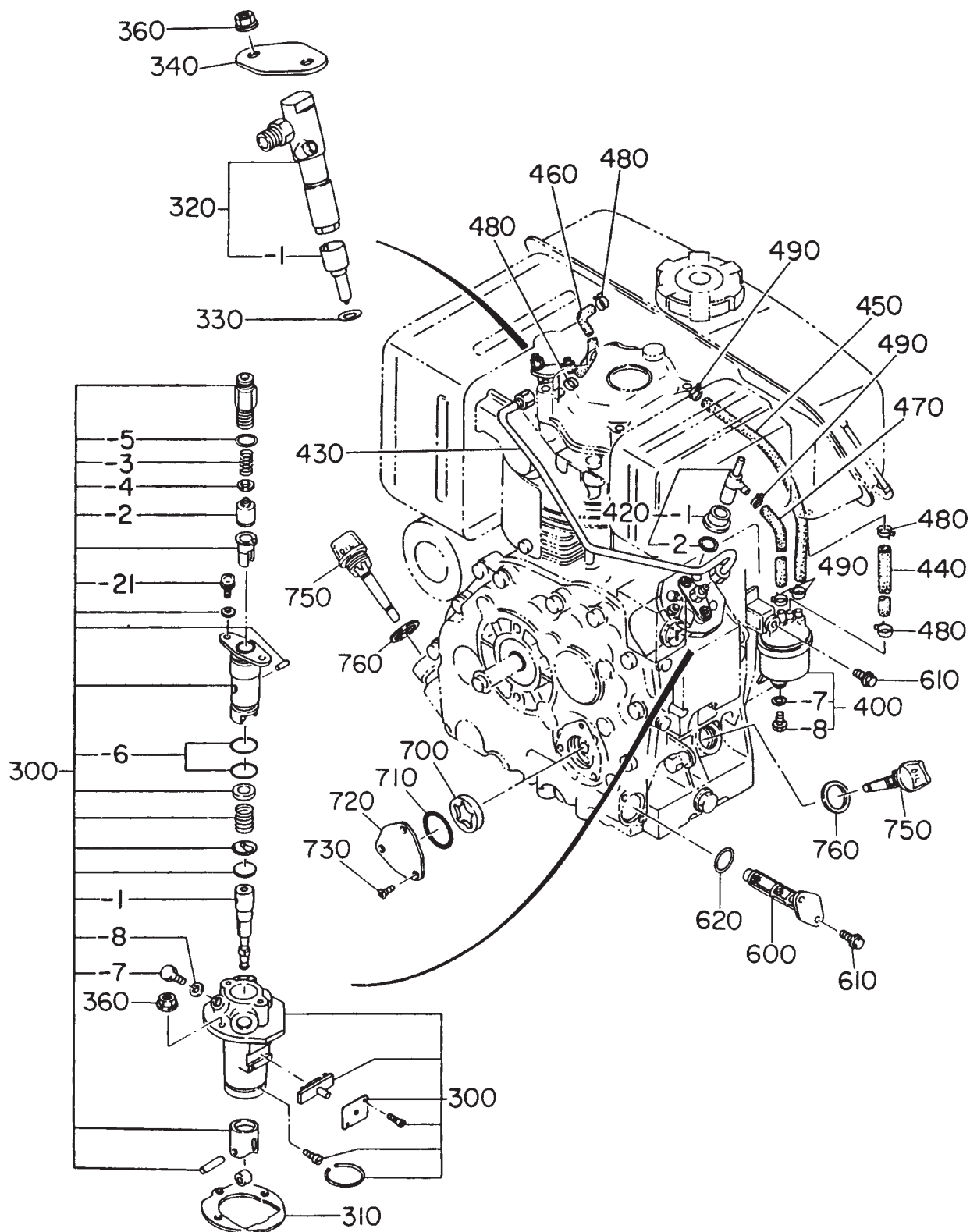

ROBIN DY23-2DD ENGINE — FUEL SYSTEM ASSY.

FUEL SYSTEM ASSY.

<u>NO</u>	<u>PART NO</u>	<u>PART NAME</u>	<u>QTY.</u>	<u>REMARKS</u>
300	2436310120	INJECTION PUMP ASSY.	1	INCLUDES ITEMS W/*
300-1*	2436312808	PLUNGER ASSY.	1	
300-2*	2436310308	DELIVERY VALVE	1	
300-3*	2436310408	DELIVERY SPRING	1	
300-4*	2436310508	GASKET	1	
300-5*	2436310708	O-RING	1	
300-6*	2436312908	O-RING	2	
300-7*	2436312408	BOLT	1	
300-8*	2436312508	GASKET	1	
300-21*	2436313008	SCREW	2	
310	2436500103	GASKET INJECTION	1	T=0.1
	2436500203	GASKET INJECTION	1	T=0.2
	2436500303	GASKET INJECTION	1	T=0.3
320	2436320100	NOZZLE ASSY.	1	INCLUDES ITEMS W/#
320-1#	2436320408	NOZZLE	1	
330	2286500403	GASKET NOZZLE	1	
340	2436600101	BRACKET CP, NOZZLE 1	1	
360	0023806000	FLANGE NUT	4	
400	2436210120	FUEL FILTER ASSY.	1	INCLUDES ITEMS W/%
400-7%	2286211208	PACKING	1	
400-8%	2286211108	PLUG	1	
420	2436652000	T-CONNECTOR ASSY.	1	INCLUDES ITEMS W/+
420-1+	2436652108	NUT	1	
420-2+	2436650608	PACKING	1	
430	2436330121	INJECTION PIPE CP	1	
440	0851450000	RUBBER PIPE	1	4.5X9XM
450	0851060000	RUBBER PIPE	1	6X12XM
460	0851450000	RUBBER PIPE	1	4.5X9XM
470	0851060000	RUBBER PIPE	1	6X12XM
480	0561080010	HOSE CLAMP	4	
490	0561110020	HOSE CLAMP	4	
600	2436430100	OIL FILTER ASSY.	1	
610	0011406160	BOLT AND WASHER ASSY.	4	
620	0062620200	O-RING	1	
700	2286390203	OIL PUMP OUTER	1	
710	0062610330	O-RING	1	
720	2436602001	COVER CP, OIL PUMP	1	
730	0041106160	SCREW, COUNTER SUNK	3	
750	2146360113	OIL GAUGE	2	
760	0213200010	GASKET	2	

ROBIN DY23-2D ENGINE —GEAR REDUCTION ASSY.

GEAR REDUCTION ASSY.

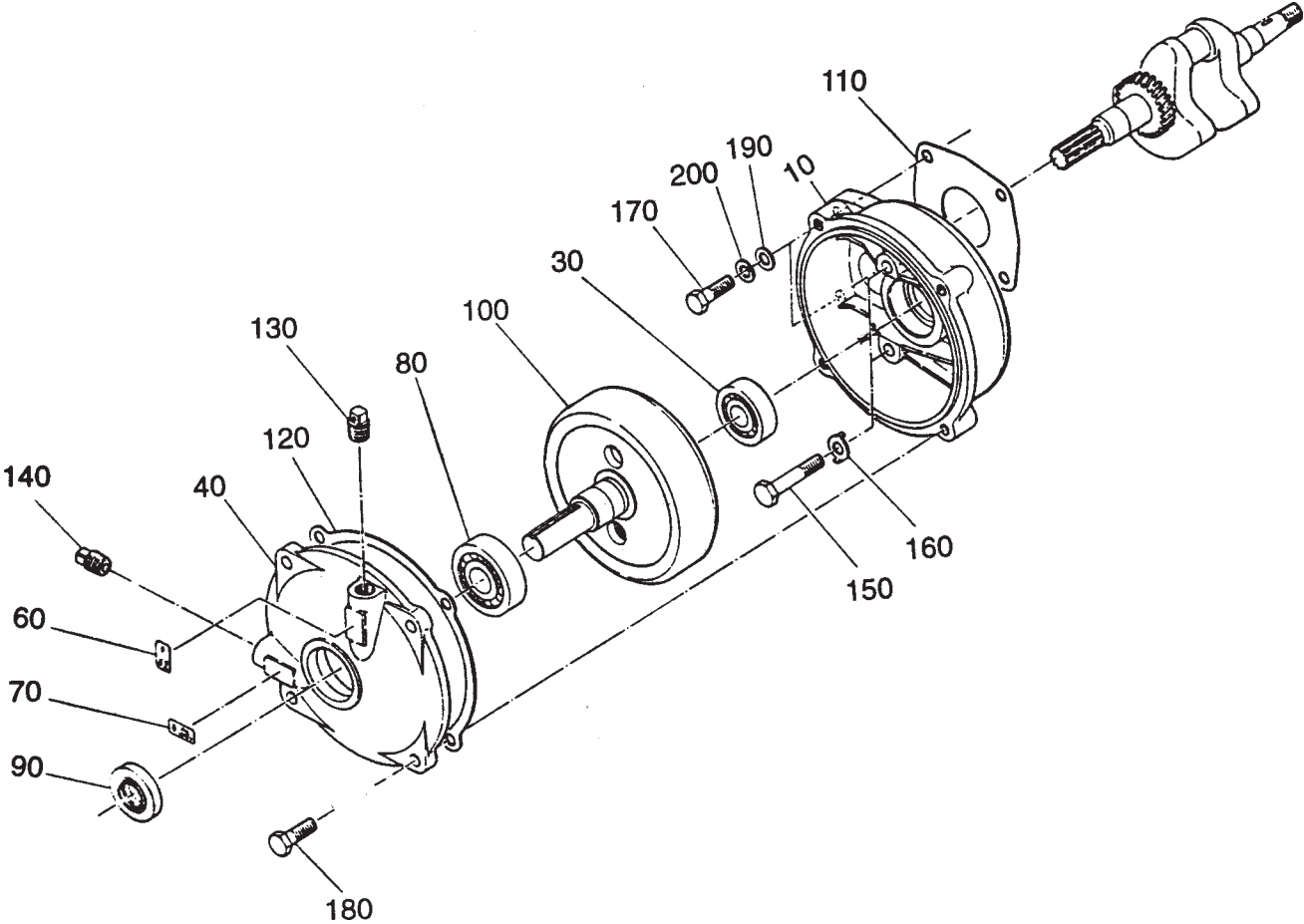

ROBIN DY23-2D ENGINE —GEAR REDUCTION ASSY.

GEAR REDUCTION ASSY.

<u>NO</u>	<u>PART NO</u>	<u>PART NAME</u>	<u>QTY.</u>	<u>REMARKS</u>
10	2078010101	REDUCTION CASE CP	1	
30	0600150020	BALL BEARING	1	
40	2078070101	REDUCTION COVER CP	1	
60	2069500103	LABEL OIL FILTER	1	
70	2069500203	LABEL LEVER MARK	1	
80	0600300020	BALL BEARING	1	
90	0440300030	OIL SEAL	1	
100	2078110103	DRIVING SHAFT	1	
110	2068510103	GASKET A	1	
120	2068510203	GASKET B	1	
130	2068500103	PLUG A	1	
140	2068500203	PLUG B	1	
150	0101080030	BOLT	2	
160	0033808000	LOCK WASHER	2	
170	0101080080	BOLT	2	
180	0011408250	BOLT AND WASHER ASSY.	4	
190	0031008000	WASHER	2	
200	0032008000	SPRING WASHER	2	

PAYMENT TERMS

Terms of payment for parts are net 30 days.

FREIGHT POLICY

All parts orders will be shipped collect or prepaid with the charges added to the invoice. All shipments are F.O.B. point of origin. Multiquip's responsibility ceases when a signed manifest has been obtained from the carrier, and any claim for shortage or damage must be settled between the consignee and the carrier.

MINIMUM ORDER

The minimum charge for orders from Multiquip is \$15.00 net. Customers will be asked for instructions regarding handling of orders not meeting this requirement.

RETURNED GOODS POLICY

Return shipments will be accepted and credit will be allowed, subject to the following provisions:

1. A Returned Material Authorization must be approved by Multiquip prior to shipment.
2. To obtain a Return Material Authorization, a list must be provided to Multiquip Parts Sales that defines item numbers, quantities, and descriptions of the items to be returned.
 - a. The parts numbers and descriptions must match the current parts price list.
 - b. The list must be typed or computer generated.
 - c. The list must state the reason(s) for the return.
 - d. The list must reference the sales order(s) or invoice(s) under which the items were originally purchased.
 - e. The list must include the name and phone number of the person requesting the RMA.
3. A copy of the Return Material Authorization must accompany the return shipment.
4. Freight is at the sender's expense. All parts must be returned freight prepaid to Multiquip's designated receiving point.

5. Parts must be in new and resalable condition, in the original Multiquip package (if any), and with Multiquip part numbers clearly marked.

6. The following items are not returnable:

- a. Obsolete parts. (If an item is in the price book and shows as being replaced by another item, it is obsolete.)
- b. Any parts with a limited shelf life (such as gaskets, seals, "O" rings, and other rubber parts) that were purchased more than six months prior to the return date.
- c. Any line item with an extended dealer net price of less than \$5.00.
- d. Special order items.
- e. Electrical components.
- f. Paint, chemicals, and lubricants.
- g. Decals and paper products.
- h. Items purchased in kits.

7. The sender will be notified of any material received that is not acceptable.

8. Such material will be held for five working days from notification, pending instructions. If a reply is not received within five days, the material will be returned to the sender at his expense.

9. Credit on returned parts will be issued at dealer net price at time of the original purchase, less a 15% restocking charge.

10. In cases where an item is accepted, for which the original purchase document can not be determined, the price will be based on the list price that was effective twelve months prior to the RMA date.

11. Credit issued will be applied to future purchases only.

PRICING AND REBATES

Prices are subject to change without prior notice. Price changes are effective on a specific date and all orders received on or after that date will be billed at the revised price. Rebates for price declines and added charges for price increases will not be made for stock on hand at the time of any price change.

Multiquip reserves the right to quote and sell direct to Government agencies, and to Original Equipment Manufacturer accounts who use our products as integral parts of their own products.

SPECIAL EXPEDITING SERVICE

A \$35.00 surcharge will be added to the invoice for special handling including bus shipments, insured parcel post or in cases where Multiquip must personally deliver the parts to the carrier.

LIMITATIONS OF SELLER'S LIABILITY

Multiquip shall not be liable hereunder for damages in excess of the purchase price of the item with respect to which damages are claimed, and in no event shall Multiquip be liable for loss of profit or good will or for any other special, consequential or incidental damages.

LIMITATION OF WARRANTIES

No warranties, express or implied, are made in connection with the sale of parts or trade accessories nor as to any engine not manufactured by Multiquip. Such warranties made in connection with the sale of new, complete units are made exclusively by a statement of warranty packaged with such units, and Multiquip neither assumes nor authorizes any person to assume for it any other obligation or liability whatever in connection with the sale of its products. Apart from such written statement of warranty, there are no warranties, express, implied or statutory, which extend beyond the description of the products on the face hereof.

OPERATION AND PARTS MANUAL

HERE'S HOW TO GET HELP

PLEASE HAVE THE MODEL AND SERIAL
NUMBER *ON-HAND* WHEN CALLING

UNITED STATES

Multiquip Corporate Office

18910 Wilmington Ave. Tel. (800) 421-1244
Carson, CA 90746 Fax (800) 537-3927
Contact: mq@multiquip.com

Mayco Parts

800-306-2926 Fax: 800-672-7877
310-537-3700 Fax: 310-637-3284

Service Department

800-421-1244 Fax: 310-537-4259
310-537-3700

MQ Parts Department

800-427-1244 Fax: 800-672-7877
310-537-3700 Fax: 310-637-3284

Warranty Department

800-421-1244, Ext. 279 Fax: 310-537-1173
310-537-3700, Ext. 279

Technical Assistance

800-478-1244 Fax: 310-631-5032

MEXICO

MQ Cipsa

Carr. Fed. Mexico-Puebla KM 126.5 Tel: (52) 222-225-9900
Momoxpan, Cholula, Puebla 72760 Mexico Fax: (52) 222-285-0420
Contact: pmastretta@cipsa.com.mx

CANADA

Multiquip

4110 Industriel Boul. Tel: (450) 625-2244
Laval, Quebec, Canada H7L 6V3 Fax: (450) 625-8664
Contact: jmartin@multiquip.com

UNITED KINGDOM

Multiquip (UK) Limited Head Office

Hanover Mill, Fitzroy Street, Tel: 0161 339 2223
Ashton-under-Lyne, Fax: 0161 339 3226
Lancashire OL7 0TL
Contact: sales@multiquip.co.uk

BRAZIL

Multiquip

Av. Evandro Lins e Silva, 840 - grupo 505 Tel: 011-55-21-3433-9055
Barra de Tijuca - Rio de Janeiro Fax: 011-55-21-3433-9055
Contact: cnavarro@multiquip.com.br, srentes@multiquip.com.br

© COPYRIGHT 2006, MULTIQUIP INC.

Multiquip Inc. and the MQ logo are registered trademarks of Multiquip Inc. and may not be used, reproduced, or altered without written permission. All other trademarks are the property of their respective owners and used with permission.

This manual MUST accompany the equipment at all times. This manual is considered a permanent part of the equipment and should remain with the unit if resold.

The information and specifications included in this publication were in effect at the time of approval for printing. Illustrations are based on the *MQ Mikasa MVH-150GH/D Reversible Plate Compactor*. Illustrations, descriptions, references and technical data contained in this manual are for guidance only and may not be considered as binding. Multiquip Inc. reserves the right to discontinue or change specifications, design or the information published in this publication at any time without notice and without incurring any obligations.

Your Local Dealer is:

