

OPERATION MANUAL



MODEL ST4125G/ST6125G SUBMERSIBLE PUMP

Revision #0 (11/18/10)

To find the latest revision of this
publication, visit our website at:
www.multiquip.com



THIS MANUAL MUST ACCOMPANY THE EQUIPMENT AT ALL TIMES.

**ST4125G/ST6125G
Submersible Pump**

Table Of Contents..... 2
Parts Ordering Procedures..... 3
Safety Information 4-7
Specifications..... 8
Dimensions..... 9
General Information 10
Components 11
Float Switches 12-14
Control Box Installation 15-16
230/460 Vac Voltage Selection 17
Control Box Power Connections 18
Control Box Wiring Layout 19
Operation 20-21
Maintenance 22-25
Control Box Wiring Diagram 26

SAFETY INFORMATION

Do not operate or service the equipment before reading the entire manual. Safety precautions should be followed at all times when operating this equipment. Failure to read and understand the safety messages and operating instructions could result in injury to yourself and others.



SAFETY MESSAGES

The four safety messages shown below will inform you about potential hazards that could injure you or others. The safety messages specifically address the level of exposure to the operator and are preceded by one of four words: **DANGER**, **WARNING**, **CAUTION** or **NOTICE**.

SAFETY SYMBOLS

! **DANGER**

Indicates a hazardous situation which, if not avoided, **WILL** result in **DEATH** or **SERIOUS INJURY**.

! **WARNING**

Indicates a hazardous situation which, if not avoided, **COULD** result in **DEATH** or **SERIOUS INJURY**.

! **CAUTION**

Indicates a hazardous situation which, if not avoided, **COULD** result in **MINOR** or **MODERATE INJURY**.

NOTICE

Addresses practices not related to personal injury.

Potential hazards associated with the operation of this equipment will be referenced with hazard symbols which may appear throughout this manual in conjunction with safety messages.

Symbol	Safety Hazard
	Burn hazards
	Electric shock hazards
	Rotating parts hazards
	Pressurized fluid hazards

SAFETY INFORMATION

GENERAL SAFETY

CAUTION

- **NEVER** operate this equipment without proper protective clothing, shatterproof glasses, respiratory protection, hearing protection, steel-toed boots and other protective devices required by the job or city and state regulations.



- Avoid wearing jewelry or loose fitting clothes that may snag on the controls or moving parts as this can cause serious injury.
- **NEVER** operate this equipment when not feeling well due to fatigue, illness or when under medication.
- **NEVER** operate this equipment under the influence of drugs or alcohol.



- **ALWAYS** clear the work area of any debris, tools, etc. that would constitute a hazard while the equipment is in operation.
- No one other than the operator is to be in the working area when the equipment is in operation.
- **DO NOT** use the equipment for any purpose other than its intended purposes or applications.

NOTICE

- This equipment should only be operated by trained and qualified personnel 18 years of age and older.
- Whenever necessary, replace nameplate, operation and safety decals when they become difficult read.
- Manufacturer does not assume responsibility for any accident due to equipment modifications. Unauthorized equipment modification will void all warranties.
- **NEVER** use accessories or attachments that are not recommended by Multiquip for this equipment. Damage to the equipment and/or injury to user may result.
- **ALWAYS** know the location of the nearest **fire extinguisher**.
- **ALWAYS** know the location of the nearest **first aid kit**.
- **ALWAYS** know the location of the nearest phone or **keep a phone on the job site**. Also, know the phone numbers of the nearest **ambulance, doctor and fire department**. This information will be invaluable in the case of an emergency.



SAFETY INFORMATION

PUMP SAFETY

DANGER

- **NEVER** operate the equipment in an explosive atmosphere or near combustible materials. An explosion or fire could result causing severe **bodily harm or even death.**



WARNING

- Accidental starting can cause severe injury or death. **ALWAYS** place the ON/OFF switch in the OFF position.
- **DO NOT** place hands or fingers inside pump when pump is running.
- **NEVER** disconnect any **emergency or safety devices.** These devices are intended for operator safety. Disconnection of these devices can cause severe injury, bodily harm or even death. Disconnection of any of these devices will void all warranties.
- Risk of Electric Shock - This pump has not been investigated for use in swimming pool or marine areas.



CAUTION

- **DO NOT** restrict the flow of the discharge hose as it may cause the pump to overheat.
- Be careful of discharge hose whipping under pressure.
- **ALWAYS** check pump oil level only when pump is cool. Expansion due to heat may cause hot oil to spray from the oil plug when the oil plug is removed. The possibility of severe scalding may exist.

NOTICE

- **ALWAYS** place the pump in an upright position on a platform before using. The platform will prevent the pump from burrowing itself on soft sand or mud.
- **NEVER** operate pump on its side.
- **DO NOT** allow the pump to freeze in water.
- **NEVER** leave an open pump chamber unattended.
- **ALWAYS** keep the machine in proper running condition.
- **DO NOT** attempt to thaw out a frozen pump by using

a torch or other source of flame. Application of heat in this manner may heat the oil in the seal cavity above the critical point, causing pump damage.

- **DO NOT** pump water with a temperature greater than 104°F.
- **DO NOT** pump liquids containing acid or alkali.
- **ALWAYS** check strainer before pumping. Make sure strainer is not clogged. Remove any large objects, dirt or debris from the strainer to prevent clogging.
- **ALWAYS** use a large basket strainer when pumping water that contains large debris.
- **ALWAYS** flush pump (clean) after use when pumping water concentrated with heavy debris. It is very important to always flush the pump before turning it off to prevent clogging.
- Fix damage to machine and replace any broken parts immediately.
- **ALWAYS** store equipment properly when it is not being used. Equipment should be stored in a clean, dry location out of the reach of children and unauthorized personnel.
- **NEVER** lubricate components or attempt service on a running machine.
- **NEVER** run pump *dry*.
- **ALWAYS** allow the machine a proper amount of time to cool before servicing.
- Keep machine in proper running condition.

ELECTRICAL SAFETY

DANGER

- The electrical voltage required to operate pump can cause severe injury or even death through physical contact with live circuits. **ALWAYS** disconnect electrical power from pump before performing maintenance on pump.



WARNING

- To reduce the risk of electric shock, connect only to a circuit protected by a Ground-Fault Circuit-Interrupter (GFCI).

SAFETY INFORMATION

NOTICE

- **ALWAYS** make certain that the voltage supplied to the pump is correct. Always read the pump's nameplate to determine what the power requirements are.

Power Cord/Cable Safety

DANGER

- **NEVER** let power cords or cables lay in water.
- **NEVER** stand in water while AC power cord is connected to a live power source.
- **NEVER** use **damaged** or **worn** cables or cords. Inspect for cuts in the insulation.
- **NEVER** grab or touch a live power cord or cable with wet hands. The possibility exists of **electrical shock, electrocution or death.**

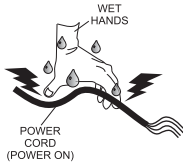

- Make sure power cables are securely connected to the motor's output receptacles. Incorrect connections may cause electrical shock and damage to the motor.

WARNING

- **NEVER** attempt to use the power cord as a lifting or lowering device for the pump.

NOTICE

- **ALWAYS** make certain that proper power or extension cord has been selected for the job. See Cable Selection Chart in this manual.

Grounding Safety

DANGER

- **ALWAYS** make sure pump is grounded.
- **NEVER** use gas piping as an electrical ground.
- **ALWAYS** make sure that electrical circuits are properly grounded to a suitable earth ground (ground rod) per the National Electrical Code (NEC) and local codes before operating generator. **Severe injury or death by electrocution** can result from operating an ungrounded motor.

Control Box Safety

DANGER

- **ALWAYS** have a qualified electrician perform the control box installation. The possibility exists of electrical shock or electrocution.

NOTICE

- **ALWAYS** mount control box in a vertical position protected from harsh environmental elements.

LIFTING SAFETY

CAUTION

- When raising or lowering of the pump is required, always attach an adequate rope or lifting device to the correct lifting point (handle) on the pump.

NOTICE

- **DO NOT** lift machine to unnecessary heights.
- **NEVER** lift the equipment while the electric motor is running.

TRANSPORTING SAFETY

NOTICE

- **ALWAYS** shut down pump before transporting.
- **ALWAYS** tie down equipment during transport by securing the equipment with rope.

ENVIRONMENTAL SAFETY/DECOMMISSIONING

- **DO NOT** pour waste or oil directly onto the ground, down a drain or into any water source.
- Contact your country's Department of Public Works or recycling agency in your area and arrange for proper disposal of any electrical components, waste or oil associated with this equipment.
- When the life cycle of this equipment is over it is recommended that the pump casing and all other metal parts be sent to a recycling center



Metal recycling involves the collection of metal from discarded products and its transformation into raw materials to use in manufacturing a new product.

Recyclers and manufacturers alike promote the process of recycling metal. Using a metal recycling center promotes energy cost savings.

ST4125G/ST6125G SUBMERSIBLE PUMP — SPECIFICATIONS

Table 1. Specifications		
Model	ST4125G	ST6125G
Type	Centrifugal Submersible Pump	Centrifugal Submersible Pump
Impeller	Cast Ductile Iron	Cast Ductile Iron
Discharge Size	4.00 in. (101 mm)	6.00 in. (152 mm)
Max Solids	.078 in (2 mm)	.078 in (2 mm)
Maximum Pumping Capacity	380 gallons/minute (1,438 liters/minute)	TBD
Max Head	111 ft. (33.8 meters)	TBD
Power	10 HP (7.5 kw)	15 HP (11 kw)
Voltage/Phase	230/460 3Ø	230/460 3Ø
Starting Amps	180 (230V) 90 (460V)	TBD
Running Amps	24 (230V) 12 (460V)	TBD
Max Starts/Hr.	30	30
Enclosure Type	68	68
Insulation Class	F	F
Max Temperature	104° F (40° C)	104° F (40° C)
Control Box Required	See Note 3	See Note 3
Power Cable Length	50 ft. (15.2 m)	50 ft. (15.2 m)
Dry Weight	344 lb (156 kg)	TBD)
Max Height	33.5 in (85.09 cm)	TBD
Max Diameter	14.0 in (35.56 cm)	TBD

1. **Motor Rotation** – Let pump hang freely from a lifting device. Start and stop pump while observing movement (kick) of pump. If connected correctly the impeller will rotate clockwise (CW) as viewed from above. If pump rotates counterclockwise interchange any two phases from the power source.
2. **Mechanical Seal Oil** – Use ISO VG32 lubrication oil, Mobile DTE 24 turbine oil 90 or equivalent. Fill oil chamber 75% to 85% full (allow air space for expansion).
3. **Control Box** - For unattended operation, CB12 or CB14 Control Box (Table 3) is required. Control boxes will provide thermal overload protection.

ST4125G/ST6125G SUBMERSIBLE PUMP — DIMENSIONS

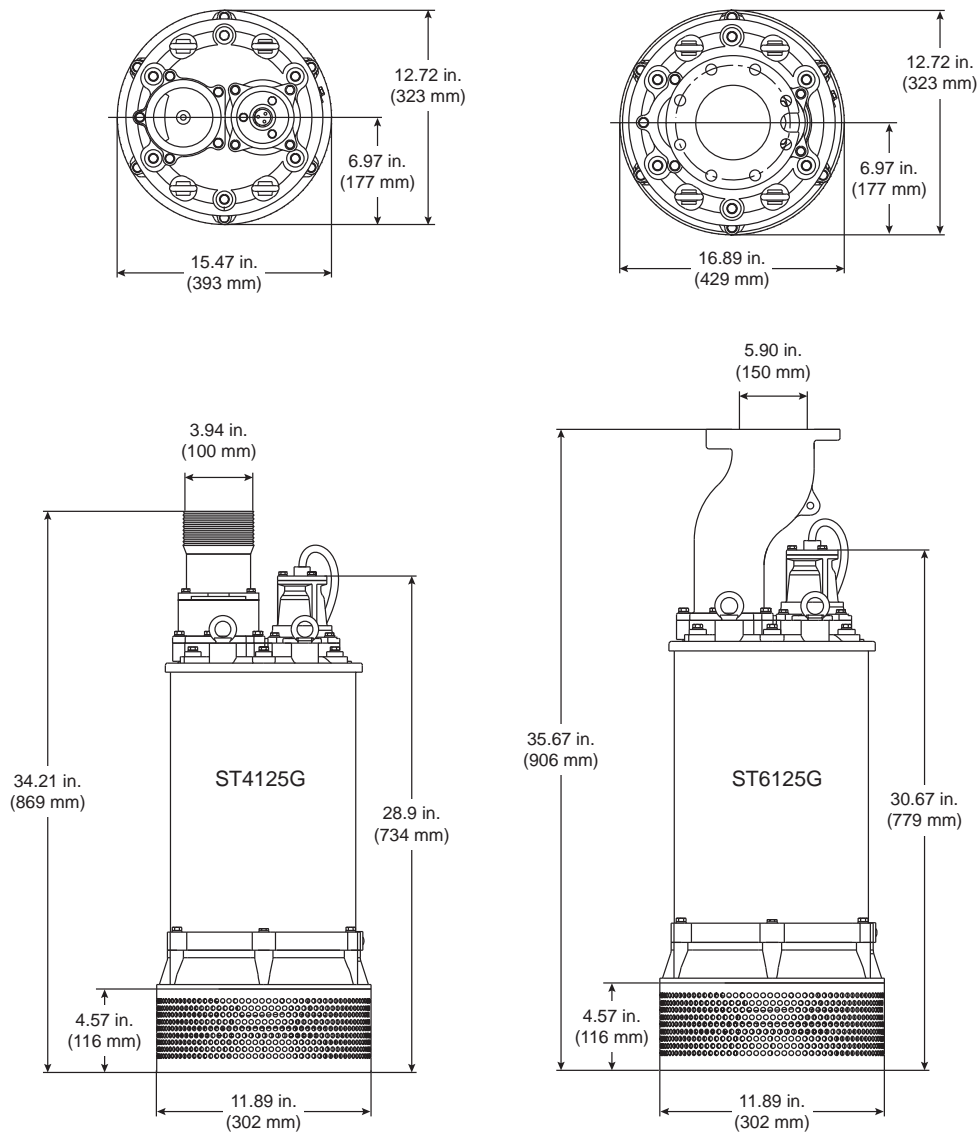

Figure 1. ST4125G/ST6125G Pump Dimensions

ST4125G/ST6125G — GENERAL INFORMATION

The Multiquip Model ST4125G and ST6125G submersible pumps are designed to pump water. These pumps work best when faced with high head applications where you need an appreciable flow.

Each pump has dual voltage capability, easily switched between 230 and 460 volts.

These pumps have a heavy-duty cast iron body that is very durable and able to withstand rough handling. The ST4125G comes with a 4-inch NPT threads for standard hose connections while the ST6125G is equipped with 6-inch flange fitting.

The mechanical seal of these pumps operates within an oil-filled chamber that provides positive lubrication. This helps prevent damage in the event the pump is run dry for short periods of time.

ST4125G/ST6125G — COMPONENTS

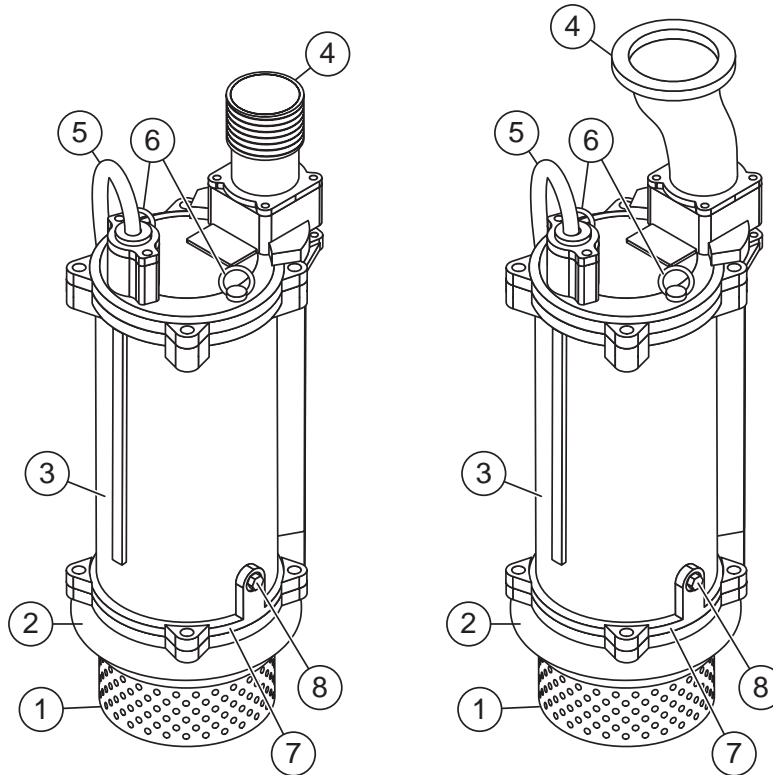

Figure 2. Submersible Pump Components

Figure 2 shows the location of the basic components, for the ST4125G and ST6125G submersible pumps. Listed below is a brief explanation of each component.

1. **Strainer Base** – This strainer base is made of stainless steel which is resistant to hardware corrosion. For dewatering purposes, always place the strainer base on a platform.
2. **Volute/Impeller** – Impellers are constructed of cast ductile iron to minimize wear and prolong service life.
3. **Electric Motor** – The ST4125G pump utilizes a 60 Hz, three-phase, 230/460 VAC, 10 HP electric motor and the ST6125G pump utilizes a 60 Hz, three-phase, 230/460 VAC, 15 HP electric motor. Consult with a licensed electrician before connecting motor to a power source. Observe all city and local safety codes.
4. **Discharge Port** – Connect a 4-inch hose (ST4125G) or 6-inch hose (ST6125G) to this port. Remember to adequately support the discharge hose to avoid stress on the pump.
5. **AC Power Cable** – These pumps are supplied with a 50 ft. (15.2 meters) AC power cable. Always check the cable for signs of wear. **NEVER** use a defective power cable. Replace the cable immediately if the cable is worn or defective.
6. **Eye Bolts** – Always lift the submersible pump by the eye bolts using a chain and lifting device capable of lifting about 400 lbs. **NEVER** lift the pump by its power cord! Lifting the pump by the power cord will cause undue stress on the cord and ultimately the cord will become dislodged from the pump.
7. **Mechanical Seal Oil** – This oil-filled seal provides lubrication when running the pump dry. **NEVER** run the pump dry! Running the pump dry will cause severe damage to the pump.
8. **Mechanical Seal Oil Plug** – Remove this plug to check and add ISO VG32 lubrication oil, Mobile DTE 24, turbine oil 90 or equivalent to the oil chamber. This oil protects the mechanical seal. Oil chamber should be full enough to cover seal spring.

FLOAT SWITCHES

Mechanical Float Switch

Mechanically activated float switches offer a reliable low current control for dewatering applications.

How It Works

The mechanical float switch control will turn **ON** (close) when the float tips 45° above -horizontal, indicating a high level, and turns **OFF** (opens) when the float switch drops 45° below horizontal. Reference Figure 4 and Figure 5. Maximum pumping range is 120 degrees. See Figure 3 below.

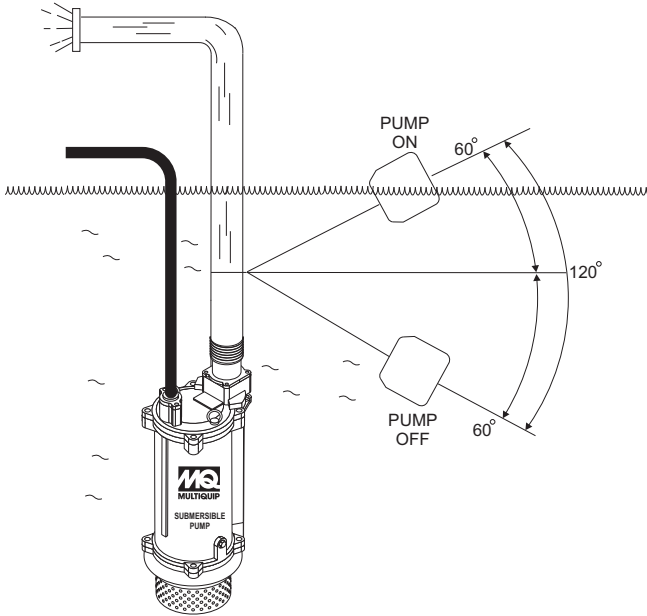

Figure 3. Pumping Range (Float Switch)

Pumping Range

The pumping range of the pump is determined by the float switch tether cord. Use Table 2 as guide line to determine your required pumping range. Pumping ranges are based on non-turbulent conditions. Range may vary due to water temperature and cord shape. Please note as the tether length increases, so does the variance of the pumping range.

Tether Length	2 in. 5.08 cm.	4 in. 10.16 cm.	6 in. 15.24 cm.	8 in. 20.32 cm.	10 in. 25.4 cm.	12 in. 30.48 cm.	14 in. 35.56 cm.	16 in. 40.46 cm.
Pumping Range	6 in. 15.24 cm.	10 in. 25.4 cm.	14 in. 35.56 cm.	18 in. 45.72 cm.	22 in. 55.88 cm.	27 in. 68.58 cm.	31 in. 78.74 cm.	35 in. 88.9 cm.

Design Features

Float switch housings are constructed of high-impact, corrosion resistant polypropylene with mechanically activated, snap action contacts.

- Suitable for most liquid environments.
- Hermetically sealed.
- Thick-walled non-corrosive PVC plastic enclosure.
- Pressure tested to 30 ft. (9 meters).
- Standard SJO, 16-gauge, 2 conductor cord (20 ft./6.09 m).

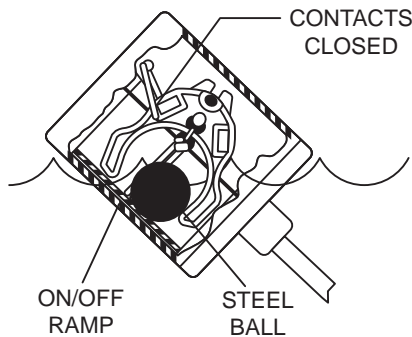

Figure 4. Float Switch (Closed)

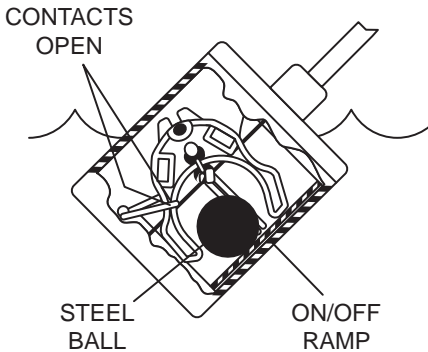

Figure 5. Float Switch (Open)

Float Switches

For unattended operation of the submersible pump two single float switches (Model SW-1WOPA) will be required. These float switches can be connected directly to a control box (bare wires) and will allow the pump to turn on and off depending on the length of the tether.

Mounting The Float Switches

1. Determine the required **cord tether length** as shown in Figure 3 and Table 2.
2. Place the cord into the clamp as shown in Figure 6.
3. Secure the clamp to the discharge hose as shown in Figure 6. **DO NOT** install cord under hose clamp.
4. Using a screwdriver, tighten the hose clamp. **DO NOT** over-tighten. Make sure the float cord is not allowed to touch the excess hose clamp band during operation.

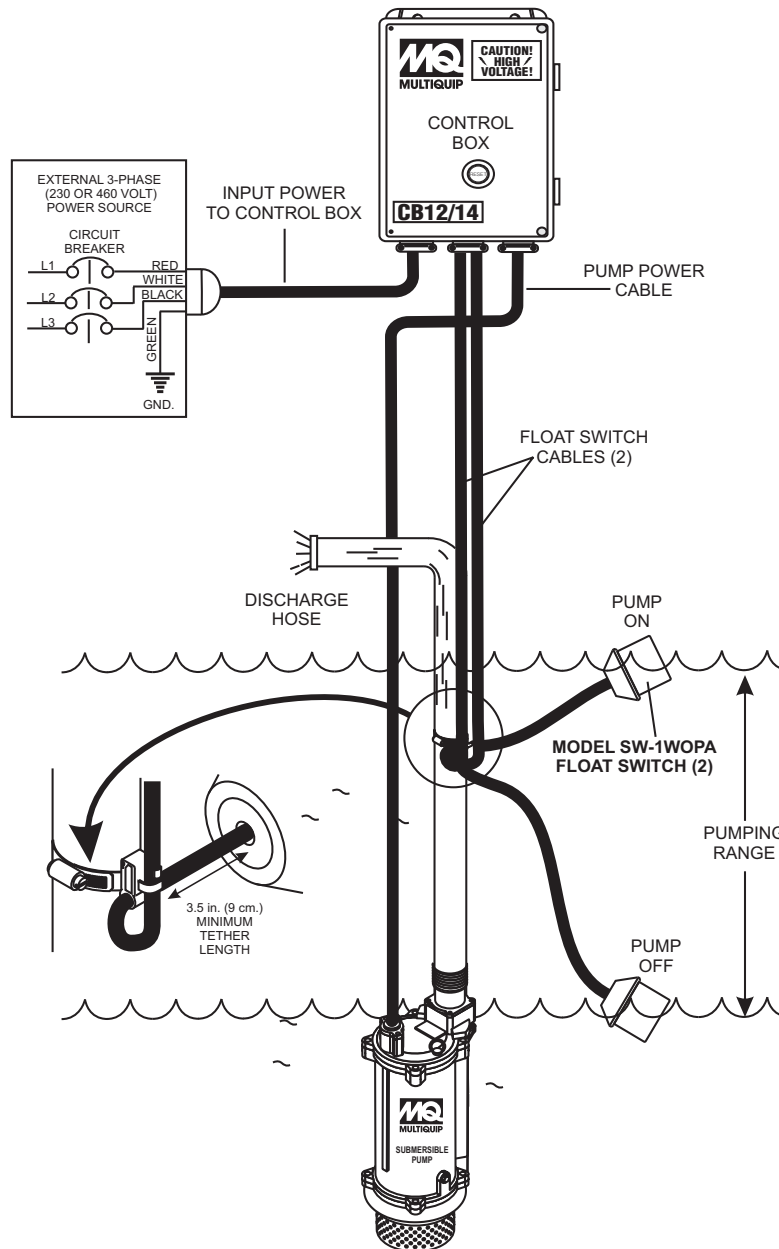

Figure 6. Float Switch Application

FLOAT SWITCHES

CB12/CB14 Control Boxes

For remote pumping applications, both submersible pumps, require a control box (Figure 7).

The CB12 control box requires 230VAC, 3-phase input voltage for normal operation, while the CB14 control box requires 460VAC, 3-phase input voltage. Reference Table 3 for the desired heater. The heater size is determined by the the full load amps the pump will draw.

These water-resistant control boxes provide electronic overload protection a watertight enclosure and glands to prevent water from leaking into the box, and a float switch interface.

Each control box will require the use of *two* SW-1WOPA float switches, no plug, bare wires for direct connection to the control box. Reference Figure 21 for a schematic representation of the control box.

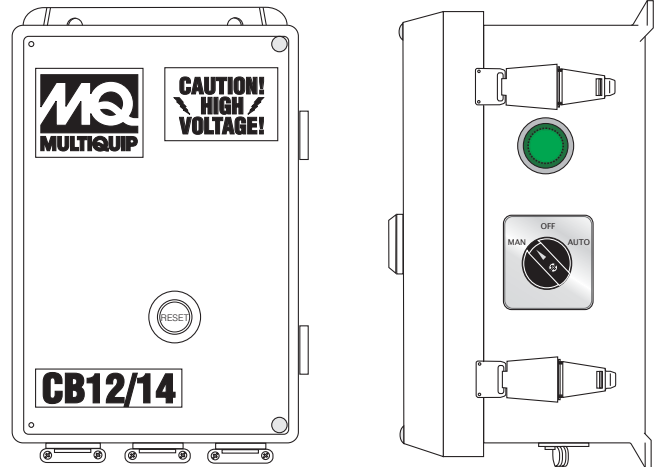

Figure 7. Electrical Control Box (Model CB12/14)

NOTICE

Contact Multiquip sales department to order control boxes as listed in Table 3.

Table 3. Control Box Specifications

Control Box Model No.	Used With Pump Model	VoltageType	Heater Size	Full Load Amps	UL/CSA Listed	Thermal Overload Protection	Float Switch Capability
CB12	ST-4125G	230 VAC Three-Phase	K67	27	YES	YES	YES
CB12	ST-6125G	230 VAC Three-Phase	K73	39	YES	YES	YES
CB14	ST-4125G	460 VAC Three-Phase	K56	14	YES	YES	YES
CB14	ST-6125G	460 VAC Three-Phase	K62	19.7	YES	YES	YES

CONTROL BOX INSTALLATION

Control Box Installation

The following procedure outlines the steps for connecting the pump to a control box.

! DANGER



The ST4125G and ST6125G submersible pumps are designed to work with a control box. This control box contains the necessary electronics (float switch connections) to operate the pump. Remember this control box contains hazardous voltages. Disconnect all sources of power before installing or servicing. There exists the possibility of electrocution, electric shock or burn, which can cause severe bodily harm or even **death!**

! DANGER



When installing the control box, the possibility exists of electrical shock, electrocution and possibly death! **NEVER** have untrained personnel perform the installation. **ALWAYS** have qualified service personnel (licensed electrician) perform the installation.

! WARNING



Explosion or Fire Hazard exists if this pump is used with flammable liquids. **DO NOT** use this pump with **flammable liquids**. **DO NOT** install this pump in hazardous locations as defined by the National Electrical Code, ANSI/NFPA 70.

CONTROL BOX MOUNTING

Mount the control box in an upright vertical position. Make sure the control box is securely fastened to a flat surface, that is free of dust, dirt, moisture or any elements that may contaminate or erode the electronic components of the control box.

3-Phase Power Installation (Input)

The ST-4125G/ST6125G submersible pumps require 230 or 460V 3-phase power for normal operation. Each pump is shipped from the factory in the 230 VAC configuration. To change the voltage setting from 230 VAC to 460 VAC refer to the 230/460 VAC voltage selection section (Figure 8).

If you cannot determine what your pump's power requirements are, look at the vendor supplied identification name tag attached to the pump or please contact Multiquip's Service/Technical Assistance department.

! CAUTION

Applying incorrect power (voltage phasing) to the submersible pump can cause severe damage to the pump. Please make sure that the correct voltage and phase are applied to the pump at all times.

Power Cord Requirements

When routing the 230/460 VAC, 60 Hz., 3-phase power via a power cord to the control box, **ALWAYS** use the correct wire size. Please refer to Table 4 to determine the correct wire size. Incorrect wire size can adversely affect the performance of the pump and may ultimately burn out the pump motor.

Table 4. Power Cord Length and Wire Size

AMPS	10 FT. (3.0 m)	20 FT. (6.0 m)	30 FT. (9.1 m)	50 FT. (15.2 m)
15	12 AWG	10 AWG	8 AWG	6 AWG
20	10 AWG	8 AWG	6 AWG	4 AWG
25	10 AWG	6 AWG	6 AWG	4 AWG
30	10 AWG	6 AWG	4 AWG	2 AWG
40	8 AWG	6 AWG	4 AWG	2 AWG

Connecting SW-1WOPA Float Switches to Control Box

1. Remove the float switch input connector housing, then route the float switch wires through the cable gland on the control box. Attach the wires of the float switch to the terminal block as indicated by Table 5 and Figure 9.

Table 5. Dual Float switch Connections

Float Switch	Terminal Block No.	Wire Color
Start	TB1-A1	Black
	TB1-A2	White
Stop	TB1-A3	Black
	TB1-A4	White

2. Tighten the connector housing to ensure a tight fit between the cord and the connector body. This will prevent the cable from pulling out of the terminal block and also prevent moisture from entering the control box.
3. Determine the tether length of the float switch wires then secure float switch wires to pump discharge hose. See Figure 3 and Table 2 to determine the pumping range.

230/460 VAC VOLTAGE SELECTION

230/460 VAC Voltage Selection

The ST4125G/ST6125G submersible pumps are factory set at 230 VAC. To change the voltage from 230 VAC to 460 VAC, reference Figure 8:

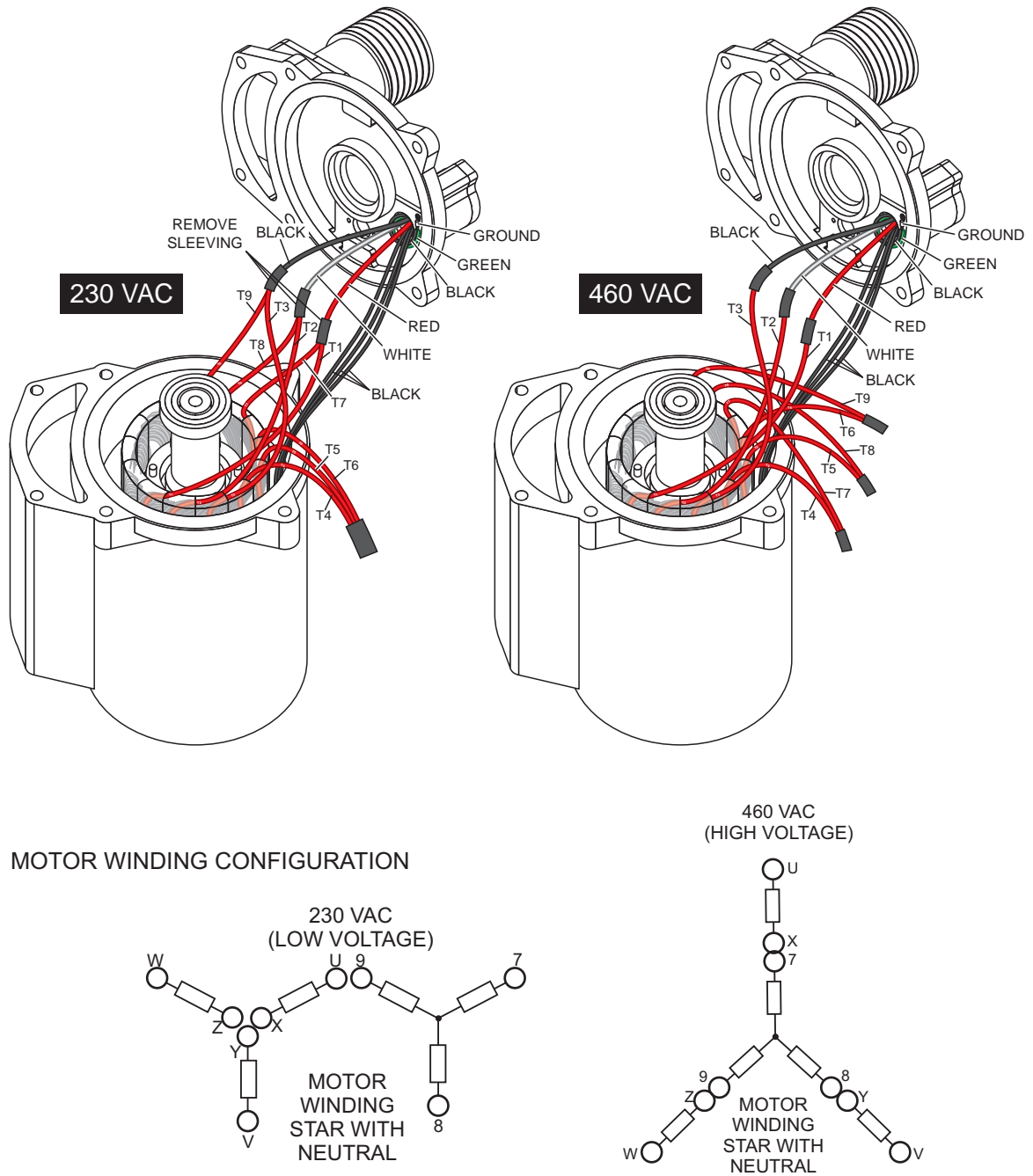

Figure 8. 230/460 VAC Electric Motor Windings

CB12/CB14 CONTROL BOX POWER CONNECTIONS

3-Phase Power Installation (Input to Control Box)

1. The 3-phase input power cord should have four wires. Each wire is color coded. The colors are **RED**, **WHITE**, **BLACK** and **GREEN**.
2. Remove the 3-phase AC input connector housing from the control box, then route the three phase input power cable through the cable gland on the control box. Attach the wires to the AC terminal block inside the control box as indicated by Table 6 and Figure 9.

Table 6. 3Ø-230/460 VAC Input Power Connections	
Wire Color	Input Power Terminal Block
RED	L1
WHITE	L2
BLACK	L3
GREEN	GROUND

3. Tighten the connector housing to ensure a tight fit between the power cord and the connector body. This will prevent the cable from pulling out of the terminal block and also prevent moisture from entering the control box.
4. Connect the other end of the 3-phase input power cord to the voltage source. Remember to provide a means of disconnecting the power from the control box (circuit breaker or quick disconnect switch). Also make sure to provide a good earth ground to the control box.

NOTICE

It is recommended that the power being supplied to the control box **ALWAYS** be connected to a circuit breaker or a quick disconnect switch. This safety feature allows for quick removal of power from the control box in the event of an emergency.

3-Phase Power Installation (Output To Pump)

1. The 3-phase output power cord should have four wires. Each wire is color coded. The colors are **RED**, **WHITE**, **BLACK** and **GREEN**.
2. Remove the 3-phase AC output power connector housing on the control box, then route the output power cable through the cable gland on the control box. Attach the wires to the AC terminals on the overload relay module as indicated by Table 7 and Figure 9.

Table 7. 3Ø-230/460 VAC Output Power Connections	
Wire Color	Output Power Overload Relay
RED	T1
WHITE	T2
BLACK	T3
GREEN	GROUND

CB12/CB14 CONTROL BOX WIRING LAYOUT

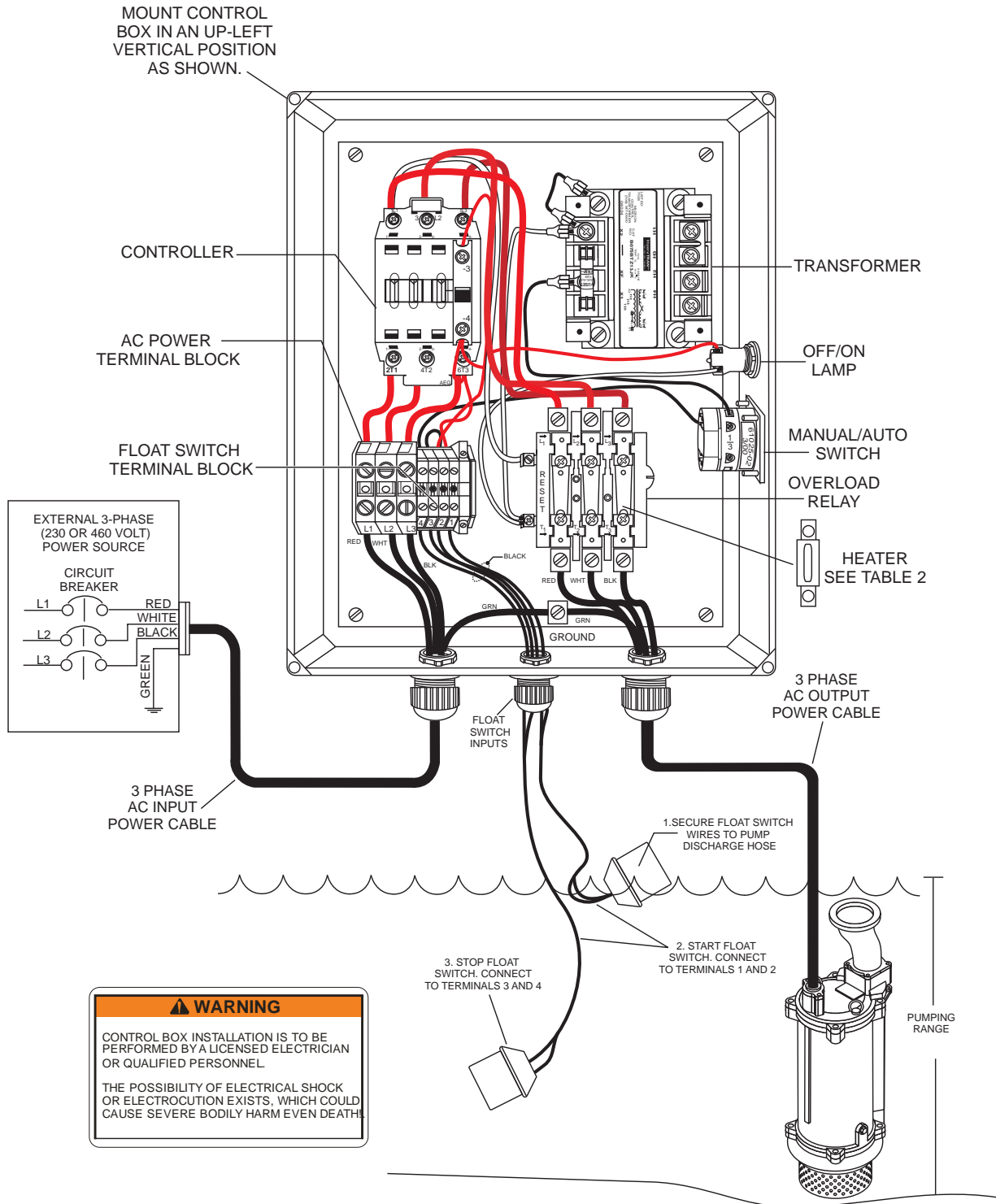

Figure 9. Three Phase Control Box/Pump System Diagram

Pump Placement

1. Attach a suitable lifting chain to the eye bolts (Figure 10) on the pump. Use a crane, or similar lifting device and lower the pump into place. For applications where there is an excessive amount of mud, grit or silt, the use of a support platform is desirable.

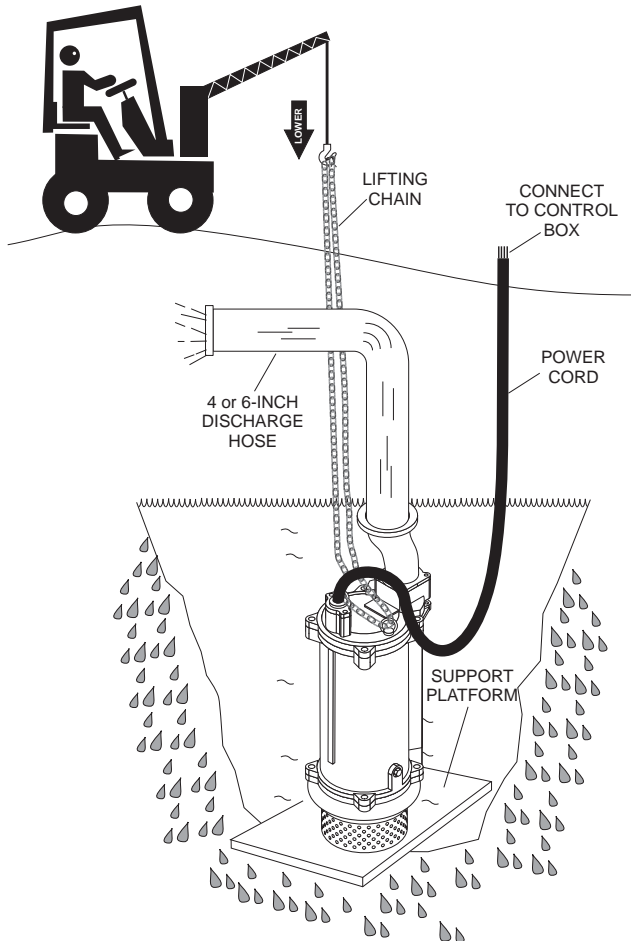
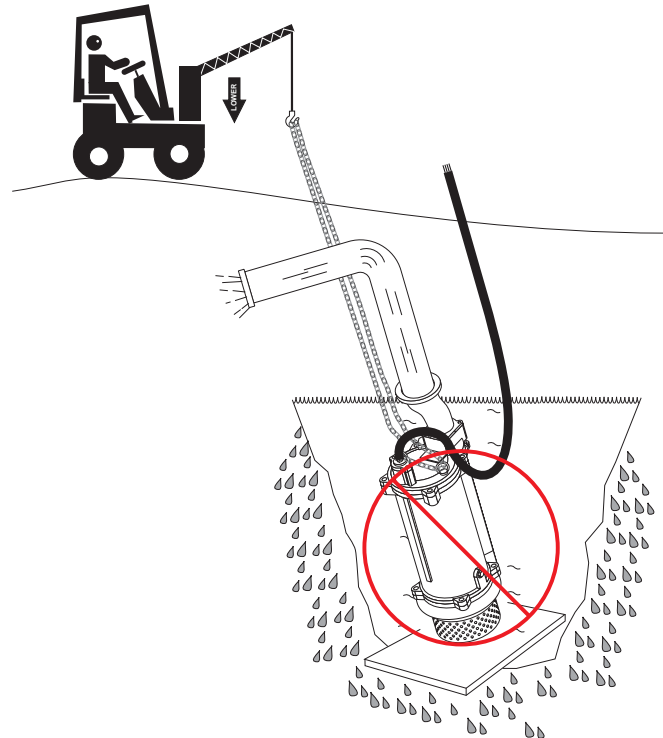

Figure 10. Placing the Submersible Pump (Correct Upright Position)

2. Make sure the pump is always placed in an upright position, not tilted (Figure 11). Never position the pump directly on a soft, loose bottom. To attain maximum pumping capacity and prevent excessive wear, position the pump so it will not burrow itself into sand or clay.



**Figure 11. Tilted Position (Incorrect)
Control Box Operation (Manual Mode)**

1. From the voltage source, set the circuit breaker or quick disconnect switch to the **ON** position.
2. For manual operation of the pump, place the 3-position operation switch (Figure 12) on the control box in the **MANUAL** position.



**Figure 12. Manual-Off-Auto SW.
(Manual Position)**

3. Verify that the **ON** indicator (Figure 13) on the control box is **LIT**. This means that power is being supplied to the control box.



Figure 13. Control Box Power ON Indicator

4. In the manual mode the pump will run continuously. Pay close attention when running the pump in this mode. **DAMAGE** to the pump may occur if pump is not fully immersed in water.

Control Box Operation (Auto Mode)

1. To operate the pump automatically (float switches), place the 3-position operation switch in the **AUTO** position (Figure 14).



**Figure 14. Manual-Off-Auto SW.
(Auto Position)**

2. In the **AUTO** mode the pump will run as long as there is a sufficient amount of water. This amount of water is determined by the setting of the float switches. The **stop float** switch contacts will open when the water level is low and power will be removed from the pump's electric motor.

Once the water level has risen back to the appropriate level the **start float** switch contacts will close and power will be restored to the pump's motor.

Reset Button

1. When the electronic overload module detects an overload condition, the pump will shut down. Check the pump and correct the cause of their overload.
2. Let the pump cool down, then press the **RESET** button (see Figure 15) on the front of the control box to restore power.



Figure 15. RESET Button

Shut-Down

1. Place the 3-position operation switch on the control box to the **OFF** position (Figure 16).

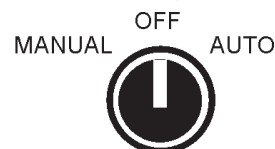

**Figure 16. Manual-Off-Auto SW.
(OFF Position)**

2. Verify that the control box power **ON** light is **OFF**.
3. Turn the circuit breaker or quick disconnect switch to the **OFF** position.
4. Using a suitable lifting device, lift the pump up from its current position and place on a secure flat surface.
5. Remove the discharge hose from the discharge port on the pump.
6. Remove all power cables and float switches from the control box. Place cables and float switches in a suitable container where they will not get damaged.
7. If the pump was used to pump mud, grit or silt, flush vigorously with clean water.
8. Wipe off any mud or debris that might have attached itself to the pump.
9. Store pump in a clean dry place away from dirt and debris.

Lubrication

To check the lubrication oil level of the mechanical seal perform the following:

Checking Lubrication Oil Level

1. Lay the pump (Figure 17) on its side with the oil plug facing upwards.
2. Remove oil fill plug.
3. Visually inspect oil plug hole to verify that oil chamber is full enough to cover seal spring.
4. When reinstalling oil fill plug, apply teflon tape to prevent leaking.

WARNING



When removing oil fill plug, please note that pressure may have built up in the oil chamber. **DO NOT** fully remove plug until pressure has been relieved. Turn oil fill plug slowly to relieve pressure.

Changing Lubrication Oil

1. If lubrication oil level is low, block the oil fill opening with a finger and roll pump to one side to drain oil into a small container.
2. Use a funnel (Figure 17) and fill oil chamber with ISO VG32 lubrication oil or equivalent. Oil chamber capacity is 74.4 oz. (2.2 liters). Fill to 75-80% capacity to allow for expansion. Replace lubrication oil once a year or 3,000 hours.

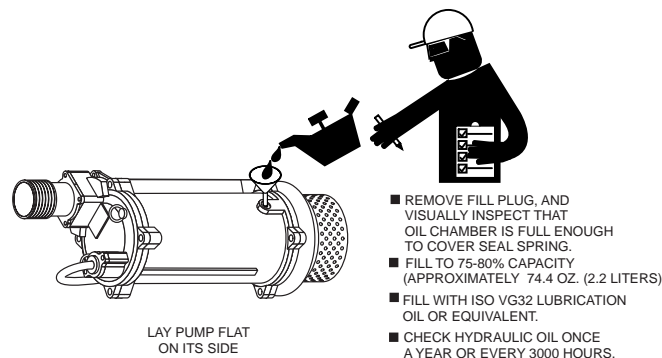

Figure 17. Adding Lubrication Oil

Inspecting Lubrication Oil (Mechanical Seal)

1. Block the oil fill opening with a finger and roll pump to one side to drain (Figure 18) oil into a small transparent container.
2. If oil is cloudy (milky) or has water in it, indicates that mechanical seal is defective or worn. Replace **mechanical seal**.

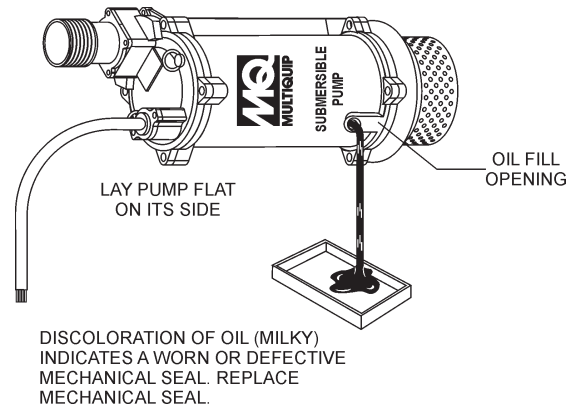

Figure 18. Lubrication Oil Inspection

NOTICE

When replacing the oil in the oil chamber, shaft seal **MUST** be changed at the same time.

Impeller Removal

Refer to the the following procedure and Figure 19 for the removal of the impeller.

1. Remove oil plug (item 193) and o-ring (item 194). Drain oil from oil chamber as referenced in Figure 18.
2. Remove suction strainer/ring stand (item 84A).
3. Remove the six suction cover bolts and washers (items 188A/188B) that secure the suction cover (item 189) to the pump housing (item 50). Remove suction cover (item 189).
4. Remove impeller cap nut (item 188) and washer (item 66) from motor shaft.
5. Remove impeller (item 49), gap washer (item 49A) and impeller key (item 9A) from motor shaft.
6. Reassemble in reverse order.

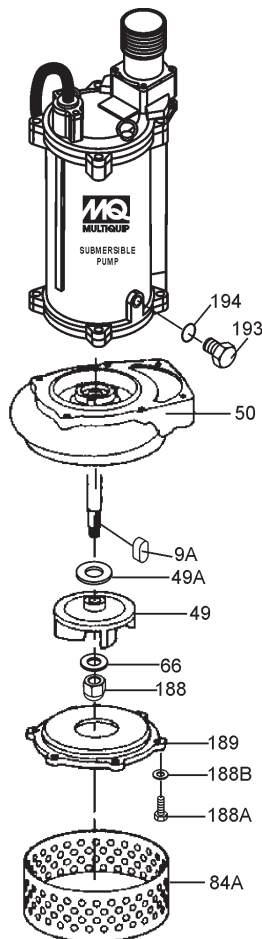

Figure 19. Impeller Removal

NOTICE

Clearance between impeller and wear plate should be between .011~.019 in. (0.3~0.5 mm). If impeller is defective or badly worn, replace immediately.

Long Term Storage

1. Area must be free from excessive humidity, corrosive gases, vapors or vibrations which might damage the pump.
2. Store pump in a vertical position on a pallet or stand.
3. Coil up the cable, and seal the open end (control box wires) with waterproof tape or a cable cap. This will prevent moisture from penetrating into the motor which could cause severe damage to the windings.
4. Give all unpainted surfaces a light coat of oil or grease to prevent corrosion.
5. If new pumps are stored for more than two months, turn the impeller by hand every two months to prevent the mechanical seal faces from seizing up. Failure to do this may result in seal damage when the pump is started.

Water Tank Storage

1. If an installed pump (immersed in water) has not been in operation for a long period of time, check the insulation resistance and run the pump for 30 minutes every month.

If the pump cannot be run due to lack of water in the tank inspect the pump and turn the impeller by hand each month and prior to putting the pump back into service. If insulation drops below 10 megohms, contact an authorized Multiquip service center.

Electrical Insulation Testing

Why perform electrical insulation testing?

Electrical insulation starts to age as soon as it is made. Harsh environments, especially those with extreme temperature changes and/or chemical contamination, cause further deterioration of the insulation (power cord).

As a result, personnel safety (electrocution/shock) and power reliability can suffer resulting in higher operating cost and maintenance.

What is Insulation Resistance Testing

Insulation resistance testing applies a regulated stabilized high voltage (Figure 20), typically 500 VDC or greater across a dielectric (power cord). Measuring the amount of **leakage current** flowing through the dielectric will yield a resistive measurement in megohms.

Insulating Material Testing

To verify the integrity of the pump's insulating material (power cable) it will be necessary to perform an electrical insulation test. Any electrical insulation must have the opposite characteristic as the conductor: it should resist the flow of current, keeping it within the conductor.

To measure the IR (current x resistance), the use of an IR tester must be employed. This IR tester is a portable device that is a resistance meter (ohmmeter) with a built in DC generator that develops a high DC voltage.

The high DC voltage from the IR tester is usually 500 VDC or more. This voltage, when applied causes a small current to flow through and over the insulation's surfaces. The tester provides a direct reading of IR in megohms.

A high resistance reading would indicate a "**good**" insulation, meaning very little current is escaping through the insulation. While a relatively low resistance reading would indicate a **poor** insulation, meaning a significant amount of current may be leaking through and along the insulation.

NOTICE

Insulation resistance is moisture and temperature sensitive. When temperature increases, insulation resistance decreases, and vice versa.

When performing this test measurement, perform the test using the same test parameters as used in the initial testing. Contact an authorized Multiquip service center if the measured cable insulation is **10 megohms or less**.

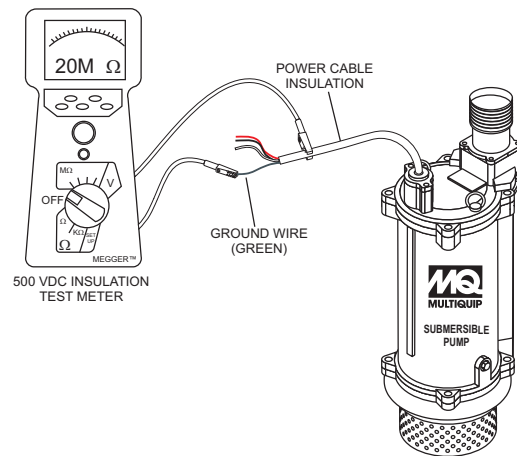

Figure 20. Insulation Tester Application

⚠ DANGER



Read and follow the manufacturer's user's manual prior to operating insulation tester (megaohm meter). This meter generates a test voltage of 500 volts or greater. Only qualified and trained personnel should use this equipment. The possibility exists of severe **electrical shock, electrocution even death**, when using insulation tester.

Table 8. Pump Troubleshooting

SYMPTOM	POSSIBLE PROBLEM	SOLUTION
Pump Fails To Start	Incorrect voltage/amps?	Check that the proper voltage, 230 or 460 VAC, 60 Hz, 3-phase is being supplied to the pump. Also check that there is an adequate amount of current (amps) to run the pump. Check power source circuit breaker.
	Check electrical connections?	If using float switches check wiring, inspect power cord.
	Blown power fuse or tripped circuit breaker?	Replace fuse check circuit breaker, check cause of blown fuse or tripped breaker.
	Impeller locked?	Disconnect power cord and check for clogging. Unclog pump. Check overload protection device.
	Wet motor windings?	Use multimeter to check motor insulation. Insulation resistance must be approximately 15 megaohms. If resistance is low, disassemble pump motor and bake windings to dry them.
	Defective motor and pump bearings?	Check for excessive bearing wear, if worn replace bearings. Replace motor if defective.
Pump Fails to Deliver Full Output	Twisted or restricted discharge hose?	Lay hose flat un-kinked. Remove clog from hose line.
	Clogged pump strainer?	Clean strainer.
	Low voltage?	Use a voltmeter to check voltage while pump is energized. Voltage must be within $\pm 10\%$. Check power source (no load and load). If an extension cord is used, make sure it has adequate current-carrying capacity for the required length. See Table 4.
	Impeller worn?	Replace impeller.
Water in Mechanical Seal Oil	Defective mechanical seal?	Replace mechanical seal.
	Loose Oil Fill Plug?	Tighten securely. Apply teflon tape.

CB12/CB14 CONTROL BOX WIRING DIAGRAM

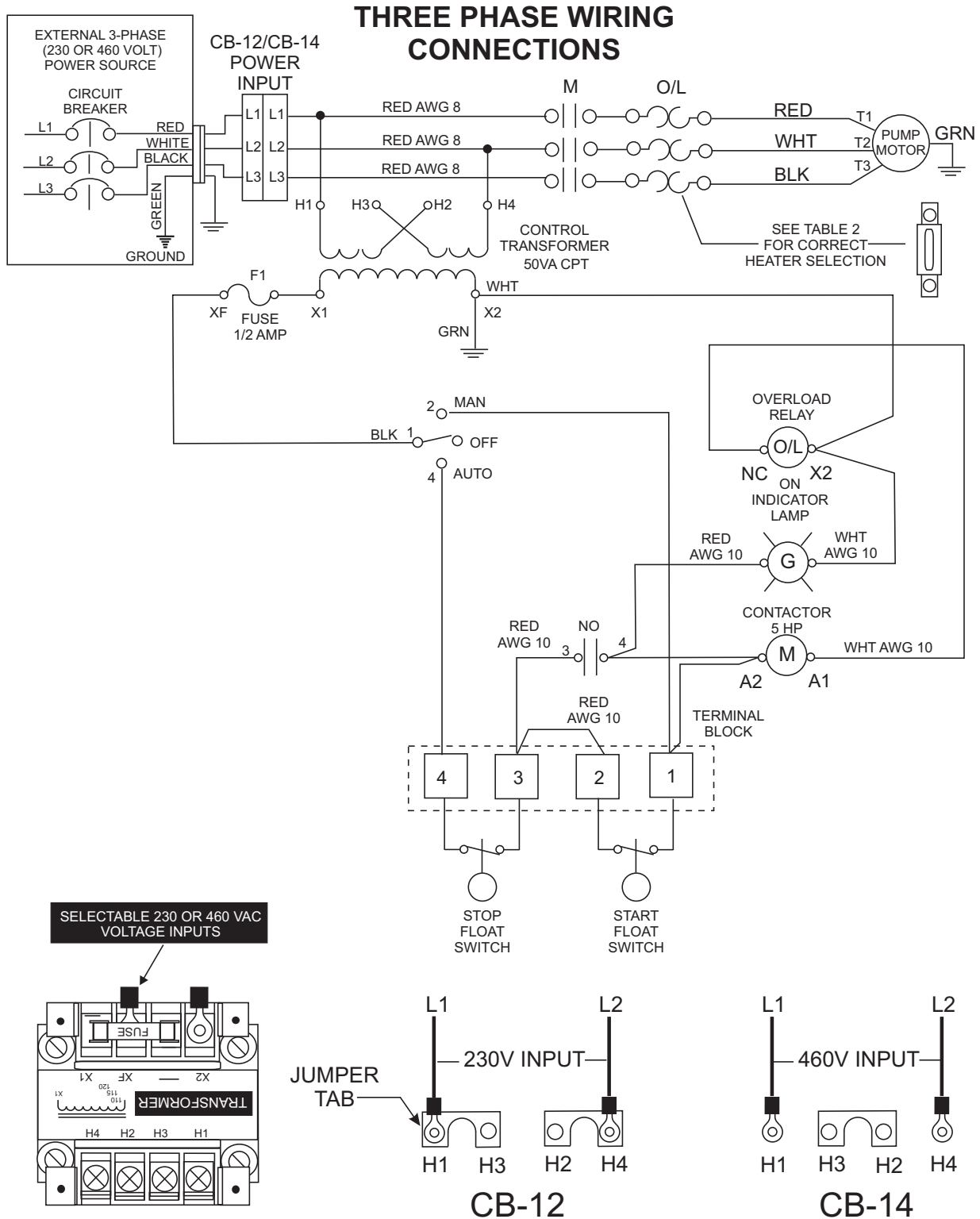

Figure 21. CB12/CB14 Control Box Wiring Diagram

OPERATION AND PARTS MANUAL

HERE'S HOW TO GET HELP

PLEASE HAVE THE MODEL AND SERIAL
NUMBER ON-HAND WHEN CALLING

UNITED STATES

Multiquip Corporate Office

18910 Wilmington Ave. Tel. (800) 421-1244
Carson, CA 90746 Fax (800) 537-3927
Contact: mq@multiquip.com

Service Department

800-421-1244 Fax: 310-537-4259
310-537-3700

Technical Assistance

800-478-1244 Fax: 310-943-2238

MQ Parts Department

800-427-1244 Fax: 800-672-7877
310-537-3700 Fax: 310-637-3284

Warranty Department

800-421-1244 Fax: 310-537-1173
310-537-3700

MEXICO

MQ Cipsa

Carr. Fed. Mexico-Puebla KM 126.5 Tel: (52) 222-225-9900
Momoxpan, Cholula, Puebla 72760 Mexico Fax: (52) 222-285-0420
Contact: pmastretta@cipsa.com.mx

CANADA

Multiquip

4110 Industriel Boul. Tel: (450) 625-2244
Laval, Quebec, Canada H7L 6V3 Tel: (877) 963-4411
Contact: jmartin@multiquip.com Fax: (450) 625-8664

UNITED KINGDOM

Multiquip (UK) Limited Head Office

Unit 2, Northpoint Industrial Estate, Tel: 0161 339 2223
Globe Lane, Fax: 0161 339 3226
Dukinfield, Cheshire SK16 4UJ
Contact: sales@multiquip.co.uk

© COPYRIGHT 2010, MULTIQUIP INC.

Multiquip Inc and the MQ logo are registered trademarks of Multiquip Inc. and may not be used, reproduced, or altered without written permission. All other trademarks are the property of their respective owners and used with permission.

This manual MUST accompany the equipment at all times. This manual is considered a permanent part of the equipment and should remain with the unit if resold.

The information and specifications included in this publication were in effect at the time of approval for printing. Illustrations, descriptions, references and technical data contained in this manual are for guidance only and may not be considered as binding. Multiquip Inc. reserves the right to discontinue or change specifications, design or the information published in this publication at any time without notice and without incurring any obligations.

Your Local Dealer is:

