

\$1.00

# OWNER'S GUIDE

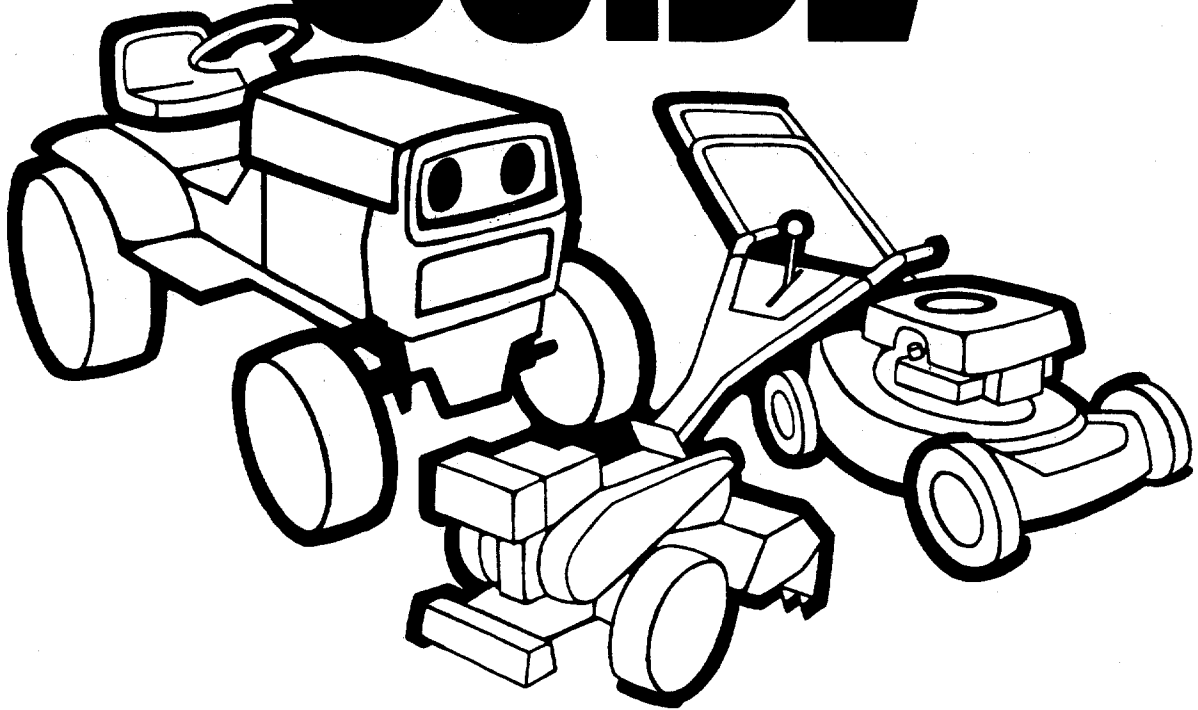

**CHAIN DRIVE  
TILLER**

**Model Number  
217-310-000**

**IMPORTANT: Read Safety Rules and Instructions Carefully**

# INDEX

Safe Operation Practices .....	3
Assembly Instructions .....	4
Operation .....	10
How to Use Your Tiller .....	11
Adjustments .....	12
Lubrication .....	13
Maintenance .....	13
Off-Season Storage .....	14
Trouble Shooting Chart .....	15
Repair Parts .....	16-19
Parts Information .....	Back Cover

Dear Customer,

*So often throughout the year we are all in a rush to meet our daily obligations.*

*However, we at MTD Products Inc are taking a quick moment out to say . . .*

**“Thank you for your business.”**

*Sincerely,*  
MTD PRODUCTS INC



**INSTRUCTIONS GIVEN WITH THIS SYMBOL ARE FOR PERSONAL SAFETY. BE SURE TO FOLLOW THEM.**

## LIMITED WARRANTY

For one year from the date of original retail purchase, MTD PRODUCTS INC will either repair or replace, at its option, free of charge, F.O.B. factory or authorized service firm, any part or parts found to be defective in material or workmanship. Transportation charges for the movement of any power equipment unit or attachment are the responsibility of the purchaser. Transportation charges for any parts submitted for replacement under this warranty must be paid by the purchaser unless such return is requested by MTD PRODUCTS INC.

This warranty will not apply to any part which has become inoperative due to misuse, excessive use, accident, neglect, improper maintenance, alterations, or unless the unit has been operated and maintained in accordance with the instructions furnished. This warranty does not apply to the engine, motor, battery, battery charger or component parts thereof. Please refer to the applicable manufacturer's warranty on these items.

This warranty will not apply where the unit has been used commercially.

Warranty service is available through your local authorized service dealer or distributor. If you do not know the dealer or distributor in your area, please write to the Customer Service Department of MTD.

The return of a complete unit will not be accepted by the factory unless prior written permission has been extended by MTD.

This warranty gives you specific legal rights. You may also have other rights which vary from state to state.

**WARNING:** This unit is equipped with an internal combustion engine and should not be used on or near any unimproved forest-covered, brush-covered or grass-covered land unless the engine's exhaust system is equipped with a spark arrester meeting applicable local or state laws (if any). If a spark arrester is used, it should be maintained in effective working order by the operator.

In the State of California the above is required by law (Section 4442 of the California Public Resources Code). Other states may have similar laws. Federal laws apply on federal lands. A spark arrester muffler is available at your nearest engine authorized service center.



To reduce the potential for any injury, comply with the following safety instructions. Failure to comply with the instructions may result in personal injury.

## SAFE OPERATION PRACTICES FOR TILLERS

1. It is suggested that this manual be read in its entirety before attempting to assemble or operate this unit. Keep this manual in a safe place for future and regular reference and for ordering replacement parts.
2. Your tiller is a precision piece of power equipment, not a plaything. Therefore, exercise extreme caution at all times.
3. Read this Owner's Manual carefully. Be thoroughly familiar with the controls and the proper use of the equipment.
4. Never allow children to operate a power tiller. Only persons well acquainted with these rules of safe operation should be allowed to use your tiller.
5. No one should operate this unit while intoxicated or while taking medication that impairs the senses or reactions.
6. Keep the area of operation clear of all persons, particularly small children and pets.
7. Do not operate equipment when barefoot or wearing open sandals. Always wear substantial footwear.
8. Do not wear loose fitting clothing that could get caught on the tiller.
9. Do not start the engine unless the shift lever is in the neutral (N) position.
10. Do not stand in front of the tiller while starting the engine.
11. Do not place feet and hands on or near the tines when starting the engine or while the engine is running.
12. Never attempt to make a wheel or depth bar adjustment while the engine is running.
13. Do not leave the tiller unattended with the engine running.
14. Do not walk in front of the tiller while the engine is running.
15. Check the fuel before starting the engine. Gasoline is an extremely flammable fuel. Do not fill gasoline tank indoors, while the engine is running, or while the engine is still hot. Replace gasoline cap securely, and wipe off any spilled gasoline before starting the engine as it may cause a fire or explosion.
16. Do not run the engine while indoors. Exhaust gases are deadly poisonous.
17. Be careful not to touch the muffler after the engine has been running. It is hot.
18. Do not change the engine governor settings or overspeed the engine. Excessive engine speeds are dangerous.
19. Before any maintenance work is performed or adjustments are made, remove the spark plug wire and ground it on the engine block for added safety.
20. Use caution when tilling near buildings and fences. Rotating tines can cause damage or injury.
21. Before attempting to remove rocks, bricks and other objects from tines, stop the engine and be sure the tines have stopped completely. Disconnect the spark plug wire and ground to prevent accidental starting.
22. Check the tine and engine mounting bolts at frequent intervals for proper tightness.
23. Keep all nuts, bolts and screws tight to be sure the equipment is in safe working condition.
24. Never store the equipment with gasoline in the tank inside of a building where fumes may reach an open flame or spark. Allow the engine to cool before storing in any enclosure.

**NOTE**

Reference to left or right side of the tiller is determined from behind the unit in the operating position.

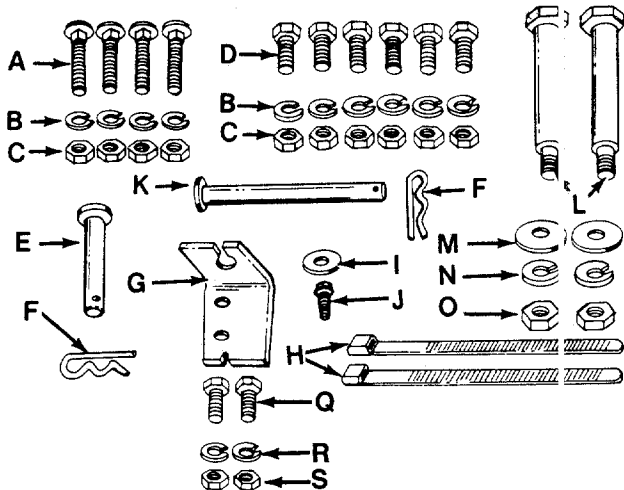

FIGURE 1.

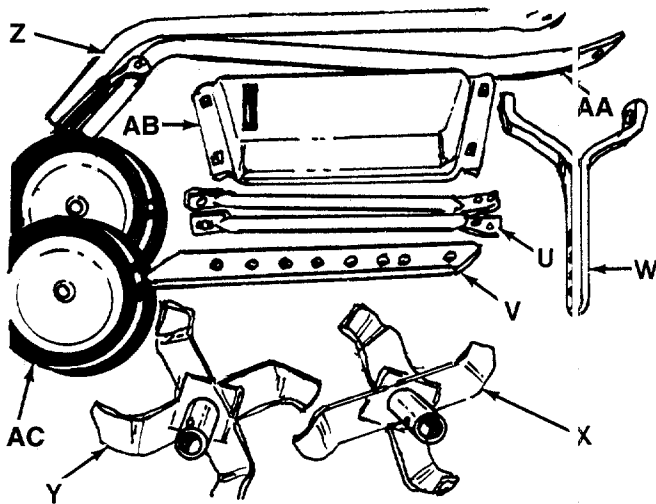

FIGURE 2.

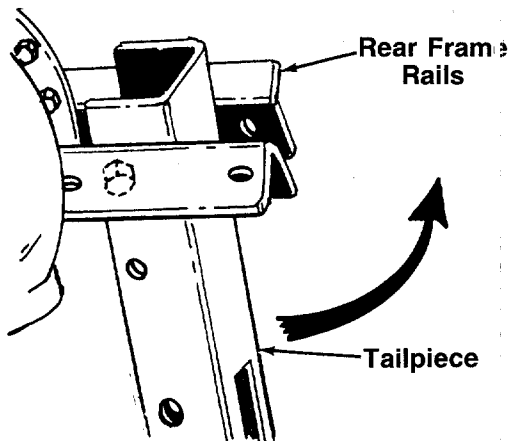

FIGURE 3.

# ASSEMBLY INSTRUCTIONS

**NOTE**

This unit is shipped WITHOUT GASOLINE or OIL. After assembly, see separate engine manual for proper fuel and engine oil recommendations.

**Tools Required:**

- (2) 1/2" Wrenches
- (2) 7/16" Wrenches
- (1) 3/4" Wrench
- (1) Adjustable Wrench
- (1) Phillips Screwdriver

**Contents of Hardware Pack: (See Figure 1)**

- A (4) Carriage Bolts 5/16-18 x 1 3/4" Long
- B (10) Lock Washers 5/16" I.D.
- C (10) Hex Nuts 5/16-18 Thread
- D (6) Hex Bolts 5/16-18 x 3/4" Long
- E (1) Clevis Pin 1/2" x 2 1/2" Long
- F (2) Hairpin Cotters
- G (1) Clutch Cable Support Bracket
- H (2) Cable Ties
- I (1) Flat Washer
- J (1) Hex Washer Head Self-Tapping Screw 1/2" Long
- K (1) Clevis Pin 3/8" x 2 1/2" Long
- L (2) Shoulder Bolts (Axles)
- M (2) Belleville Washers
- N (2) Lock Washers 1/2" I.D.
- O (2) Hex Nuts 1/2-20 Thread
- P (2) Grips (Not Shown)
- Q (2) Hex Bolt 1/4-20 x 5/8" Long
- R (2) Lock Washers 1/4" I.D.
- S (2) Hex Nuts 1/4-20 Thread
- T (1) Phillips Head Self-Tapping Screw 1/2" Long (Not Shown)

**Loose Parts in Carton: (See Figure 2)**

- U (2) Handle Braces (Right & Left Hand)
- V (1) Depth Bar
- W (1) Wheel Yoke Assembly
- X (1) Right Hand Tine Assembly
- Y (1) Left Hand Tine Assembly
- Z (1) Right Hand Handle
- AA (1) Left Hand Handle
- AB (1) Handle Panel
- AC (2) Wheels
- AD (1) Tine Shield Extension (Not Shown)

1. Remove the tiller, all loose parts and literature from the carton before discarding carton.
2. Extend the throttle control and place on the floor. Be careful not to bend or kink control wire.

3. The tailpiece is partially assembled. Pivot the tailpiece upward until the holes line up with the rear frame rails. See figure 3.

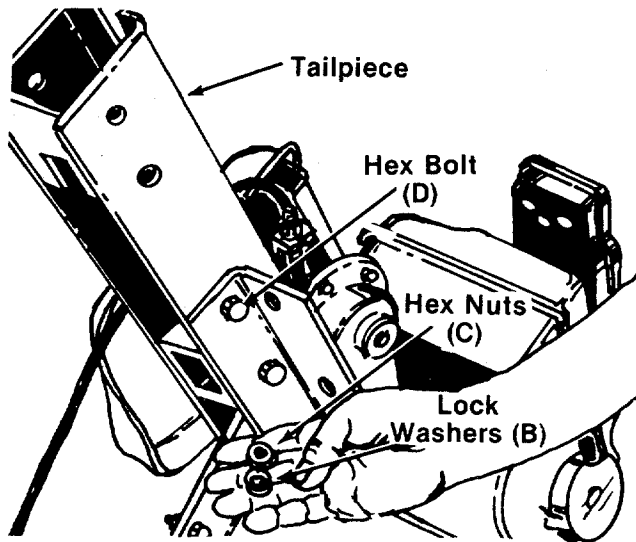

FIGURE 4.

4. Secure the tailpiece to the rear frame rails with two hex bolts (D), lock washers (B) and hex nuts (C). See figure 4. Tighten all four hex bolts and nuts securely. Two 1/2" wrenches are required.

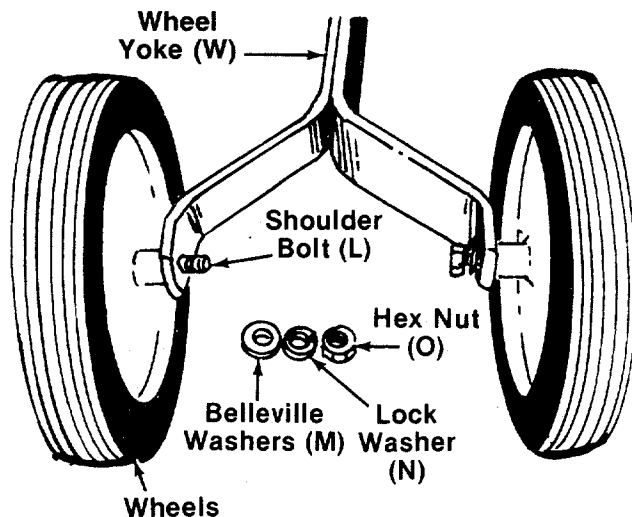

FIGURE 5.

5. Assemble wheels (AC) to wheel yoke (W) with shoulder bolts (L), belleville washers (M) (cupped side of washer is against the wheel yoke), lock washers (N) and hex nuts (O) as shown in figure 5. A 3/4" wrench and an adjustable wrench is required.

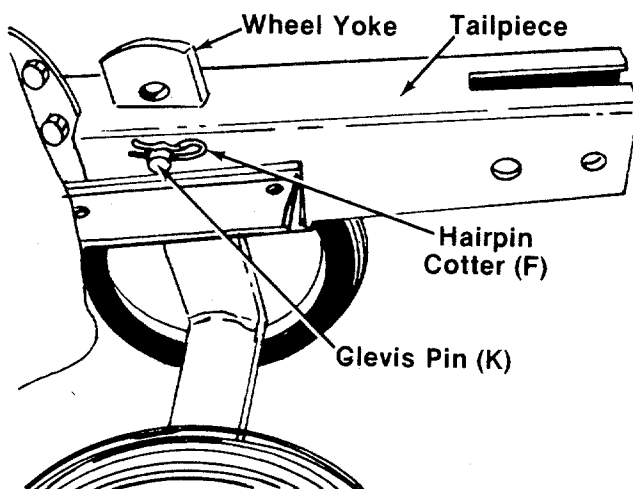
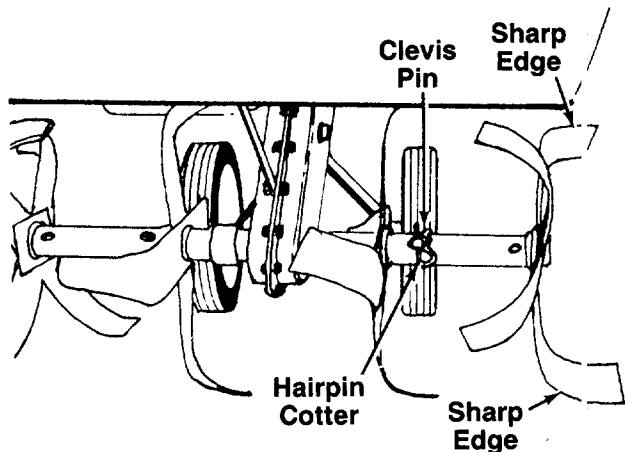

FIGURE 6.

6. Place the end of the wheel yoke up through the rectangular hole in the tailpiece. Secure with clevis pin (K) and hairpin cotter (F). See figure 6.



7. Remove the clevis pin and hairpin cotter from the inner tine assemblies as shown in figure 7. Place the right and left hand tine assemblies in position on tine shaft. Secure with clevis pins and hairpin cotters.

**NOTE**

Be certain the tine assemblies are assembled on the tine shaft so that the sharp edge of the tines enter the soil first. See figure 7.

**FIGURE 7.**

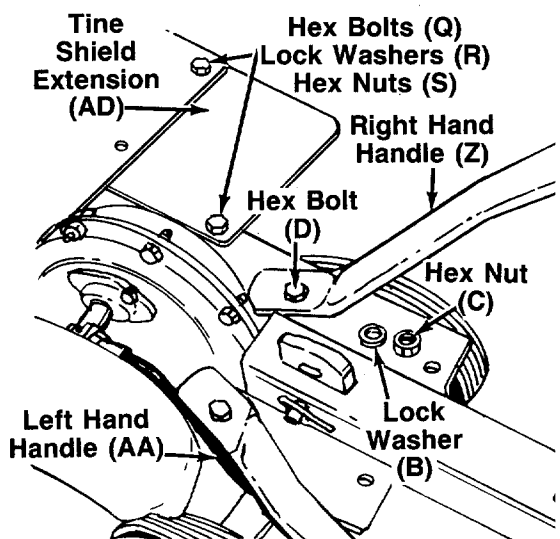

8. Attach the tine shield extension (AD) to the tine shield and frame on the right side of the unit as shown in figure 8. Secure with hex bolts (Q), lock washers (R) and hex nuts (S). Tighten securely.
9. The left handle has a clutch grip already assembled to it. Assemble the left and right hand handles (AA and Z) to the rear tiller frame as shown in figure 8. Secure with hex bolts (D), lock washers (B) and hex nuts (C), finger tight only (do not tighten).

**FIGURE 8.**

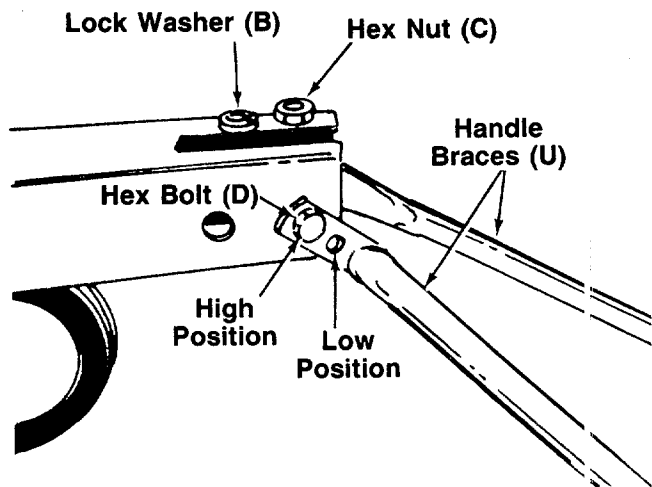

10. Attach the right and left hand braces (U) to the tailpiece. The braces have two holes to provide handle height adjustment. Select hole for either high or low position. Secure to tailpiece with hex bolts (D), lock washers (B) and hex nuts (C), finger tight only (do not tighten). See figure 9.

**FIGURE 9.**

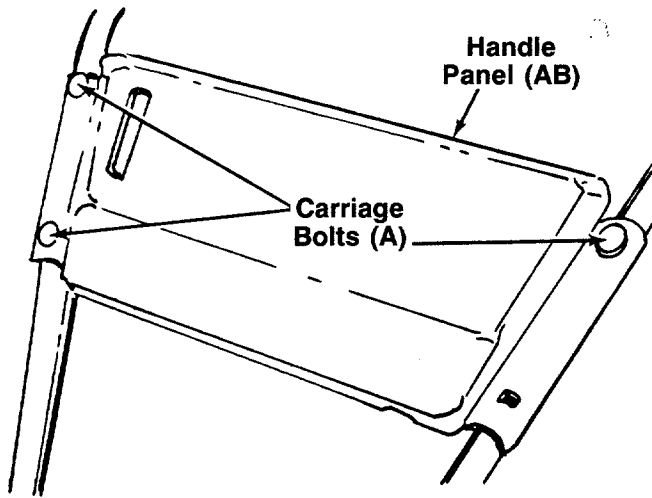

FIGURE 10.

11. Place the handle panel (AB) in position on the handles. Secure the upper holes in the panel to the handles with carriage bolts (A), lock washers (B) and hex nuts (C), finger tight only. See figure 10.
12. Place carriage bolt (A) through the handle panel, handle and handle brace on the lower right hand side of the handle panel, finger tight only. See figure 10.

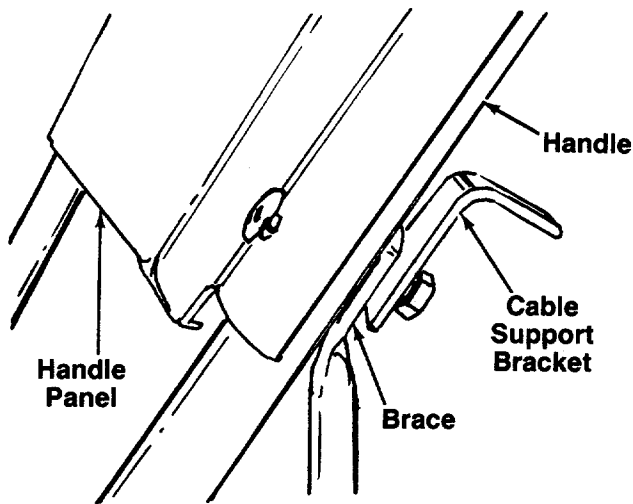

FIGURE 11.

13. Place carriage bolt (A) through the handle panel, handle, handle brace and cable support bracket on the lower left hand side of handle panel as shown in figure 11. Use the bottom hole in the cable support bracket. Secure with lock washer and hex nut, finger tight only.

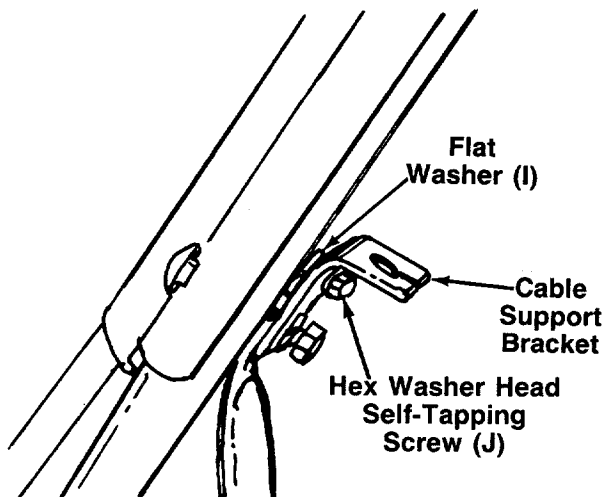

FIGURE 12.

14. Place flat washer (I) between handle and upper hole on cable support bracket. Secure with hex washer head self-tapping screw (J). See figure 12.
15. Now tighten securely the self-tapping screw and all nuts and bolts on handles and braces.

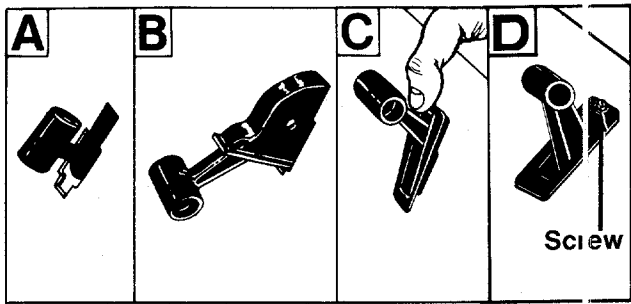

FIGURE 13.

16. Assemble the throttle control to the handle panel as follows.

- A. Hold the throttle control assembly beneath the handle panel. Turn the control sideways and insert the lever up through the wide portion of the slot on the handle panel. See figure 13A.
- B. After the end of the lever is through the slot, turn and then tip the control forward as shown in figure 13B to slide it through the slot.

**NOTE**

The lever must be all the way to the back of the control housing as shown in figure 13B.

- C. Push the control back into the slot in the handle panel and press in place. Be certain the control is locked securely into the slot. See figure 13C.

- D. Secure the throttle control to the handle panel using phillips head self-tapping screw provided. See figure 13D.

17. Hook the end of the clutch cable (already attached to the tiller) over the extension spring as shown in figure 14.

**NOTE**

If spring has come loose, it must be reassembled to the weld pin on the idler bracket.

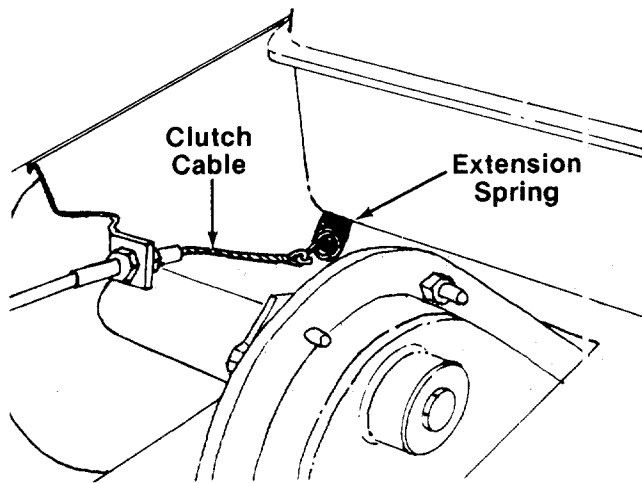

FIGURE 14.

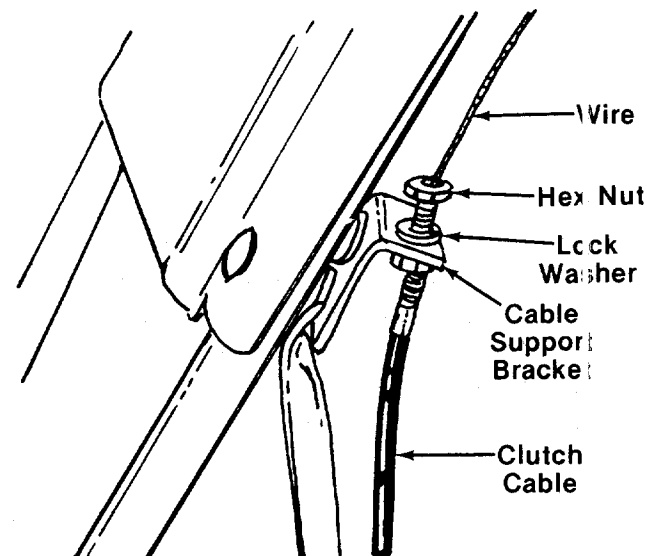

FIGURE 15.

18. Remove one nut and lock washer from other end of clutch cable. Slip the wire up through slot on cable support bracket. Start hex nut and lock washer back on end of clutch cable. See figure 15. Do not tighten at this time.



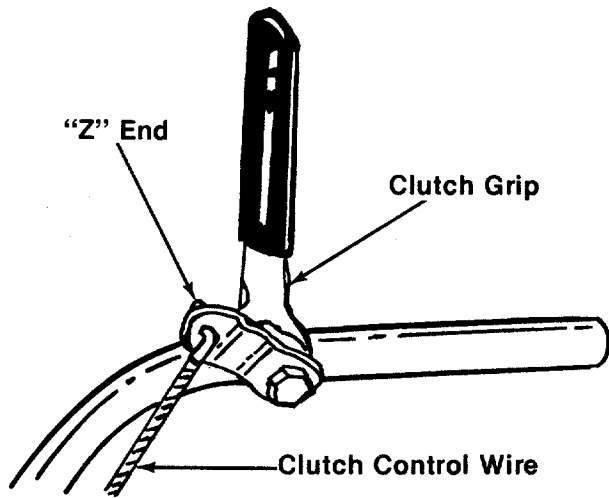

FIGURE 16.

19. Hook the "Z" end of clutch cable wire into clutch grip. See figure 16.

Hold the clutch grip so that the grip is down against the handle. Adjust the clutch control cable so that the slack is taken out of the control wire. Tighten the two hex nuts at the cable support bracket. Control wire should now be straight.

**NOTE**

Do not overtighten control wire. Too much tension may cause it to break.

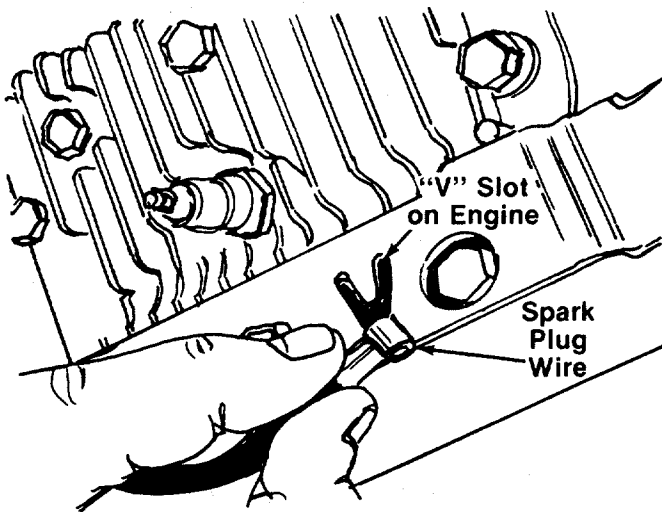

FIGURE 17.

20. To check the adjustment, disconnect the spark plug wire from spark plug to prevent accidental starting. Secure end of spark plug wire in the "V" slot on the engine. See figure 17. With the clutch grip released (neutral position), pull starter cord several times. **The tines should not turn.** If they do, adjust the hex nuts at the cable support bracket. Check again for correct adjustment.

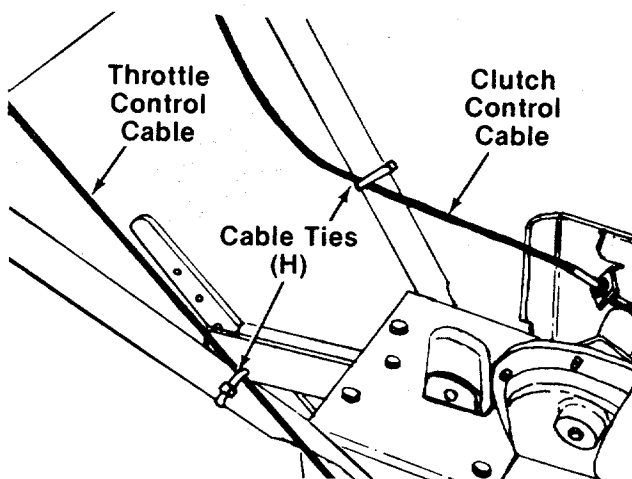

FIGURE 18.

21. Secure the throttle control cable and clutch control cable to the handle and brace with cable ties (H) provided. Cut off excess ends. See figure 18.

22. Assemble the grips to the ends of the upper handles. They will slip on more easily if they are first soaked in warm, soapy water.

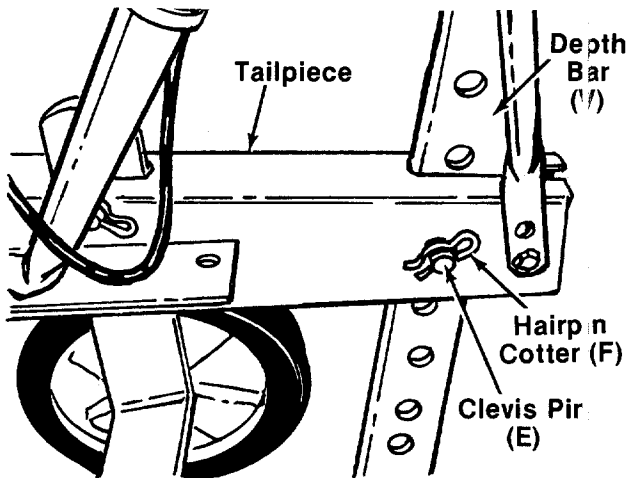

FIGURE 19.

## OPERATION

### GAS AND OIL FILL-UP

Service the engine with gasoline and oil as instructed in the separate engine manual packed with your tiller. Read instructions carefully.

#### NOTE

Your tiller is shipped without oil; however, a small amount of oil may be present from the factory.

### TO START ENGINE



BE SURE NO ONE IS STANDING IN FRONT OF THE TILLER WHILE THE ENGINE IS RUNNING OR BEING STARTED.

1. Attach spark plug wire to spark plug.
2. Move the throttle control lever forward to FAST position. See figure 20.

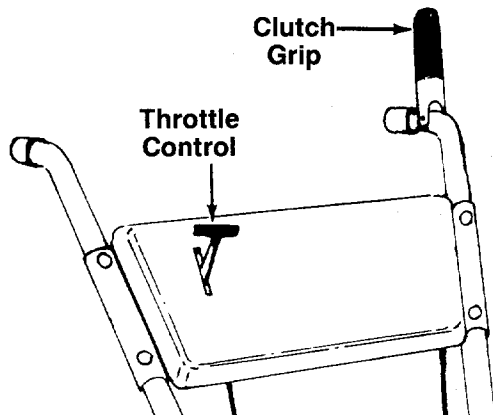

FIGURE 20.

23. Place the depth bar (V) in position on the tailpiece. Secure with clevis pin (E) and hairpin cotter (F). See figure 19.

3. Move choke lever to CHOKE position. See figure 21. After the engine starts, gradually push the choke lever off.

#### NOTE

A warm engine may not require choking.

4. Stand at side of the tiller, grasp the starter handle and pull out rapidly. Return it slowly to the engine. Repeat if necessary.

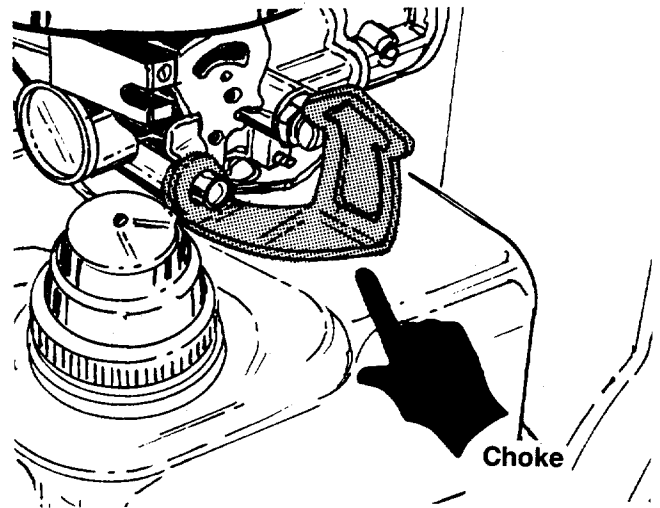

FIGURE 21.

### TO STOP ENGINE

Move throttle control lever to STOP position. See figure 20.

### TO ENGAGE TINES

To engage the tines, squeeze the clutch grip. To stop the tines, release the clutch grip. See figure 20.

# HOW TO USE YOUR TILLER

The tiller is a precision built machine designed for seed bed preparation, cultivating, furrowing and mulching. It is engineered to minimize the hardest work in the vegetable or flower garden, to till the soil for planting and cultivating, and for performing many other useful labor saving tasks in the garden. With the proper amount of care and maintenance, this machine will provide the owner with many years of excellent service.

## WHEEL POSITION

During digging as the tines enter the ground and the front of the tiller lowers, the wheels must be raised to level the unit. This is essential for proper engine operation. This adjustment is made by removing the clevis pin and hairpin cotter from wheel yoke, raising the wheels to the desired height, and replacing the clevis pin and hairpin cotter. See figure 22.

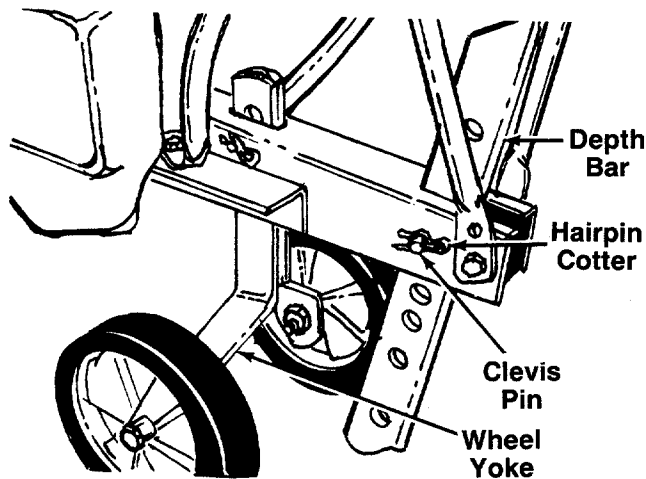
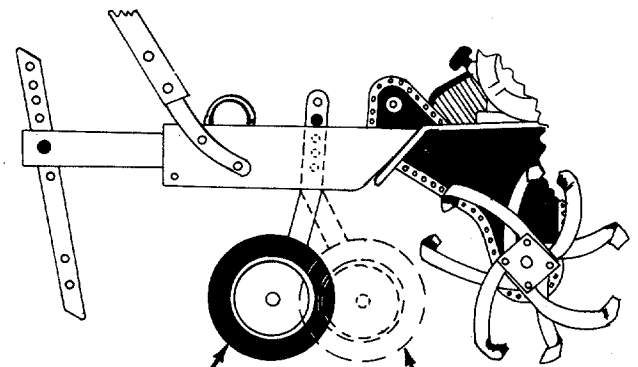

FIGURE 22.

## CONTROLLING SPEED AND TILLING DEPTH:

1. **Wheel Yoke Adjustment:** Place wheel yoke so that the wheels are forward (nearest point between wheels and tines) for shallow tilling, cultivating and transport. This will also increase the forward speed. See figure 23. Turn yoke around (farthest point between wheels and tines) for deep tilling. Forward speed will decrease. See figure 23.



Wheel Yoke in this position for deep dig.

Wheel Yoke in this position for shallow dig, cultivating and transport.

FIGURE 23.

2. **Depth Bar Adjustment:** The depth bar acts as a brake for the tiller and controls the depth and speed at which the machine will operate. See figure 24. Remove the clevis pin and hairpin cotter to raise or lower depth bar.

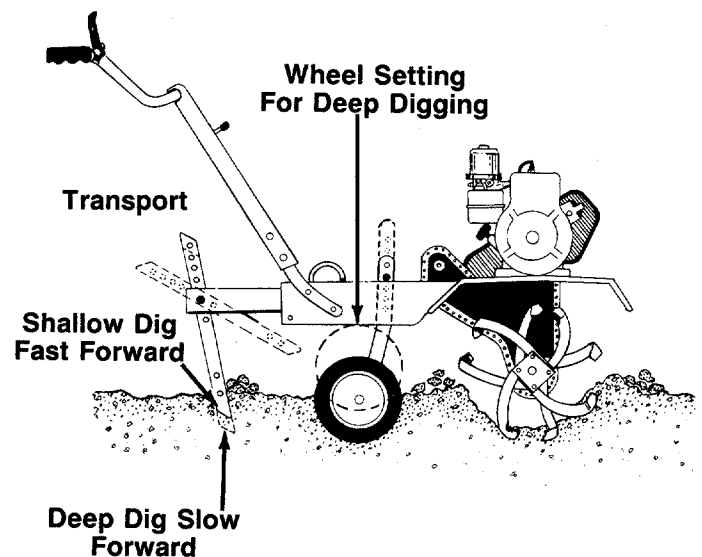

FIGURE 24.

By increasing the depth of the depth bar, the forward speed of the machine is reduced, and the working depth is increased. When the depth bar is raised, the working depth of the machine is reduced and the forward speed is increased. The working depth of the machine may be predetermined by setting the depth bar and wheels so that the wheels are about four inches from the ground when the tines and depth bar are resting on the ground. This setting will permit a working depth of about four inches.

In some soils, the desired depth is obtained the first time over the garden. In other soils, the desired depth is obtained by going over the garden two or three times. In the latter case, the depth bar should be lowered before each succeeding pass over the garden, and passes should be made across the length and width of the garden alternately. Rocks which are turned up should be removed from the garden area.

- 3. Handle Pressure:** Further control of tilling depth and travel speed can be obtained by variation of pressure on the handles. A downward pressure on the handles will reduce the working depth and increase the forward speed. An upward pressure on the handles will increase the working depth and reduce the forward speed. The type of soil and working conditions will determine the actual setting of the depth bar and the handle pressure required.
- 4. Throttle Control:** The throttle control lever adjusts the engine speed and stops the engine. With the throttle control knob pushed completely forward, the carburetor is in START position. Pulling the throttle control back slightly adjusts the engine speed to FAST. Pulling the throttle back further reduces the engine speed to SLOW. Pull the throttle completely back to stop the engine. See figure 20.

Use maximum engine speed for deep tilling. Move the throttle control to SLOW when transporting the tiller.

## TRANSPORTING THE TILLER

To transport the tiller to or from the garden, raise the depth bar to the highest position. See figure 24. With the throttle control in SLOW position, the unit will move under its own power, without damaging grass areas as long as it is allowed to move freely. If the operator holds back, it will start to dig.

## CULTIVATING

For cultivating, a two to three inch depth is desirable. Setting the wheels and depth bar so that the wheels are about two inches above the ground while the tiller is resting on the tines and depth bar will allow the machine to work at cultivating depth. The throttle should be set to control forward movement to a slow walking speed. With outer tines installed, the maximum working width of the tiller is 26 inches. This width may be reduced to 24 inches by moving the clevis pins and hairpin cotter to the inner holes on the tine shaft. For cultivation, remove the outer tines to obtain a tilling width of 13 inches.

When laying out plant rows, be sure to allow enough width to permit cultivation between the rows. In growing corn or similar crops, check-row planting will permit cross cultivation and practically eliminate hand hoeing.

The tiller has many uses other than tilling and cultivating a garden. One of these is the preparation of lawn area for seeding. The tiller will prepare a deep seed bed which will be free of hard untilled spots, allowing a better stand of grass to grow. The tiller is very useful for loosening hard soil for excavation with a shovel. No tedious hand pickwork will be necessary. Your tiller may be used for mixing compost in the pile, or for mixing it with the soil in your garden. This should be done after the soil has been broken to the full working depth. The compost should be worked in to a depth of six to eight inches. This may be done by working the length of the garden, and then by making separate passes across its width. The addition of decayed organic matter will substantially increase the fertility of your garden. For proper decaying action, fertilizer should be applied and worked in with the mulch materials. Breaking up leaves and straw and mixing it with several inches of soil causes the soil to hold moisture longer and allows proper aeration of the plant root system. It also retards the growth of weeds.

The U.S. Department of Agriculture and various state and local agencies offer published booklets and expert advice on all phases of gardening. They should be consulted regarding soil information, planting dates, and the most satisfactory varieties of crop for your particular area.

## ADJUSTMENTS



Disconnect the spark plug wire and ground against the engine before performing any adjustments, repairs or maintenance.

### WHEEL ADJUSTMENT

To adjust the wheel yoke and wheel position, refer to "How To Use Your Tiller" on page 11.

### DEPTH BAR ADJUSTMENT

To adjust the depth bar, refer to "How To Use Your Tiller" on page 11.

### TINE CLUTCH CONTROL ADJUSTMENT

To adjust the tine clutch control, refer to step numbers 19 and 20 under assembly instructions.

## CARBURETOR ADJUSTMENT



### WARNING

If any adjustments are made to the engine while the engine is running (e.g. carburetor), disengage all clutches and tines. Keep clear of all moving parts and be careful of heated surfaces and muffler.

Minor carburetor adjustment may be required to compensate for differences in fuel, temperature, altitude or load.

### NOTE

A DIRTY AIR CLEANER WILL CAUSE ENGINE TO RUN ROUGH. BE CERTAIN AIR CLEANER IS CLEAN AND ATTACHED TO THE CARBURETOR BEFORE ADJUSTING CARBURETOR.

Never make unnecessary adjustments. The factory recommended settings are correct for most applications.

If adjustments are needed, refer to the engine manual packed with the tiller.

## LUBRICATION

### CHAIN CASE

The chain case is pre-lubricated and sealed at the factory. It requires no checking unless the chain case is disassembled. To fill with grease, lay the left half of the chain case on its side, add 12 ounces of Plastilube #0 grease and assemble the right half to it. This grease can be obtained at your nearest authorized dealer. Order Part Number 737-0133.

## MAINTENANCE

### ENGINE OIL

Change the oil in the crankcase after the first two hours of operation of your new engine and after each 25 hours of use thereafter to insure proper lubrication of internal parts. (Take care to remove dirt around plugs.) Be sure oil level is maintained full to point of overflowing. See figure 25.

To change oil, remove drain plug and tip the tiller forward while engine is warm. Replace drain plug. Remove oil fill plug and refill with new oil of proper grade as instructed in the engine manual. Replace oil fill plug.

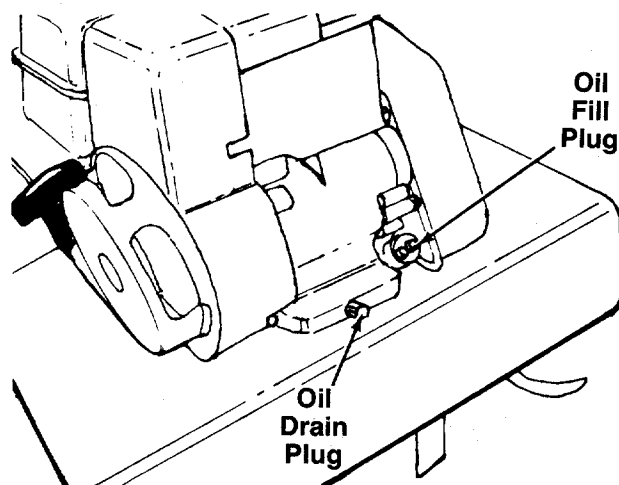

FIGURE 25.

### AIR CLEANER

The air cleaner prevents damaging dirt, dust, etc., from entering the carburetor and being forced into the engine and is important to engine life and performance.

To service air cleaner, refer to the engine manual packed with the tiller.

**Never run your engine without air cleaner completely assembled.**

### CLEAN ENGINE

Wipe off all spilled fuel and oil. Keep the engine clean of foreign matter and be sure the cooling fins on the cylinder are kept clean to permit proper air circulation. This is an air-cooled engine and free flow of air is essential to proper engine performance and life.

### SPARK PLUG

The spark plug should be cleaned and the gap reset at least once a season or when oil is changed. Spark plug replacement is recommended at the start of each mowing season; check engine manual for correct plug type and gap specification.

### BELT REPLACEMENT

If belt replacement is required, order belt or belts by part number from your nearest authorized dealer.

1. Remove the belt cover by removing three self-tapping screws. A 3/8" wrench is required. See figure 26.

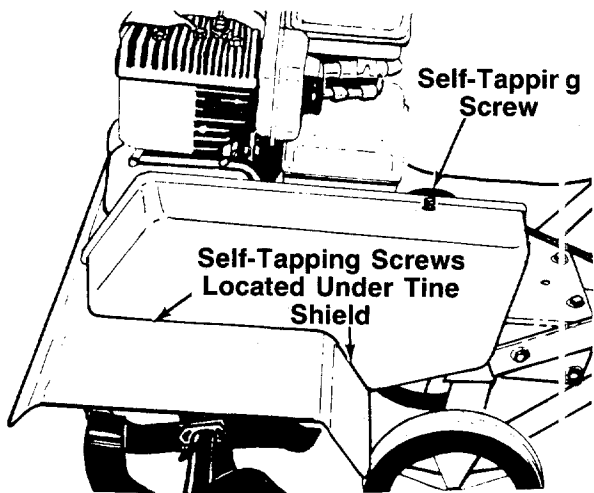

FIGURE 26.

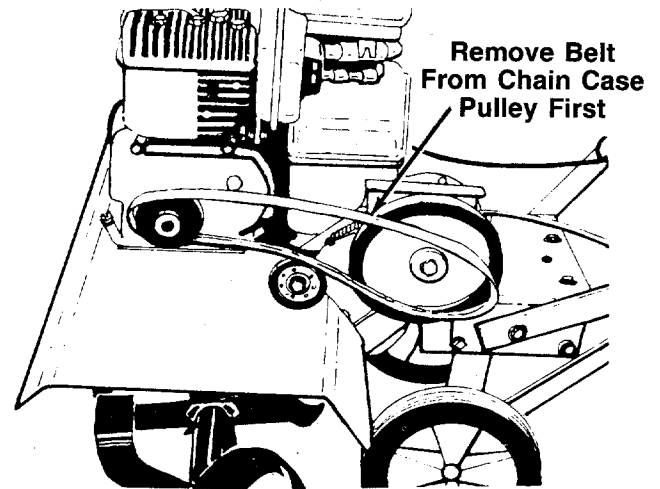

FIGURE 28.

2. After removing three screws, lift off belt cover. See figures 26 and 27.
3. Slip the belt off the chain case pulley first, then off idler pulley. Remove belt from engine pulley. See figure 28.
4. To reassemble the new belt, first place belt over engine pulley. Be sure belt is inside two pins at engine pulley. See figure 27.
5. Belt must be over top of idler pulley. See figure 27. Slip end of belt over the chain case pulley.
6. Reassemble the belt cover. See figure 26.

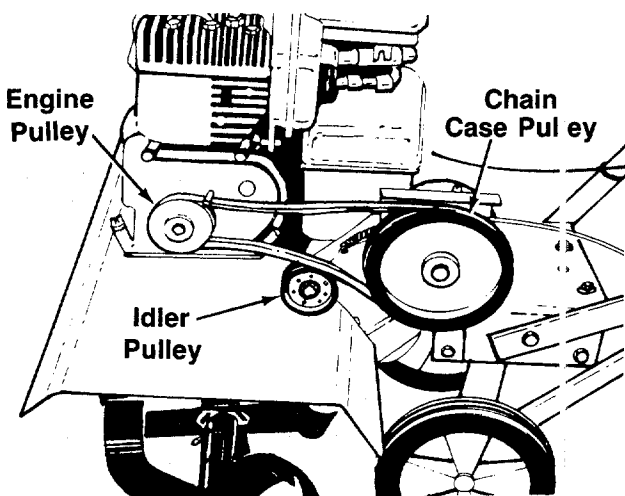

FIGURE 27.

## OFF-SEASON STORAGE

If the tiller is not to be used for a while, the following procedure should be followed. The tines, depth bar, chain case and wheels should be cleaned of all dirt. It is very important that the unit be stored in a level position to prevent engine oil from draining into the cylinder head cavity.

Engines on tillers to be stored between seasons should be completely drained of fuel to prevent gum deposits forming on essential carburetor parts and fuel tank. Refer to the engine manual for correct engine storage instructions.

Just as your automobile needs professional mechanical maintenance from time to time, so does your air-cooled engine. Cleaning and adjusting of the carburetor and periodic replacement of the spark plug and ignition points is made necessary by NORMAL use.

Professional Air-Cooled Engine Service is as close as your telephone book.

A yearly checkup or tune-up by an authorized engine dealer is a good idea to avoid breakdowns or delay... do it at the end of the season, then you're ready for the next.

### ➔ NOTE

When storing any type of power equipment in an unventilated or metal storage shed, care should be taken to rustproof the equipment. Using a light oil or silicone, coat the equipment, especially any chains, springs, bearings and cables.

## TROUBLE SHOOTING CHART

SYMPTOM	POSSIBLE CAUSE(S)	SOLUTION
Engine fails to start	<ol style="list-style-type: none"> <li>1. Check fuel tank for gas.</li> <li>2. Spark plug lead wire disconnected.</li> <li>3. Faulty spark plug.</li> </ol>	<ol style="list-style-type: none"> <li>1. Fill tank if empty.</li> <li>2. Connect lead wire.</li> <li>3. Clean, adjust gap or replace.</li> </ol>
Hard starting or loss of power	<ol style="list-style-type: none"> <li>1. Spark plug wire loose.</li> <li>2. Dirty air cleaner.</li> </ol>	<ol style="list-style-type: none"> <li>1. Connect and tighten spark plug wire.</li> <li>2. Clean air cleaner as described in engine manual.</li> </ol>
Engine overheats	<ol style="list-style-type: none"> <li>1. Carburetor not adjusted properly.</li> <li>2. Air flow restricted.</li> <li>3. Engine oil level low.</li> </ol>	<ol style="list-style-type: none"> <li>1. Adjust carburetor. See engine manual.</li> <li>2. Remove blower housing and clean as described in the engine manual.</li> <li>3. Fill crankcase with the proper oil.</li> </ol>
Tine control does not engage.	Belt worn and/or stretched.	Make control cable adjustment (see Assembly Instructions) or replace belt.

NOTE: For repairs beyond the minor adjustments listed above, please contact your local authorized service dealer.

### Heavy Duty Garden Tiller Attachments Available for All-Season Use

- |   |  |
|---|--|
| <p>31-0106 Depth Gauge Wheels (Pair)</p> <p>31-0107 6-Tine Cultivator (Must be used with 31-0106 Depth Gauge Wheels)</p> <p>31-0110 8" Furrow Opener</p> <p>31-0111 15" Sweep Cultivator</p> <p>31-0113 Pneumatic Tires, 13 x 5.00-6 (Pair)</p> <p>31-0114 Wheel Weights (Pair)</p> <p>31-0115 Tire Chains, 13 x 5.00 (2 Link) (Pair)</p> <p>31-0119 Tine Cultivating Shields w/Adapters (Pair)</p> | <p>31-0123 Lawn Aerator (Use with 31-0114 Wheel Weights for added penetration)</p> <p>31-0144 "V"-Bar Cultivating Kit<br/>Kit Includes: "V"-Bar Frame, 4-Point Cultivating Tines, Hiller/Furrower, Depth Gauge Wheels (Pair).</p> <p>31-0145 Depth Stake Cultivating Kit<br/>Kit Includes: 8" Furrow Opener, 15" Sweep Cultivator, 32" Leveling Rake, Extra Depth Stake.</p> |
|---|--|

Note: Attachments are available through your local dealer or from the factory:  
Agri-Fab Inc., 303 W. Raymond Street, Sullivan, Illinois 61951 (217) 728-4334

# Model 310

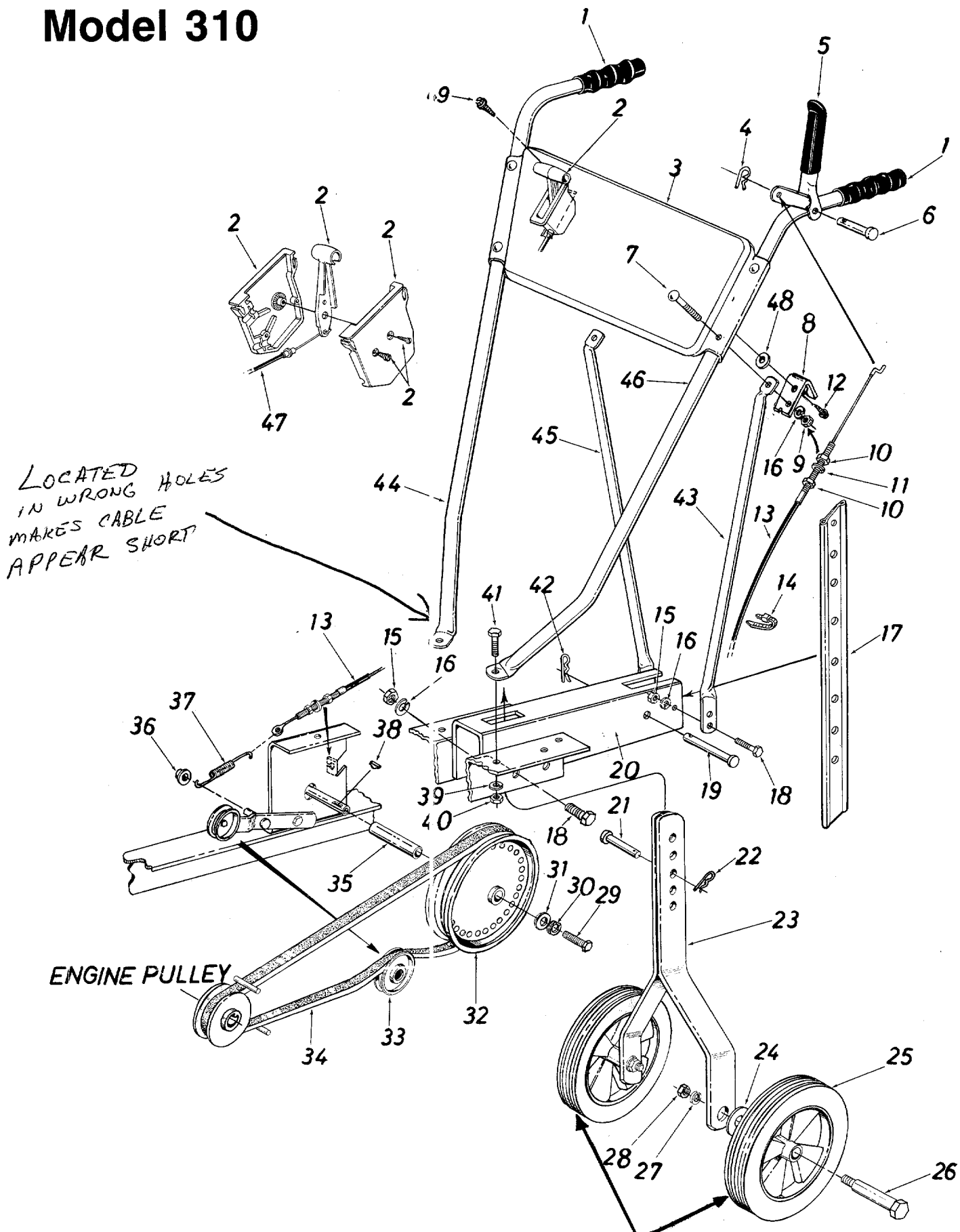

16 \* 50 OTASCO'S WITH 9" PLASTIC INSTEAD OF 9" STEEL; CHANGED TO 10" STEEL WHEELS PART No. 734-0584



# Model 310

## PARTS LIST FOR MODEL 310 TILLER

EF. NO.	PART NO.	COLOR CODE	DESCRIPTION	NEW PART	REF. NO.	PART NO.	COLOR CODE	DESCRIPTION	NEW PART
1	720-0204	463	Grip		26	738-0318		Shoulder Bolt	
2	831-0823		Throttle Control Box		27	736-0921		L-Wash. 1/2" I.D.*	
3	784-0036		Handle Panel		28	712-0200		Hex Nut 1/2-20 Thd.*	
4	714-0104		Int. Cotter Pin		29	710-0412		Hex Bolt 1/4-28 x .75" Lg.	
5	784-0008		Clutch Grip Ass'y.		30	736-0329		L-Wash. 1/4" I.D.*	
6	711-0415		Clevis Pin		31	736-0176		FI-Wash. .25" I.D. x .930" O.D.	
7	710-0458		Carriage Bolt 5/16-18 x 1.75" Lg.*		32	756-0389		Pulley 6.00" O.D.	
8	15093	Cable Support Brkt.		33	756-0137		Idle Pulley		
9	712-0267	Hex Nut 5/16-18 Thd.*		34	754-0190		"V"-Belt 1/2" Pitch x 39" Lg.		
10	712-0256	Hex Jam Nut 5/16-24 Thd.		35	750-0472		Spacer		
11	736-0119	L-Wash. 5/16" I.D.*		36	726-0106		Cap Speed Nut		
12	710-0599	Hex Wash. Hd. Self-Tap Scr. 1/4-20 x .50" Lg.		37	732-0387		Extension Spring		
13	746-0508	Clutch Control Cable		38	714-0388		Hi-Pro Key		
14	725-0157	Cable Tie		39	736-0119		L-Wash. 5/16" I.D.*		
15	712-0267	Hex Nut 5/16-18 Thd.*		40	712-0267		Hex Nut 5/16-18 Thd.*		
16	736-0119	L-Wash. 5/16" I.D.*		41	710-0118		Hex Bolt 5/16-18 x .75" Lg.*		
17	04668	Depth Bar		42	714-0149		Hairpin Cotter		
18	710-0118	Hex Bolt 5/16-18 x .75" Lg.*		43	749-0633		Handle Support Bracket—L.H.		
19	711-0761	Clevis Pin 1/2" Dia. x 2.50" Lg.		44	749-0626		Handle Bar—R.H.		
20	784-0005	Tailpiece Ass'y.		45	749-0632		Handle Support Bracket—R.H.		
21	711-0755	Clevis Pin 3/8" Dia. x 2.50" Lg.		46	749-0627		Handle Bar—L.H.		
22	714-0149	Hairpin Cotter		47	746-0503		Throttle Control Cable—35"		
23	06813	Wheel Bracket Ass'y.		48	736-0142		FI-Wash. .281" I.D. x .50" O.D.		
24	736-0253	Belleville Wash. 1/2" I.D.		49	710-0779		Self-Tap Scr. #10 x 1/2" Lg.		
25	734-0968	Wheel Ass'y. 9 x 1.75							

\*For faster service obtain standard nuts, bolts, and washers locally. If these items cannot be obtained locally, order by part number and size as shown on parts list.

NOTE: The engine is not under warranty by the tiller manufacturer... If repairs or service is needed on the engine, please contact your nearest authorized engine service outlet. Check the "Yellow Pages" of your telephone book under "Engines—Gasoline."



This instruction manual covers various models, and all specifications shown do not necessarily apply to your model. Specifications subject to change without notice or obligation.

If color or finish is important when ordering parts, use the appropriate color code shown below [i.e. (part no.)-463 for Topflite Red Finish].

### Color Codes

312—White	463—Topflite Red
436—Radiant Yellow	480—Brilliant Green
447—Patina Silver	483—Charcoal Grey
452—Black	499—Beige
456—Radiant Tangerine	606—Majestic Orange
460—Green Flake	629—Silver Flake

# Model 310

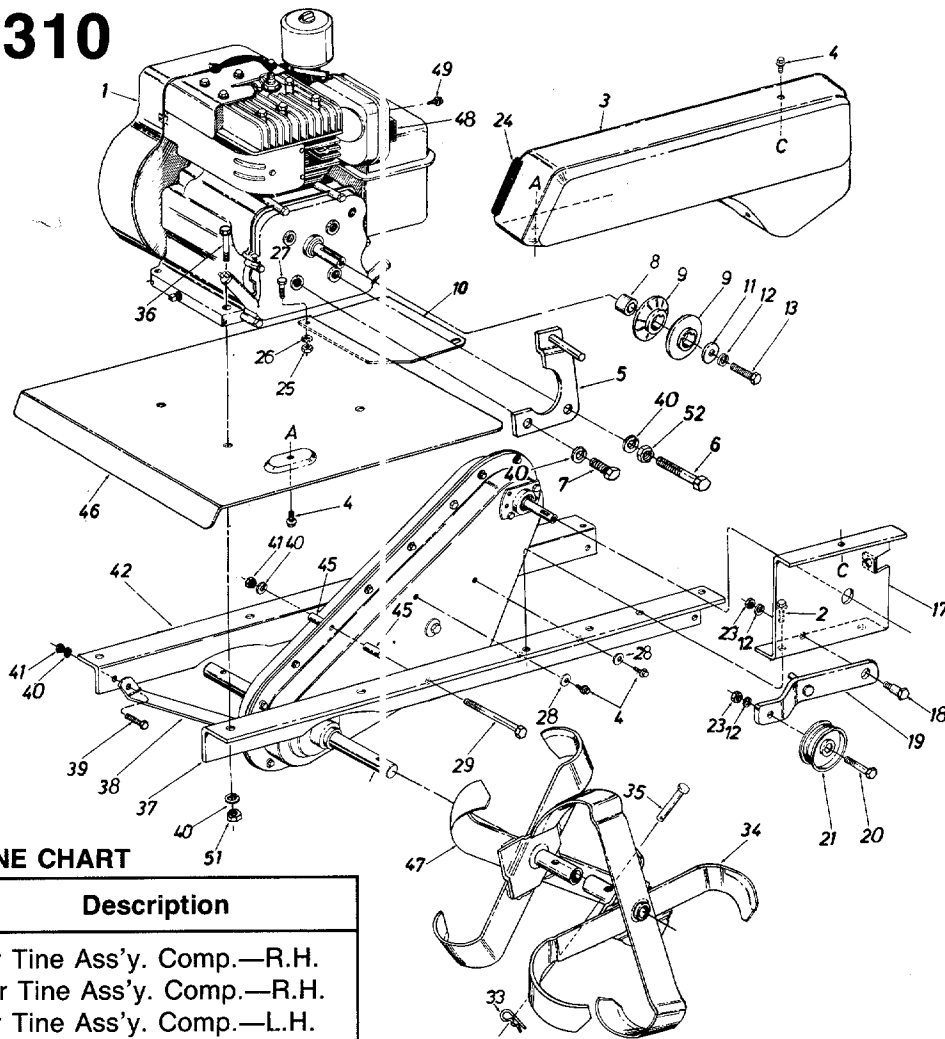

**TINE CHART**

Part No.	Description
784-0092	Inner Tine Ass'y. Comp.—R.H.
784-0094	Outer Tine Ass'y. Comp.—R.H.
784-0091	Inner Tine Ass'y. Comp.—L.H.
784-0093	Outer Tine Ass'y. Comp.—L.H.

## PARTS LIST FOR MODEL 310 TILLER

REF. NO.	PART NO.	COLOR CODE	DESCRIPTION	NEW PART	REF. NO.	PART NO.	COLOR CODE	DESCRIPTION	NEW PART
1	—		Engine		25	712-0287		Hex Nut 1/4-20 Thd.*	
2	710-0600		Hex Self-Tap Scr. 5/16-24 x .5"		26	736-0329		L-Wash. 1/4" I.D.*	
3	04958	463	Belt Cover		27	710-0258		Hex Bolt 1/4-20 x .62 Lg.*	
4	710-0599		Hex Self-Tap Scr. 1/4-20 x .5"		28	736-0270		Bell-Wash. .26 I.D. x .75 O.D.	
5	784-0114		Belt Keeper Brkt. Ass'y.		29	710-0189		Hex Bolt 5/16-18 x 3" Lg.*	
6	710-0593		Hex Bolt 5/16-24 x 2.25" Lg. (Gr. 5)		33	714-0149		Hairpin Cotter	
7	710-0237		Hex Bolt 5/16-24 x .62" Lg. (Gr. 5)		34	—		See Tine Chart	
7	710-0121		Hex Bolt 1/2-20 Thd. (Special)		35	1545-029		Clevis Pin	
8	750-0345		Spacer		36	710-0442		Hex Bolt 5/16-18 x 1.5" Lg.*	
9	748-0282		Pulley Half		37	04949	463	Frame Rail—L.H.	
10	784-0265		Tine Shield Extension		38	04933		Front Brace Brkt.	
11	736-0258		Fl-Wash. 3/8" I.D. x 1.25"		39	710-0118		Hex Bolt 5/16-18 x .75" Lg.*	
12	736-0169		L-Wash. 3/8" I.D.*		40	736-0119		L-Wash. 5/16" I.D.*	
13	710-0152		Hex Bolt 3/8-24 x 1.00" Lg.		41	712-0158		Hex Cent. L-Nut 5/16-18 Thd.	
17	04934	463	Idler Mounting Brkt.		42	04948	463	Frame Rail—R.H.	
18	738-0322		Shld. Bolt		45	750-0470		Spacer	
19	784-0027		Idler Bracket Ass'y.		46	784-0001		Tine Shield	
20	710-0344		Hex Bolt 3/8-16 x 1.5" Lg.		47	—		See Tine Chart	
21	756-0137		Idler Pulley		48	751-0233		Deflector	
23	712-0342		Hex Jam Nut 3/8-16 Thd.		49	710-0783		Hex Self-Tap Scr. #8-32 x .38" Lg.	
24	731-0511		Trim Strip—3"		51	712-0267		Hex Nut 5/16-18 Thd.*	
					52	712-0123		Hex Nut 5/16-24 Thd.*	

# Model 310

# Chain Case Assembly 784-0103

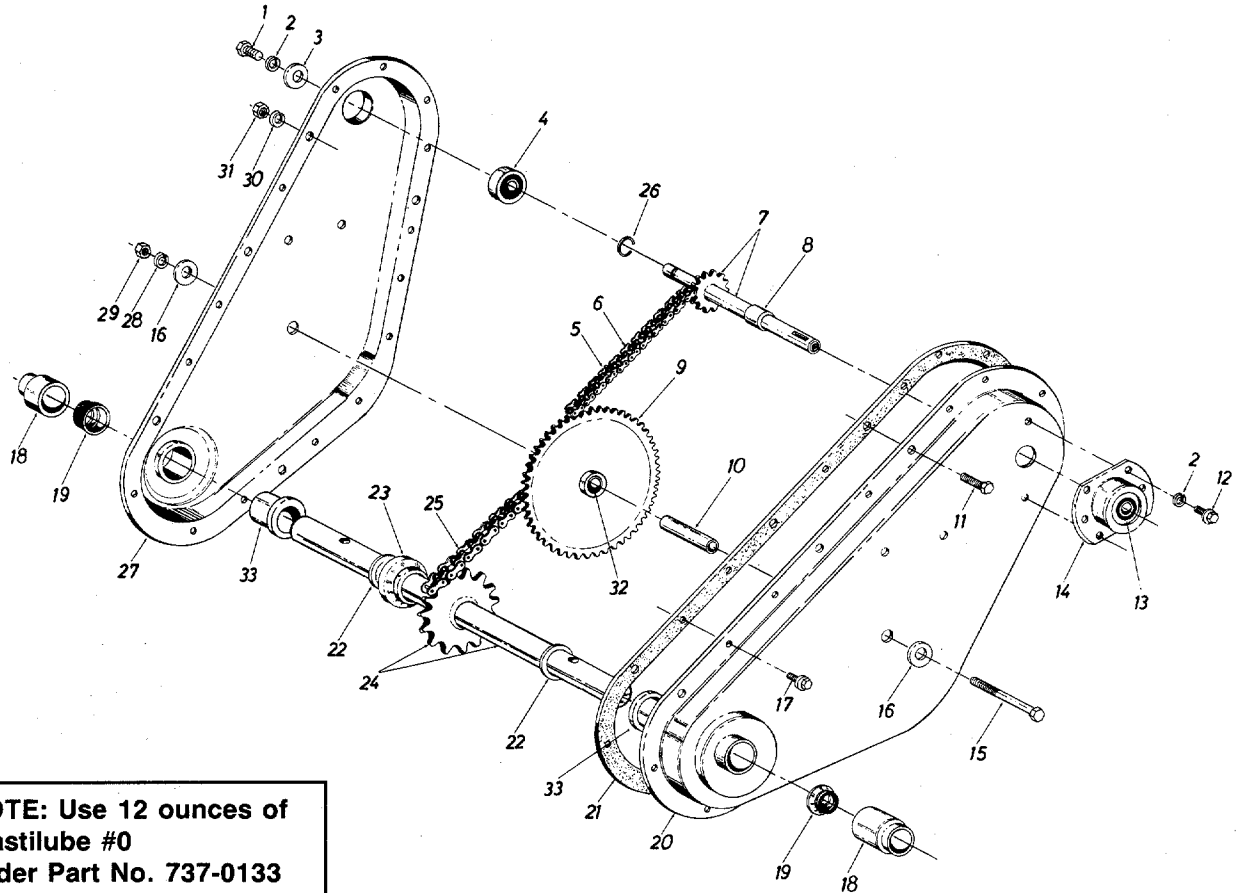

**NOTE: Use 12 ounces of  
Plastilube #0  
Order Part No. 737-0133**

### PARTS LIST FOR CHAIN CASE 784-0103

REF. NO.	PART NO.	COLOR CODE	DESCRIPTION	NEW PART	REF. NO.	PART NO.	COLOR CODE	DESCRIPTION	NEW PART
1	710-0513		Hex L-Scr. 1/4-28 x .625" Lg.		17	710-0599		Hex Wash. Hd. Self-Tap Scr. 1/4-20 x .50" Lg.	
2	736-0329		L-Wash. 1/4" I.D.*		18	731-0487		Dust Cap	
3	736-0176		FI-Wash. .25" I.D. x .93" O.D. x .125" Thk.		19	721-0175		Seal	
4	741-0155		Bearing .62" I.D. x 1.38" O.D. x .437" Thk.		20	14985		Tiller Housing—L.H.	
5	713-0327		#35 Chain 3/8" Pitch x 52 Links—Endless		21	721-0170		Gasket	
6	713-0139		Master Link (Service Only)		22	736-0163		Thrust Wash. 1.00" I.D. x .030" Thk.	
7	04956		Input Shaft Assembly		23	750-0570		Step Spacer	
8	750-0471		Spacer		24	784-0089		Tine Shaft Assembly	
9	713-0331		Sprocket Assembly (Includes Ref. No. 32)		25	713-0328		#50 Chain 5/8" Pitch x 46 Links—Endless	
10	750-0275		Sprocket Hub Tubing 3/8" I.D. x 5/8" O.D. x 1.9" Lg.		26	716-0131		Snap Ring	
11	710-0118		Hex Scr. 5/16-18 x .625" Lg.*		27	14984		Tiller Housing—R.H.	
12	710-0599		Hex Wash. Hd. Self-Tap Scr. 1/4-20 x .50" Lg.		28	736-0169		L-Wash. 3/8" I.D.*	
13	741-0155		Bearing .625" I.D. x 1.38" O.D. x .437" Thk.		29	712-0711		Hex Nut 3/8-24 Thd.	
14	05034		Bearing Housing		30	736-0119		L-Wash. 5/16" Scr.*	
15	710-0629		Hex Scr. 3/8-24 x 2.75" Lg.		31	712-0267		Hex Nut 5/16-18 Thd.*	
16	736-0258		FI-Wash. 3/8" I.D. x 1.25" O.D. x .100 Thk.		32	741-0304		Bearing (For Service Only—Must be Press Fit)	
					33	731-0374		Bearing	

\*For faster service obtain standard nuts, bolts, and washers locally. If these items cannot be obtained locally, order by part number and size as shown on parts list.

# PARTS INFORMATION

## POWER EQUIPMENT PARTS AND SERVICE

Parts and service are available through the authorized service firms listed below. All orders should specify the model number of your unit, part numbers, description of parts and the quantity of each part required.

**NOTE:** If any parts are found to be missing or defective upon assembly of this unit, write to advise the factory so that immediate replacement can be made.

<b>ALABAMA</b>	<b>BIRMINGHAM</b>
Auto Electric & Carburetor Co. . . . .	2625 4th Ave. S. . . . . 05233
<b>ARKANSAS</b>	<b>NORTH LITTLE ROCK</b>
Sutton's Lawn Mower Shop . . . . .	5301 Roundtop Drive Box 368, Rt. 4 . . . . . 02117
<b>CALIFORNIA</b>	<b>PORTERVILLE</b>
Billious . . . . .	75 North D Street . . . . . 03257
<b>COLORADO</b>	<b>DENVER</b>
Spitzer Industrial Products Co. . . . .	6601 N. Washington St. . . . . 00229
<b>FLORIDA</b>	<b>JACKSONVILLE</b>
Radco Distributors . . . . .	4909 Victor St. Box 5459 . . . . . 02207
	<b>HIALEAH</b>
Small Eng. Dist. . . . .	7995 W. 26th Court . . . . . 03016
<b>GEORGIA</b>	<b>EAST POINT</b>
East Point Cycle & Key Inc. . . . .	2834 Church St. . . . . 00344
<b>ILLINOIS</b>	<b>LYONS</b>
Keen Edge Co. . . . .	8615 Ogden Ave. . . . . 00534
<b>INDIANA</b>	<b>ELKHART</b>
Parts & Sales Inc. . . . .	2101 Industrial Pkwy. . . . . 06516
<b>IOWA</b>	<b>DUBUQUE</b>
Power Lawn & Garden Equip. . . . .	2551 J.F. Kennedy . . . . . 02001
<b>LOUISIANA</b>	<b>NEW ORLEANS</b>
Suhren Engine Co. . . . .	8330 Earhart Blvd. . . . . 00118
<b>MARYLAND</b>	<b>TAKOMA PARK</b>
Center Supply Co. . . . .	6867 New Hampshire Ave. . . . . 00912
<b>MASSACHUSETTS</b>	<b>SPRINGFIELD</b>
Morton B. Collins Co. . . . .	300 Birnie Ave. . . . . 01107
<b>MICHIGAN</b>	<b>LANSING</b>
Lorenz Service Co. . . . .	2500 S. Pennsylvania . . . . . 08910
	<b>MOUNT CLEMENS</b>
Power Equipment Dist. . . . .	340 Hubbard . . . . . 08043
<b>MINNESOTA</b>	<b>HOPKINS</b>
Hance Distributing Inc. . . . .	420 Excelsior Ave. W. . . . . 05343
<b>MISSOURI</b>	<b>EARTH CITY</b>
Oscar Wilson Engine & Parts . . . . .	4159 Shoreline Dr. . . . . 03045
	<b>KANSAS CITY</b>
Automotive Equip. Service . . . . .	3117 Holmes St. . . . . 04109
	<b>ST. JOSEPH</b>
Ross-Frazier Supply Co. . . . .	8th and Monterey . . . . . 04503
	<b>ST. LOUIS</b>
Henzler, Inc. . . . .	2015 Lemay Ferry Rd. . . . . 03125
<b>NEW JERSEY</b>	<b>ALLOWAY</b>
Piersons . . . . .	Canal St. . . . . 08001
<b>NEW MEXICO</b>	<b>ALBUQUERQUE</b>
Spitzer Eng. & Parts Co. . . . .	1023 Third Ave. N.W. . . . . 07103

## BRIGGS AND STRATTON, TECUMSEH AND PEERLESS PARTS AND SERVICE

Briggs & Stratton, Tecumseh and Peerless parts and service should be handled by your nearest authorized engine service firm. Check the yellow pages of your telephone directory under the listing **Engines—Gasoli**. Briggs & Stratton or Tecumseh Lauson.

<b>NEW YORK</b>	<b>CARTHAGE</b>
Gamble Dist., Inc. . . . .	West End Ave. . . . . 13619
<b>NORTH CAROLINA</b>	<b>GREENSBORO</b>
Dixie Sales Company . . . . .	335 N. Green . . . . . 27402
<b>OHIO</b>	<b>CARROLL</b>
Stebe's Mid-State Mower Supply . . . . .	Box 366, 71 High St. . . . . 43112
	<b>CLEVELAND</b>
Bleckrie, Inc. . . . .	7900 Lorain Ave. . . . . 44102
	<b>WADSWORTH</b>
National Central . . . . .	687 Seville Rd. . . . . 44281
	<b>YOUNGSTOWN</b>
Burton Supply Co. . . . .	1301 Logan Ave. Box 929 . . . . . 44501
<b>OREGON</b>	<b>PORTLAND</b>
Kenton Supply Co. . . . .	8216 N. Denver Ave. . . . . 97217
<b>PENNSYLVANIA</b>	<b>HARRISBURG</b>
EECO Inc. . . . .	4021 N. 6th St. . . . . 17110
	<b>WILLOW GROVE</b>
Thompson Rubber Co. . . . .	850 Davisville Rd. . . . . 19090
	<b>PITTSBURGH</b>
Bluemont Co. . . . .	11125 Frankstown Rd. . . . . 15235
	<b>PUNXSUTAWNEY</b>
Frank Roberts & Sons . . . . .	R.D. 2 . . . . . 15767
	<b>SCRANTON</b>
Scranton Auto Ignition Co. . . . .	1133-35 Wyoming Ave. . . . . 18509
<b>TENNESSEE</b>	<b>KNOXVILLE</b>
Ace Distributors . . . . .	2103 Magnolia . . . . . 37909
	<b>MEMPHIS</b>
American Sales & Service, Inc. . . . .	3035-43 Bellbrook . . . . . 38110
<b>TEXAS</b>	<b>DALLAS</b>
Marr Brothers, Inc. . . . .	423 E. Jefferson . . . . . 75203
	<b>FORT WORTH</b>
Woodson Sales Corp. . . . .	6733 Baker Blvd. Hwy. 10 . . . . . 76118
	<b>SAN ANTONIO</b>
Engine House Inc. . . . .	8610 Botts Lane P.O. Box 17867 . . . . . 78217
<b>UTAH</b>	<b>SALT LAKE CITY</b>
Powered Products . . . . .	1661 N. Beck St. . . . . 84116
<b>VIRGINIA</b>	<b>ASHLAND</b>
RBI Corp. . . . .	101 Cedar Ridge Dr. . . . . 23005
<b>WASHINGTON</b>	<b>SEATTLE</b>
Equip. Northwest . . . . .	1410 14th Ave. . . . . 98122
<b>WISCONSIN</b>	<b>MILWAUKEE</b>
Wisconsin Magneto Inc. . . . .	4727 N. Teutonia St. . . . . 53209

### WARRANTY PARTS AND SERVICE POLICY

(0686)

The purpose of warranty is to protect the customer from defects in workmanship and materials, defects which are NOT detected at the time of manufacture. It does not provide for the unlimited and unrestricted replacement of parts. Use and maintenance are the responsibility of the customer. The manufacturer cannot assume responsibility for conditions over which it has not control. Simply put, if it's the manufacturer's fault, it's the manufacturer's responsibility; if it's the customer's fault, it's the customer's responsibility.

#### CLAIMS AGAINST THE MANUFACTURER'S WARRANTY INCLUDES:

1. Replacement of Missing Parts on new equipment.
2. Replacement of Defective Parts within the warranty period.
3. Repair of Defects within the warranty period.

All claims MUST be substantiated with the following information:

1. Model Number, Serial Number and/or Data Code of unit involved.
2. Date unit was purchased or first put into service.
3. Date of Failure.
4. Nature of Failure.