

Owner's Operating Service Instruction Manual



Model Nos.
214-200A
214-255A

- ASSEMBLY
- OPERATION
- REPAIR PARTS

VERTICAL ROTARY TILLERS

WARRANTY

For one year from date of purchase, MTD Products Inc will replace for the original purchaser, free of charge, F.O.B. factory or authorized service firm, any part or parts found to be defective in material or workmanship. All transportation charges on parts submitted for replacement under this warranty must be paid by the purchaser. This warranty does not include replacement of parts which become inoperative through misuse, excessive use, accident, neglect, improper maintenance or alterations by unauthorized persons. This warranty does not include the engine, motor, battery, battery charger or any component parts thereof. For service on these units, refer to the applicable manufacturer's warranty.

The above warranty will apply only to the original owner and will be effective only if the warranty card has been properly processed. It will not apply where the unit has been used commercially.

Warranty service is available through your local authorized service dealer or distributor. **UNDER NO CIRCUMSTANCES WILL THE RETURN OF A COMPLETE UNIT BE ACCEPTED BY THE FACTORY UNLESS PRIOR WRITTEN PERMISSION HAS BEEN EXTENDED.**

SAFETY RULES

1. Your tiller is a precision piece of power equipment. Exercise extreme caution at all times.
2. Do not attempt to start engine with the clutch control in the engaged or FORWARD position.
3. Stand clear of tines when starting engine. Never stand in front of, or work on tines while the engine is running.
4. NEVER place hands or feet in the vicinity of the tines while the engine is running.
5. Always stop engine when tiller is not in actual use.
6. Always disconnect spark plug wire during repairs or refueling operations.
7. Do not fill gas tank while engine is running. Do not spill gasoline on hot engine.

Your rotary tiller is a precision built machine designed to take the work out of gardening and other related chores. It can be used for seed bed preparation, tilling, cultivating, furrowing, composting and mulching. Like any other piece of power equipment, it requires a certain amount of care and maintenance. In return for this, it will give a maximum of service and efficiency. Read these instructions carefully before assembling or operating your tiller. Through proper care and operation, you will obtain long, efficient service and trouble free operation.

ASSEMBLY

Your rotary tiller is shipped complete in a single carton. The tines, wheels, handle and depth bar are to be assembled. This is done in the manner described below.

Tines—Mount tines on tine shaft as shown. (See page 8.) Tines must be mounted with the cutting edges facing the front. The tiller will not operate properly unless the sharpened surface of the tines enter the soil first. Secure tines in position on tine shaft with cap screws (41), and nuts (32).

Note: Dust pads (29 and 30) are provided in screw pack. These must be assembled as shown. (See Page 8.)

Wheels—Insert axle bolts (25) and washer (28) into wheel hubs. Secure with nuts (31) and washers (30) tightened only enough to allow free movement of the wheels (27). Attach wheel and axle assemblies to outside of tiller legs (29) and (32). (See page 8.)

Handle—Assemble the handle brackets (10) to the handle (2) with hex head screw (13), lockwashers (11) and hex nuts (12). DO NOT tighten. Place the handle brackets (10) in the tail piece slots. Fasten the lower hole in the handle brackets to the frame with a carriage bolt 5/16-18 x 3/4" Lg. (21), lockwasher (15) and hex nut (14). Tighten all screws and nuts. (See page 6.)

CLUTCH CONTROL LEVER ASSEMBLY

Lockout Lever—Assemble in this order: rubber washer (44), steel washer (43), lockout rod (45) (rod bracket to the front), steel washer (43) and lock nut (42). Tighten until rubber washer compresses slightly. (See page 6.)

Clutch Control Assembly—Screw the ferrule (39) on the threaded end of the lock out rod (40) until about 1/2" of the threads show. Insert the ferrule through the control lever (38), fasten with flat washer (37) and hair pin cotter (36). Put the lockout handle in the neutral position. Insert the lockout rod in the bracket on the lockout lever and secure with a hairpin cotter (36) through the center of the bracket. Adjust the ferrule so both belts are slack when the lockout lever is in the neutral position. (See page 6.)

Grips—Assemble grips (1) to handle bars.

CHECK LIST BEFORE OPERATION

1. Check tiller tines for proper installation. With throttle lever set on STOP position and the clutch control handle set in FORWARD position, slowly crank engine to determine direction of tine rotation. Be sure all tines are mounted so the sharpened edges enter the soil first.
2. Check all nuts and bolts for proper tightness. This is especially important during the initial operation period. Make the same check periodically thereafter.
3. Check gear case for proper lubricant level. With tiller on a level surface, lubricant level should be up to the front pipe plug opening. This can be checked by removing front pipe plug. Maintain correct lubricant level with Mobilube SAE 140 Gear Oil or equivalent. The gear case holds five (5) ounces of lubricant.
4. Check fuel tank. Clean, fresh, regular gasoline should be used at all times.
5. Check engine crankcase for proper oil level. The engine is shipped without oil in the crankcase. Be sure to fill crankcase before starting engine. Be sure crankcase is FULL.

STARTING YOUR TILLER

1. Be sure clutch control handle is in NEUTRAL position.
2. Move throttle lever to START position (to the left).
3. After cranking the engine several times or as soon as the engine fires, move the throttle lever to RUN position.
4. Adjust throttle lever for desired operating speed.
5. To stop engine, move throttle lever to the left (STOP position). Keep throttle lever in STOP position at all times when tiller is not in use.

NOTE: A brief break-in period is essential to insure maximum engine life. This consists of running the engine at half speed for a period of time required to use one tank of gasoline. This is necessary on the initial run only. It is also recommended that the oil be changed after first five (5) hours of operation. This allows for the removal of impurities which may have accumulated during the break-in period. Subsequent oil changes should be made as stated in the engine manual. Always check oil before using your tiller. Be sure crankcase is full.

OPERATING INSTRUCTIONS

For your own convenience and safety, observe all safety suggestions shown in this manual. Your tiller is not a toy, it is a precision piece of power equipment. Treat it as such.

It is important to recognize the fact that the forward and penetrating action of the rotary tiller is obtained from the rotating action of the tines in the soil. The depth bar acts as a brake for the tiller and controls the depth and speed at which the machine will operate. By lowering the setting of the depth bar, the forward speed of the machine is reduced and the working depth of the tines is increased. Raising the setting of the depth bar increases the forward speed and reduces the working depth. When soil conditions are severe and several passes must be made over a certain area, the depth bar setting should be lowered each time a pass is made. Further control of tilling depth and travel speed can be obtained by variation of pressure on the handles. A downward pressure on the handles will increase the working depth and reduce the forward speed.

An upward pressure on the handles will reduce the working depth and increase the forward speed. The type of soil and working conditions will determine the actual setting of the depth bar and the handle pressure required.

1. Tine engagement and forward travel is achieved by moving the clutch control handle to FORWARD position. Tine rotation and forward motion are stopped by moving the clutch control handle to NEUTRAL position. Reverse tine action and reverse travel motion can be maintained by HOLDING the clutch control handle in REVERSE position. Releasing the handle stops reverse operation automatically.
2. The throttle lever adjusts the engine speed. It also gives fingertip control of the carburetor and magneto stop switch. With the throttle lever pushed completely to the left, the carburetor is in START position. Moving the lever right slightly, adjusts the engine speed to FAST. Moving the lever further to the right reduces the engine speed to SLOW. When the lever is moved completely to the right the magneto stop switch grounds out the spark and stops the engine.
3. With the depth bar raised out of operation, self-propelled transporting of the tiller is easily achieved. With no pressure on the handles and the throttle lever set for SLOW engine speed, move the clutch control handle to the FORWARD position and let the tiller gently propel itself.

ADJUSTMENTS

Belts—Belt slack is taken up by a spring loaded idler pulley. Because of this, belt adjustment is not required.

Clutch—No adjustment in clutch linkage is required. This is done automatically by the spring loaded idler.

NOTE: Belt and clutch adjustments can be made with the adjustable control rod.

Throttle—If adjustment becomes necessary, the throttle control wire assembly can be reset as follows:

1. Loosen, but do not remove, screw securing throttle control wire assembly at engine.
2. Move throttle control knob to STOP position.
3. Move lever, to which control wire is fastened at engine, to CLOSE position and retighten screw to secure throttle control wire assembly.

Handles—The position of the handles may be adjusted by removing and moving carriage bolts in the lower mounting holes. Adjustment should be made for the most convenient operating height.

Wheels—Wheel positions may be varied to give further adjustment of handle height. Various wheel positions also give variations of the leverage and weight distribution over the tines. Wheels should be set to suit the local soil conditions and the operator's convenience.

Tines—The standard width of cut is 26". Because of the various types of work to which the tiller may be put, variation in the tilling widths may be necessary. This can be accomplished in a number of ways.

1. Standard tine arrangement ----- 26"
2. Remove outer tine assemblies (complete) -- 12"
3. Remove outer tines from outer tine assemblies. Tines may be interchanged with opposite sides ----- 20"
4. Add tine extensions to standard arrangement ----- 40"

NOTE: When adjusting tines, be sure the cutting edges enter the soil first.

MAINTENANCE AND LUBRICATION

Engine—Service engine in accordance with the engine manufacturer's owner's guide.

NOTE: To drain oil, remove oil filler plug and tip tiller on its side. Drain oil while the engine is warm. See engine manual for filling instructions.

Gear Case— Proper lubricant level should be up to the front pipe plug. Check with tiller on a level surface. Add lubricant through vented pipe plug hole. Add enough to bring level up to front pipe plug hole. Use Mobilube SAE 140 Gear Oil or equivalent. Gear case should be maintained with five (5) ounces of lubricant. Lubricate the upper bushing in the gear case with a small amount of grease. Do not over lubricate as any excess will enter the gear case proper. Use a high pressure gun grease.

Throttle—Periodically lubricate throttle control lever and throttle control wire assembly with a few drops of light oil (SAE 10 or 20) for ease of operation.

Belts—Access to V belt and pulley assemblies is accomplished by removing the engine and engine bed as described below.

1. Place clutch control handle into NEUTRAL position.

2. Remove four cap screws which secure engine bed to mounting plate assembly. Remove engine and engine bed. Do not kink control wire.
3. Remove front belt guard.
4. Remove upper belt from pulley assembly.
5. Place clutch control handle into FORWARD position.
6. Remove bottom belt.
7. Replace bottom belt. This must be properly mounted in the lower pulley grooves and between the belt clip and the idler pulley on the spring tensioned idler pulley assembly.
8. Place clutch control handle into NEUTRAL position.
9. Replace upper belt.
10. Remove inspection plate from engine bed.
11. Replace engine bed and engine on mounting plate assembly. Do not kink control wire. Move engine bed and engine as far forward as possible.
12. Reach through inspection hole and guide belt into position on engine pulley.
13. Check visually through inspection hole to make sure belt is inside all belt guards and that belt is properly seated on engine pulley. A flashlight will help you make this check quickly and easily.
14. Line up mounting holes and replace cap screws and lockwashers. Do not tighten cap screws until all are in place. Replace inspection plate.

REPLACING TILLER GEAR CASE OIL SEALS

1. Drain lubricant.
2. Remove tine assemblies.
3. Remove bearing cap.
4. Remove bearings, worm wheel and tine shaft. Do not remove bearing races.
5. Remove oil seals from gear case and bearing cap.
6. Remove all burrs from holes in tine shaft.

7. Dip oil seals in lubricant and then insert one in gear case and one in bearing cap.
8. Wipe tine shaft clean of filings and lubricate before assembling with bearings and worm wheel in gear case.
9. Replace bearing cap.

CAUTION

Do not damage oil seals. The open flanges face to the outside of the gear case.

10. Tighten bearing cap enough to seal 'O' rings.
11. Replace tines and add lubricant.

General—Check periodically all nuts and bolts. Loose nuts and bolts can cause permanent damage to your unit. Keep all nuts and bolts securely tightened.

Storage—The following steps should be taken to prepare your tiller for storage.

1. Clean tiller thoroughly and lubricate as described in the preceding instructions.
2. Coat tilling tines with grease to prevent rusting.
3. Prepare engine for storage in accordance with engine manufacturer's owner's guide.
4. Block tiller legs to raise tires clear of floor. Be sure tiller is level.
5. Store in a dry, clean area.

ATTACHMENTS

Extension Tines—This attachment is available to increase your tilling width up to 40". Extension tines are easily installed and removed. Order under part number 294-164A.

Furrow Opener—This attachment is easily installed on the depth bar of your tiller. It can be used for either furrowing or hilling operations. These attachments are available through your local dealer.

For wide (2" x .43") depth bar, order furrow opener 294-179A.

SERVICE NOTES

DRIVE BELT SLIPS

1. Lubricate contact surface under idler pulley bracket.
2. Check idler pulley bracket mounting bolts for excessive tightness. Idler pulley brackets must be mounted securely but still must move freely.
3. Check control rod for improper assembly. If adjustment tube is attached to lower end of control rod instead of upper end, it may bind on control pivot lever and prevent full use of tension spring.
4. Check belt guards. Belt guards must clear all points of the tightened belt.
5. Check belt clips. These must not touch belt when belt is tightened.
6. Check control rod adjustment. Adjusting the adjustment tube on the control rod lengthens or shortens control linkage.
7. Belt must be mounted on engine pulley. When assembling, it is often mounted between pulley and reverse drive wheel. It also must be mounted inside the stationary belt guards.

REVERSE DRIVE

1. Reverse drive wheel should line up with its matching pulley. Check mounting bolt in engine pulley for proper tightness.
2. Matching pulley for reverse drive wheel must be assembled as shown on diagram. The deeper groove matches the reverse drive wheel. The shallow groove matches the "V" belt.
3. Belt guards and belt clips must not touch the tightened belt.
4. Reverse idler bracket must move freely. Check mounting bolts for excessive tightness. Lubricate contact surface under idler bracket.
5. Reverse should operate only when control handle assembly is held in REVERSE position. Adjust control rod for proper operating position.

NOTE: If belts are excessively stretched, replacement will be necessary.

214-200A

214-255A

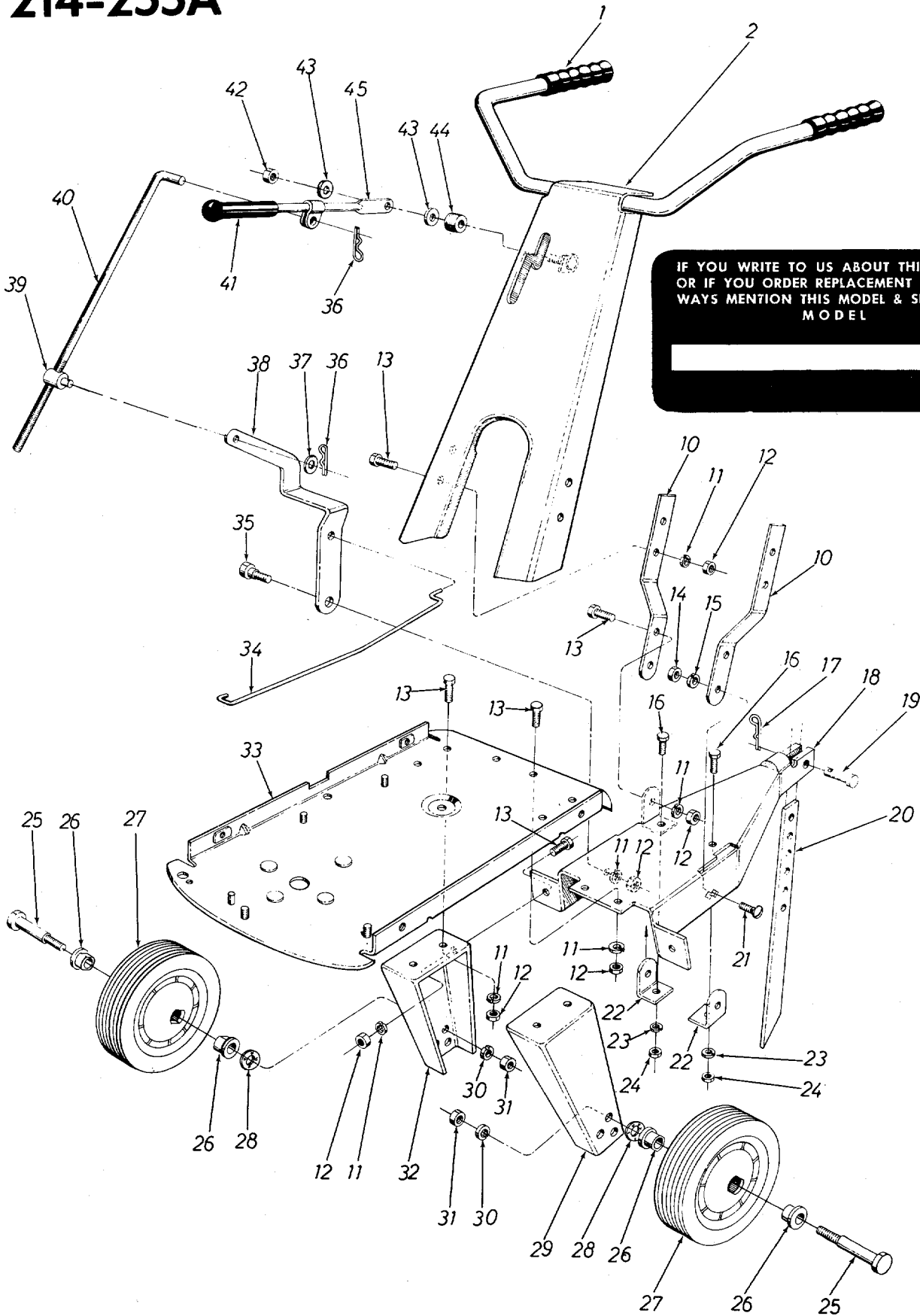

IF YOU WRITE TO US ABOUT THIS ARTICLE
OR IF YOU ORDER REPLACEMENT PARTS AL-
WAYS MENTION THIS MODEL & SERIAL NO
MODEL

PARTS LIST FOR MODELS 214-200A AND 214-255A

REF. NO.	PART NO.	COLOR CODE	DESCRIPTION	NEW PART	REF. NO.	PART NO.	COLOR CODE	DESCRIPTION	NEW PART
1	1166		Grip—Black		27	734-584		Wheel Ass'y. 10.0 x 1.75	N
2	4624—474		Handle Assembly	N	28	736-253		Belleville Wash. .505 I.D. x 1.00" O.D.	N
10	4386—474		Handle Mount Brackets						
11	736-169		L-Wash. 3/8" Scr.*		29	4109—474		Leg—Left Hand	
12	712-798		Hex Nut 3/8-16 Thd.*		30	736-921		L-Wash. 1/2" Scr.*	
13	710-253		Hex Scr. 3/8-16 x 1.00" Lg.*		31	712-206		Hex Nut 1/2-13 Thd.*	
14	712-267		Hex Nut 5/16-18 Thd.*		32	4110—474		Leg—Right Hand	
15	736-119		L-Wash. 5/16" Scr.*		33	4107—474		Mounting Plate Ass'y.	
16	710-118		Hex Scr. 5/16-18 x .75" Lg.*		34	4198		Lower Control Rod	
17	732-194		Spring Pin		35	738-183		Shoulder Scr. .500" Dia. x .215	
18	4329—474		Tail Piece Ass'y.		36	714-115		Cotter Pin 1/8" Dia. x 1.00" Lg.*	
19	711-231		Clevis Pin .500" Dia.		37	736-204		Fl-Wash. .344" I.D. x .62 O.D.	
20	4328—474		Depth Bar		38	4619		Control Pivot Lever	N
21	710-451		Carriage Bolt 5/16-18 x .75" Lg.*		39	711-392		Adjustment Ferrule	
22	4124—474		Handle Mount Brkts.		40	711-414		Control Rod	
23	736-119		L-Wash. 5/16" Scr.*		41	720-143		Grip—Black	
24	712-267		Hex Nut 5/16-18 Thd.*		42	712-158		Hex Center L-Nut 5/16-18 Thd.	
25	738-240		Shoulder Scr. .625" Dia. x 2.75	N	43	736-195		Fl-Wash. .344 I.D. x .88 O.D.	
26	748-145		Flange Brg. with Flats .631 I.D.		44	735-126		Rubber Wash. .33 I.D. x .87 O.D.	
					45	4392		Clutch Lever Ass'y.	

* For faster service, obtain standard nuts, bolts, and washers locally. If these items cannot be obtained locally, order by part number and size as shown on parts list.

(474—Citrus) *When ordering parts if color or finish is important, use the appropriate color code shown at left. (e.g. Citrus finish—4624 (474)).*

NOTE: This instruction manual covers various models and all accessories shown do not necessarily apply to your model tiller.

The engine is not under warranty by the tiller manufacturer. If repairs or service is needed on the engine, please contact your nearest authorized engine service outlet. Check the "Yellow Pages" of your telephone book under "Engines-Gasoline."

Find us fast in the



214-200A 214-255A

IF YOU WRITE TO US ABOUT THIS ARTICLE
OR IF YOU ORDER REPLACEMENT PARTS AL-
WAYS MENTION THIS MODEL & SERIAL NO
MODEL

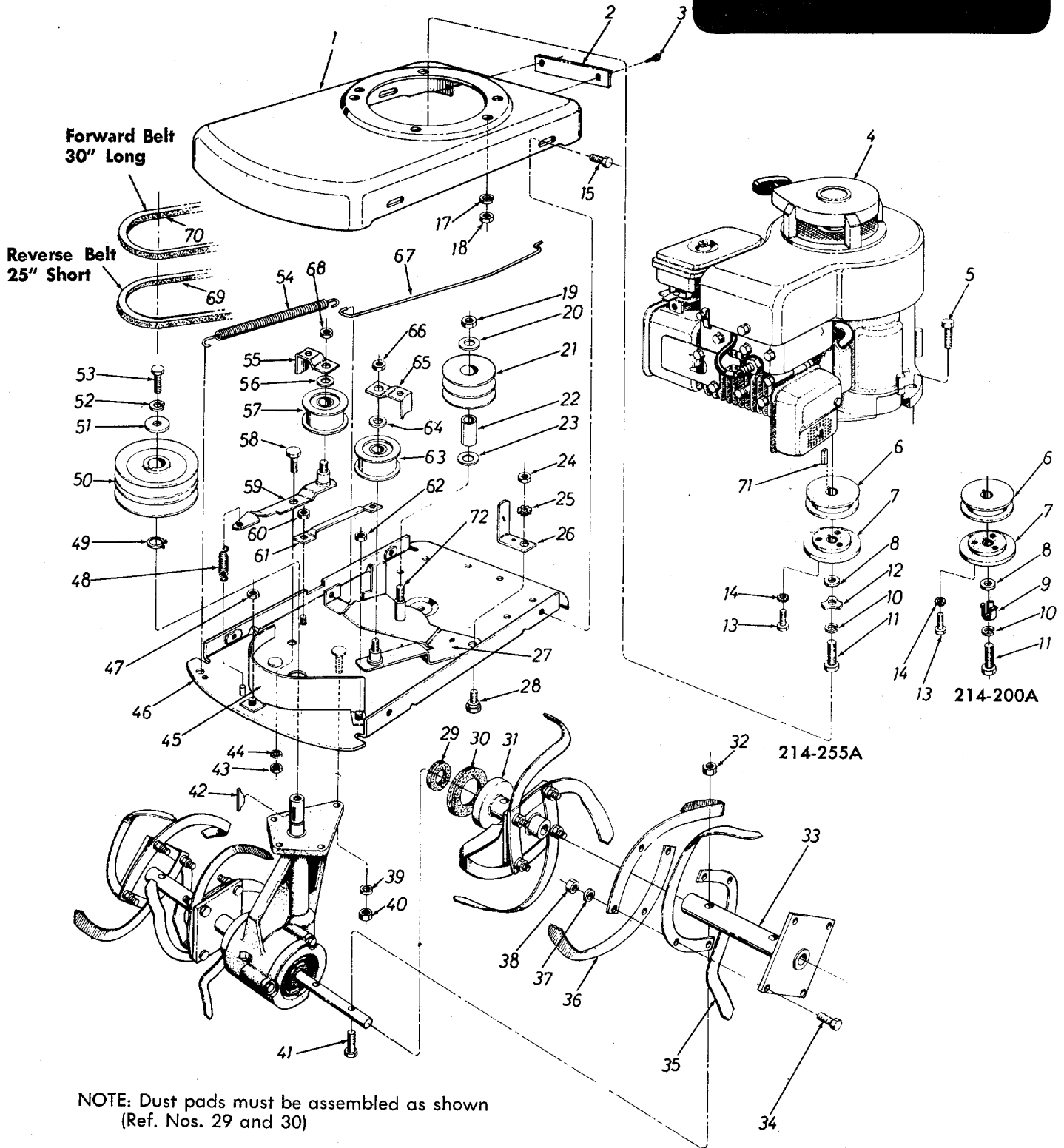

NOTE: Dust pads must be assembled as shown
(Ref. Nos. 29 and 30)

Inner Tine Assembly - R.H. - Complete 901-4288	Optional Tine Extension Order Part No. 294-164A
Inner Tine Assembly - L.H. - Complete 901-4287	
Outer Tine Assembly - R.H. - Complete 901-4290	
Outer Tine Assembly - L.H. - Complete 901-4289	

PARTS LIST FOR MODELS 214-200A AND 214-255A

REF. NO.	PART NO.	COLOR CODE	DESCRIPTION	NEW PART	REF. NO.	PART NO.	COLOR CODE	DESCRIPTION	NEW PART
1	4258—474		Engine Bed		38	712-241		Hex Nut 3/8-24 Thd.*	
2	4126		Inspection Plate		39	736-169		L-Wash. 3/8" Scr.*	
3	710-128		Hex F-Tapp Scr. #10-32 x .50" Lg.*		40	712-798		Hex Nut 3/8-16 Thd.*	
4	—		Engine		41	710-459		Hex Scr. 3/8-24 x 1.50" Lg. H.T.	
5	710-158		Hex Scr. 5/16-24 x 1.25" Lg.*		42	714-126		#9 Hi-Pro Key 3/16 x 3/4" Dia.	
6	756-105		Sheave 2.5" x .50		43	712-798		Hex Nut 3/8-16 Thd.*	
7	717-120		Friction Drive Wheel		44	736-169		L-Wash. 3/8" Scr.*	
8	736-117		Fl-Wash. .385" I.D. x .62 O.D.		45	4197		Belt Guard	
9	4259		Engine Shaft Spacer (214-200A)		46	4107—474		Mounting Plate Ass'y.	
10	736-169		L-Wash. 3/8" Scr.*		47	712-107		Hex Cent. L-Nut 1/4-20 Thd.	
11	710-152		Hex Scr. 3/8-24 x 1.00" Lg.*		48	732-250		Spring	
12	4260		Wash. Shaft Spacer (214-255A)		49	716-119		Snap Ring 3/4" Dia. Shaft	
13	710-185		Soc. Hd. Scr. #10-32 x 1.00" Lg.		50	756-197		Pulley—Double Groove 4.50" O.D.	
14	736-147		Extern. L-Wash. #10 Scr.		51	736-231		Fl-Wash. .344 x 1.125	
15	710-259		Hex Sems Scr. 5/16-18 x .62" Lg.*		52	736-119		L-Wash. 5/16" Scr.*	
17	736-119		L-Wash. 5/16" Scr.*		53	710-118		Hex Scr. 5/16-18 x .75" Lg.*	
18	712-123		Hex Nut 5/16-24 Thd.*		54	732-233		Spring Extension .62 O.D. x 4.94 Lg.	
19	712-116		Hex Cent. L-Nut 3/8-24 Thd.		55	7353		Belt Clip	
20	736-300		Fl-Wash. .385" I.D. x .87 O.D.		56	736-300		Fl-Wash. .385" I.D. x .870" O.D.	
21	756-112		Reverse Pulley		57	756-370		Idler Bearing Ass'y.	
22	748-123		Sleeve Bearing		58	738-183		Shoulder Scr. .500" Dia. x .215	
23	736-100		Fl-Wash. .500 I.D. x 1.25 O.D.		59	4202		Idler Bracket	
24	712-798		Hex Nut 3/8-16 Thd.*		60	712-107		Hex Cent. L-Nut 1/4-20 Thd.	
25	736-148		Ext. L-Wash. 3/8" Scr.*		61	4196		Hold Down Clamp	
26	4204		Belt Pusher		62	712-107		Hex Cent. L-Nut 1/4-20 Thd.	
27	4200		Reverse Idler Brkt. Ass'y.		63	756-370		Idler Bearing Ass'y.	
28	738-183		Shoulder Scr. .500" Dia. x .215		64	736-300		Fl-Wash. .385" I.D. x .870" O.D.	
29	721-120		Foam Seal 1.25" I.D. x 2.12" O.D.		65	7353		Belt Clip	
30	721-121		Foam Seal 2.25" I.D. x 2.94" O.D.		66	712-158		Hex Cent. L-Nut 5/16-18 Thd.	
31	4138		Inner Tine Adapter Ass'y.		67	4198		Lower Control Rod	
32	712-116		Hex Center L-Nut 3/8-24 Thd.		68	712-158		Hex Cent. L-Nut 5/16-18 Thd.	
33	4134		Outer Tine Adapter Ass'y.		69	754-106		V-Belt 1/2" x 25" Lg. (Reverse Belt)	
34	710-191		Hex Scr. 3/8-24 x 1.25" Lg.*		70	754-107		V-Belt 1/2" x 30" Lg. (Forward Belt)	
35	742-107		Tine 14"—Left Hand		71	714-122		Sq. Key 3/16 x 3/16 x .75" Lg.	
36	742-108		Tine 14"—Right Hand		72	738-146		Shoulder Scr. .500" Dia. x 1.350	
37	736-169		L-Wash. 3/8" Scr.*		73	4356		Reverse Pulley Ass'y. (Includes Ref. Nos. 6, 7, 13 and 14)	

* For faster service, obtain standard nuts, bolts, and washers locally. If these items cannot be obtained locally, order by part number and size as shown on parts list.

(474—Citrus) *When ordering parts if color or finish is important, use the appropriate color code shown at left. (e.g. Citrus finish—4624 (474).*

NOTE: This instruction manual covers various models and all accessories shown do not necessarily apply to your model tiller.

The tiller is not under warranty by the tiller manufacturer. If repairs or service is needed on the engine, please contact your nearest authorized engine service outlet. Check the "Yellow Pages" of your telephone book under "Engines-Gasoline."

Find us fast in the



GEAR CASE ASSEMBLY 4500

Maintain with five (5) ounces of lubricant.

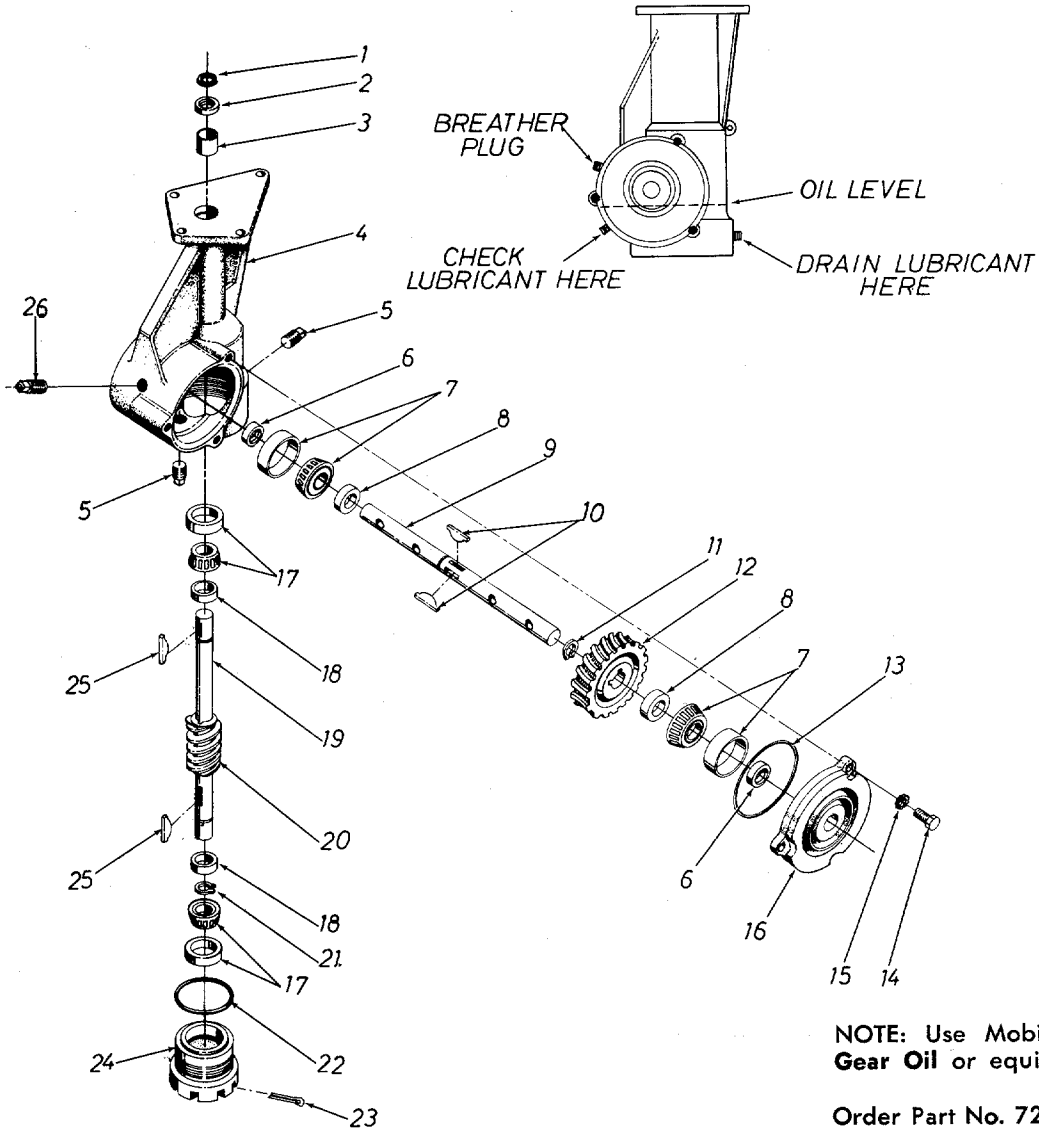

NOTE: Use Mobilube **SAE 140 Gear Oil** or equivalent.

Order Part No. 727-112 SAE 140 Gear Oil.

PARTS LIST FOR GEAR CASE ASSEMBLY 4500

REF. NO.	PART NO.	COLOR CODE	DESCRIPTION	NEW PART	REF. NO.	PART NO.	COLOR CODE	DESCRIPTION	NEW PART
1	716-119		Snap Ring 3/4" Dia. Shaft		14	710-371		Hex Scr. 5/16-18 x .88" Lg.	
2	721-100		Oil Seal 3/4" Shaft		15	736-119		L-Wash. 5/16" Scr.*	
3	748-106		Sleeve Bearing .752" I.D.		16	717-227		Bearing Cap—Bolton Type	
4	717-226		Gear Case		17	741-107		Roller Bearing 3/4" Bore	
5	737-103		Sq. Hd. Pipe Plug 3/8" Thd.		18	711-469		Spacer .755" I.D. x 1.265" O.D.	
6	721-102		Oil Seal Double Lip 1" Shaft		19	738-171		Worm Shaft	
7	741-108		Roller Bearing 1" Bore		20	717-167		Worm	
8	711-131		Spacer 1.005" I.D. x 1.390" O.D.		21	716-101		Snap Ring for .750" Dia. Shaft	
9	711-133		Tine Shaft		22	735-100		O-Ring 2.12 x 2.38	
10	714-103		#91 Woodruff Key 1/4" x 3/4" Dia.		23	714-474		Cotter Pin 1/8" Dia. x .75" Lg.*	
11	716-102		Snap Ring for 1.00" Dia. Shaft		24	10538		Bearing Adjustment Cap	
12	717-105		Worm Wheel		25	714-126		#9 Hi-Pro Key 3/16 x 3/4" Dia.	
13	735-101		O-Ring 3.62 x 3.88		26	737-102		Sq. Hd. Pipe Plug with Vent 3/8" Thd.	

*For faster service, obtain standard nuts, bolts and washers locally. If these items cannot be obtained locally, order by part number and size, as shown on parts list.

TILLER DRIVE MECHANISM

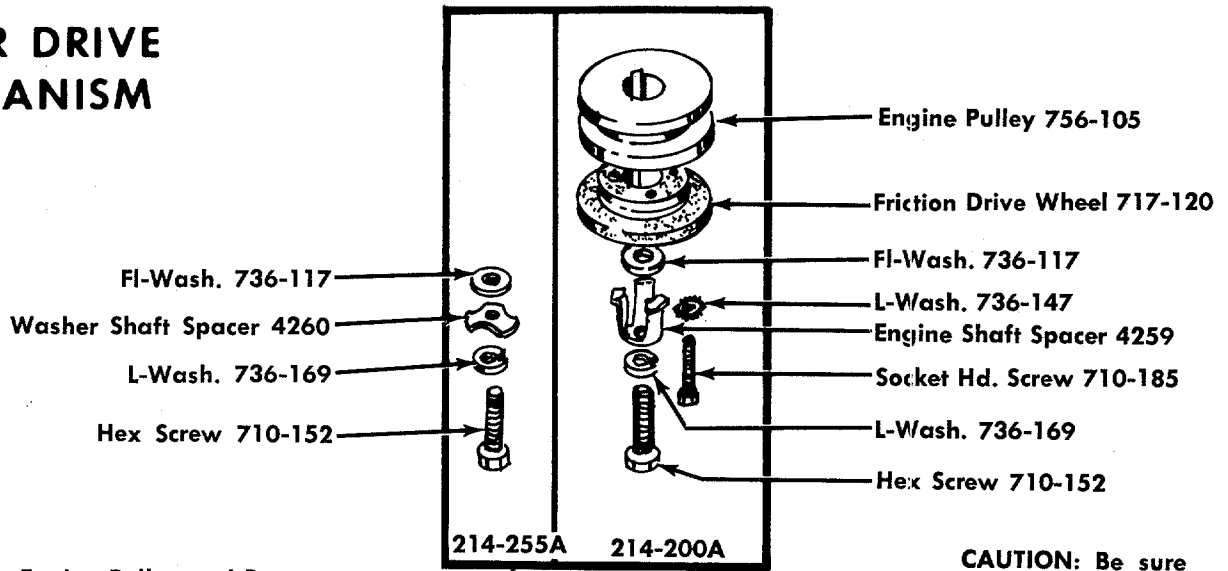

Engine Pulley and Reverse Drive Wheel Ass'y.

CAUTION: Be sure belt is inside belt pushers.

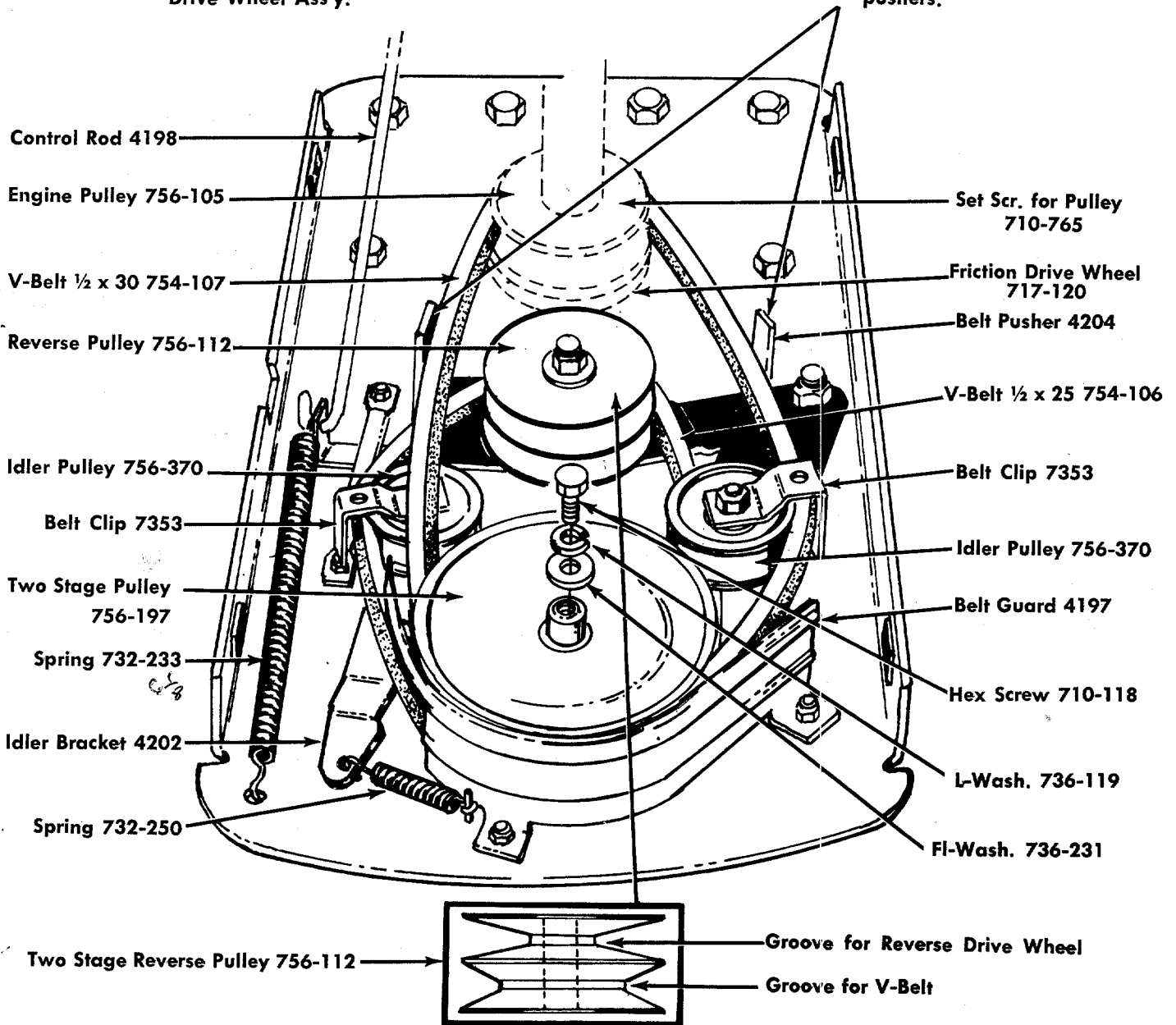

PARTS INFORMATION

DEFECTIVE OR MISSING PARTS must be reported to the factory immediately. Such claims must include your model number and date of purchase.

POWER EQUIPMENT PARTS AND SERVICE

Parts and service for all MTD manufactured power equipment are available through the authorized service firms listed below. All orders should specify the model number of your unit, parts numbers, description of parts and the quantity of each part required.

A 1 Engine & Mower Co.
327 East 9th Street
Salt Lake City, Utah 84102

American Electric Ignition Co.
124 N. W. 8th Street
Oklahoma City, Oklahoma 73102

Auto Electric & Carburetor Co.
2525 4th Avenue, S.
P. O. Box 1948
Birmingham, Alabama 35233

Automotive Equipment Service Co.
3117 Holmes Street
Kansas City, Missouri 64109

Bailey's Rebuild Inc.
1325 E. Madison Street
Seattle Washington 98102

Bleckie, Inc.
7900 Lorain Avenue
Cleveland, Ohio 44102

Brown Equipment Distributor Inc.
110 Beech Street
Corydon, Indiana 47112

Bullard Supply
2409 Commerce Street
Houston, Texas 77003

Carl A. Anderson Co.
623 S. 16th Street
Omaha, Nebraska 68102

Catto & Putty, Inc.
P. O. Box 2408
510 Soledad Street
San Antonio, Texas 78205

Center Supply Company
6867 New Hampshire Avenue
Takoma Park, Maryland 20012

Dixie Sales Company
P. O. Box 1408
327 Battleground Avenue
Greensboro, North Carolina 27402

East Point Cycle & Key Shop
1617 Whiteway
East Point, Georgia 30044

Gamble Distributors
West End Avenue
Carthage, New York 13619

Garden Equipment Co., Inc.
6600 Cherry Avenue
Long Beach, California 90805

Gardenville Supply, Inc.
Pipersville, Pennsylvania 18947

Henry W. O'Neil & Assoc., Inc.
410 North Goodman Street
Rochester, New York 14609

Henzler, Inc.
2015 Lemay Ferry Road
St. Louis, Missouri 63125

Kenton Supply
8216 North Denver Avenue
Portland, Oregon 97217

Kimber's Inc.
115 W. Geddes St.
Syracuse, New York 13204

The Lawnmower Shop
1340 El Camino Real
San Carlos, California 94070

Marr Brothers
423 E. Jefferson
Dallas, Texas 75203

Mathews Auto Electric Co.
420 East 2nd Street
Tulsa Oklahoma 74120

McClure Lawn & Garden Supply
1114 Lexington Avenue
Mansfield, Ohio 44907

Memphis Cycle & Supply Co.
421 Monroe Avenue
Memphis Tennessee 38103

Morton B. Collins Co.
300 Birnie Avenue
Springfield, Massachusetts 01107

Moz-All of Florida, Inc.
365 Greco Avenue
Coral Gables, Florida 33146

National Central, Div. of Joe Sterling, Inc.
Drawer "D" 687 Seville Rd.
Wadsworth, Ohio 44281

Parts & Sales Inc.
2101 Industrial Pkwy.
Elkhart, Indiana 46514

Power Equipment Distributor
36463 So. Gratiot Avenue
Mt. Clemens, Michigan 48043

Power Lawn & Garden Equip. Co.
2551-2571 J. F. Kennedy Road
Dubuque, Iowa 52001

Radco Distributors
2403 Market Street
P. O. Box 3216
Jacksonville, Florida 32206

Raub Supply Company
James & Mulberry Sts.
Lancaster, Pennsylvania 17604

Richmond Battery & Ignition
P. O. Box 25369 - 957 Myers St.
Richmond, Virginia 23260

Smith Hardware Company
515 N. George Street
Goldsboro, North Carolina 27530

South Denver Lawn Equip. Co.
527 West Evans
Denver, Colorado 80223

Suhren Engine
8330 Earhart Blvd.
New Orleans, Louisiana 70118

Sutton's Lawn Mower Shop
Route 4, Box 343
North Little Rock, Arkansas 72117

Warner Equipment
7520 Lyndale Avenue, So.
Minneapolis, Minnesota 55423

Woodson Sales & Service
1702 North Sylvania
Ft. Worth, Texas 76111

WARRANTY PARTS AND SERVICE POLICY

The purpose of warranty is to protect the customer from defects in workmanship and materials, defects which are NOT detected at the time of manufacture. It does not provide for the unlimited and unrestricted replacement of parts. Use and maintenance are the responsibility of the customer. The manufacturer cannot assume responsibility for conditions over which it has no control. Simply put, if it's the manufacturer's fault, it's the manufacturer's responsibility; if it's the customer's fault, it's the customer's responsibility.

CLAIMS AGAINST THE MANUFACTURER'S WARRANTY INCLUDES

1. Replacement of Missing Parts on new equipment.
2. Replacement of Defective Parts within the warranty period.
3. Repair of Defects within the warranty period.

All claims MUST be substantiated with the following information:

1. Model Number of unit involved.
2. Date unit was purchased or first put into service.
3. Date of failure.
4. Nature of failure.