

model 7090-1

24 inch 5 h.p.

snow thrower

Operating manual *and* parts list

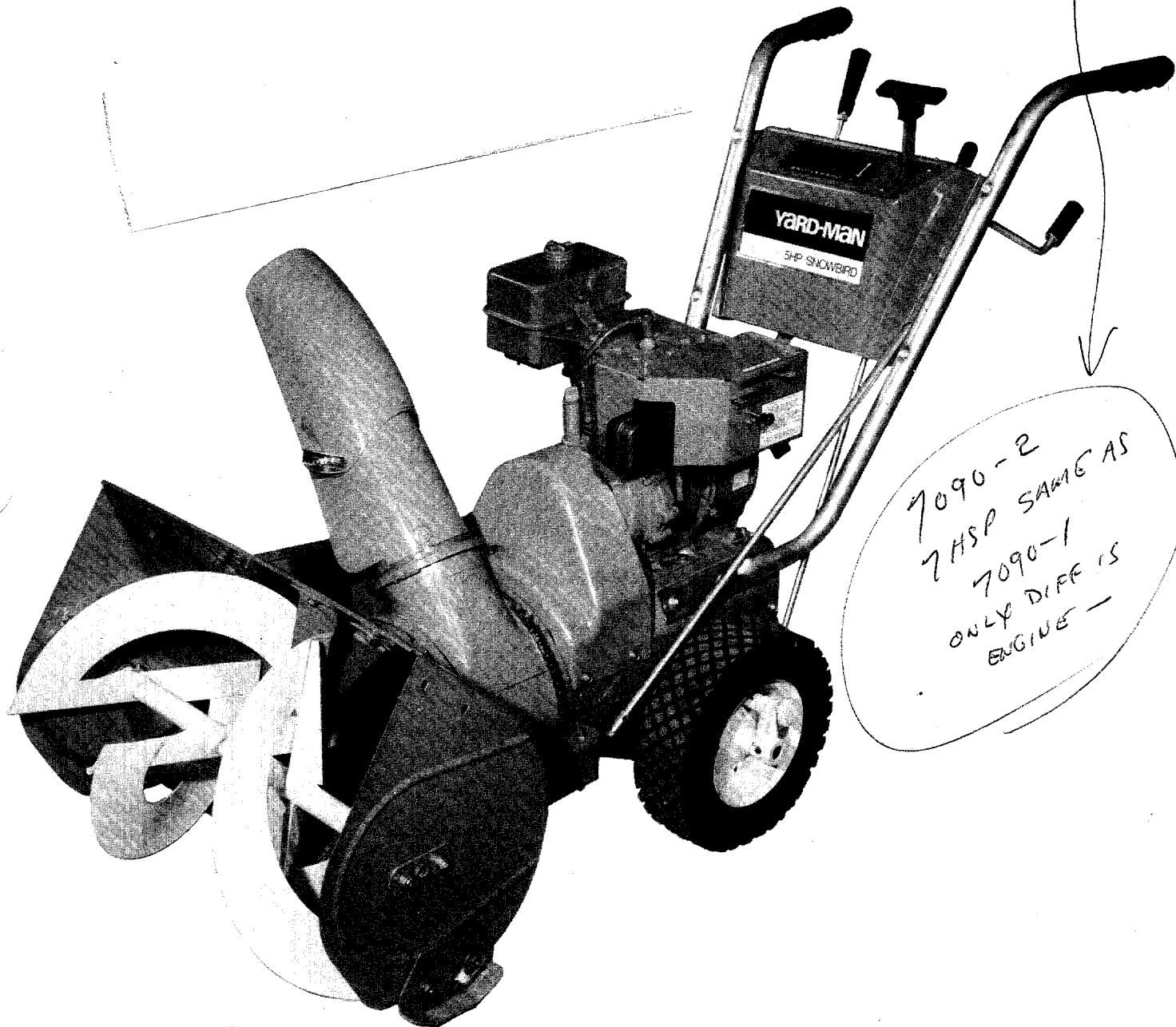

YARD-MAN

1410 West Ganson Street — Jackson, Michigan 49202

RULES FOR SAFE OPERATION

Your SNOW THROWER is a precision piece of snow throwing equipment. Engineering skill and experience have been combined to provide the ultimate in safety and efficiency. As with any type of power equipment, carelessness or error on the part of the operator can result in injury. EXERCISE EXTREME CAUTION AT ALL TIMES.

1. READ THE OWNER'S MANUAL CAREFULLY. Know the controls to operate your SNOW THROWER properly and how to quickly stop the unit.
2. BEFORE STARTING ENGINE, disengage all clutches and shift unit into neutral. Keep hands, feet and clothing away from power driven parts.
3. DISENGAGE POWER AND STOP MOTOR before cleaning discharge, removing obstacles, making adjustments, or when leaving operating position.
4. NEVER DIRECT DISCHARGE AT BYSTANDERS nor allow anyone in front of machine – debris may be hidden in the snow.
5. KEEP CHILDREN AND PETS a safe distance away.
6. DO NOT ALLOW CHILDREN TO OPERATE MACHINE nor allow adults to operate machine without proper instruction.
7. ADJUST SCOOP HEIGHT to clear gravel or crushed rock surface.
8. EXERCISE CAUTION to avoid slipping or falling, especially when operating in reverse.
9. HANDLE GASOLINE WITH CARE – it is highly flammable.
 - a. Use approved gasoline container.
 - b. Never add gasoline to a running motor. Fill tank outdoors and wipe up spilled gasoline.
 - c. Replace gasoline cap securely.
 - d. Open doors if motor is running indoors – exhaust fumes are dangerous.
10. USE A GROUNDED THREE-WIRE PLUG-IN for all units equipped with electric starting kits.
11. KEEP UNIT IN GOOD OPERATING CONDITION and keep safety devices in place.

SUGGESTIONS FOR MORE EFFICIENT, and MAINTENANCE-FREE OPERATION

GENERAL SNOW THROWING

1. Always keep area to be cleaned cleared before snowfall.
2. Always start engine with machine on level surface with master clutch disengaged. After starting, let engine warm up several minutes at slow speed before starting to remove snow. If machine is stored indoors, let engine and machine adjust to outdoor temperatures before starting to throw snow.
3. When throwing snow, run machine at full throttle for best results.
4. When in deep heavy snow, shift to slowest speed, and start at the edge of area to be cleared, discharging snow to the outside.
5. Always run engine a few minutes before storing, to dry moisture that collects inside of engine from blowing snow.

NOTE: NEVER RUN ENGINE INDOORS OR IN AN ENCLOSED AREA.

MAINTENANCE:

Your SNOW THROWER like all machines with moving parts, must receive care and maintenance. The following tips, if used, will contribute many trouble-free hours to your machine.

1. Check oil level frequently, or every 5 hours of use. When changing oil, make sure dirt and debris is cleaned from oil drain area before removing oil plug.
2. Keep fan and auger housings clean.
3. Check all nuts, bolts and screws occasionally for tightness to be sure machine is in good operating condition.
4. Should excessive vibration develop, check your fan and fan shaft immediately. Do not operate the machine with a bent fan or shaft.
5. The machine is pre-lubricated at the factory. However, lubrication with each usage will prolong life of working parts.
6. If you are going to store your SNOW THROWER for any length of time (30 days or longer) it is important that the following steps be taken.
 - a. Drain the gas tank and carburetor. Start the engine and run it until out of gas. Gasoline left in the engine will leave gum deposits in the carburetor and gas tank.
 - b. Clean engine of all foreign matter.
 - c. Lubricate cylinder by removing the sparkplug and pouring one ounce of clean lubricating oil through the sparkplug hole into the cylinder. Crank engine slowly to spread oil and replace sparkplug.
7. Should unusual vibration develop in transmission, remove rubber panel in rear cover and check rubber drive disc condition. For reference see page 11.
8. The belt tension is adjustable. The tensioning of belt should be checked every 5-10 hours of operation. Refer to adjustments section for re-setting.
9. To prevent recoil freezing, when snow thrower is to be stored outside or in sub-freezing shelter, pull recoil rope out 6" to 12" and tie knot in rope or fasten handle to keep rope from re-winding. This procedure will set inner parts in position for starting.

Just as your automobile needs professional mechanical maintenance from time to time, so does your air-cooled engine. A yearly tune-up and check by a qualified service center is recommended to avoid breakdowns and unnecessary delays during the snow throwing season.

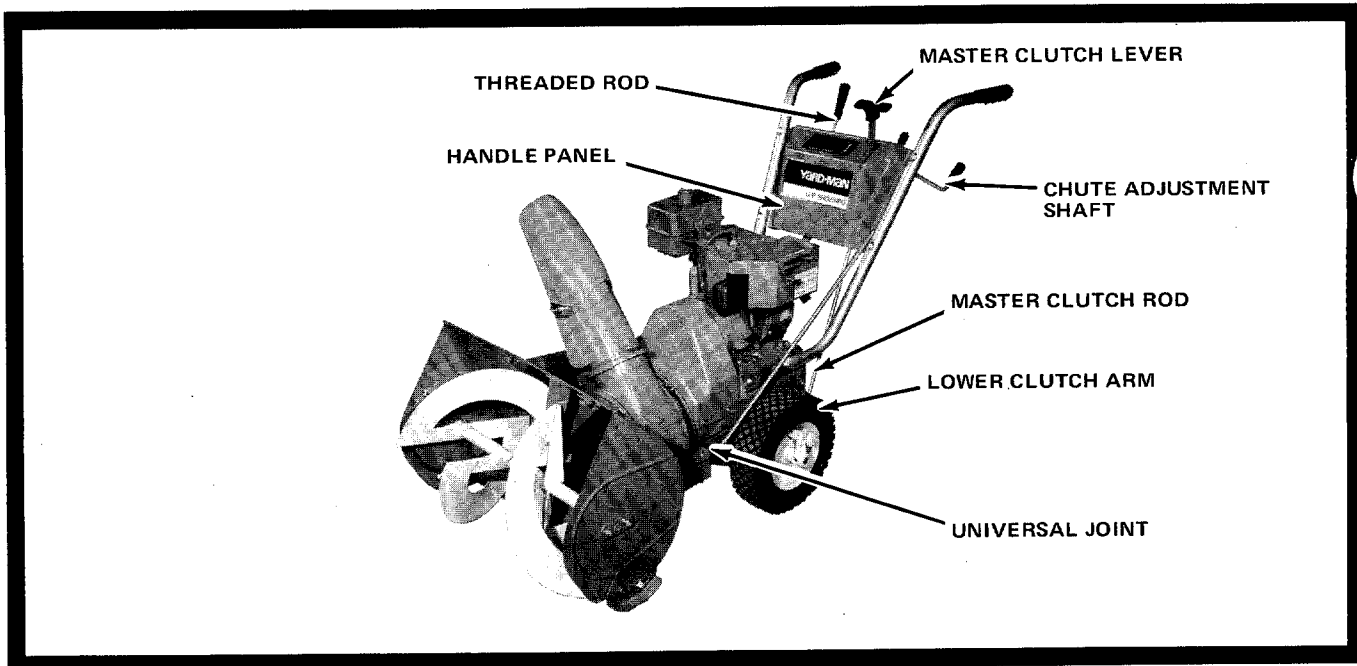

UNPACKING AND SET-UP

1. Be sure carton is right side up, cut end panels out and fold flat on floor. Remove inner pack and roll unit out of carton.
2. Assemble right and left handle tubes to the unit with bolts and flat washers. Do not tighten.
3. Assemble handle panel assembly to the under side of right and left handle tubes and secure with four slotted hex head bolts and lock nuts. Tighten all bolts on the handle assembly. Place handle grips over ends of the handle tubes.
4. Assemble chute adjustment shaft through hole in the handle panel and into universal joint located on left hand side of the frame. Align hole in universal joint with the hole in chute adjustment shaft and drive spring pin through the holes.
5. Attach master clutch rod adjusting link into the bottom hole of master clutch control located on the handle panel and attach rod end into hole in lower clutch arm. Secure with cotter pins and spread. Move master clutch lever forward to the end of the notch. To adjust, remove cotter pin from clutch lever adjustment link and thread up or down until the link is the full hole short of reaching the hole in the clutch lever. Move clutch lever back slightly to reconnect link. Replace cotter pin and spread.
6. Remove rubber shift lever panel from parts package and slip over end of shifting lever. Insert shifting lever into back of rear cover and slip small shifting rod through bushing in end of lever. Secure shift lever to mounting bracket with bolt, washer, bushing, and nut. Assemble threaded rod into end of shift lever through handle panel, locking rod in position with nut. Assemble plastic knob onto shift lever rod. Snap rubber shift lever panel into rear frame cover holes. Refer to Page 7 to make adjustment of shift lever panel notches.

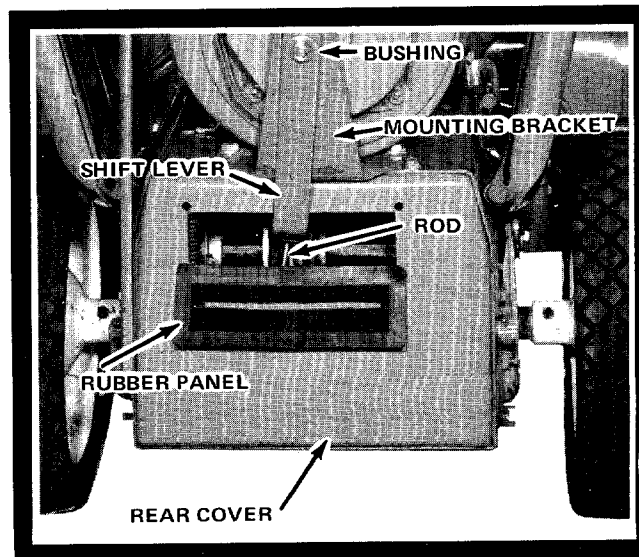
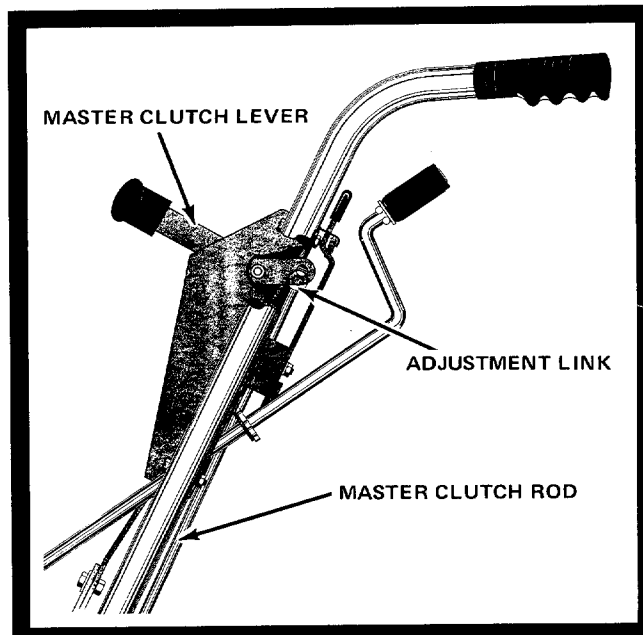

BEFORE STARTING ENGINE

1. Fill the fuel tank with fresh winter blend regular gasoline. **DO NOT MIX OIL WITH GASOLINE.** Make certain the fuel shut-off valve under the gas tank is turned on.
2. Place machine on a level surface. Remove oil fill cap and fill crankcase with good quality detergent oil.
Use MS classification SAE 5W-20 oil for operation below 40° F. Use MS classification SAE 30 oil for operation above 40° F.
3. During initial "Break-in" period, the oil should be checked often.
4. Change oil after first two (2) hours of operation and check oil level every five (5) operating hours or each time machine is used.

STARTING ENGINE

Shift the master clutch control to the Neutral position. Move the choke lever to full choke position. Move speed control lever to run position. Start the engine by pulling rapidly on the recoil starter rope. As the engine starts and begins to warm up, gradually return the choke lever to the "No Choke" position.

NOTE: Temperatures 10° F. and below use "Primer." Push primer button in and hold, pull engine slowly over compression once and release primer button. **DO NOT ATTEMPT TO START THE ENGINE WITH PRIMER BUTTON HELD IN.** (Do not use primer with 110 volt electric starter).

If the engine should fail to start, refer to your engine Instruction Manual.

STOPPING THE ENGINE

To stop the engine move the speed control lever to the stop position or close the fuel shut-off valve under the gasoline tank. The sparkplug wire may also be removed to prevent accidental starting while unattended. Always run engine a few minutes before storing to dry moisture that collects inside of engine from blowing snow.

BEFORE SNOW THROWING

1. Try your Snow Thrower machine in a large open space with engine throttle in slow position. Learn to start, stop and back-up during this trial run.
2. In rough areas, lower the adjustable skids.
3. Remove stones, wire, cans, boards, bones or other solid objects from area to be cleared.
4. Always run engine a few minutes out-doors before throwing snow, to adjust engine and machine to outside air temperature.

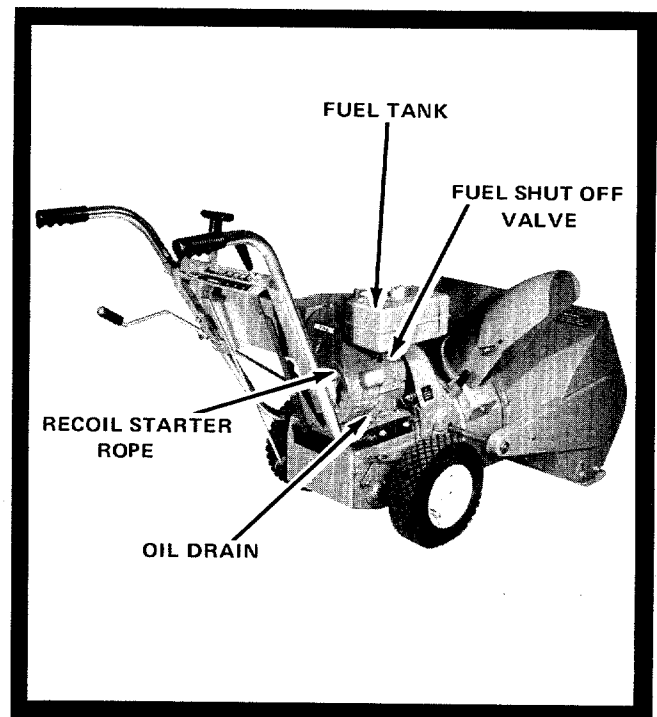
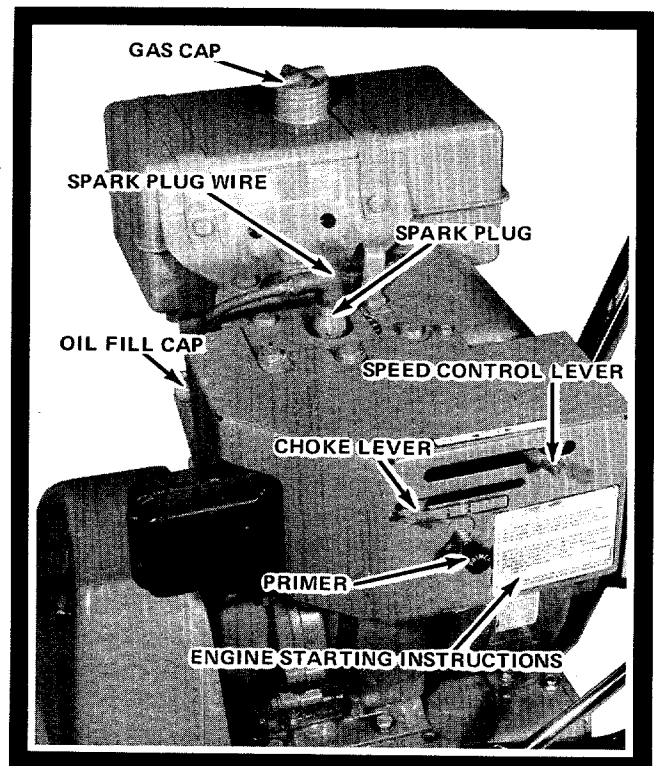

OPERATION OF CONTROLS

MASTER CLUTCH CONTROL

The master clutch control is located on handle panel and is used to engage all power. Select a forward speed or reverse with shift lever, then release master clutch control and push forward to engage drive disc, fan, reel. To disengage, pull master clutch control back and lock in notch. The master clutch control must always be in neutral position before starting engine.

FREE WHEELING

The wheel clutches are located on wheels and are used to engage or disengage power to wheels. To free the wheels for pushing, pull out on the knob and turn to lock. To provide self-propelling power to the wheels turn clutches in the opposite direction and release. The wheel clutches are spring-loaded, move unit until the clutches lock to wheels.

DEFLECTOR

The deflector may be positioned in either a vertical or a 45° position in relation to the spout as needed for proper snow deflection by loosening the two wing nuts on both sides of the deflector. NOTE: For shipping purposes the deflector is lowered off the hinging pin. Loosen the wing nuts and reposition the deflector over the pin before operating the Snow Thrower.

DISCHARGE CHUTE AND SPOUT

To rotate the discharge chute to the right or left, release chute lock lever, then rotate with chute adjustment shaft to desired position and lock. NOTE: The spout and deflector rotates automatically when rotating the discharge chute to the right and left. If it is desired to change position of the spout, lift spout lock lever on the right hand side of unit and hold while rotating the spout. Release the lever and turn spout slightly until it locks into position.

ADJUSTMENTS

NOTE: Make all adjustments with the engine turned off and wire removed from the sparkplug. (Fasten wire to cylinder head at least 1" away from sparkplug.)

DEPTH ADJUSTMENT

The adjustable skids may be set lower to prevent picking up loose stones and foreign material. Also they can be raised to allow the reel to slightly touch the ground for additional pulling power.

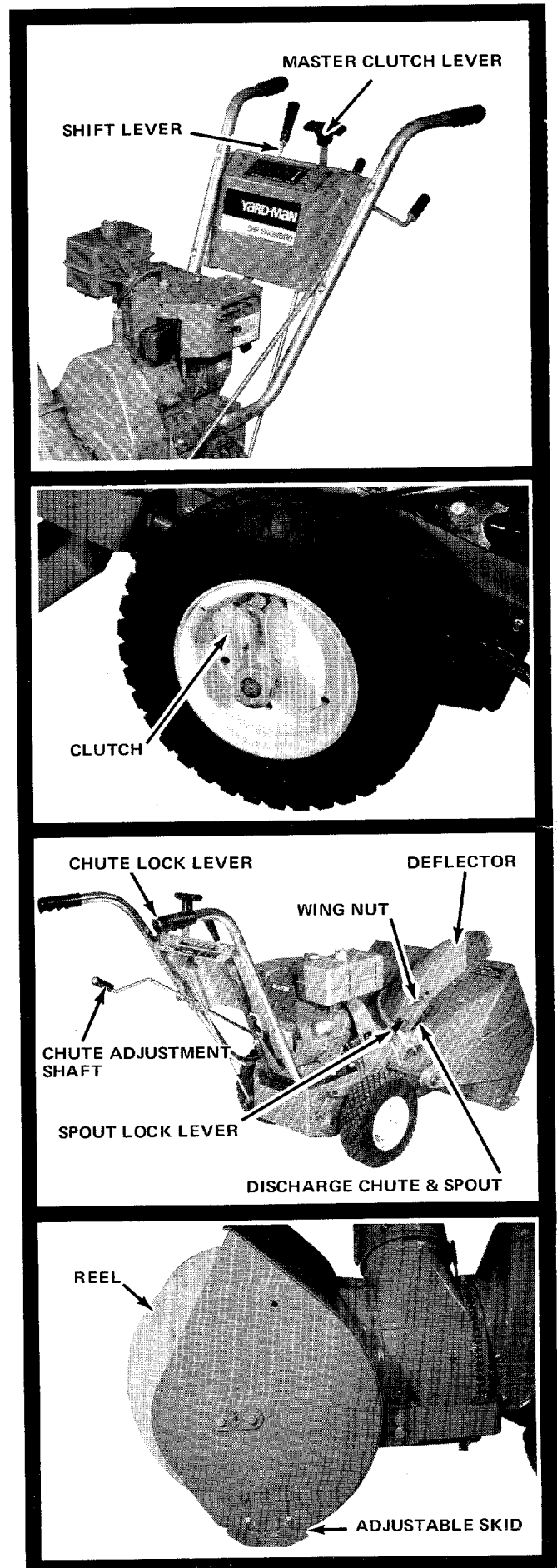

REPLACING SAFETY SHEAR BOLT

If the intake snow reel should jam causing the safety shear bolt to shear, it may be replaced with a new bolt, furnished in the parts bag, after removing the broken pieces in the shaft. **NOTE:** Always align the hole in the reel shaft and the sprocket shaft before driving out the broken bolt.

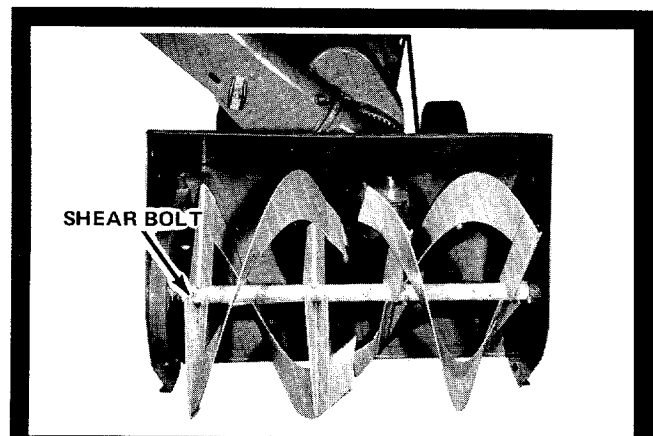

CHUTE CHAIN AND ADJUSTMENT

To tighten the chute chain, rotate the chute all the way to the left, until the adjustment bolt is accessible. Tighten the adjustment nut to tighten the chain.

CAUTION: Chain should be kept snug on chute housing.

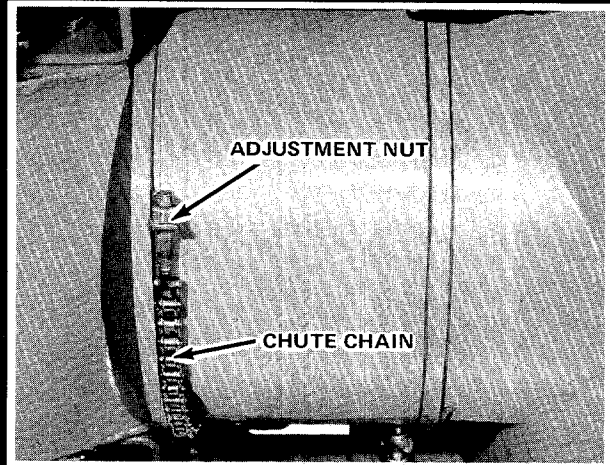

CHUTE CABLE ADJUSTMENT

Remove cable roller cover, loosen the locking bolt on top of the cable roller bracket and tighten the adjustment bolt on the side.

CAUTION: The cable should not be adjusted too tightly, adjustment should allow the spout to rotate freely. Retighten the locking bolt and replace the cable roller cover.

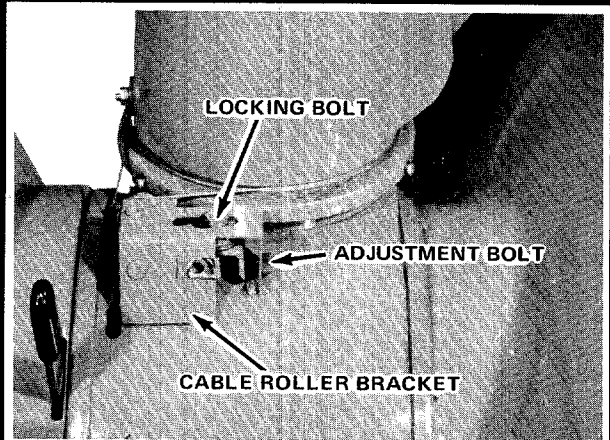

SHIFT PANEL ADJUSTMENT

To set or adjust the shift panel for correct speeds, place master clutch control in neutral position and the shift lever into the fifth speed notch. Loosen the two mounting bolts and push shift lever right as far as allowed, hold, and tighten mounting bolts. **DO NOT ATTEMPT THIS ADJUSTMENT WITH THE ENGINE RUNNING.** To check adjustment, start engine, move shift lever to first speed notch and engage master clutch control. Unit should move forward very slowly.

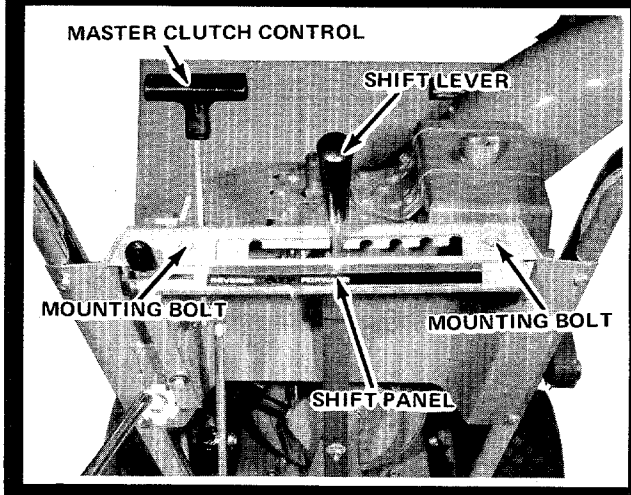

NOTE: Adjustment section continued on page 12.

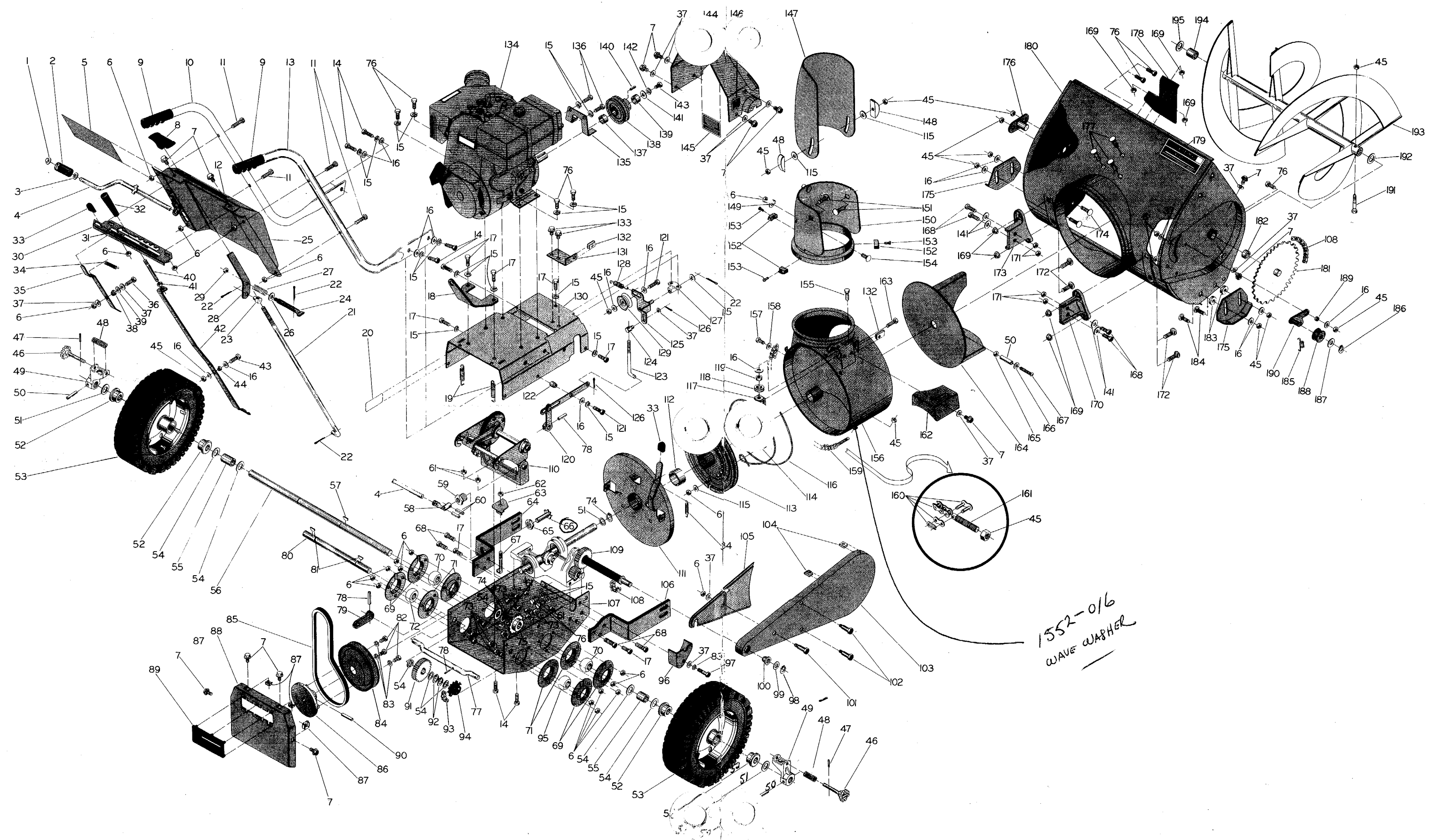

PARTS LIST

MODEL 7090-1

Your SNOW THROWER is right hand (R.H.) or left hand (L.H.) as you operate machine.

REF. NO.	PART NO.	DESCRIPTION	REF. NO.	PART NO.	DESCRIPTION
1	1539-80	Nut - Push 1/2	99	1540-138	Washer - Flat Steel 23/32 x 1-1/4 x 1/32 T.
2	1658-29-40	Roller - Crank	100	1657-65	Bushing - Step
3	41256	Washer - SAE 1/2	101	1513-113	Bolt - Shoulder 1/4-20 x 1-9/16
4	2119-49	Assembly - Chute Crank	102	1513-125	Bolt - Shoulder 1/4-20 T.
5	3616-515	Decal, - Handle Panel	103	2118-56	Assembly - Chain Cover W/Bushing
6	1538-30	Nut - Hex Lock 1/4-20 Eslok	104	42104	Nut - Speed Grip 1/4-20
7	40070	Bolt - Flanged Whizlock 1/4-20 x 1/2	105	3622-117	Cover - Chain Inside
8	2643-51-40	Knob "T"	106	3765-4	Strap - Scoop Mount R.H.
9	1710-50-40	Grip - Handle	107	2168-55	Assembly - Frame
10	4712-99	Handle - L.H.	108	1654-33	Chain - Reel W/Conn. Link #40 x 100 Pitches
11	1509-139	Bolt - Hex Head Slotted 1/4-20 x 1 - 1/2	109		See Page 11
12	1616-459	Decal - Operations	110		See Page 11
13	4712-98	Handle - R.H.	111	3150-13	Assembly - Chute Frame Disc (Complete)
14	40890	Bolt - Hex Head 5/16-18 x 1" Grade 5	112	41362	Bushing - Oil Filled 1.645/1.6425 x 1.755/1.7525 x 1-1/32
15	40149	Washer - Lock Spring Type 5/16	113	3120-70	Assembly - Cable Pulley
16	40148	Washer - Standard Wrought 5/16	114	1509-126	Bolt - Hex Head 1/4-20 x 1/2 Grade 5
17	3-79	Bolt - Hex Head 5/16-18 x 3/4	115	40156	Washer - S.A.E. 5/16
18	3609-433	Bracket - Shift lever mount	116	20266	Cable - Steel 1/16 Dia. x 86"
19	41994	Spring - Extension	117	60051	Bracket - Cable Tightener
20	1605-581	Decal - Name Plate	118	20110	Roller - Cable
21	1683-92	Rod - Clutch	119	40108	Bushing - Cable Roller
22	40035	Pin - Cotter 1/8 x 1"	120	2169-31	Assembly - Arm (Clutch Linkage)
23	21989	Link - Rod Adjustment	121	40152	Bolt - Hex Head 5/16-18 x 1-1/2
24	1683-93	Rod - Clutch Handle	122	1657-64	Bushing - Step
25	3153-36	Assembly - Handle Panel	123	1683-91	Rod - Idler Link
26	1008	Washer - SAE 3/8	124	1625-31	Link - Rod Connecting
27	1642-112	Spring - Compression	125	1169-32	Assembly - Idler Arm
28	1705-39	Lever - Clutch	126	41767	Pin - Cotter 3/32 x 3/4
29	41-028	Nut - Hex Lock 5/16-24	127	2609-440	Bracket - Idler Mount
30	3709-33	Panel - Shifting	128	1642-111	Spring - Extension
31	2616-461	Decal - Shift Panel	129	41374	Assembly - Pulley Idler
32	41226	Knob - Shifting	130	2130-11	Assembly - Engine Base
33	1674-47-40	Cap - Chute Lock	131	1609-542	Bracket - Support (Belt Cover)
34	42200	Spring - Extension	132	40115	Nut - Speed (U-Type) 1/4-20
35	2705-40	Lever - Chute Lock	133	1513-36	Bolt - Flanged Whizlock 1/4-20 x 5/8
36	1509-35	Bolt - Hex Head 1/4-20 x 5/8	134	2200-55	Engine - 5 H.P. Tecumseh
37	40892	Washer - SAE 1/4	135	2659-22	Guide - Belt Restrictor
38	1657-58	Bushing - Step	136	1509-134	Bolt - Hex Head 5/16-24 x 1/2
39	1552-9	Washer - Wave 1/4	137	1657-40	Bushing - Pulley Spacer
40	1683-94	Rod - Shift Lever Extension	138	22455	Pulley - Engine
41	42342	Nut - Hex Lock 3/8-16 Eslok	139	1657-41	Bushing - Pulley Spacer
42	2155-26	Assembly - Shifting Lever	140	1646-20	Key - Pulley
43	1509-17	Bolt - Hex Head 5/16-18 x 1"	141	40794	Washer - Standard Wrought 3/8
44	1657-67	Bushing - Spacer	142	1542-8	Washer - Lock 3/8 Spring Type
45	40153	Nut - Hex Lock (2-Way)	143	1509-105	Bolt - Hex Head 3/8-24 x 1/2
46	1643-52-41	Assembly - Knob w/Lock Pin	144	4622-119	Cover - Pulley & Belt
47	1548-14	Pin - Spring 1/8 x 1"	145	1616-458	Decal - Belt Replacement
48	1642-114	Spring - Compression	146	42235	Decal - Spout Release
49	3609-442-41	Bracket - Wheel Lock	147	21272	Deflector - Discharge
50	40052	Pin - Spring	148	20102	Nut - Wing
51	1540-137	Washer - Flat Steel 51/64 x 1-1/4 x 1/32 T.	149	40085	Washer - Cable Clamp
52	1652-122	Bushing - Flanged Wheel	150	3213-5	Assembly - Spout
53	3110-67-41	Assembly - Wheel Complete	151	40100	Bolt - Carriage Short Sq. Neck 5/16-18 x 1
54	40864	Washer - Flat Steel 51/64 x 1-1/4 x 1/16 T.	152	1704-8	Shoe - Retainer
55	1647-84	Bushing - Spacer	153	1511-44	Screw - Slotted Hex Head #6 x 3/8
56	2632-189	Shaft - Wheel Axle	154	1529-30	Bolt - Carriage 1/4-20 x 1/2
57	1646-23	Key - Woodruff	155	40496	Screw - Hex Head 5/16 x 1-1/2 Type B.
58	22222	Universal Joint	156	2102-175	Assembly - Blower Housing & Chute
59	1657-61	Bushing - Hex	157	1513-122	Screw - Self Tapping #10-32 x 3/4
60	1548-20	Pin - Spring	158	1540-145	Washer - Standard Wrought
61	42373	Nut - Hex Lock	159	1209-1	Assembly - Chute Chain
62	42180	Nut - Hex Lock (Esna #10-24)	160	1654-30	Chain W/Conn Link - #41 x 26 Pitches
63	1606-144	Plate - Chute Sprocket Cover	161	40110	Bolt - Chain Connecting
64	3765-3	Strap - Scoop Mount L.H.	162	3622-119	Cover - Cable Roller Bracket
65	41182	Nut - Hex Lock (Esna 3/4-16)	163	40495	Screw - Slotted Hex Head 5/16 x 1 Type B
66	1119-45	Assembly - Sprocket & Shaft	164	2197-5	Assembly - Fan
67	1513-115	Bolt - "J"	165	42194	Nut - Hex Lock #8-32
68	1509-136	Bolt - Hex Head 3/8-16 x 1" Grade 5 Eslok	166	42195	Washer - Flat Steel #8
69	1543-46	Washer - Flanged Retainer W/Oil Groove	167	42193	Screw - Slotted Round Head #8-32 x 1-3/4
70	41299	Bushing - Spherical 20MM	168	1509-117	Bolt - Hex Head 3/8-16 x 1-1/4 Grade 5
71	1543-47	Washer - Flanged Retainer	169	1538-22	Nut - Hex Flanged Whizlock
72	1652-115	Bushing - Spherical 3/4 Short	170	3609-438	Bracket - Scoop Mounting R. H.
73	1509-15	Bolt - Hex Head 1/4-20 x 1/2	171	42364	Nut - Hex Lock 3/8 Esna
74	1650-50	Ring - Retaining (External)	172	40160	Bolt - Carriage 5/16-18 x 3/4
75	2638-53	Sprocket - 20 T.	173	3609-439	Bracket - Scoop Mounting L.H.
76	40157	Bolt - Hex Head Whizlock 5/16-18 x 5/8	174	40160	Bolt - Carriage
77	2632-180	Shaft - Offset	175	2713-10	Ski d - Scoop
78	40790	Pin - Spring	176	1119-46	Assembly - Reel Shaft & Plate
79	1680-75	Arm - Lever (Clutch Rod)	177	40042	Bolt - Carriage 5/16-18 x 1/2
80	2632-178	Shaft - Intermediate	178	3609-423	Bracket - Snow Stop
81	42011	Key - Woodruff 3/16 x 5/8	179	2616-513	Decal - Caution
82	1509-137	Bolt - Hex Head (Self Tapping) 1/4-20 x 3/4	180	2212-9	Assembly - Scoop
83	1018	Washer - Lock Spring Type 1/4	181	2121-17	Assembly - Reel Sprocket
84	3626-91	Pulley - "V" Special 8"	182	1652-117	Bushing - Scoop End 7/8 x 1 x 3/4
85	1651-45	Belt - "V" 4L Special	183	1657-59	Bushing - Skid Spacers
86	3675-20	Disc - Friction Drive	184	41133	Bolt - Carriage 5/16-18 x 3/4
87	1539-86	Nut - Speed Grip 1/4-20	185	1642-110	Spring - Extension
88	3622-115	Cover - Rear Frame	186	1650-48	Ring - Retaining (Ext.) 1/2
89	2622-121-40	Cover - Shift Lever Panel	187	1540-118	Washer - Flat Steel 17/32 x 1-1/4 x 1/16 T.
90	40050	Pin - Spring 5/16 x 2"	188	1626-76	Pulley - Chain Idler
91	2635-74	Gear - Spur 38 T.	189	1657-60	Bushing - Chain Idler
92	40735	Ring - Retaining 3/4	190	1169-30	Assembly - Arm (Chain Idler)
93	1654-32	Chain - W/Conn. Link #41 x 36 pitches	191	1513-112	Bolt - Shear
94	2638-52	Sprocket W/Hub 15 T.	192	1540-141	Washer - Flat Steel (As Needed) 57/64 x 1-1/4 x 1/32 T.
95	1652-92	Bushing - Spherical 3/4	193	2135-50-41	Assembly - Reel W/Bushings
96	2622-118	Cover - Gear (Lower)	194	40027	Bushing - Oilite
97	1509-69	Bolt - Hex Head 1/4-20 x 1-3/4	195	40883	Washer - Flat Steel (As needed) 57/64 x 1-1/4 x 1/32 T.
98	1650-51	Ring - Retaining (External) 11/16			

TRANSMISSION

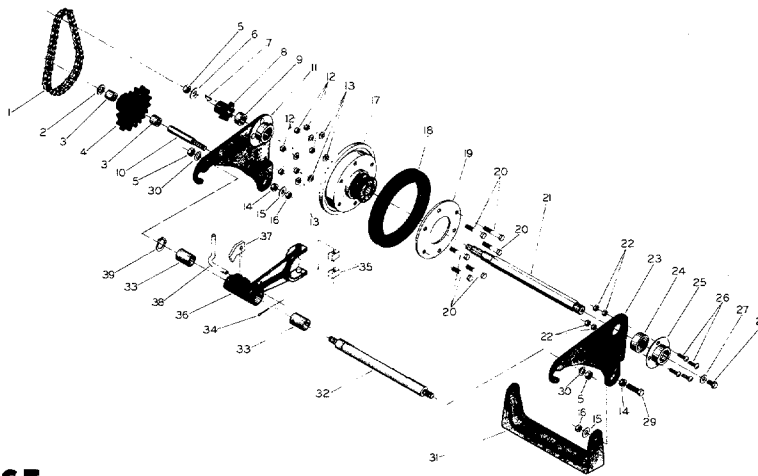

PARTS LIST

REF. NO.	PART NO.	DESCRIPTION	REF. NO.	PART NO.	DESCRIPTION
1	1654-31	Chain - W/Connecting Link No. 41 x 28 pitches	21	2632-175	Shaft - Hex
2	1624-192	Spacer - Gear Sprocket	22	42180	Nut - Hex Lock No. 10-24 Esna
3	1652-114	Bearing - Needle 7/16 x 1/2 L.	23	3606-146	Plate - Pivot R.H.
4	1149-5	Assembly - Gear & Sprocket W/Bearing (Included Ref. No. 3)	24	1652-108	Bearing - Ball Sealed
5	42342	Nut - Hex Lock 3/8-16 (Eslok)	25	1629-14	Flange - Retainer
6	1008	Washer - S.A.E. 3/8	26	1511-39	Screw - Slotted Truss Head No. 10-24 x 5/8
7	1646-24	Key - Woodruff 3/32 x 5/8	27	1540-99	Washer - Standard Wrought 1/4
8	2638-51	Sprocket - 8T.	28	40070	Bolt - Flanged Whizlock 1/4-20 x 1/2
9	1624-191	Spacer - Sprocket	29	40890	Bolt - Hex Head 5/16-18 x 1" (Grade 5) (Eslok)
10	1632-177	Shaft - Gear & Sprocket	30	1542-8	Washer - Lock Spring Type (Med) 3/8
11	2111-107	Assembly - Plate Pivot L.H.	31	2609-432	Bracket - Mount (Pivot Plate)
12	1538-30	Nut - Hex Lock 1/4-20 Eslok	32	1632-176	Shaft - Step
13	1018	Washer - Lock Spring Type (Light 1/4)	33	1657-63	Bushing - Sintered Bronze 3/4 x 7/8 x 1"
14	1657-60	Bushing - Pivot	34	40035	Pin - Cotter 1/8 x 1"
15	40148	Washer - Standard Wrought 5/16	35	1704-1	Shoe - Shifting Yoke
16	42373	Nut - Hex Lock 5/16-18 Esna	36	2147-14	Assembly - Shifting Yoke
17	3150-1	Assembly - Disc Drive Wheel W/Hub	37	1777-6	Ear - Shift Yoke Stop
18	2675-9	Ring - Rubber Drive	38	1683-90	Rod - Shifter
19	1629-15	Plate - Retainer	39	40735	Ring - Retaining 3/4
20	1509-90	Bolt - Hex Head 1/4-20 x 1-1/4			

GEAR CARRIER

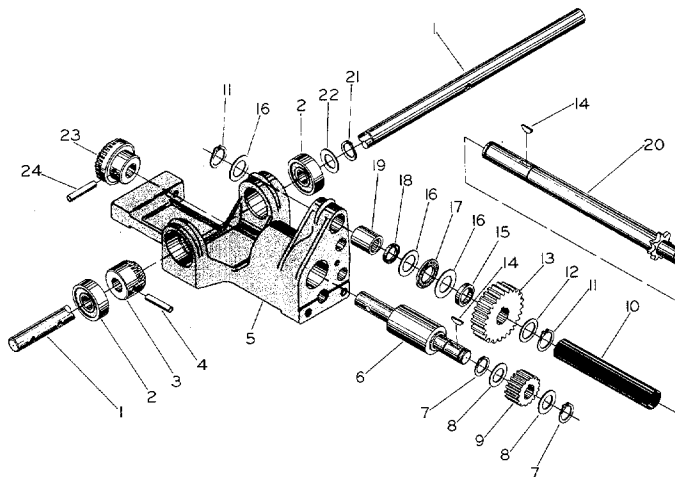

PARTS LIST

REF. NO.	PART NO.	DESCRIPTION	REF. NO.	PART NO.	DESCRIPTION
1	2632-174	Shaft - Fan 20 MM	13	2635-69	Gear - Spur 30 T.
2	1652-111	Bearing - Ball (Double Sealed) 204	14	42011	Key - Woodruff 3/16 x 5/8
3	2635-72	Gear - Bevel 18T.	15	1624-190	Spacer - Gear
4	40052	Pin - Spring 5/16-Dia. x 1-1/2	16	1543-60	Washer - Thrust
5	4609-441	Bracket - Gear Carrier	17	1652-124	Bearing - Thrust
6	1652-125	Bearing - Shaft & Integral	18	1656-13	Seal - Oil 13/16 x 1-1/16
7	40735	Ring - Retaining (External) 3/4	19	1652-113	Bearing - Roller (Needle) 13/16
8	40883	Washer - Flat Steel 25/32 x 1-1/4 x 1/32	20	2119-54	Assembly - Shaft W/Sprocket
9	2635-70	Gear - Spur 14 T.	21	1650-50	Ring - Retaining (External) 25/32
10	1624-193-40	Sleeve - Shaft Cover	22	1540-137	Washer - Flat Steel 51/64 x 1-1/4 x 1/32 T.
11	1650-49	Ring - Retaining (External) 13/16	23	2635-71	Gear - Bevel 26T.
12	1540-136	Washer - Flat Steel 27/32 x 1-1/4 x 1/32 T.	24	40220	Pin - Spring 5/16 x 1-3/4

ADJUSTMENTS (Continued from page 7)

NOTE: Make all adjustments with the engine turned off and wire removed from the sparkplug. (Fasten wire to cylinder head at least 1" away from sparkplug.)

IDLER LINKAGE ADJUSTMENT

Should the drive belt stretch sufficiently to cause the adjustment link to hang up in the bottom of the idler arm slot when the master clutch lever is in drive position, readjust as follows. To adjust, move master clutch to drive position, remove cotter pin from adjustment link, or bottom of rod, and thread link upon rod until it is not hanging up in bottom of slot and nearly centered in slot. Place link into slot, replace cotter pin, and spread.

To check the adjustment, return the master clutch lever to neutral position and pull engine recoil over to see if belt is not driving. If belt does not release, lower the adjustment link slightly below center or until belt does release in neutral. These adjustments must also be checked when belt is replaced or the idler is adjusted in the idler arm slot.

IDLER PULLEY ADJUSTMENT

For more adjustment to gain proper tension on the belt, the idler pulley can be moved in or out in the adjustment slot. Refer to idler linkage adjustments after making this adjustment.

BELT REPLACEMENT

First, remove plastic cap on spout lock lever, then remove belt cover. Unhook idler spring to release idler tension on belt. Remove belt restrictor. Remove rear cover (after shift lever is removed). This will allow one to reach in from back of unit. Remove master clutch rod from lower arm. Remove belt from engine pulley and push belt down off drive pulley. Push belt toward rear of unit around drive disc, then pull belt up between rubber drive disc and pulley disc. Push down on lower arm on left side of unit, this allows more room between rubber disc and pulley disc. Reach in from back of unit and push belt up, then pull belt out. To install new belt, reverse steps using only original equipment replacement belt No. 1651-45.

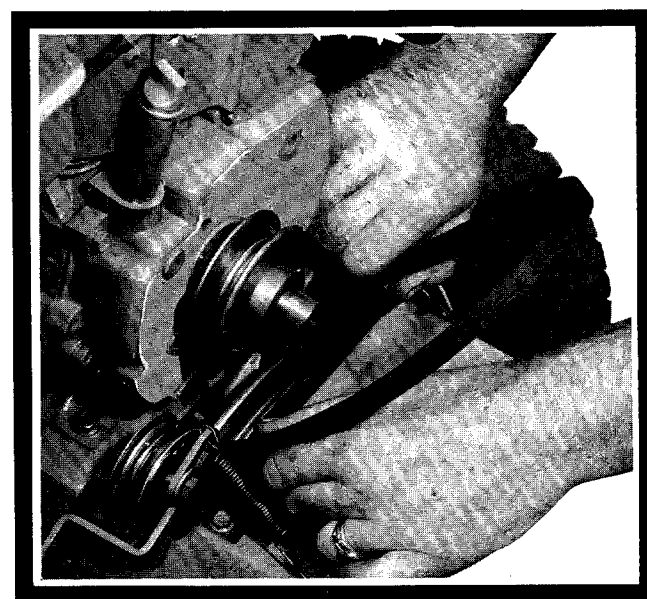
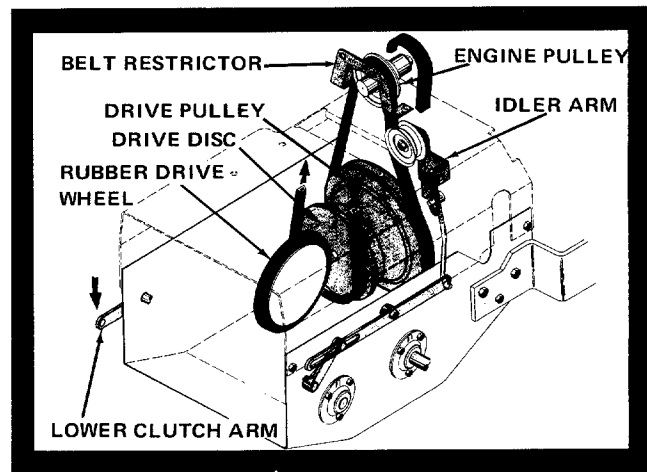
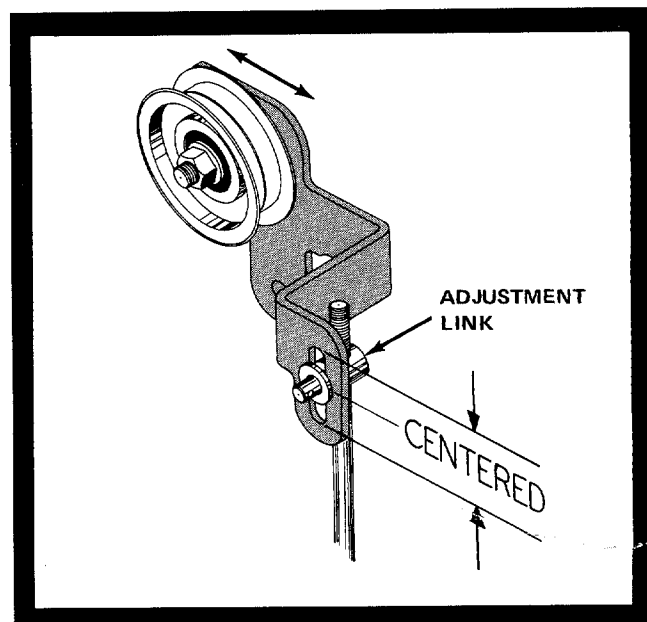

LUBRICATION

CHANGING ENGINE OIL

Drain oil when engine is warm. To drain oil, place pan under frame directly beneath oil drain access hole. Remove oil drain plug and allow oil to drain completely. Replace oil drain plug and tighten securely. Refill to "Full", approximately 1 pint. See engine manual for complete engine lubrication and service instructions.

LUBRICATION POINTS

LUBRICATE THE PARTS PERIODICALLY AS ILLUSTRATED. The following points are to be lubricated every five hours of operation with SAE 20 weight light duty oil, unless otherwise noted.

1. Spherical Bearings (Both Sides)
2. Wheels
3. Discharge Spout
4. Blower Housing
5. Reel Chain
6. Chute Adjustment Chain
7. Chain Guard Bushing
8. Universal Joint
9. Reel Bearings
10. Cable Rollers
11. Idler Arm & Linkage
12. Clutch Handle Pivot
13. Shift Yoke Slide

AFTER BREAK IN PERIOD (FIRST 3 TO 4 HOURS OF OPERATION), CHECK ALL BOLTS AND NUTS FOR TIGHTNESS.

END OF SEASON STORAGE

In the event the engine is to be stored for any length of time (30 days or more) or at the end of the snow throwing season, prepare it as outlined in the following steps:

1. Drain gas tank completely by removing fuel line at the carburetor or fuel tank, whichever is easier.
2. Drain the carburetor by pressing upward on the bowl drain.
3. To protect the engine when storing, remove the sparkplug and inject one ounce of SAE 10 weight oil through the sparkplug hole into the cylinder. Crank the engine (without starting) several times to spread the oil over the cylinder walls.
4. Lubricate all lubrication points as outlined in Lubrication Section.
5. Handles can be removed to save space by disconnecting master clutch rod, universal joint and shift lever.

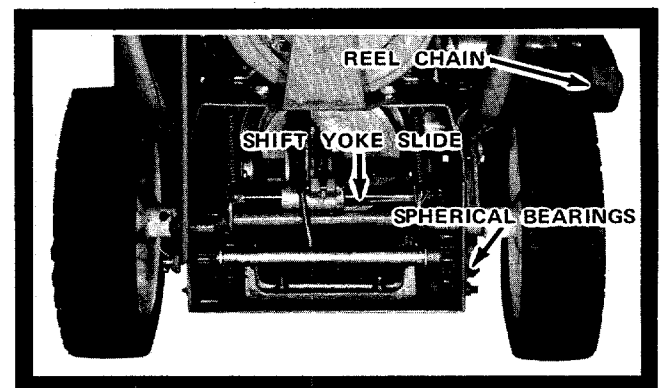
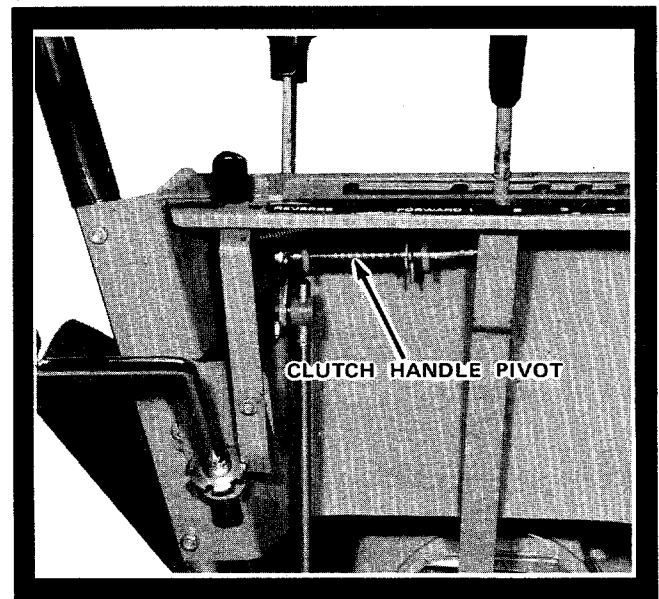
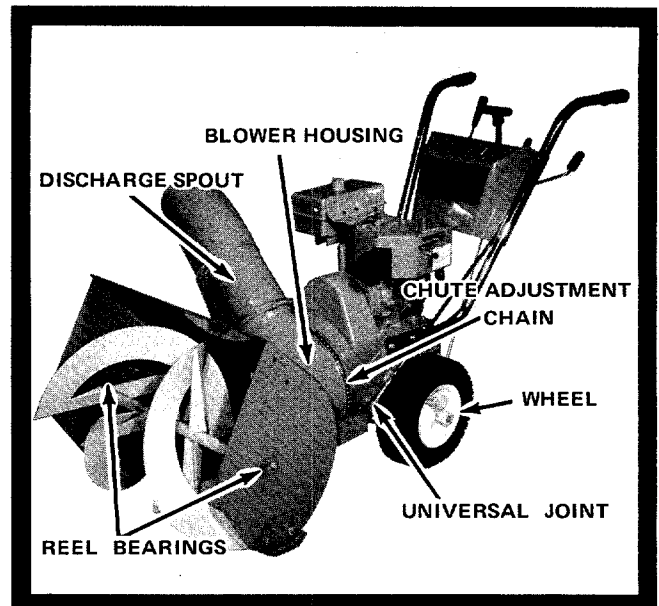

CHUTE CABLE REPLACEMENT OR REPAIR

1. REMOVE THE BLOWER HOUSING FROM THE MACHINE.

- Remove the chain guard and disconnect the reel drive chain at the chain connecting link.
- Remove the four carriage bolts, fastening the scoop to the mounting brackets. Remove the scoop and reel assembly intact. Do not remove mounting brackets from frame straps.
- Remove the spring pin and remove fan.
- Loosen chute chain to allow for removal of blower housing.
- Remove the blower housing from the unit.

2. REMOVE THE WORN CABLE.

- Place the blower housing on a bench with the cable pulley exposed.
- Remove the cable roller cover.
- Loosen the lock bolt on top of the cable roller bracket and adjust the cable adjusting bolt and cable roller in as far as possible.
- Lift the cable pulley away from the blower housing approximately 3 inches.
- Loosen the cable mounting bolt and remove the cable ends from the cable pulley.
- Loosen the nut on the cable washer which holds the cable to the upper spout assembly and remove the worn cable.

3. REPLACE NEW CABLE.

- Fasten a loop in center of the cable under the cable washer making certain that both ends of the cable are even.
- With the cable crossed, wrap each end of the cable around the upper spout.

4. PLACING THE NEW CABLE OVER THE CABLE ROLLERS.

- Rotate the upper spout assembly with the discharge side in the opposite direction from the cable pulley side of the blower housing.
- Extend the cable from the right side of the upper spout assembly over the roller on the left side of the cable roller bracket and through the left cable hole in the top of the blower housing. Extend the cable from the left side of the spout assembly across the center cable roller, back and around the cable adjustment roller and over the cable roller on the right side of the

cable roller bracket and down to the right hole in the top of the blower housing.

- Turn the cable pulley with the cable bolt toward the bottom of the blower housing.
- Put the ends of the cable up through the holes in the bottom of the cable pulley and cross the ends up and over the cable bolt and under the washer. Pull the cable tight and tighten the cable bolt and nut, making sure the cable remains in the track around the cable Pulley.
- Slide cable pulley back into place.
- Tighten cable with adjusting cable bolt.

5. REPLACE THE BLOWER HOUSING

- Reverse the steps outlined in Step 1 to replace the blower housing and parts to the Snow Thrower.

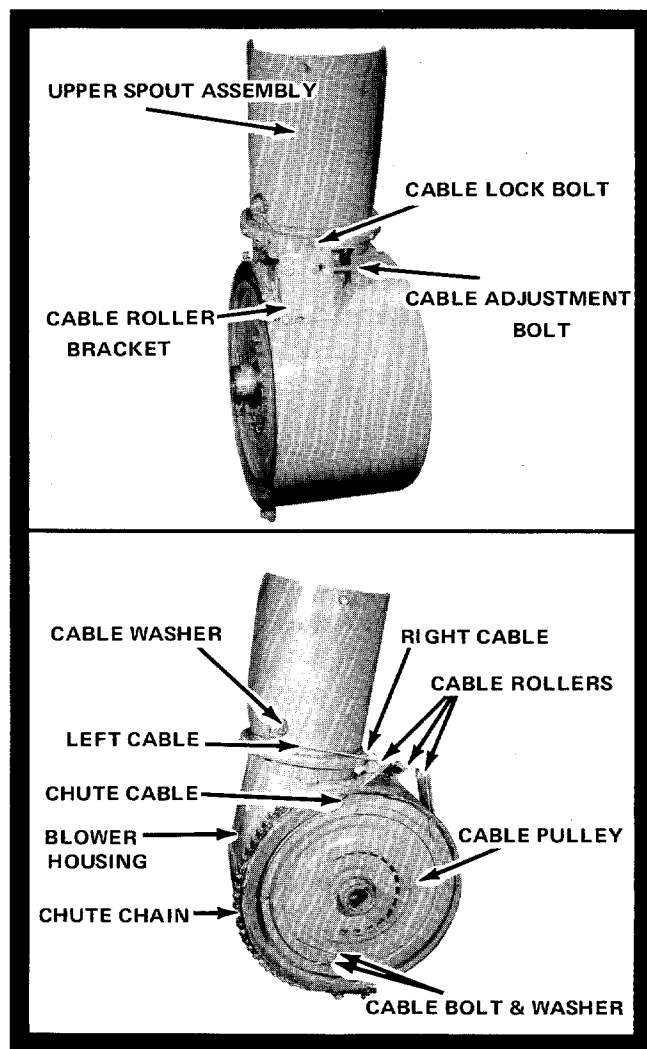

When you own this - -

YARD-MAN™

24" SNOW THROWER

you enjoy these outstanding features

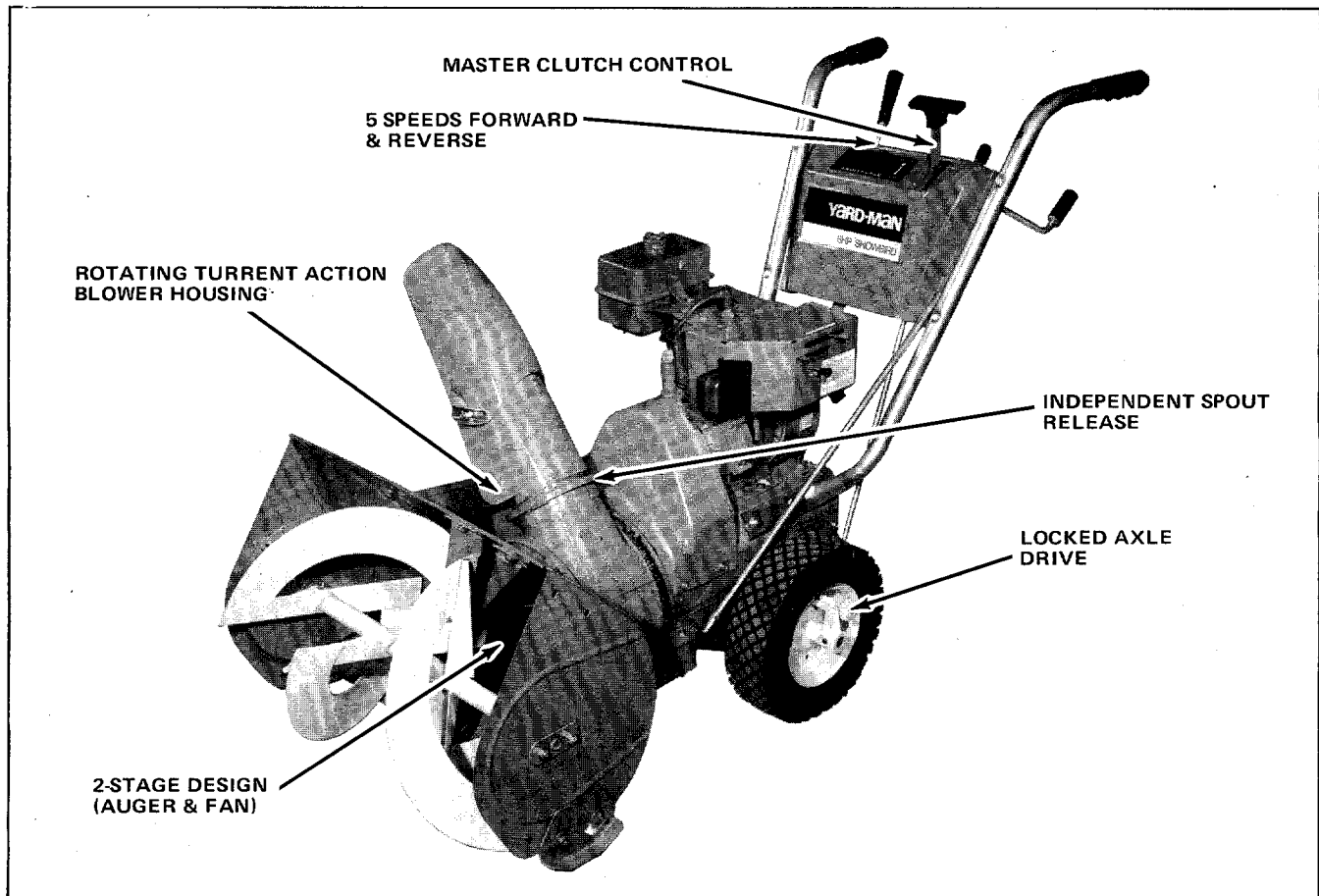

WARRANTY

We guarantee all parts against defects in material and workmanship for a period of one (1) year from the date of purchase when used for residential. 90 days for commercial.

We agree to repair or replace without charge to the original Purchaser, including labor, any part or parts upon examination by a Yard-Man Authorized Dealer to be defective within the guarantee period except the engine which is warranted separately by the manufacturer. **All transportation charges for replacement under this guarantee must be paid by the Purchaser.**

Parts for this Yard-Man unit will be available for at least ten years from the date of purchase. This guarantee will not apply to a unit which has been subjected to misuse, negligence, accident or to a unit which has been altered in any way.

YARD-MAN

a product of THE LEISURE GROUP, INC.

Yard-Man reserves the right to make engineering changes without prior notification or responsibility to the Purchaser.