

# OPERATOR'S MANUAL

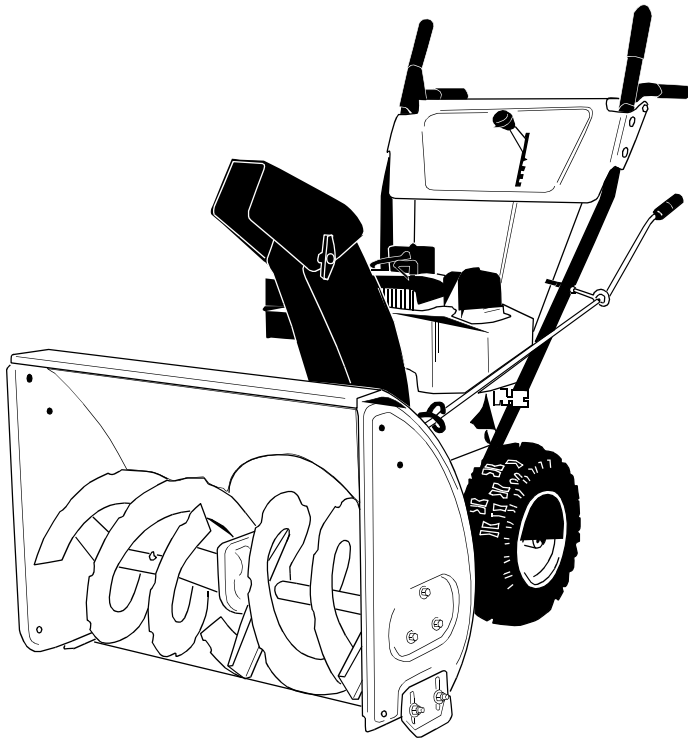

**Model Numbers**  
E662H, E642E  
614E, E644E  
E664F, E6A4E

Model Style 4 Shown

## **IMPORTANT: READ SAFETY RULES AND INSTRUCTIONS CAREFULLY**

**Warning:** This unit is equipped with an internal combustion engine and should not be used on or near any unimproved forest-covered, brush-covered or grass-covered land unless the engine's exhaust system is equipped with a spark arrester meeting applicable local or state laws (if any). If a spark arrester is used, it should be maintained in effective working order by the operator. In the State of California the above is required by law (Section 4442 of the California Public Resources Code). Other states may have similar laws. Federal laws apply on federal lands. A spark arrester for the muffler is available through your nearest engine authorized service dealer or contact the service department, P.O. Box 368022 Cleveland, Ohio 44136-9722.

**MTD PRODUCTS INC. P.O. BOX 368022 CLEVELAND, OHIO 44136-9722**

---

## SECTION 1: IMPORTANT SAFE OPERATION PRACTICES



**WARNING:** THIS SYMBOL POINTS OUT IMPORTANT SAFETY INSTRUCTIONS WHICH, IF NOT FOLLOWED, COULD ENDANGER THE PERSONAL SAFETY AND/OR PROPERTY OF YOURSELF AND OTHERS. READ AND FOLLOW ALL INSTRUCTIONS IN THIS MANUAL BEFORE ATTEMPTING TO OPERATE YOUR SNOW THROWER. FAILURE TO COMPLY WITH THESE INSTRUCTIONS MAY RESULT IN PERSONAL INJURY. WHEN YOU SEE THIS SYMBOL-HEED ITS WARNING.



**WARNING:** The Engine Exhaust from this product contains chemicals known to the State of California to cause cancer, birth defects or other reproductive harm.



**DANGER:** Your snow thrower was built to be operated according to the rules for safe operation in this manual. As with any type of power equipment, carelessness or error on the part of the operator can result in serious injury. If you violate any of these rules, you may cause serious injury to yourself or others.

### 1. TRAINING

- Read this operator's manual carefully in its entirety before attempting to assemble or operate this machine. Be completely familiar with the controls and the proper use of this machine before operating it. Keep this manual in a safe place for future and regular reference and for ordering replacement parts.
- Never allow children under 14 years old to operate a snow thrower. Children 14 years old and over should only operate snow thrower under close parental supervision. Only persons well acquainted with these rules of safe operation should be allowed to use your snow thrower.
- No one should operate this unit while intoxicated or while taking medication that impairs the senses or reactions.
- Keep the area of operation clear of all persons, especially small children and pets.
- Exercise caution to avoid slipping or falling, especially when operating in reverse.
- Before working with gasoline, extinguish all cigarettes and other sources of ignition. Check the fuel before starting the engine. Gasoline is an extremely flammable fuel. Do not fill the gasoline tank indoors, while the engine is running, or until engine has been allowed to cool at least two minutes. Replace gasoline cap securely and wipe off any spilled gasoline before starting the engine as it may cause a fire or explosion.
- Use a grounded three wire plug-in for all units with electric drive motors or electric starting motors.
- Adjust collector housing height to clear gravel or crushed rock surface.
- Never attempt to make any adjustments while engine is running (except where specifically recommended by manufacturer).
- Let engine and machine adjust to outdoor temperature before starting to clear snow.
- Always wear safety glasses or eye shields during operation or while performing an adjustment or repair, to protect eyes from foreign objects that may be thrown from the machine in any direction.

### 2. PREPARATION

- Thoroughly inspect the area where the equipment is to be used and remove all door mats, sleds, boards, wires and other foreign objects.
- Disengage all clutches and shift into neutral before starting engine.
- Do not operate equipment without wearing adequate winter outer garments. Do not wear jewelry, long scarfs or other loose clothing which could become entangled in moving parts. Wear footwear which will improve footing on slippery surfaces.

### 3. OPERATION

- Do not put hands or feet near or under rotating parts. Keep clear of discharge opening and auger at all times.
- Exercise extreme caution when operating on or crossing gravel drives, walks, or roads. Stay alert for hidden hazards or traffic. Do not carry passengers.
- After striking a foreign object, stop the engine, remove wire from spark plug, and thoroughly inspect the snow thrower for any damage. Repair the damage before restarting and operating the snow thrower.

- If the snow thrower should start to vibrate abnormally, stop the engine and check immediately for the cause. Vibration is generally a warning of trouble.
- Stop engine whenever you leave the operating position, before unclogging the collector/impeller housing or discharge guide, and making any repairs, adjustments, or inspections. Never place your hand in the discharge or collector openings. Use a stick or wooden broom handle to unclog the discharge opening.
- Take all possible precautions when leaving the unit unattended. Disengage the collector/impeller, stop the engine, and remove the key.
- When cleaning, repairing, or inspecting, make certain collector/impeller and all moving parts have stopped. Disconnect spark plug wire and keep away from plug to prevent accidental starting.
- Do not run engine indoors, except when starting engine and transporting snow thrower in or out of building. Open doors. Exhaust fumes are dangerous.
- Do not clear snow across the face of slopes. Exercise extreme caution when changing direction on slopes. Do not attempt to clear steep slopes.
- Never operate snow thrower without guards, plates, or other safety protection devices in place.
- Never operate snow thrower near glass enclosure, automobiles, window wells, drop off, etc., without proper adjustments of snow thrower discharge angle. Keep children and pets away.
- Do not overload machine capacity by attempting to clear snow at too fast a rate.

- Never operate the machine at high transport speeds on slippery surfaces. Look behind and use care when backing.
- Never direct discharge at bystanders or allow anyone in front of unit.
- Disengage power to collector/impeller when transporting or not in use.
- Use only attachments and accessories approved by the manufacturer of snow thrower (such as wheel weights, counter weights, cabs, etc.).
- Never operate the snow thrower without good visibility or light. Always be sure of your footing and keep a firm hold on the handles. Walk, never run.
- Muffler and engine become hot and can cause a burn. Do not touch.

#### 4. MAINTENANCE AND STORAGE

- Check shear bolts, engine mounting bolts, etc., at frequent intervals for proper tightness to be sure equipment is in safe working condition.
- Never store the machine with fuel in the fuel tank inside a building where ignition sources are present, such as hot water and space heaters, clothes dryers, and the like. Allow engine to cool before storing in any enclosure.
- Always refer to operator's manual instructions for important details if snow thrower is to be stored for an extended period.
- Run machine a few minutes after throwing snow to prevent freeze up of collector/impeller.
- Check clutch controls periodically to verify they engage and disengage properly and readjust if necessary. Refer to operator's manual for adjustment instructions.



**WARNING - YOUR RESPONSIBILITY:** Restrict the use of this power machine to persons who read, understand and follow the warnings and instructions in this manual and on the machine.



Figure 1

---

## SECTION 2: FINDING YOUR MODEL NUMBER

This Operator's Manual is an important part of your new snow thrower. It will help you assemble, prepare and maintain your snow thrower. Please read and understand what it says.

Before you start to prepare your snow thrower for its first use, please locate the model plate and copy the information from it in this Operator's Manual. The information on the model plate is very important if you need help from your dealer or the MTD customer support department.

- Every snow thrower has a model plate. You can locate it by standing behind the unit in the operating position and looking down at the rear frame below the engine. See Figure 2.

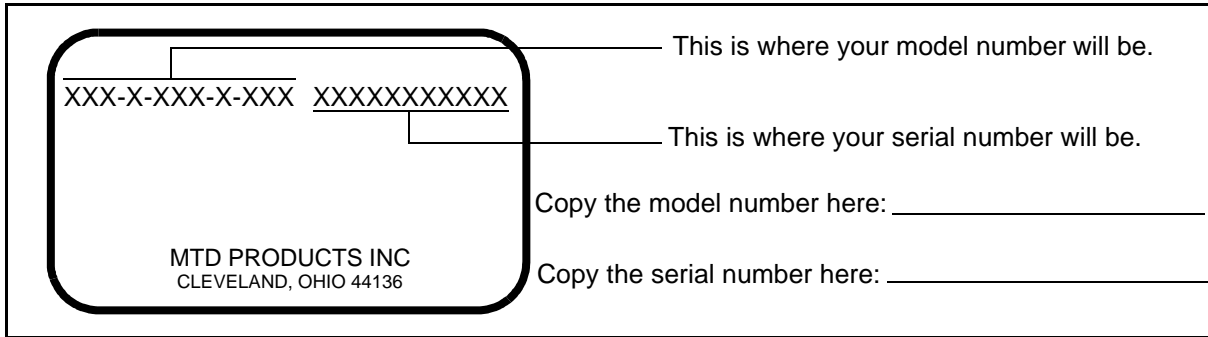

Figure 2

---

## SECTION 3: CALLING CUSTOMER SUPPORT

If you are having difficulty assembling this product or if you have any question regarding the controls, operation or maintenance of this snow thrower, please call the Customer Support Department. You can reach them by calling:

**1-800-800-7310**

Before you call, make sure that you have both your model and serial number ready. By having the model and serial number ready, you help the Customer Support Representative give you faster service. To find your units model and serial number, see SECTION 2: FINDING YOUR MODEL NUMBER.

## SECTION 4: CONTENTS OF HARDWARE PACK

Lay out the hardware according to the illustration for identification purposes. Parts are illustrated approximately one-half size. Part numbers are shown in parentheses. (Hardware pack may contain extra items which are not used on your unit.)

### A ATTACHING THE HANDLE ASSEMBLY

Hex Bolts 5/16-18 x 1-3/4" Long (710-3180)

Hex Bolts 5/16-18 x 3/4" Long (710-3008)

Lock Washers 5/16" I.D. (736-0119)

Carriage Bolts 5/16-18 x 1-1/2" Long (710-0262)

Hex Nuts 5/16-18 Thread (712-3010)

Saddle (784-5599)

### B ATTACHING THE CHUTE ASSEMBLY

Hex Bolts 1/4-20 x 3/4" Long (710-3015)

Hex Lock Nuts 1/4-20 Thread (712-3027)

Chute Flange Keepers (731-0851A)

### C ATTACHING THE CHUTE CRANK

Flat Washers 3/8" I.D. x 5/8" O.D. (736-0185)

Hex Bolt 5/16-18 x 1-1/2" Long (710-0442)

Lock Washer 5/16" I.D. (736-0119)

Hairpin Clip (714-0104)

Hex Nut 5/16-18 Thread (712-3010)

### D ATTACHING THE SHIFT ROD AND CLUTCH CABLES

Ferrule (711-0677)

Hairpin Clips (714-0104)

Flat Washers 5/16" I.D. x 5/8" O.D. (736-0264)

Jam Nuts #10-24 Thread (712-0121)

"Z"-Fitting (R) (746-0778)

### F AUGER SHEAR BOLTS

**NOTE:** The augers are secured to the spiral shaft with two shear bolts and hex lock nuts. If you hit a hard foreign object or an ice jam, the snow thrower is designed so that the bolts may shear. Two replacement shear bolts and nuts are provided for your convenience. Store in a safe place until needed.

Shear Bolts 5/16-18 x 1-1/2" Long (710-0890A)

Hex Lock Nuts 5/16-18 Thread (712-0429)

### E ATTACHING THE CLUTCH GRIPS

Hex Screw 5/16-18 x 2.0 (710-0116)

Spacer .325 I.D. x .50 O.D. x .25 (750-1032)

Hex Top L-Nut 5/16-18 (712-0429)

## SECTION 5: ASSEMBLY INSTRUCTIONS

**IMPORTANT:** After assembly, service engine with gasoline, and check oil level as instructed in the separate engine manual packed with your unit.

**NOTE:** All references to right or left side of the snow thrower are determined from behind the unit in the operating position.

### UNPACKING

1. Remove staples or break glue on the top flaps of the carton. Remove any loose parts like operator's manual or hardware pack included with unit.
2. Cut along dotted lines and lay end of carton down flat. Remove packing material.
3. Roll unit out of carton. Check carton thoroughly for loose parts.
4. Extend cables out behind unit and lay them on the floor.
5. Lay out the contents of the hardware pack according to the illustration in section 4 and identify each part.
6. Find the loose parts in the carton and lay these on the floor. See Figure 3. You should locate the following loose parts in the carton:

1. Handle Panel
2. Right Handle
3. Left Handle
4. Auger Control Grip
5. Traction Drive Control Grip
6. Right Clutch Grip Bracket
7. Left Clutch Grip Bracket
8. Shift Rod (Not Illustrated)
9. Chute Crank Assembly (Not Illustrated)
10. Chute Assembly (Not Illustrated)
11. Hardware Pack (Not Illustrated)

### TOOLS REQUIRED

The snow thrower comes partly assembled in the carton. You will have to complete the assembly. Follow assembly instructions in this operator's manual to make the job safe and easy. You will need the following tools to assemble the snow thrower.

- A. Set of Wrenches (3/8", 9/16", 1/2" or adjustable)
- B. Pair of pliers

### Attaching the Handle Assembly. (Hardware A and E)

Lay loose parts out on flat surface.

- |                       |                                |
|-----------------------|--------------------------------|
| 1. Handle Panel       | 5. Traction Drive Control Grip |
| 2. Right Handle       | 6. Right Grip Bracket          |
| 3. Left Handle        | 7. Left Grip Bracket           |
| 4. Auger Control Grip |                                |

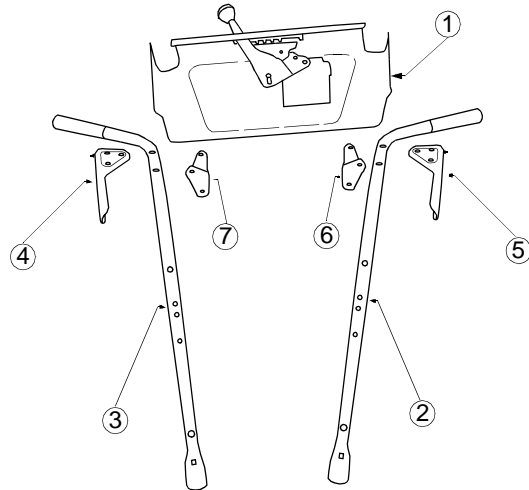

Figure 3

1. Attach left handle and grip bracket to handle panel with two carriage bolts, lock washers and hex nuts. (Be sure the bend in the grip bracket is towards the center of the handle panel. (See Figure 4.) Do not tighten at this time.

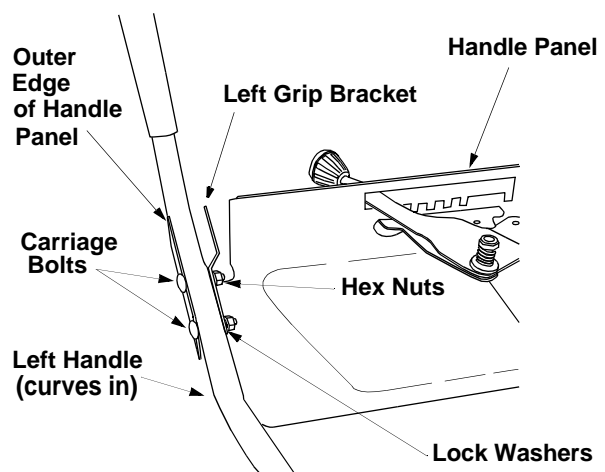

Figure 4

2. Locate auger control grip, part #4 in Figure 3. The triangular metal tab on the auger control grip must face the center of the handle panel.

3. Insert curved end of the Z fitting into the top hole in the triangular metal tab on the auger control grip. See Figure 5.

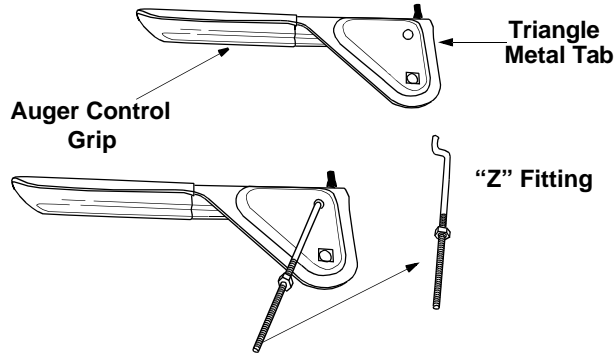

Figure 5

4. Place the auger control grip on top of the left handle. The triangular metal tab must be between the handle and the grip bracket. See Figure 6.

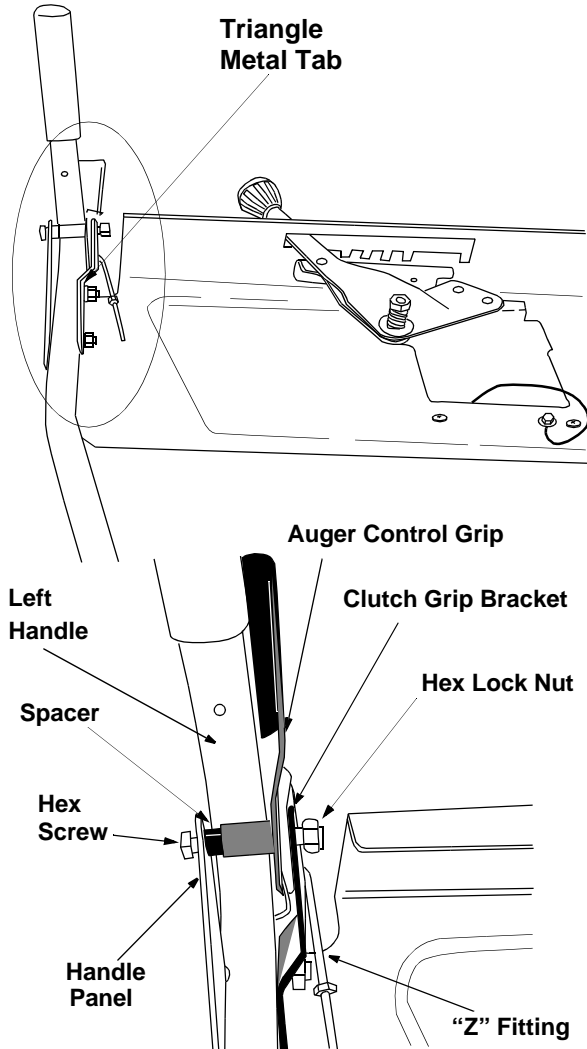

Figure 6

5. Secure with hex bolt, spacer and lock nut. See Figure 6. (Do not overtighten this bolt as it will prevent the grips from automatically returning to their upright position.)
6. Repeat process for the right side Traction Drive Control Grip.
7. Lay handle assembly behind snow thrower. See Figure 7.

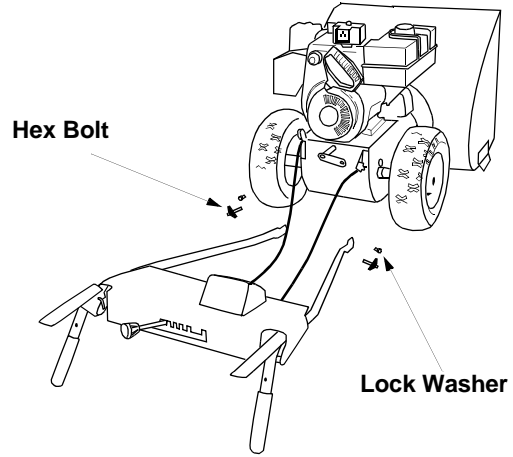

Figure 7

8. Insert a hex bolt and lock washer through the lower hole on the bottom of the handle. See Figure 7.
9. Hold the handle assembly up to the bottom of the snow thrower frame and thread the hex bolt into the lower hole in snow thrower frame. Do not tighten at this time. See Figure 8.

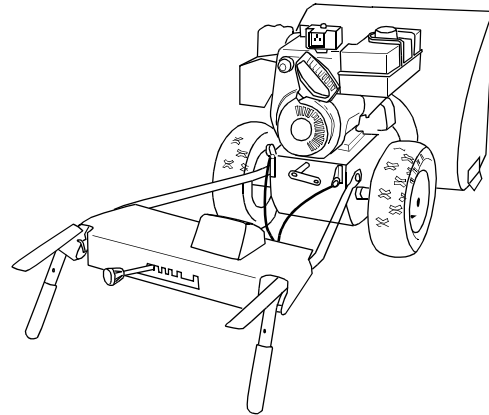

Figure 8

10. Repeat process on the other side.
11. Raise the handle assembly into the upright position and align the top holes in the handles with the top holes in the snow thrower frame. Attach using hex bolts, lock washers and saddles. (Curve in saddle must match the curve in the handle.) See Figure 9 and Figure 10.
12. Tighten four carriage bolts and nuts used to attach the handle panel to the right and left handles in step 1.
13. Tighten all hardware used to attach the handle assembly to the snow thrower frame.

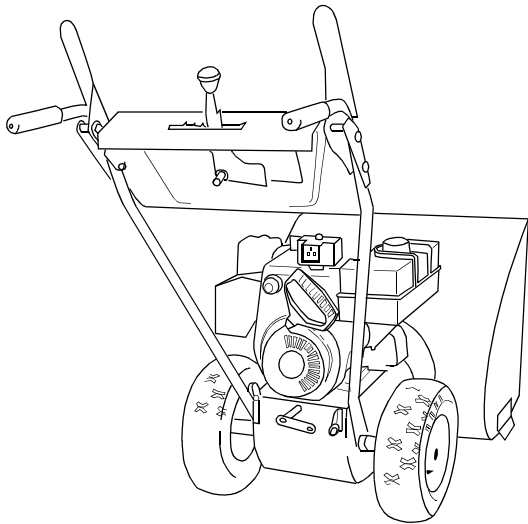

Figure 9

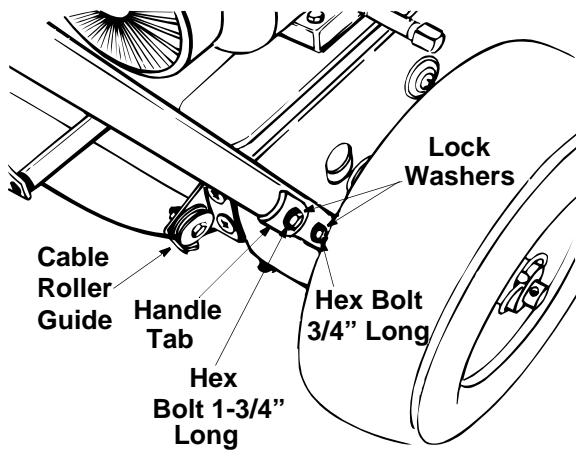

Figure 10

### ATTACHING SHIFT ROD (Hardware D)

1. Place the shift lever in the fastest forward speed position.
2. **Models 642, 662:** Rotate the shift arm assembly counter clockwise, as far as it will go. Insert the shift rod through the shift arm assembly. When installed the shift arm assembly should point to the right. Secure with flat washer and hairpin clip. See Figure 11.  
**Models 614, 644, 664 and 6A4:** Rotate the shift arm assembly counter clockwise as far as it will go. Insert the shift rod through the shift arm assembly. When installed, the shift arm assembly should point left. Secure with flat washer and hairpin clip. See Figure 12.

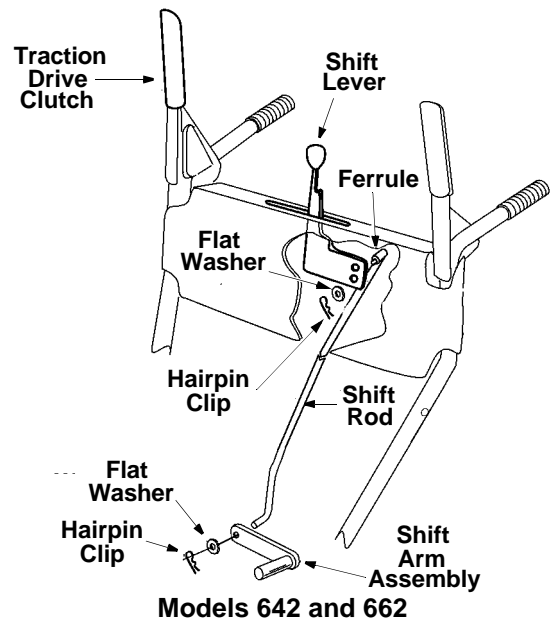

Figure 11

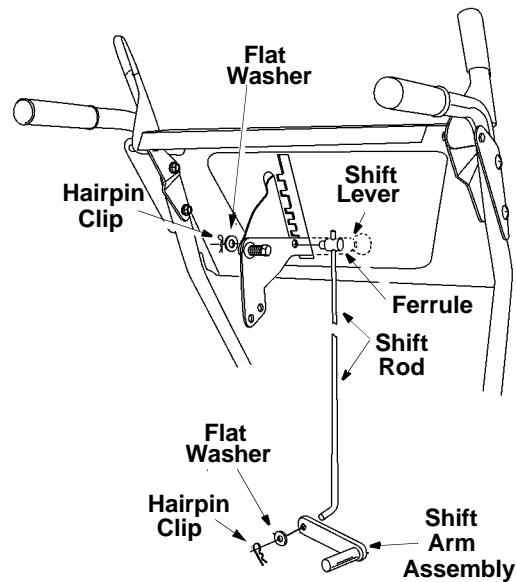

Figure 12

3. **Models 642, 662:** Thread the ferrule up or down the shift rod and align with the lower hole on the wider side of the shift lever assembly behind the handle panel. See Figure 11.  
**Models 614, 644, 664, and 6A4:** Thread the ferrule onto the shift rod, up or down the shift rod and align with the far hole on the narrow side of the shift lever assembly behind the handle panel. See Figure 12.
4. Secure the ferrule to the shift arm assembly with flat washer and hairpin clip.

**NOTE:** Make certain to check for correct adjustment of the shift rod as instructed in the FINAL ADJUSTMENTS section before operating the snow thrower.



## ATTACHING CLUTCH CABLES

### (Hardware D)

1. Thread the hex jam nuts all the way up the threaded portion of the "Z" ends.
2. Make certain all cables are in the grooves of the cable roller guides. The roller guides are located in the lower rear of the unit. Lift the clutch grip in the raised (up) position.
3. Thread the cable onto the threaded portion of the "Z" end until there is no slack in the cable, but the cable is NOT tight. Do not overtighten cable. See Figure 13.



**WARNING:** If cable is tightened so there is tension on the cable with the clutch grip released, the safety features of the snow thrower may be overridden.

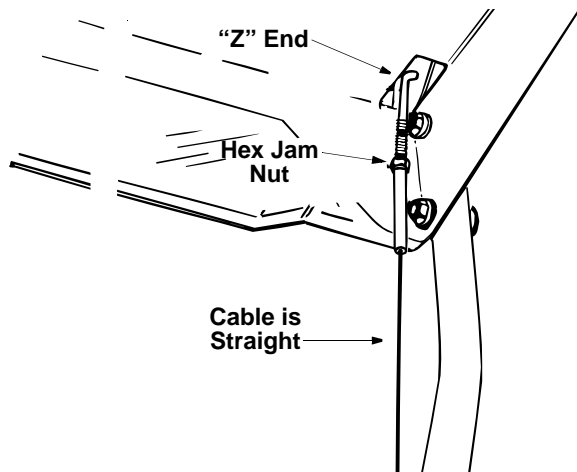

Figure 13

4. When correct adjustment is reached, tighten the hex nut against the cable to lock it in position.

## ATTACHING THE CHUTE ASSEMBLY

### (Hardware B)

1. Place chute assembly over chute opening, with the opening in the chute assembly facing the front of the unit.
2. Place chute flange keepers beneath lip of chute assembly, flat side down.
3. Insert hex bolt up through chute flange keeper and chute assembly as shown in Figure 14. Secure with hex lock nut.
4. After assembling all three chute flange keepers, tighten all nuts and bolts securely, then back off 1/4 turn to allow easier movement.

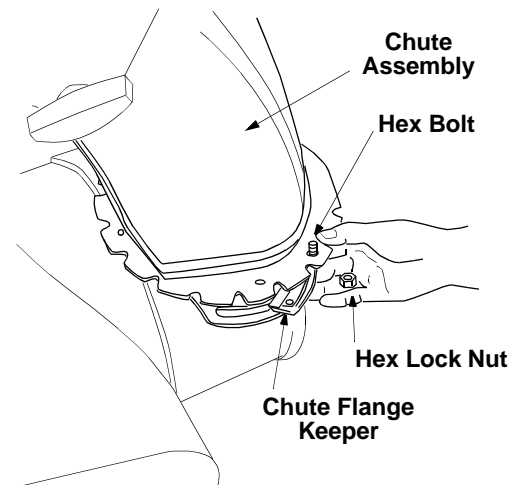

Figure 14

## ATTACHING THE CHUTE CRANK

### (Hardware C)

1. Insert hex bolt through the upper chute crank bracket (located on the chute crank). See Figure 15.

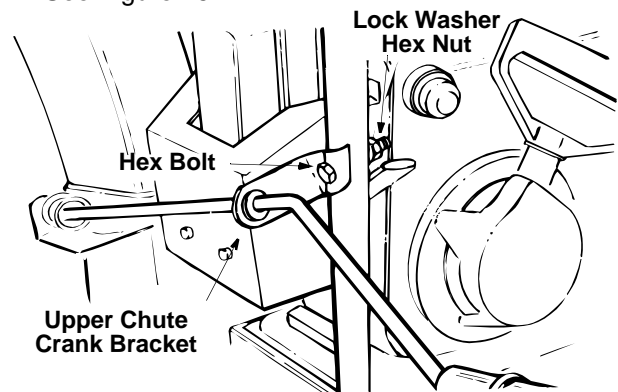

Figure 15

2. Place the hex bolt into the hole provided in the left handle. Secure with lock washer and hex nut. Do not tighten at this point.
3. Loosen the carriage bolts and hex lock nuts which secure the lower chute crank bracket to the extension on the left side of the chute assembly. See Figure 16.

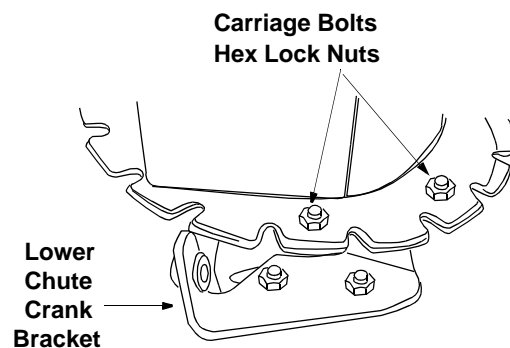

Figure 16

- Place one flat washer on the end of the chute crank, then insert the end of the crank into the hole in the plastic bushing in the chute crank bracket. See Figure 17.

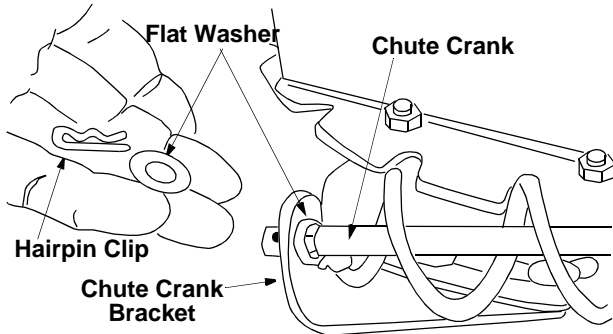

Figure 17

- Place the other flat washer on the end of the chute crank, and insert hairpin clip into hole in the end of crank. See Figure 17.
- Adjust the chute bracket so that the spiral on the chute crank fully engages the teeth on the chute assembly.
- Tighten the nuts on the lower chute crank bracket securely. Tighten the hex bolt and nut on the upper chute crank bracket on the handle.

### LAMP WIRING (If Equipped)

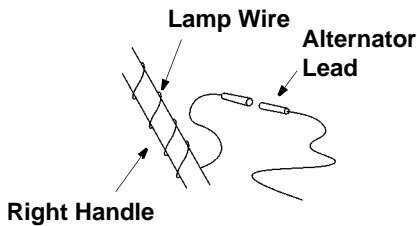

Figure 18

- Wrap the wire from the lamp down the right handle until the wire can be plugged into the alternator lead wire under the fuel tank. See Figure 18. Be sure lamp wire does not interfere with the movement of any controls or cables.

**IMPORTANT:** After attaching the shift rod and clutch cables, check the adjustments as instructed, and make any final adjustments necessary before operating your snow thrower. Failure to follow the instructions may cause damage to the snow thrower.

## FINAL ADJUSTMENTS

### Auger Drive Clutch

- To check the adjustment of the auger drive clutch, push forward on the left hand clutch grip depressing the rubber bumper under the clutch grip. There should be slack in the cable.
- Release the clutch grip. The cable should be straight. Make certain you can depress the auger drive clutch grip against the left handle completely.
- If necessary, loosen the hex jam nut and thread the cable in (for less slack) or out (for more slack) as necessary. Refer to Figure 13. Recheck the adjustment. Tighten the jam nut against the cable when correct adjustment is reached.

### Traction Drive Clutch and Shift Lever Adjustment

To check the adjustment of the traction drive clutch and shift lever:

- Move the shift lever all the way to the highest speed. With the traction drive lever released, push the snow thrower forward. The unit should roll forward.
- Then engage the traction drive clutch grip. The wheels should stop turning.
- Now release the traction drive clutch grip, and push the unit again. Move the shift lever back to the fast reverse position, then all the way forward again. There should be no resistance in the shift lever, and the wheels should keep turning.
- If you have resistance when moving the shift lever or the wheels stop when they should not, loosen the jam nut on the traction drive cable and unthread the cable one turn. If the wheels do not stop when you engage the traction drive clutch grip, loosen the jam nut on the traction drive cable and thread the cable in one turn. Recheck the adjustment and repeat as necessary.
- Tighten the jam nut to secure the cable when correct adjustment is reached.

**NOTE:** If you are uncertain that you have reached the correct adjustment, refer to SECTION 8: ADJUSTMENTS.

## Adjusting The Skid Shoes

The space between the shave plate and the ground can be adjusted by adjusting the skid shoes.

1. Place skid shoes in the low position to remove snow close to the ground. Place skid shoes in a higher position to remove snow from uneven ground. See Figure 19.
2. Adjust skid shoes by loosening the four hex nuts and carriage bolts and moving skid shoes to desired position. Make certain the entire bottom surface of skid shoe is against the ground to avoid uneven wear on the skid shoes. Retighten nuts and bolts securely.

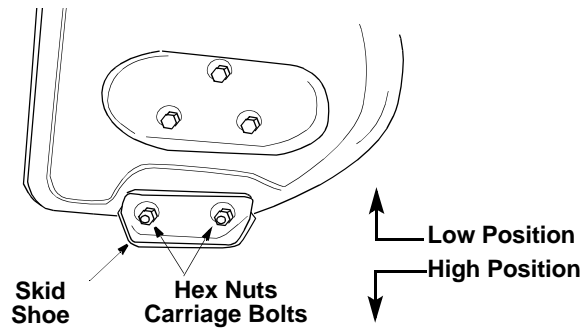

Figure 19



**WARNING:** It is not recommended that you operate this snow thrower on gravel as loose gravel can be easily picked up and thrown by the auger causing an injury and/or damage to the snow thrower.

## SECTION 6: CONTROLS

### THROTTLE CONTROL

The throttle control is located on the engine. It regulates the speed of the engine. See Figure 21

### SAFETY IGNITION SWITCH

The ignition key must be inserted in the switch before the unit will start. Remove the ignition key when snow thrower is not in use

### FUEL SHUT-OFF VALVE

The fuel shut-off valve, located under fuel tank, controls fuel flow from tank. (If equipped)  
See Figure 20.

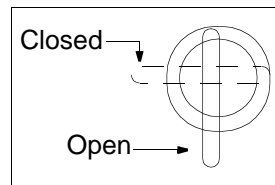

Figure 20

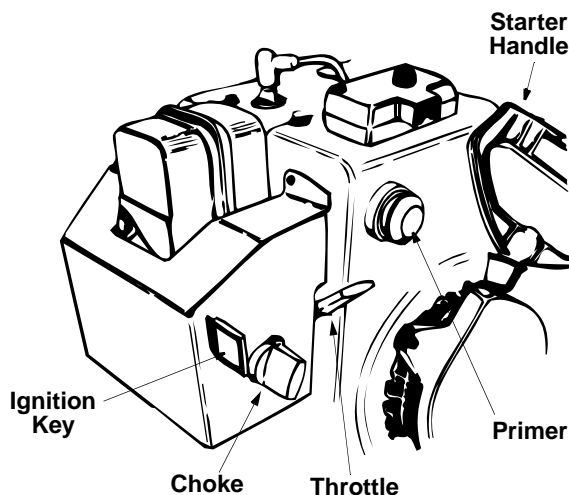

Figure 21

### SHIFT LEVER

(See Figure 22 for Model 642 and 662. See Figure 23 for Models 614, 644, 664, and 6A4)

The shift lever is located in the center of the handle panel. The shift lever may be moved into one of six positions. Run engine with throttle in the fast position. Use the shift lever to determine ground speed.

**Forward**—Five forward speeds: position one (1) is the slowest; position five (5) is the fastest.

**Reverse**—One reverse (R) speed.

**NOTE:** Model 614, 644, 664, and 6A4 has seven positions.

### AUGER DRIVE CLUTCH

(See Figure 22 for Model 642 and 662. See Figure 23 for Models 614, 644, 664, and 6A4)

The auger drive clutch is located on the left handle. Squeeze the auger drive clutch against the handle to engage the augers. Release to stop the snow throwing action.

### TRACTION DRIVE CLUTCH

(See Figure 22 for Model 642 and 662. See Figure 23 for Models 614, 644, 664, and 6A4)

The traction drive clutch is located on the right handle. Squeeze the traction drive clutch to engage the wheel drive. Release to stop.

### CHUTE CRANK

(See Figure 22 for Model 642 and 662. See Figure 23 for Models 614, 644, 664, and 6A4)

The chute crank is located on left hand side of the snow thrower.

To change the direction in which snow is thrown, turn chute crank as follows:

Crank clockwise to discharge to the left.

Crank counterclockwise to discharge to the right.

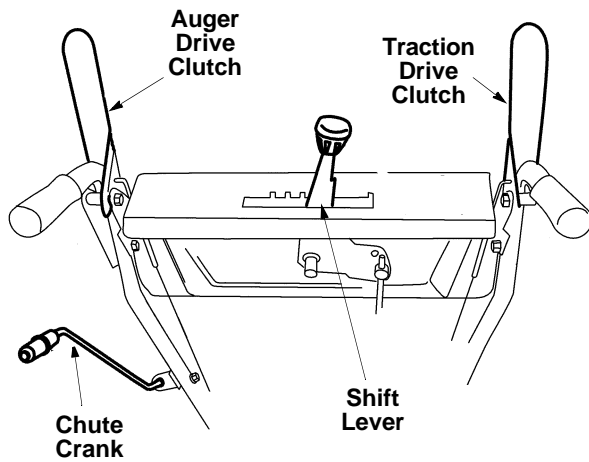

Models 642 and 662

Figure 22

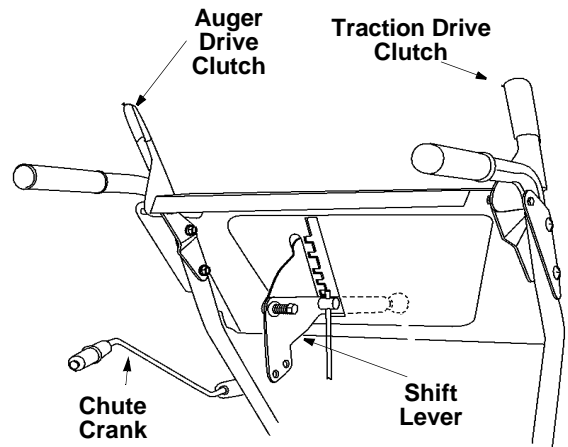

Models 614, 644, 664, and 6A4

Figure 23

## SECTION 7: OPERATION

### BEFORE STARTING

**WARNING:** Observe all Warning Labels on the snow thrower prior to use. See Figure 1.

Your snow thrower is shipped with oil; however, you must check the oil level before operating. Be careful not to overfill.

The spark plug wire was disconnected for safety. Attach spark plug wire to spark plug before starting

### GAS AND OIL FILL-UP

Check oil level and add oil if necessary. Service the engine with gasoline as instructed in the separate engine manual packed with your snow thrower. Read instructions carefully.

**WARNING:** Never fill fuel tank indoors, with engine running or while engine is hot. Do not smoke when filling fuel tank.

### TO START ENGINE

**NOTE:** If unit shows any sign of motion (drive or augers) with the clutch grips disengaged, shut engine off immediately. Readjust as instructed in the Final Adjustments section of SECTION 5: ASSEMBLY INSTRUCTIONS.

1. Attach spark plug wire to spark plug. Make certain the metal loop on end of the spark plug wire (inside the boot) is fastened securely over the metal tip on the spark plug. See Figure 24.
2. Make certain the fuel cutoff valve is in the OPEN (vertical) position. See Figure 20.

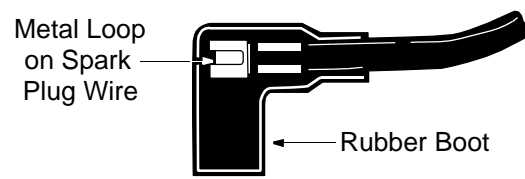
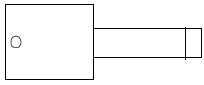

Figure 24

3. Make certain the auger and drive clutch levers are in the disengaged (released) position.
4. Move throttle control up to FAST position. Insert ignition key into slot. See Figure 21. Be certain it snaps into place. Do not turn key.

ENGINE WILL NOT START UNLESS IGNITION KEY IS INSERTED INTO IGNITION SLOT IN CARBURETOR COVER. DO NOT TURN IGNITION KEY.



### Electric Starter: (If Equipped)

**WARNING:** The electric starter is equipped with a three-wire power cord and plug, and is designed to operate on 120 volt AC household current. It must be properly grounded at all times to avoid the possibility of electric shock which may be injurious to the operator. Follow all instructions carefully. If the house wiring system is not a three-wire grounded system, do not use this electric starter under any conditions.

Follow all instructions carefully. Determine that your house wiring is a three wire grounded system. Ask a licensed electrician if you are not certain. If your house wiring system is not a three-wire grounded system, do not use this electric starter under any conditions. If your system is grounded and a three-hole receptacle is not available at the point your starter will normally be used, one should be installed by a licensed electrician.

When connecting the power cord, always connect cord to starter on engine first, then plug the other end into a three-hole grounded receptacle.

When disconnecting the power cord, always unplug the end from the three-hole grounded receptacle first.

1. Make certain the auger drive and traction drive clutch grips are in the disengaged (released) position.
2. Move throttle control up to FAST position. Insert ignition key into slot. Refer to Figure 21. Be certain it snaps into place. **Do not** turn key.
3. Rotate choke knob to OFF position.
4. Connect power cord to switch box on engine. Plug the other end of power cord into a three-hole, grounded 120 volt AC receptacle.
5. Push starter button on top of the engine to crank engine. As you crank the engine, move choke knob to FULL choke position.
6. When engine starts, release starter button, and move choke gradually to OFF. If engine falters, move choke immediately to FULL and then gradually to OFF.
7. Repeat steps 6 and 7 until engine starts. If engine fails to start, repeat steps 5, 6, and 7 until engine starts.
8. As engine warms up and begins to operate evenly, rotate choke knob slowly to OFF position. If engine falters, return to FULL choke, then slowly move to OFF position.

### Recoil Starter.

1. Make certain the auger drive and traction drive clutch grips are in the disengaged (released) position.
2. Move throttle control up to FAST position. Insert ignition key into slot. Refer to Figure 21. Be certain it snaps into place. **Do not** turn key.
3. Rotate choke knob to FULL choke position (cold engine start).  
If engine is warm, place choke in OFF position instead of FULL.

4. Push primer button two or three times. Refer to Figure 21. If engine is warm, push primer button once only.

**NOTE:** Always cover vent hole in primer button when pushing. Additional priming may be necessary for first start if temperature is below 15°F.

5. Grasp starter handle (refer to Figure 21) and pull rope out slowly, until it pulls slightly harder. Let rope rewind slowly.
6. Pull starter handle rapidly. Do not allow handle to snap back. Allow it to rewind slowly while keeping a firm hold on the starter handle.
7. Repeat steps 6 and 7 until engine starts. If engine fails to start, repeat steps 5, 6 and 7 until engine starts.

### TO STOP ENGINE

1. Run engine for a few minutes before stopping to help dry off any moisture on the engine.
2. To help prevent possible freeze-up of starter, proceed as follows.

### Electric Starter:

Connect power cord to switch box on engine, then to 120 volt AC receptacle. With the engine running, push starter button and spin the starter for several seconds. The unusual sound made by spinning the starter will not harm engine or starter. Disconnect the power cord from receptacle first, and then from switch box.

### Recoil Starter:

With engine running, pull starter rope with a rapid, continuous full arm stroke three or four times. Pulling the starter rope will produce a loud clattering sound, which is not harmful to the engine or starter.

3. To stop engine, remove the ignition key. **Do not** turn key. Disconnect the spark plug wire from the spark plug to prevent accidental starting while equipment is unattended.

**NOTE:** Do not lose ignition key. Keep it in a safe place. Engine will not start without the ignition key.

4. Wipe all snow and moisture from the carburetor cover in the area of the control levers. Also, move control levers back and forth several times. Leave throttle control lever in the STOP or OFF position. Leave choke control in the FULL choke position.

## TO ENGAGE DRIVE/AUGER

1. With the engine running near top speed, move shift lever into one of the FORWARD or REVERSE positions. Select a speed appropriate for the snow conditions that exist. Use the slower speeds until you are familiar with the operation of the snow thrower.
2. Squeeze the left hand auger drive clutch to engage auger.
3. While the left hand auger drive clutch is engaged, engage the right hand traction drive clutch.

**NOTE:** NEVER move shift lever without first releasing the drive clutch.

## TIRE CHAINS (OPTIONAL):

Use tire chains when extra traction is necessary.

## OPERATING TIPS

**NOTE:** Allow the engine to warm up for a few minutes as the engine will not develop full power until it reaches operating temperature.



**WARNING:** Temperature of muffler and surrounding areas may exceed 150°F. Avoid these areas.

- For most efficient snow removal, remove snow immediately after it falls.
- Discharge snow downwind whenever possible. Slightly overlap each previous swath.
- Set the skid shoes 1/4" below the scraper bar for normal usage. The skid shoes may be adjusted upward for hard-packed snow. Adjust downward when using on gravel or crushed rock.
- Be certain to follow the precautions listed under "To Stop Engine" in previous column to prevent possible freeze-up.
- Clean the snow thrower thoroughly after each use.

---

## SECTION 8: ADJUSTMENTS



**WARNING:** Never attempt to clean chute or make any adjustments while engine is running.

### ADJUSTING CHUTE

You can control the distance that snow is thrown by adjusting the angle of the chute assembly. The sharper the angle, the shorter the distance snow is thrown.

1. To adjust the chute, loosen the hand knob. See Figure 25.
2. Pivot the top of the chute assembly to the position desired.

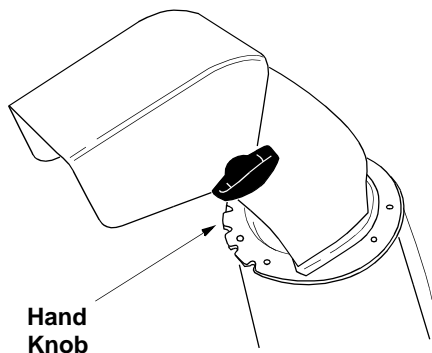

Figure 25

### ADJUSTING SKID SHOE

The space between the shave plate and the ground can be adjusted by adjusting the skid shoe. Slide the skid shoe upwards and lower the housing to remove snow close to the ground. Slide skid shoe downwards and raise the housing to remove snow from uneven ground like gravel. For more details, refer to Adjusting the Skid Shoes in section 5.

### ADJUSTING TRACTION DRIVE CLUTCH

Refer to the Final Adjustments section on page 10 for instructions to adjust the traction drive clutch. If you are not sure whether you have been able to adjust the traction drive clutch properly, check as follows.

1. Drain the gasoline from the snow thrower or put a plastic film under the gas cap if the snow thrower has already been operated. Tip the snow thrower forward onto the auger housing.
2. Remove the frame cover underneath the snow thrower by removing the six self-tapping screws.
3. With the traction drive clutch released, check if there is clearance between the friction wheel and the drive plate in all positions of the shift lever. For correct adjustment there has to be enough clearance.
4. With the traction drive clutch engaged, check if the friction wheel is contacting the drive plate. See Figure 26.

- If adjustment is necessary, loosen the jam nut on the traction drive cable, and thread cable in or out as necessary.
- Tighten the jam nut to secure the cable when correct adjustment is reached. Reassemble the frame cover with six self-tapping screws.

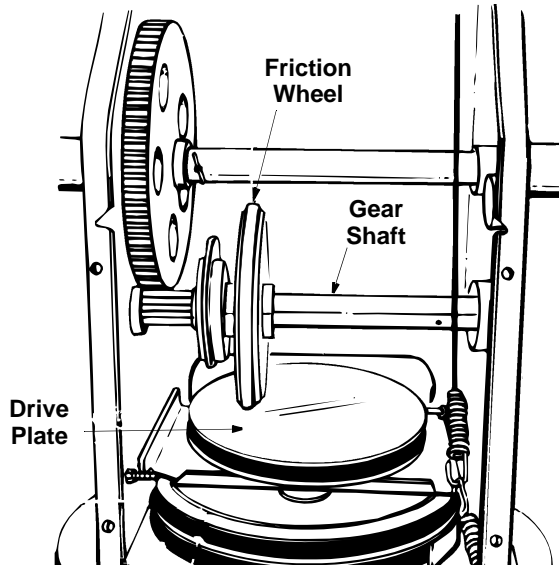

Figure 26

**Note:** If you had earlier placed plastic film under the gas cap, be sure to remove it once the adjustment to the traction drive clutch is done and the snow thrower frame is re-installed.

### ADJUSTING AUGER CLUTCH

To adjust the auger clutch, refer to the Final Adjustments in section 5.

### ADJUSTING SHIFT ROD

- Remove the hairpin clip and flat washer from the ferrule and remove the ferrule from the shift lever. Place the shift lever in the fastest forward speed position.

#### Models 642, 662:

- Push up on the shift arm assembly as far as it will go. Thread the ferrule up or down the shift rod and align with the lower hole on the wider side of the shift lever assembly behind the handle panel. Secure the ferrule to the shift arm assembly again with the hardware earlier removed.

#### Models 614, 644, 664, and 6A4:

- Push down on the shift arm assembly as far as it will go. Thread the ferrule up or down the shift rod and align it with the hole closest to the shift knob on the narrow side of the shift lever assembly behind the handle panel.

**NOTE:** Make certain to check for correct adjustment of the shift rod as instructed in the Final Adjustments section before operating the snow thrower.

### CARBURETOR ADJUSTMENT



**WARNING:** If any adjustments are made to the engine while the engine is running (e.g. carburetor), keep clear of all moving parts. Be careful of heated surfaces and muffler.

Minor carburetor adjustment may be required to compensate for differences in fuel, temperature, altitude and load.

Refer to the separate engine manual packed with your unit for carburetor adjustment information.

### DRIVE WHEELS

The wheels may be adjusted for two different methods of operation. The adjustment is made by placing the click pins in one of two different holes on the right side of the unit. See Figure 27.

- One Wheel Driving**—Place click pin in the outside axle hole on the right side. This position gives power drive to the left wheel only, making the unit easier to maneuver.
- Both Wheels Driving**—Place click pin in the hole in the hub next to the rim on the right side. This position is good for heavy snow as there is power drive in both wheels.

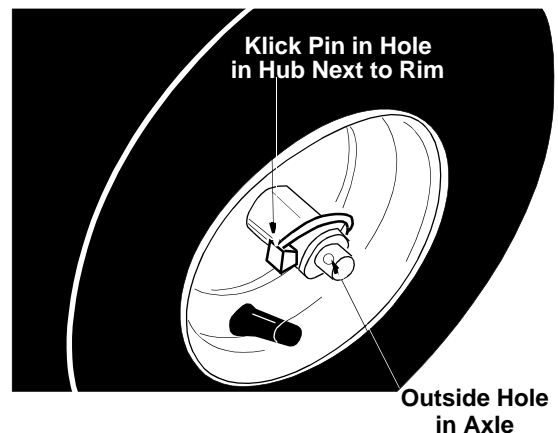

Figure 27

---

## SECTION 9: LUBRICATION



**WARNING:** Disconnect the spark plug wire and ground against the engine before performing any lubrication or maintenance.

### ENGINE

Refer to engine manual for all engine lubrication instructions.



**WARNING:** When following instructions in separate engine manual for draining oil, be sure to protect frame to avoid oil dripping onto transmission parts.

### CHUTE CRANK

The gear on the end of the chute crank should be greased with multi-purpose automotive grease once a season.

### AUGER SHAFT

At least once a season, remove shear bolts on auger shaft. Oil or spray lubricant inside shaft. See Figure 28. Also lubricate the auger bearings at least once a season.

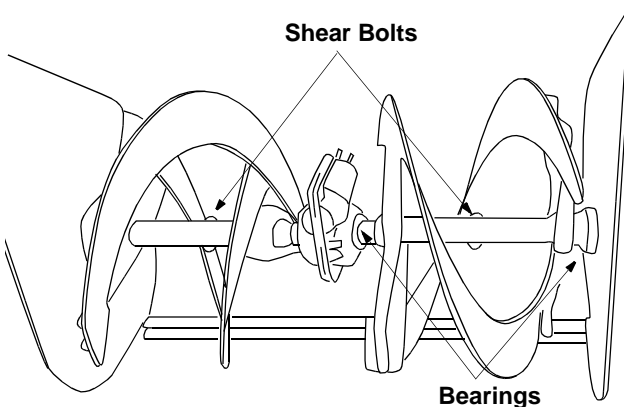

Figure 28

### SPROCKET SHAFT

Lubricate the sprocket shaft with a light oil at least once a season or after every 25 hours of operation.

**IMPORTANT:** Keep all grease and oil off of the rubber friction wheel and aluminum drive plate.

### DRIVE AND SHIFTING MECHANISM

At least once a season or after every 25 hours of operation, remove the bottom frame cover. Lubricate any chains, sprockets, gears, bearings, shafts, and shifting mechanism at least once a season. Use engine oil or a spray lubricant. **Avoid getting oil on rubber friction wheel and aluminum drive plate.**

### GEAR CASE

The gear case is lubricated with grease at the factory and does not require checking. If disassembled for any reason, lubricate with 2 ounces of shell grease, part number 737-0168.

**IMPORTANT:** Do not overfill the gear case. Damage to the seals could result. Be sure the vent plug is free of grease in order to relieve pressure.

---

## SECTION 10: MAINTENANCE

### AUGERS

The augers are secured to the spiral shaft with two shear bolts and hex lock nuts. Refer to Figure 28. If you hit a hard foreign object or ice jam, the snow thrower is designed so that the hex bolts will shear. If the augers will not turn, check to see if the bolts have sheared. Two replacement shear bolts and hex lock nuts have been provided with the snow thrower. For future use, order part number 710-0890 (shear bolt 5/16-18 x 1.5" long) and 712-0429 (hex insert lock nut 5/16-18 thread).

### SHAVE PLATE AND SKID SHOES

The shave plate and skid shoes on the bottom of the snow thrower are subject to wear. They should be checked periodically and replaced when necessary. To remove skid shoes, remove the four carriage bolts, belleville washers and hex nuts which attach them to the snow thrower. Reassemble new skid shoes with the four carriage bolts, belleville washers (cupped side goes against skid shoes) and hex nuts. Make certain the skid shoes are adjusted to the same level on both sides.

To remove shave plate, remove the carriage bolts, belleville washers and hex nuts which attach it to the snow thrower housing. Reassemble new shave plate, **making sure heads of the carriage bolts are to the inside of the housing.** Tighten securely.

### ENGINE

Refer to separate engine manual for all engine maintenance procedures.

### BELT REMOVAL AND REPLACEMENT



**WARNING:** Disconnect the spark plug wire from the spark plug and ground.



## AUGER BELTS

**NOTE:** It is necessary to remove both belts in order to change either one. If changing just one belt, be certain to check the condition of the other belt.

1. Remove the plastic belt cover on the front of the engine by removing the two self-tapping screws. See Figure 29.
2. Drain the gasoline from the snow thrower, or place a piece of plastic under the gas cap.
3. Tip the snow thrower up and forward so that it rests on the auger housing.

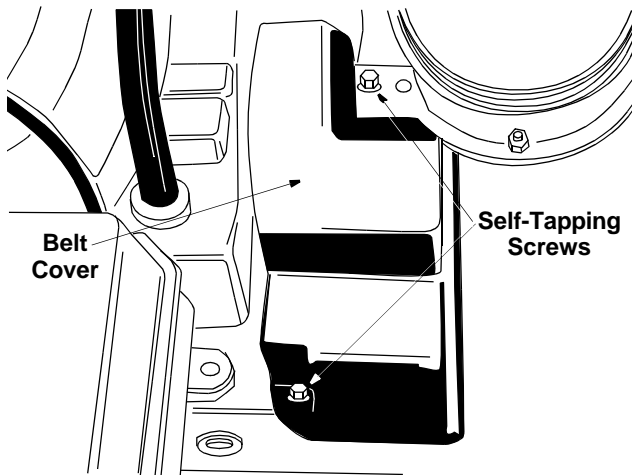

Figure 29

4. Remove six self-tapping screws from the frame cover underneath the snow thrower.

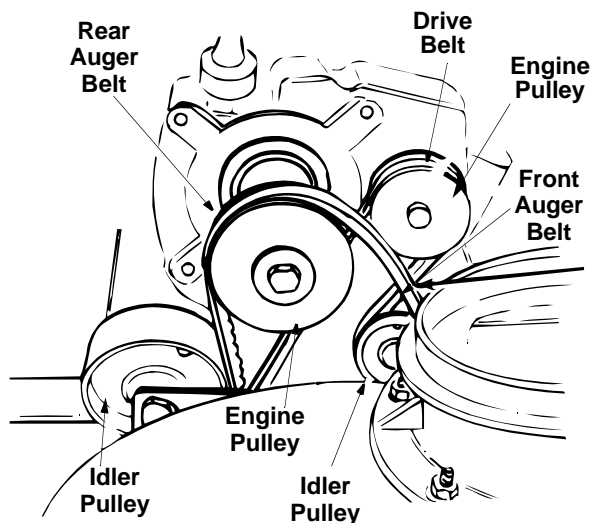

Figure 30

**NOTE:** It may be necessary to loosen the six hex nuts that fasten the frame to the auger housing to aid in belt removal.

5. Roll the front and rear auger belts off the engine pulley. See Figure 30.
6. Unhook the idler spring from the hex bolt on the auger housing. See Figure 31.
7. Back out the stop bolt to allow the belts to slip between the bolt and auger pulley. See Figure 32.
8. Lift the rear auger belt from the auger pulley, and slip belt between the support bracket and the auger pulley. See Figure 31. Repeat this step for front auger belt.
9. Replace both auger drive belts by following instructions in reverse order.

## DRIVE BELT

1. Follow steps 1 through 4 of previous instructions.
2. Pull idler pulley up, and lift belt off engine pulley, idler pulley, and friction wheel disc. See Figure 30.
3. Back out the stop bolt until the support bracket rests on the auger pulley. See Figure 32.
4. Slip belt between friction wheel and friction wheel disc. See Figure 31. Remove and replace belt. Reassemble following the instructions in reverse order.

**NOTE:** The support bracket must rest on the stop bolt after the new belt has been assembled. See Figure 32.

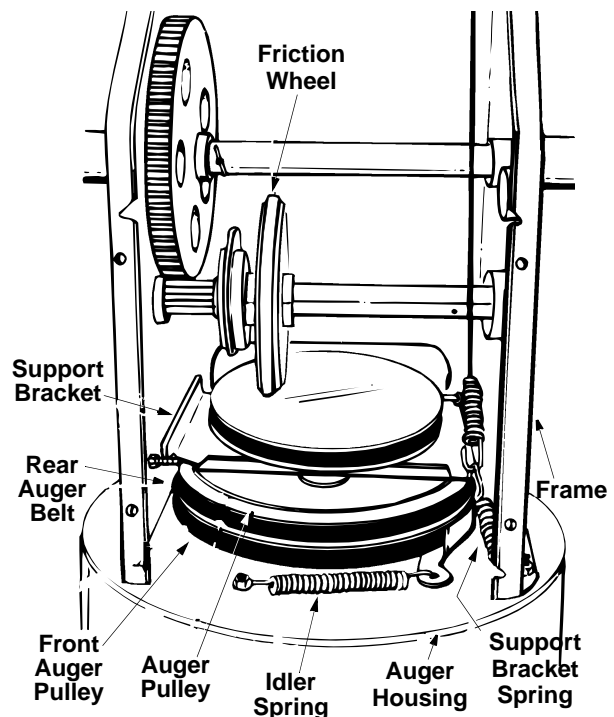

Figure 31

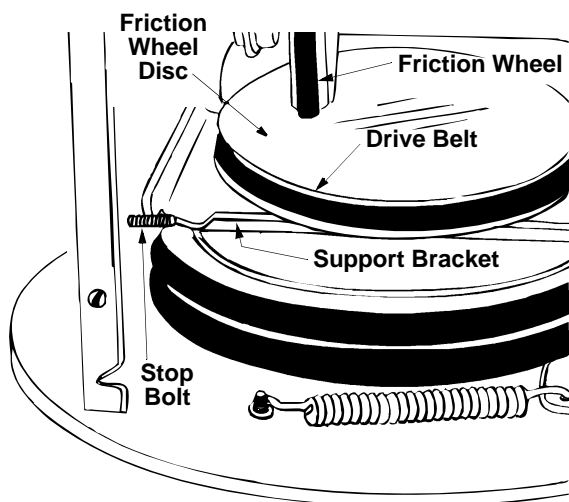

Figure 32

## CHANGING THE FRICTION WHEEL RUBBER

The rubber on the friction wheel is subject to wear and should be checked after 25 hours of operation, and periodically thereafter. Replace the friction wheel rubber if any signs of wear or cracking are found.

1. Drain the gasoline from the snow thrower, or place a piece of plastic under the gas cap.
2. Tip the snow thrower up and forward, so that it rests on the auger housing.
3. Remove six self-tapping screws from the frame cover underneath the snow thrower.
4. Remove the click pins which secure the wheels, and remove the wheels from the axle.
5. Using a 7/8" wrench to hold the shaft, loosen, but do not completely remove, the hex nut and bell washer on the left end of gear shaft. See Figure 33.

6. Lightly tap the hex nut to dislodge the ball bearing from the right side of frame. Remove the hex nut and bell washer from left end of shaft.
7. Slide the gear shaft to the right and slide the friction wheel assembly from the shaft.
8. Remove the six screws from the friction wheel assembly (three from each side). Remove the friction wheel rubber from between the friction wheel plates.
9. Reassemble new friction wheel rubber to the friction wheel assembly, tightening the six screws in rotation and with equal force.

Position the friction wheel assembly up onto the pin of the shift rod assembly, and slide the shaft through the assembly. Reassemble in reverse order.

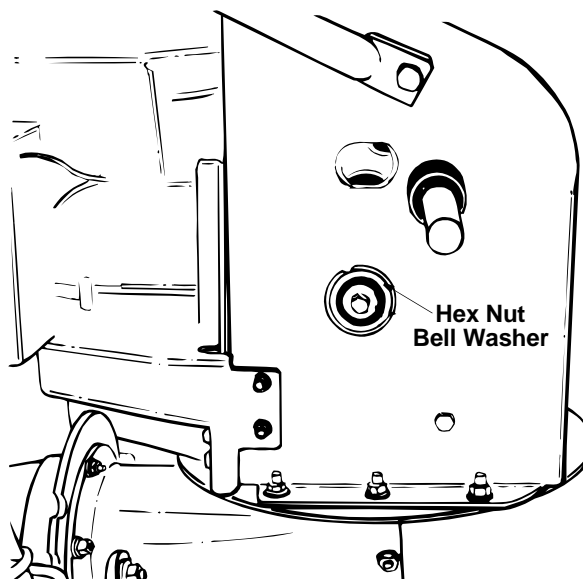

Figure 33

## SECTION 11: OFF-SEASON STORAGE



**WARNING:** Never store engine with fuel in tank indoors or in poorly ventilated areas, where fuel fumes may reach an open flame, spark or pilot light as on a furnace, water heater, clothes dryer or other gas appliance.

1. If unit is to be stored over 30 days, prepare the engine for storage as instructed in the separate engine operator's manual included with your unit.

2. Remove all dirt from exterior of engine and equipment.
3. Follow lubrication recommendations in section 9.

**NOTE:** When storing any type of power equipment in a poorly ventilated or metal storage shed, care should be taken to rust proof the equipment. Using a light oil or silicone, coat the equipment, especially any chains, springs, bearings and cables.

## SECTION 12: TROUBLE SHOOTING GUIDE

Trouble	Possible Cause(s)	Corrective Action
Engine fails to start	Fuel tank empty, or stale fuel. Blocked fuel line. Choke not in ON position Faulty spark plug. Key not in switch on engine. Spark plug wire disconnected. Primer button not depressed. Fuel shut-off valve closed (if so equipped). Improper gasoline and oil mixture.	Fill tank with clean, fresh gasoline. Fuel will not last over thirty days unless a fuel stabilizer is used. Clean fuel line. Move switch to ON position Clean, adjust gap or replace. Insert key. Connect spark plug wire.  Refer to the engine manual packed with your unit. Open fuel shut-off valve.  Refer to the engine manual packed with your unit.
Engine runs erratic**	Unit running on CHOKE. Blocked fuel line or stale fuel.  Water or dirt in fuel system. Carburetor out of adjustment.	Move choke lever to OFF position. Clean fuel line; fill tank with clean fresh gasoline. Fuel will not last over thirty days unless a fuel stabilizer is used. Drain fuel tank. Refill with fresh fuel. Refer to the engine manual packed with your unit or have carburetor adjusted by an authorized service dealer.
Loss of power	Spark plug wire loose. Gas cap vent hole plugged. Exhaust port plugged.	Connect and tighten spark plug wire. Remove ice and snow from cap. Be certain vent hole is clear. Clean-see Maintenance section of engine manual.
Engine overheats	Carburetor not adjusted properly.	Refer to the engine manual packed with your unit or have carburetor adjusted by an authorized service dealer.
Excessive vibration	Loose parts or damaged auger.	Stop engine immediately and disconnect spark plug wire. Tighten all bolts and nuts. Make all necessary repairs. If vibration continues, have unit serviced by an authorized service dealer.
Unit fails to propel itself	Incorrect adjustment of drive cable. Drive belt loose or damaged.	Adjust drive cable. Refer to Adjustment section of this manual. Replace drive belt. Refer to Belt Replacement in Maintenance section of this manual.
Unit fails to discharge snow	Discharge chute clogged.  Foreign object lodged in auger. Incorrect adjustment of drive cable. Drive belt loose or damaged.	Stop engine immediately and disconnect spark plug wire. Clean discharge chute and inside of auger housing. Stop engine immediately and disconnect spark plug wire. Remove object from auger. Adjust drive cable. Refer to Adjustment section of this manual. Replace drive belt. Refer to Belt Replacement in Maintenance section of this manual.

**Note:** For repairs beyond the minor adjustments above, contact your local authorized service dealer.

# Gear Assembly

All Models

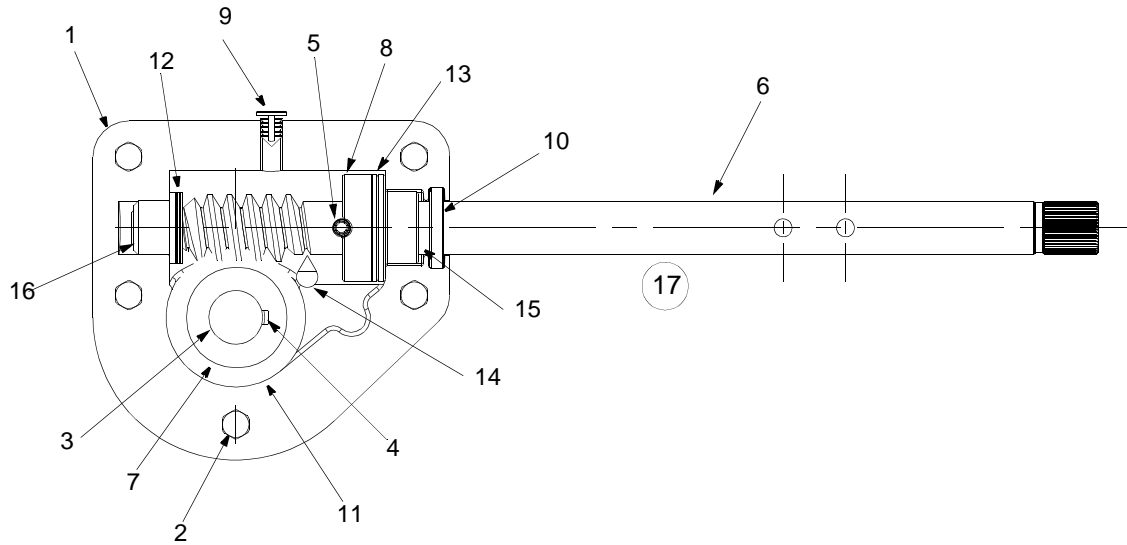

REF. NO.	PART NO.	DESCRIPTION	REF. NO.	PART NO.	DESCRIPTION
1	618-0123	Housing—L.H.	9	721-0325	Plug
	618-0124	Housing—R.H.	10	721-0327	Seal-Oil
2	710-0642	Hex Screw 1/4-20 x .75	11	736-0351	Washer-Flat
3	711-0908	Spiral Axle 24"	12	736-0369	Washer-Flat
	711-0909	Spiral Axle 26"	13	736-0445	Washer-Flat
	711-0910	Spiral Axle 28"	14	737-0168	Grease
4	714-0161	Key	15	741-0662	Bearing-Flange
5	715-0143	Pin-Spiral	16	741-0663	Bearing-Flange
6	717-0526	Shaft-Worm	17	618-0120	Ass'y. Complete 24"
7	717-0528	Gear-Worm		618-0121	Ass'y. Complete 26"
8	718-0186	Collar-Thrust		618-0122	Ass'y. Complete 28"

# Blower Housing

All Models

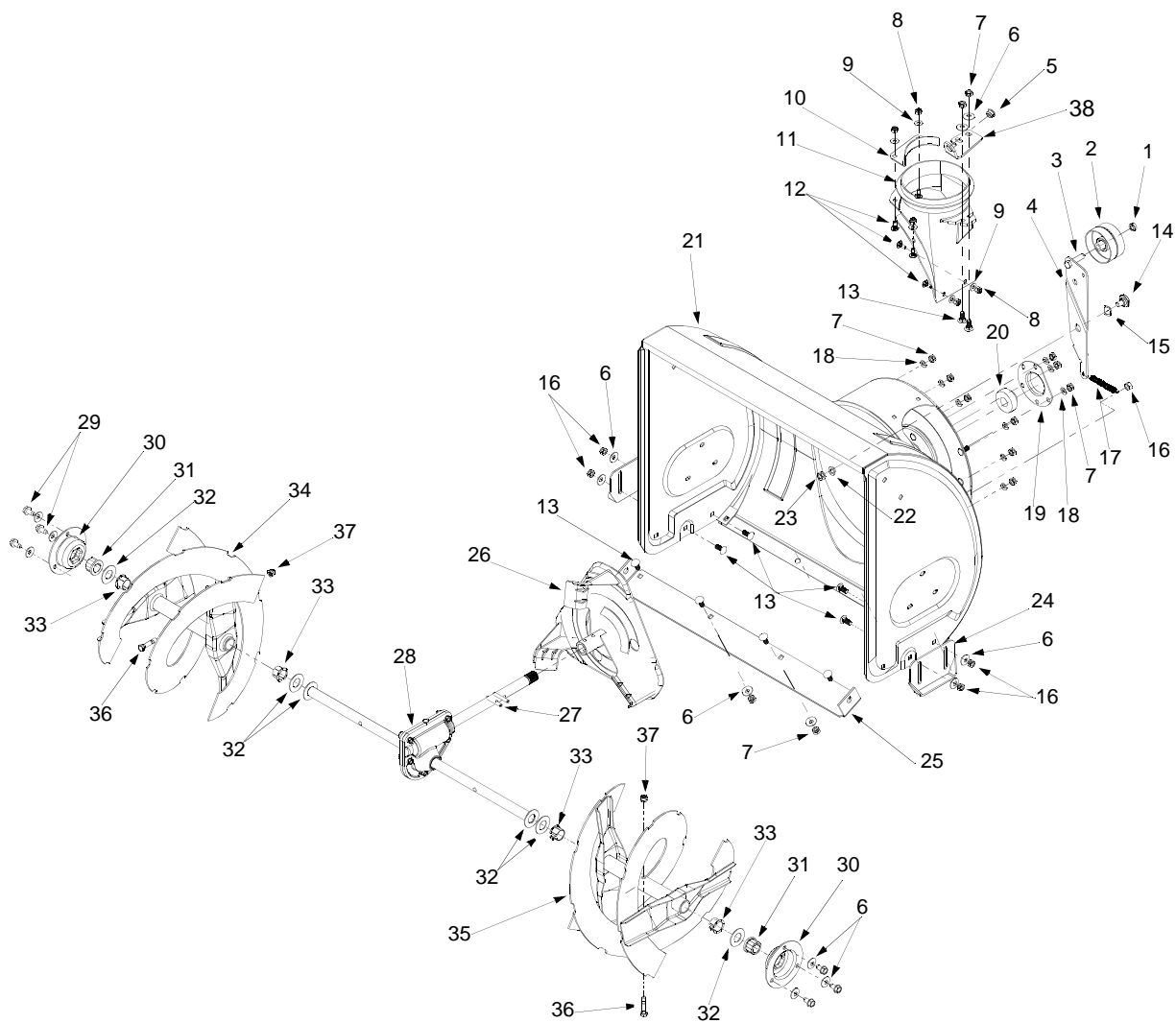

# Blower Housing

REF. NO.	PART NO.	DESCRIPTION	REF. NO.	PART NO.	DESCRIPTION
1	712-0116	Lock Jam Nut 3/8-24	23	712-0798	Hex Nut 3/8-16
2	756-0178	Flat Idler	24	784-5580	Slide Shoe
3	784-5632	Auger Idler Arm	25	784-5581A	24" Shave Plate
4	710-0459A	Hex Cap Screw 3/8-24 x 1.50		784-5579A	26" Shave Plate
5	741-0475	Bushing		784-5575	30" Shave Plate
6	736-0242	Bell Washer	26	684-0065	Impeller Assembly
7	712-3010	Hex Nut 5/16-18	27	715-0114	Pin
8	712-0324	Hex Lock Nut 1/4-20	28	618-0120	24" Gear Assembly
9	736-0463	Flat Washer		618-0121	26" Gear Assembly
10	705-5226	Reinforcement Chute		618-0122	28" Gear Assembly
11	731-1379	Chute Adapter	29	710-0604	Hex Washer Screw 5/16-18
12	710-0134	Carriage Screw 1/4-20 x .62	30	784-5618	Bearing Housing
13	710-0451	Carriage Bolt 5/16-18	31	741-0245	Hex Flange Bearing
14	738-0281	Shoulder Screw	32	736-0188	Flat Washer
15	736-0174	Wave Washer	33	741-0493A	Flange Bushing
16	712-3068	Hex Nut 5/16-18	34	605-5188	Spiral 24" RH
17	732-0611	Extension Spring		605-5192	Spiral 26" RH
18	736-0119	Lock Washer 5/16		605-5196	Spiral 28" RH
19	05931	Bearing Housing	35	605-5189	Spiral 24" LH
20	741-0309	Ball Bearing		605-5193	Spiral 26" LH
21	684-0039B	24" Housing Assembly		605-5197	Spiral 28" LH
	684-0040B	26" Housing Assembly	36	710-0890A	Shear Bolt 5/16-18 x 1.5
	684-0041B	28" Housing Assembly	37	712-0429	Lock Nut 5/16-18
22	736-0169	Lock Washer 3/8	38	784-5647	Chute Crank Bracket

# Handle Assembly

All Models

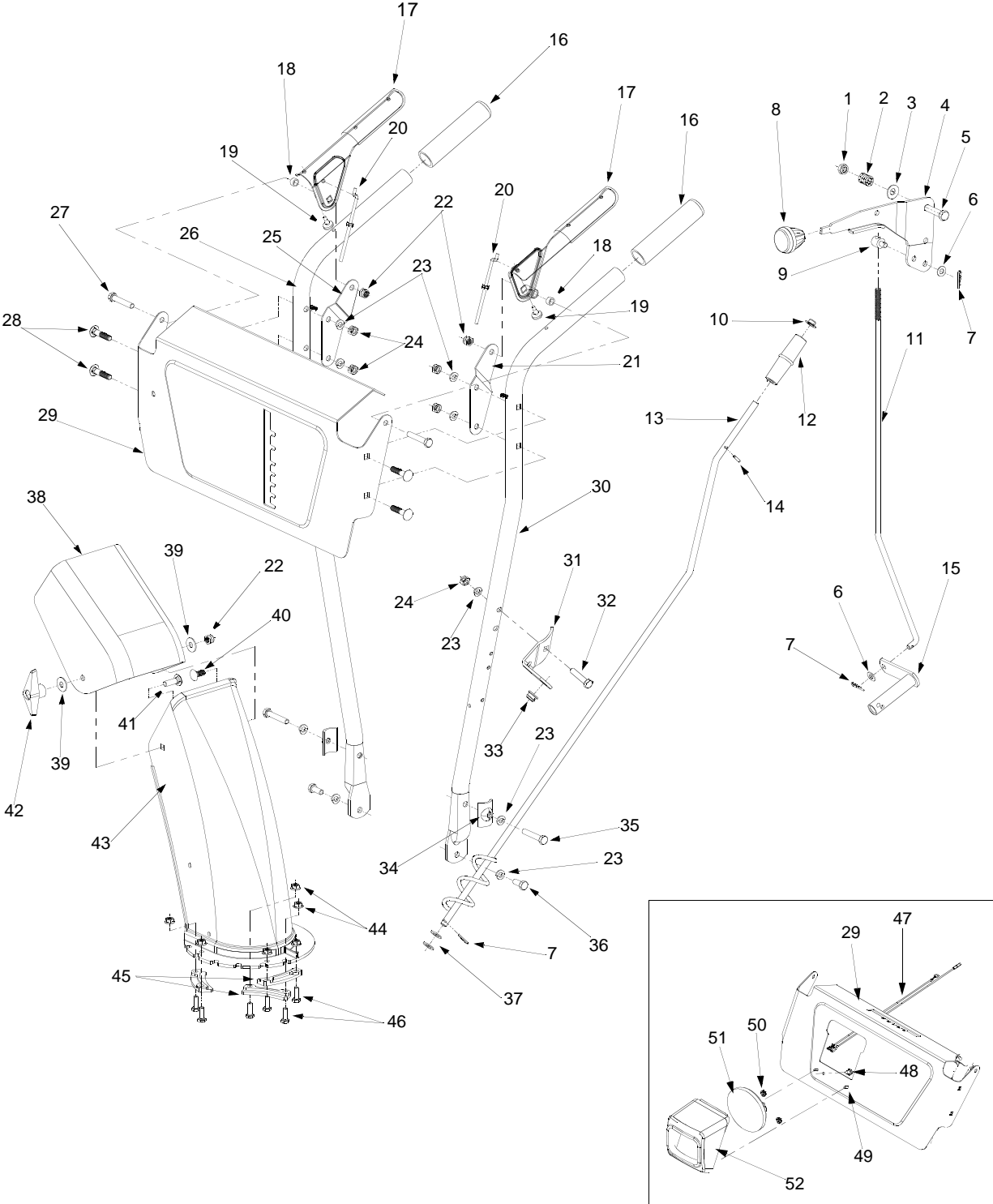

# Handle Assembly

REF. NO.	PART NO.	DESCRIPTION	REF. NO.	PART NO.	DESCRIPTION
1	712-0116	Jam Lock Nut 3/8-24	27	710-3180	Hex Cap Screw 5/16-18 x 1.75
2	732-0193	Compression Spring	28	710-0262	Carriage Bolt 5/16-18 x 1.50
3	736-0105	Bell Washer	29	684-0105	Control Panel Assy - 2 Style
4	784-5619A	Shift Handle		684-0106	Control Panel Assy - 4 Style
5	710-0459A	Hex Cap Screw 3/8-24	30	749-0911A	Handle LH
6	736-0264	Flat Washer	31	784-5678	Chute Crank Bracket
7	714-0104	Cotter Pin	32	710-0805	Hex Cap Screw 5/16/18 x 1.50
8	720-0232	Shift Knob	33	741-0475	Plastic Bushing
9	711-0677	Ferrule	34	784-5599	Handle Tab
10	726-0100	Push Cap	35	710-3103	Hex Cap Screw 5/16-18 x 2.0
11	747-0921	Shift Rod	36	710-3008	Hex Cap Screw 5/16-18 x .75
12	720-0201A	Chute Knob	37	736-0185	Flat Washer
13	747-0819	Crank Chute	38	731-0921	Upper Chute
14	715-0138	Pin	39	736-0159	5/16 Washer
15	684-0008A	Shift Arm Assy	40	710-0451	Carriage Bolt 5/16-18 x .75
16	720-0274	Grip	41	710-0276	Carriage Screw 5/16-18 x 1.0
17	705-5233	Clutch Lever Assy LH	42	720-0284	Knob
	705-5234	Clutch Lever Assy RH	43	731-1300A	Lower Chute
18	750-1032	Spacer	44	712-3027	Hex Lock Nut 1/4-20
19	735-0199A	Rubber Bumper	45	731-0851A	Flange Keeper
20	746-0778	Cable	46	710-3015	Hex Cap Screw 1/4-20 x .75
21	705-5275	Lever Bracket LH	47	629-0058	Round Light Harness
22	712-0429	Lock Hex Nut 5/16-18	48	710-1652	Hex Tap Screw 1/4-20 x .625
23	736-0119	Lock Washer 5/16	49	710-1003	Hex Screw
24	712-3010	Hex Nut 5/16-18	50	712-0415	Hex Nut
25	705-5274	Lever Bracket RH	51	725-1300	Headlight 18 Watts
26	749-0910A	Handle RH	52	731-1317	Headlight Cover



# Frame Assembly

All Models

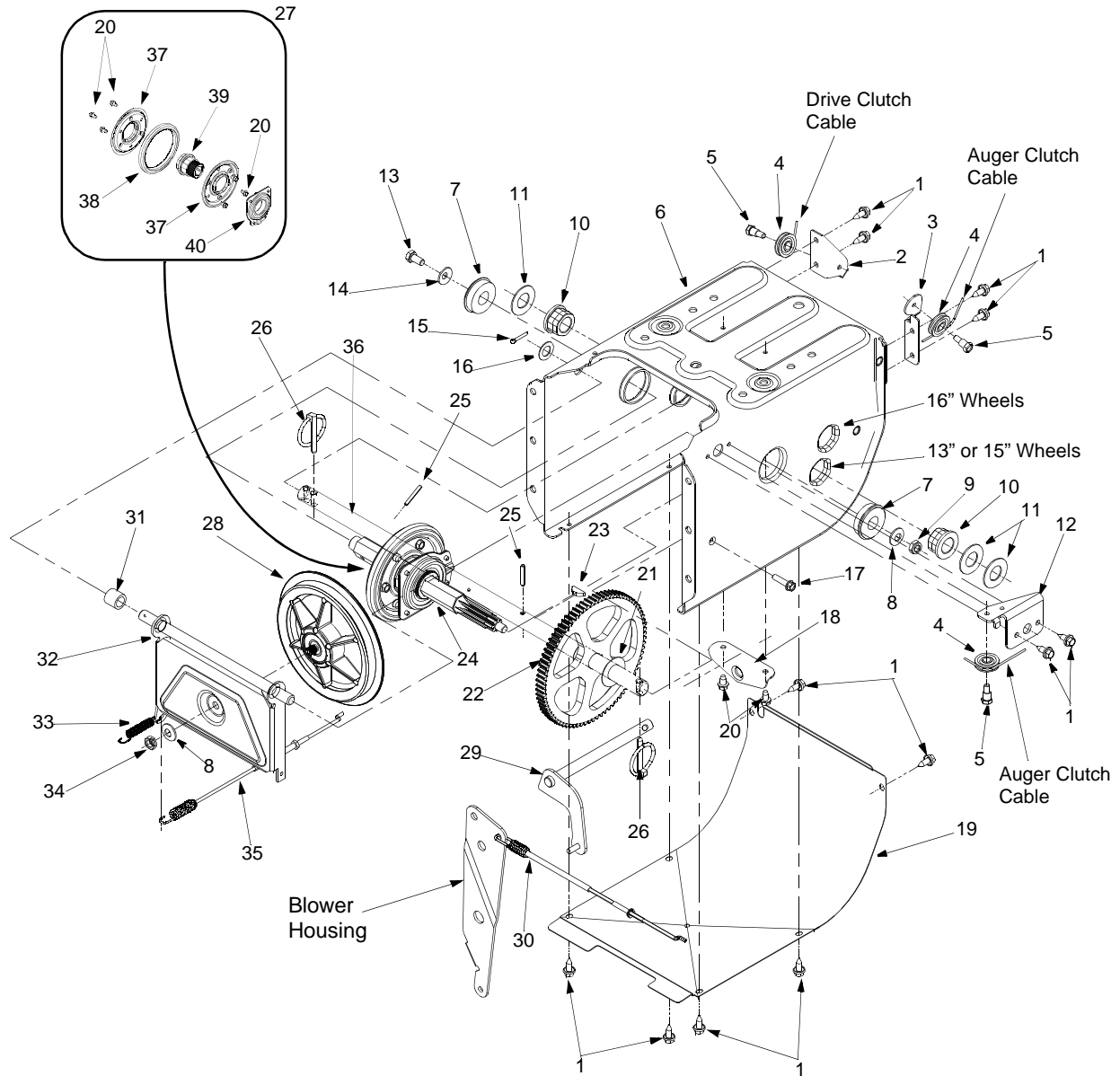

# Frame Assembly

REF. NO.	PART NO.	DESCRIPTION	REF. NO.	PART NO.	DESCRIPTION
1	710-1652	Hex Screw	22	717-1445	Gear
2	784-5688	Drive Cable Guide Bracket	23	714-0126	Key
3	784-5687	Auger Clutch Cable Bracket	24	717-1444	7-Tooth Shaft
4	756-0625	Roller Cable	25	715-0249	Roll Pin
5	738-0924	Hex Screw 1/4-28	26	714-0143	Klik Pin
6	684-0030	Frame Assembly	27	684-0042B	Friction Wheel Assembly
7	741-0563	Ball Bearing	28	656-0012A	Friction Disc Wheel
8	736-0105	Bell Washer	29	684-0013B	Wheel Shift Rod Assembly
9	712-0116	Lock Jam Nut	30	746-0897	Drive Cable
10	741-0598	Hex Flange Bearing	31	748-0190	Spacer
11	736-0188	Flat Washer	32	684-0021	Friction Wheel Bracket Assembly
12	784-5689A	Front Support Guide Bracket	33	732-0264	Extension Spring
13	710-0538	Lock Hex Screw	34	712-0711	Jam Nut 3/8-24
14	736-0242	Bell Washer .340 ID x .872 OD	35	746-0898	Drive Cable
15	714-0474	Cotter Pin	36	738-0869	Axle 13" Wheels
16	736-0160	Flat Washer .536 ID x .930 OD		738-0830	Axle 16" Wheels
17	710-0788	Hex Washer Screw 1/4-20	37	784-5617A	Friction Plate
18	784-5590	Frame Shift Bracket	38	735-0243	Friction Wheel Rubber
19	784-5638	Frame Cover	39	718-0301A	Friction Wheel Hub
20	710-0599	Hex Washer Screw 1/4-20	40	618-0063	Friction Wheel Bearing
21	736-0351	Flat Washer .760 ID x .50 OD			

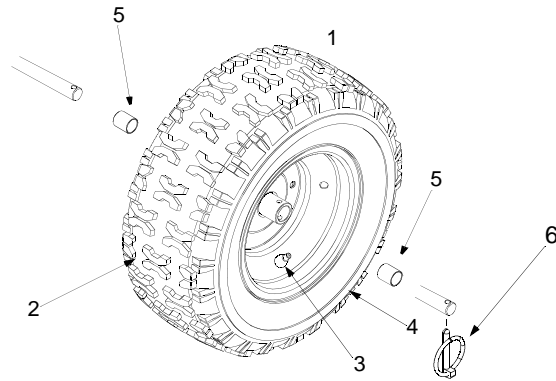

Wheel Assembly						
SIZE	REF. NO. 1 WHEEL ASS'Y COMPLETE	REF. NO. 2 TIRE ONLY	REF. NO. 3 AIR VALVE	REF. NO. 4 RIM ONLY	REF. NO. 5 SLEEVE BEARING (2)	REF. NO 6 Klik Pin
13 x 4	634-0114	734-1732	734-0255	734-1713	741-0401	714-0143
13 x 5	734-1714	734-1527	734-0255	734-1713	741-0401	714-0143
16 x 6.5	734-1712	734-1525	734-0255	734-1711	741-0401	714-0143

# Engine and V-Belts

614E

**IMPORTANT:** For a proper working machine, use Factory Approved Parts.

**V-BELTS** are specially designed to engage and disengage safely. A substitute (non OEM) V-Belt can be dangerous by not disengaging completely.

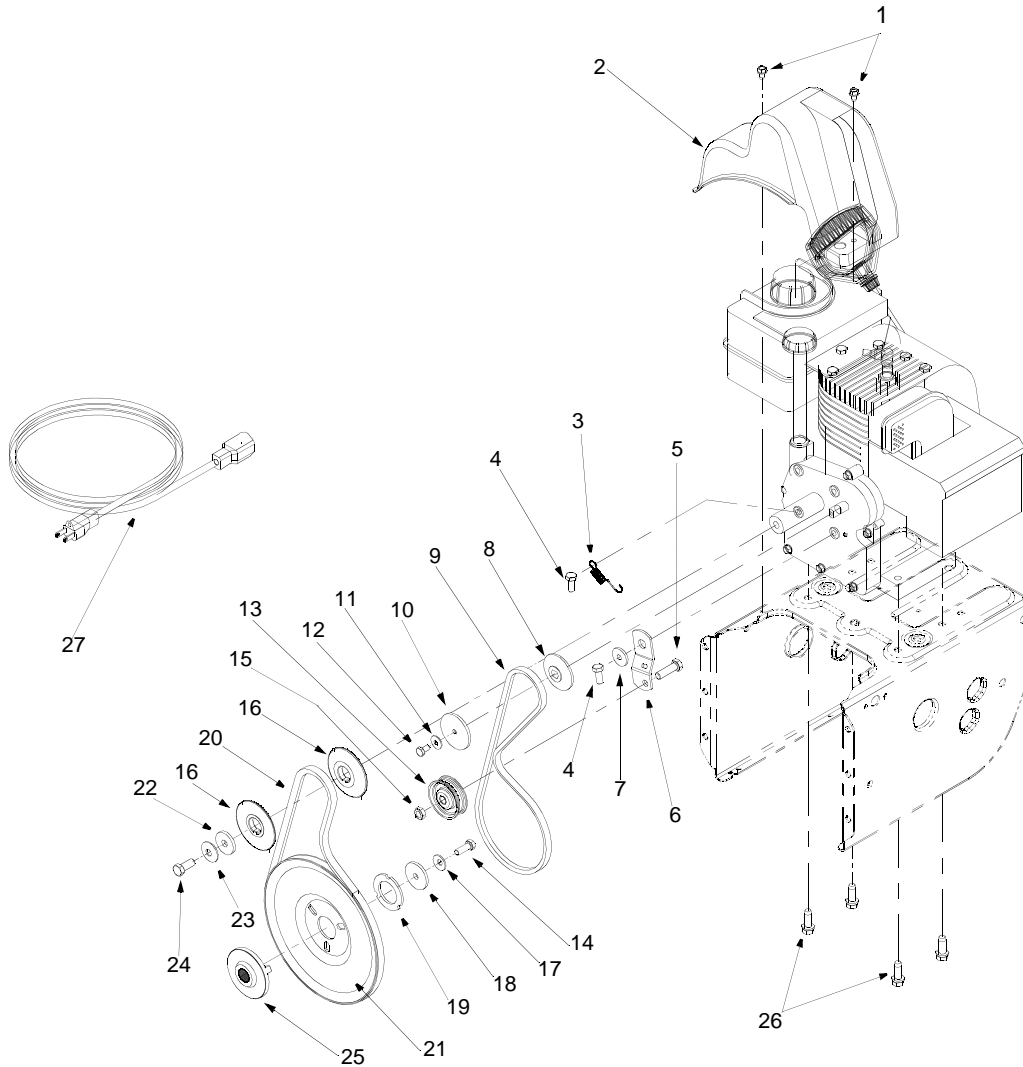

REF. NO.	PART NO.	DESCRIPTION	REF. NO.	PART NO.	DESCRIPTION
1	710-0599	Hex Washer Screw 1/4-20 x.5	15	712-0181	Lock Jam Nut 3/8-16
2	731-1324	Belt Cover	16	756-0569	Pulley Half
3	732-0339	Extension Spring	17	736-0242	Bell Washer
4	710-0627	Hex Screw 5/16-24 x .75	18	736-0505	Flat Washer
5	710-3005	Hex Cap Screw 3/8-16 x 1.25	19	736-0507	Washer
6	05896A	Drive Clutch Bracket	20	754-0430	Belt
7	748-0234	Shoulder Spacer	21	756-0967	Auger Pulley
8	756-0985	Pulley Half	22	736-0247	Flat Washer
9	754-0343	V-Belt	23	736-0331	Bell Washer
10	756-0984	Pulley Half	24	710-0696	Hex Cap Screw 3/8-24
11	736-0270	Bell Washer	25	748-0360	Pulley
12	710-0230	Hex Cap Screw 1/4-28 x .50	26	710-0654A	Hex Washer Screw 3/8-16 x 1.0
13	756-0313	Flat Idler	27	629-0071	Extension Cord
14	710-1245	Lock Cap Screw 5/16-24		OEM-390-986	Electric Start Kit

# Engine and V-Belts

E642E, E644E, E664F

**IMPORTANT:** For a proper working machine, use Factory Approved Parts.

**V-BELTS** are specially designed to engage and disengage safely. A substitute (non OEM) V-Belt can be dangerous by not disengaging completely.

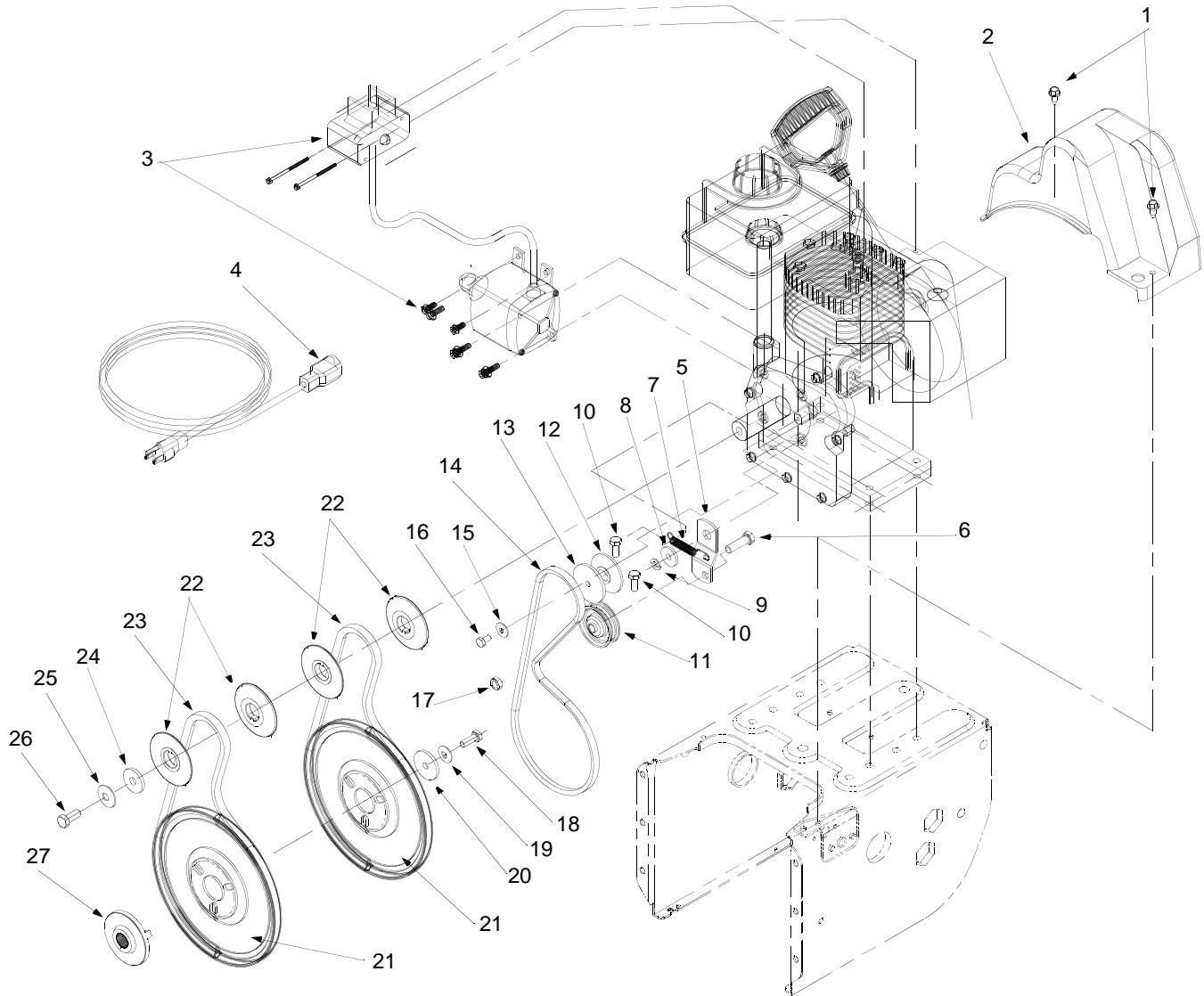

REF. NO.	PART NO.	DESCRIPTION	REF. NO.	PART NO.	DESCRIPTION
1	710-0896	Hex Washer Screw 1/4-14 x .625	15	736-0270	Bell Washer
2	731-1324	Belt Cover	16	710-0230	Hex Cap Screw 1/4-28 x .50
3	831-00067	Electric Start	17	712-0181	Lock Jam Nut 3/8-16
4	629-0071	Extension Cord	18	710-1245	Lock Hex Cap Screw 5/16-24 x .87
5	05896A	Drive Clutch Bracket	19	736-0242	Bell Washer
6	710-3005	Hex Cap Screw 3/8-16 x 1.25	20	736-0505	Flat Washer
7	732-0710	Extension Spring	21	756-0967	Auger Pulley
8	748-0234	Shoulder Spacer	22	756-0569	Pulley Half
9	736-0119	Lock Washer 5/16	23	754-0430	V-Belt
10	710-0627	Lock Hex Cap Screw 5/16-24 x .75	24	736-0247	Flat Washer
11	756-0313	Flat Idler	25	736-0331	Bell Washer
12	756-0987	Pulley Half	26	710-0696	Hex Cap Screw 3/8-24 x .875
13	756-0986	Pulley Half	27	748-0360	Adapter Pulley
14	754-0346	V-Belt		OEM-390-987	Electric Start Kit

# Engine and V-Belts

E6A4E, E662H

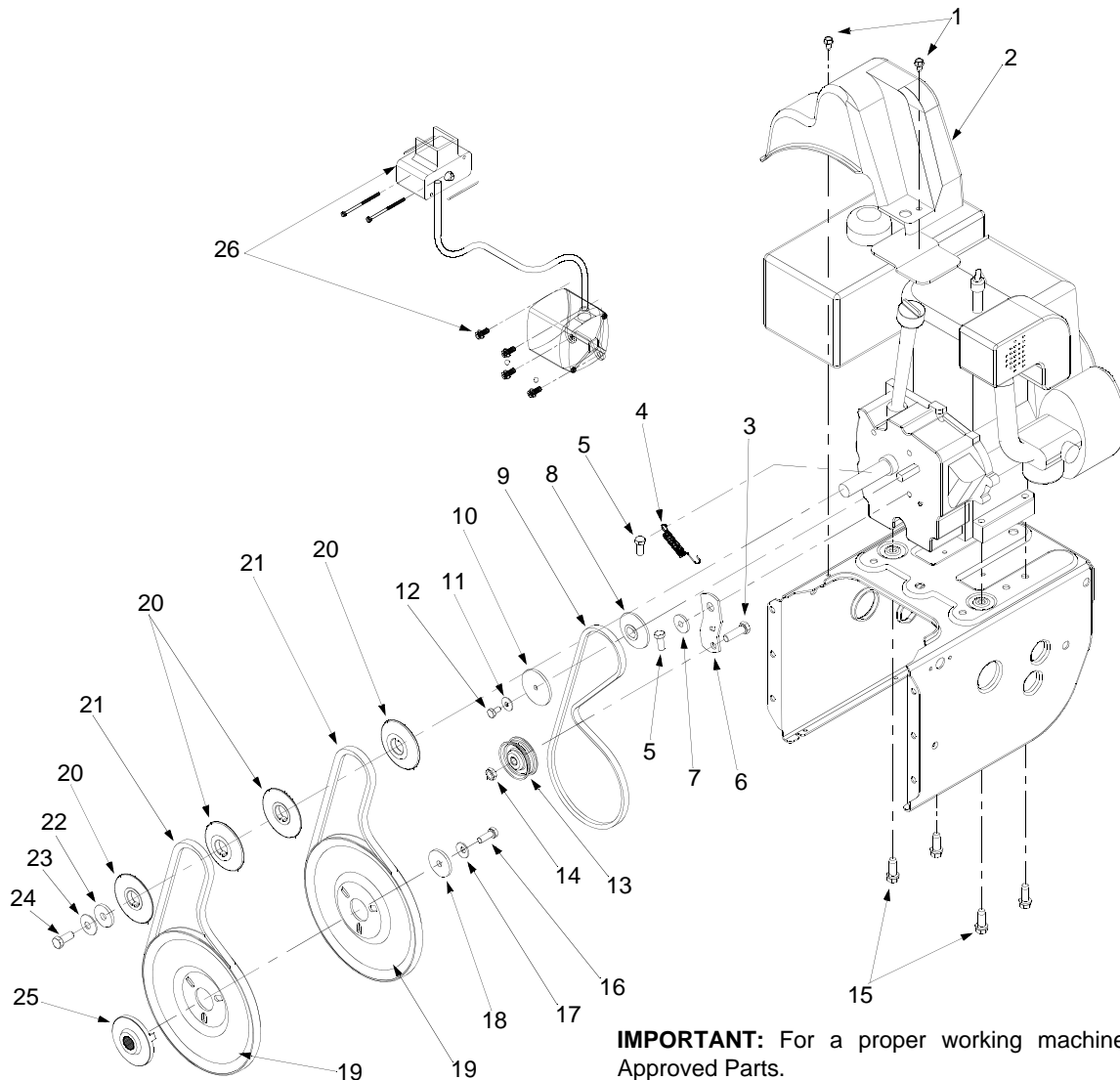

**IMPORTANT:** For a proper working machine, use Factory Approved Parts.

**V-BELTS** are specially designed to engage and disengage safely. A substitute (non OEM) V-Belt can be dangerous by not disengaging completely.

REF. NO.	PART NO.	DESCRIPTION	REF. NO.	PART NO.	DESCRIPTION
1	710-0599	Hex Washer Screw 1/4-20 x .50	14	712-0181	Lock Jam Nut 3/8-16
2	731-1324	Belt Cover	15	710-0854A	Hex Washer Screw 3/8-16 x 1.0
3	710-3005	Hex Cap Screw 3/8-16 x 1.25	16	710-1245	Hex Lock Screw 5/16-24 x .875
4	732-0710	Spring Extension	17	736-0242	Bell Washer .340 ID x .872 OD
5	710-0627	Hex Screw 5/16-24 x .75	18	736-0505	Flat Washer .341 ID x .50 OD
6	05896A	Drive Clutch Idler Bracket	19	756-0967	Pulley Auger
7	748-0234	Shoulder Spacer	20	756-0589	Pulley Half
8	756-0987	Pulley Half	21	754-0430	V-Belt
9	754-0430	Belt	22	736-0247	Flat Washer
10	756-0986	Pulley Half	23	736-0331	Bell Washer .39 ID x 1.13 OD
11	736-0270	Bell Washer	24	710-0696	Hex Cap Screw 3/8-24 x .875
12	710-0230	Hex Cap Screw	25	748-0360	Pulley Adapter
13	756-0313	Flat Idler	26	OEM-390-987	Electric Start





# MANUFACTURER'S LIMITED WARRANTY

For TWO YEARS from the date of retail purchase within the United States of America, its possessions and territories, the manufacturer will, at its option, repair or replace, for the original purchaser, free of charge, any part or parts found to be defective in material or workmanship. This warranty covers units which have been operated and maintained in accordance with the operating instructions furnished with the unit, and which have not been subject to misuse, abuse, commercial use, neglect, accident, improper maintenance or alteration.

Normal wear parts or components thereof are subject to separate terms as noted below in the "No Fault Ninety Day Consumer Warranty" clause.

All normal wear part failures will be covered on this product for a period of 90 days regardless of cause. After 90 days, but within the two year period, normal wear parts failures will be covered ONLY IF caused by defects in material or workmanship of OTHER component parts. Normal wear parts are defined as batteries\*, belts, blades, blade adapters, grass bags, rider deck wheels, seats, snow thrower skid shoes, shave plates and tires.

**How to obtain service:** Warranty service is available, with proof of purchase, through your local authorized service dealer. To locate the dealer in your area, please check the yellow pages or contact the Customer Service Department of the manufacturer, P. O. Box 368022, Cleveland, Ohio 44136-9722. Phone 1-800-800-7310. The return of a complete unit will not be accepted by the factory unless prior written permission has been extended by the service department of the manufacturer.

**Transportation charges:** Transportation charges for the movement of any power equipment unit or attachment are the responsibility of the purchaser.

**Units exported out of the United States:** The manufacturer does not extend any warranty for products sold or exported outside of the United

States of America, its possessions and territories, except those sold through the manufacturer's authorized channels of export distribution.

## **Other Warranties:**

1. The engine or component parts thereof carry separate warranties from their manufacturers. Please refer to the applicable manufacturer's warranty on these items.
2. \*Batteries are covered by a 90-day replacement warranty.
3. Log splitter pumps, valves and cylinders or component parts thereof are covered by a one year warranty.
4. All other warranties, express or implied, including any implied warranty of merchantability or fitness for a particular purpose, are hereby expressly disclaimed in their entirety.
5. The provisions as set forth in this warranty provide the sole and exclusive remedy of the manufacturer's obligations arising from the sales of its products. The manufacturer will not be liable for incidental or consequential loss or damage.

**How state law relates to this warranty:** This limited warranty gives you specific legal rights, and you may also have other rights which vary from state to state. Certain disclaimers are not allowed in some states and therefore they may not apply to you under all circumstances.

**NOTE:** This warranty does not cover routine maintenance items such as lubricants, filters, blade sharpening and tune-ups, or adjustments such as brake adjustments, clutch adjustments or deck adjustments. Nor does this warranty cover normal deterioration of the exterior finish due to use or exposure.