

OPERATOR'S MANUAL

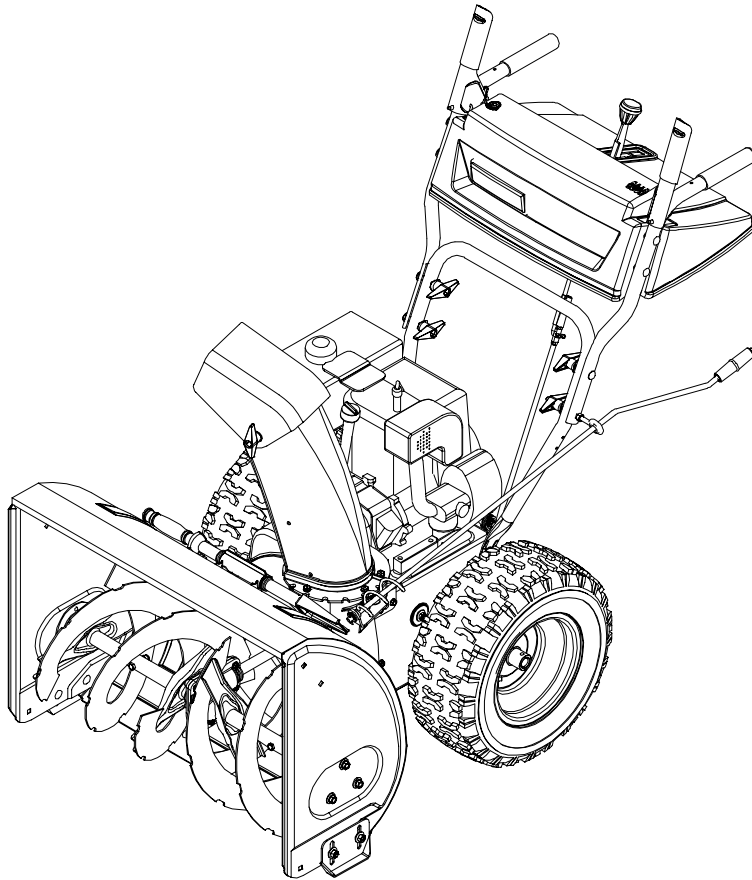

Snow Thrower

**Models
643 & 663**

IMPORTANT: READ SAFETY RULES AND INSTRUCTIONS CAREFULLY

Warning: This unit is equipped with an internal combustion engine and should not be used on or near any unimproved forest-covered, brush-covered or grass-covered land unless the engine's exhaust system is equipped with a spark arrester meeting applicable local or state laws (if any). If a spark arrester is used, it should be maintained in effective working order by the operator. In the State of California the above is required by law (Section 4442 of the California Public Resources Code). Other states may have similar laws. Federal laws apply on federal lands. A spark arrester for the muffler is available through your nearest engine authorized service dealer or contact the service department, P.O. Box 361131 Cleveland, Ohio 44136-0019.

MTD LLC P.O. BOX 361131 CLEVELAND, OHIO 44136-0019

PRINTED IN U.S.A.

FORM NO. 769-00377
(6/02)

TABLE OF CONTENTS

Content	Page
Important Safe Operation Practices.....	3
Assembling Your Snow Thrower	5
Know Your Snow Thrower	6
Operating Your Snow Thrower	7
Making Adjustments	10
Maintaining Your Snow Thrower.....	12
Servicing Your Snow Thrower	13
Troubleshooting.....	16
Parts List.....	17

FINDING MODEL NUMBER

This Operator's Manual is an important part of your new Snow Thrower. It will help you assemble, prepare and maintain the unit for best performance. Please read and understand what it says.



Before you start assembling your new equipment, please locate the model plate on the equipment and copy the information from it in the space provided below. The information on the model plate is very important if you need help from your local authorized dealer.

You can locate the model number by looking at the lower frame cover on the rear of your snow thrower. A sample model plate is explained below. For future reference, please copy the model number and the serial number of the equipment in the space below.



Copy the model number here: _____

Copy the serial number here: _____

ENGINE INFORMATION

The engine manufacturer is responsible for all engine-related issues with regards to performance, power-rating, specifications, warranty and service. Please refer to the engine manufacturer's Owner's/Operator's Manual packed separately with your unit for more information.

CALLING CUSTOMER SUPPORT

Please do NOT return the unit to the retailer from which it was purchased, without first contacting Customer Support.

Should you have difficulty assembling this product or have any questions regarding the controls, operation or maintenance of this unit, please call the Customer Support Department.



Call **1- (330) 220-4MTD (4683)** or **1- (800)-800-7310** to reach a Customer Support representative. Please have your unit's model number and serial number ready when you call. See previous section to locate this information. You will be asked to enter the serial number in order to process your call.

For more details about your unit, visit our website at www.mtdproducts.com

SECTION 1: IMPORTANT SAFE OPERATION PRACTICES



This symbol points out important safety instructions, which if not followed, could endanger the personal safety and/or property of yourself and others. Read and follow all instructions in this manual before attempting to operate this machine. Failure to comply with these instructions may result in personal injury. When you see this symbol—**heed its warning**.



WARNING: Engine Exhaust, some of its constituents, and certain vehicle components contain or emit chemicals known to the State of California to cause cancer, birth defects or other reproductive harm.



DANGER: This machine was built to be operated according to the rules for safe operation in this manual. As with any type of power equipment, carelessness or error on the part of the operator can result in serious injury. This machine is capable of amputating hands and feet and throwing objects. Failure to observe the following safety instructions could result in serious injury or death.

TRAINING

1. Read, understand, and follow all instructions on the machine and in the manual(s) before attempting to assemble and operate. Keep this manual in a safe place for future and regular reference and for ordering replacement parts.
2. Be familiar with all controls and their proper operation. Know how to stop the machine and disengage them quickly.
3. Never allow children under 14 years old to operate this machine. Children 14 years old and over should read and understand the operation instructions and safety rules in this manual and should be trained and supervised by a parent.
4. Never allow adults to operate this machine without proper instruction.
5. Thrown objects can cause serious personal injury. Plan your snow-throwing pattern to avoid discharge of material toward roads, bystanders and the like.
6. Keep bystanders, helpers, pets and children at least 75 feet from the machine while it is in operation. Stop machine if anyone enters the area.
7. Exercise caution to avoid slipping or falling, especially when operating in reverse.
6. Disengage all clutch levers before starting the engine.
7. Never attempt to make any adjustments while engine is running, except where specifically recommended in the operator's manual.
8. Let engine and machine adjust to outdoor temperature before starting to clear snow.
9. To avoid personal injury or property damage use extreme care in handling gasoline. Gasoline is extremely flammable and the vapors are explosive. Serious personal injury can occur when gasoline is spilled on yourself or your clothes, which can ignite. Wash your skin and change clothes immediately.
 - a. Use only an approved gasoline container.
 - b. Extinguish all cigarettes, cigars, pipes and other sources of ignition.
 - c. Never fuel machine indoors.
 - d. Never remove gas cap or add fuel while the engine is hot or running.
 - e. Allow engine to cool at least two minutes before refueling.
 - f. Never over fill fuel tank. Fill tank to no more than 1/2 inch below bottom of filler neck to provide space for fuel expansion.
 - g. Replace gasoline cap and tighten securely.
 - h. If gasoline is spilled, wipe it off the engine and equipment. Move machine to another area. Wait 5 minutes before starting the engine.
 - i. Never store the machine or fuel container inside where there is an open flame, spark or pilot light (e.g. furnace, water heater, space heater, clothes dryer etc.).
 - j. Allow machine to cool at least 5 minutes before storing.

PREPARATION

1. Thoroughly inspect the area where the equipment is to be used. Remove all doormats, newspapers, sleds, boards, wires and other foreign objects, which could be tripped over or thrown by the auger/impeller.
2. Always wear safety glasses or eye shields during operation and while performing an adjustment or repair to protect your eyes. Thrown objects which ricochet can cause serious injury to the eyes.
3. Do not operate without wearing adequate winter outer garments. Do not wear jewelry, long scarves or other loose clothing, which could become entangled in moving parts. Wear footwear which will improve footing on slippery surfaces.
4. Use a grounded three-wire extension cord and receptacle for all units with electric start engines.
5. Adjust collector housing height to clear gravel or crushed rock surfaces.

OPERATION

1. Do not put hands or feet near rotating parts, in the auger/impeller housing or discharge chute. Contact with the rotating parts can amputate hands and feet.
2. The auger/impeller clutch lever is a safety device. Never bypass its operation. Doing so makes the machine unsafe and may cause personal injury.
3. The clutch levers must operate easily in both directions and automatically return to the disengaged position when released.

4. Never operate with a missing or damaged discharge chute. Keep all safety devices in place and working.
5. Never run an engine indoors or in a poorly ventilated area. Engine exhaust contains carbon monoxide, an odorless and deadly gas.
6. Do not operate machine while under the influence of alcohol or drugs.
7. Muffler and engine become hot and can cause a burn. Do not touch.
8. Exercise extreme caution when operating on or crossing gravel surfaces. Stay alert for hidden hazards or traffic.
9. Exercise caution when changing direction and while operating on slopes.
10. Plan your snow-throwing pattern to avoid discharge towards windows, walls, cars etc. Thus, avoiding possible property damage or personal injury caused by a ricochet.
11. Never direct discharge at children, bystanders and pets or allow anyone in front of the machine.
12. Do not overload machine capacity by attempting to clear snow at too fast of a rate.
13. Never operate this machine without good visibility or light. Always be sure of your footing and keep a firm hold on the handles. Walk, never run.
14. Disengage power to the auger/impeller when transporting or not in use.
15. Never operate machine at high transport speeds on slippery surfaces. Look down and behind and use care when in reverse.
16. If the machine should start to vibrate abnormally, stop the engine, disconnect the spark plug wire and ground it against the engine. Inspect thoroughly for damage. Repair any damage before starting and operating.
17. Disengage all clutch levers and stop engine before you leave the operating position (behind the handles). Wait until the auger/impeller comes to a complete stop before unclogging the discharge chute, making any adjustments, or inspections.
18. Never put your hand in the discharge or collector openings. Always use the clean-out tool provided to unclog the discharge opening. Do not unclog discharge chute while engine is running. Shut off engine and remain behind handles until all moving parts have stopped before unclogging.
19. Use only attachments and accessories approved by the manufacturer (e.g. wheel weights, tire chains, cabs etc.).
20. If situations occur which are not covered in this manual, use care and good judgment. Contact your dealer or

telephone 1-800-800-7310 for assistance and the name of your nearest servicing dealer.

MAINTENANCE AND STORAGE

1. Never tamper with safety devices. Check their proper operation regularly. Refer to the maintenance and adjustment sections of this manual.
2. Before cleaning, repairing, or inspecting machine disengage all clutch levers and stop engine. Wait until the auger/impeller come to a complete stop. Disconnect the spark plug wire and ground against the engine to prevent unintended starting.
3. Check bolts and screws for proper tightness at frequent intervals to keep the machine in safe working condition. Also, visually inspect machine for any damage.
4. Do not change the engine governor setting or over-speed the engine. The governor controls the maximum safe operating speed of the engine.
5. Snow thrower shave plates and skid shoes are subject to wear and damage. For your safety protection, frequently check all components and replace with original equipment manufacturer's (OEM) parts only. "Use of parts which do not meet the original equipment specifications may lead to improper performance and compromise safety!"
6. Check clutch controls periodically to verify they engage and disengage properly and adjust, if necessary. Refer to the adjustment section in this operator's manual for instructions.
7. Maintain or replace safety and instruction labels, as necessary.
8. Observe proper disposal laws and regulations for gas, oil, etc. to protect the environment.
9. Prior to storing, run machine a few minutes to clear snow from machine and prevent freeze up of auger/impeller.
10. Never store the machine or fuel container inside where there is an open flame, spark or pilot light such as a water heater, furnace, clothes dryer etc.
11. Always refer to the operator's manual for proper instructions on off-season storage.



WARNING: Restrict the use of this power machine to persons who read, understand and follow the warnings and instructions in this manual and on the machine.

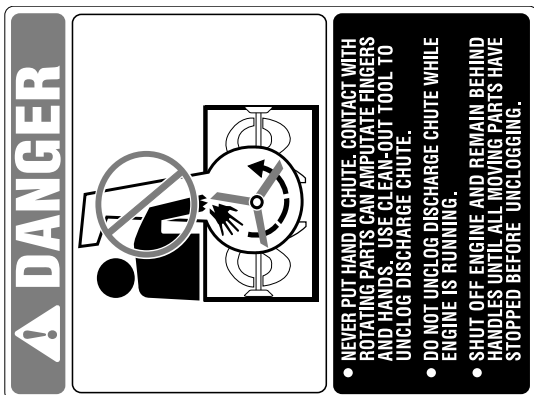

SECTION 2: ASSEMBLING YOUR SNOW THROWER

NOTE: References to right or left side of the snow thrower are determined from behind the unit in the operating position. The “operator’s position” is defined as standing directly behind the snow thrower, facing the handle panel.

Unpacking

- Remove screws from the top sides and ends of the shipping crate.
- Set panel aside to avoid tire punctures or personal injury.
- Remove and discard plastic bag that covers unit.
- Remove any loose parts included with unit (i.e., Operator’s Manual, etc).
- Roll unit out of crate.

Loose Parts

The augers are secured to the auger shaft with two shear bolts and hex lock nuts. If you hit a foreign object or ice jam, the snow thrower is designed so that the bolts may shear. Two replacement shear bolts and nuts are provided for your convenience. Store in a safe place until needed. See Figure 1.

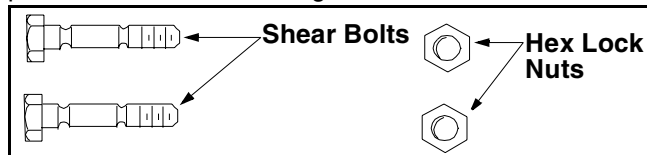

Figure 1

Assembly



WARNING: Disconnect the spark plug wire and ground it against the engine to prevent unintended starting.

- Remove the **lower** two plastic wing nuts, cupped washers and carriage bolts from each side of the lower handle. See Figure 2.

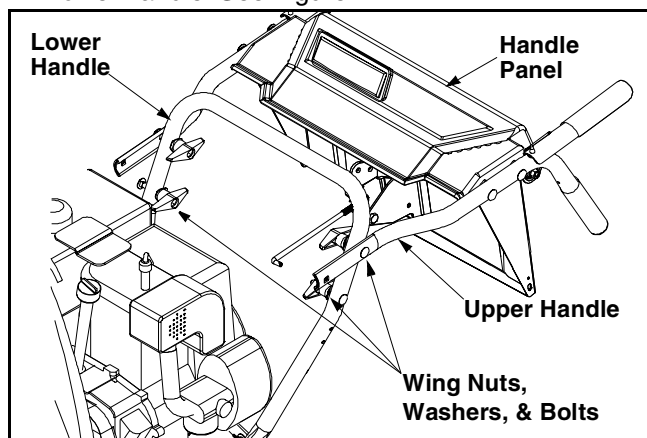

Figure 2

- Raise the upper handle assembly until it locks over the lower handle.
- Look at the lower rear of the snow thrower frame to be sure all the cables are aligned with the cable roller guides.
- Secure the upper handle and lower handle with the two plastic wing nuts, cupped washers and carriage bolts previously removed and tighten the upper two plastic wing nuts. See Figure 3.

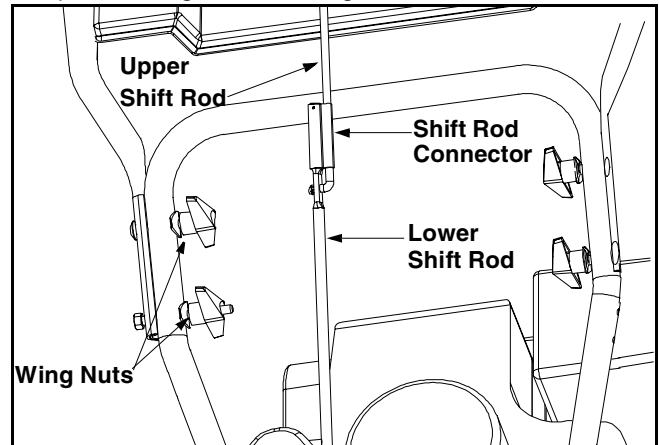

Figure 3

- Slide the shift rod connector down over the end of the lower shift rod. Tap the connector until it **locks** over the lower shift rod. See Figure 3.

NOTE: If the connector is not properly assembled, the shift rod will pivot and you will not be able to change speeds or change directions.

- If not already attached, slip the cables that run from the handle panel to the chute into the cable guide located on top of the engine. See Figure 4.

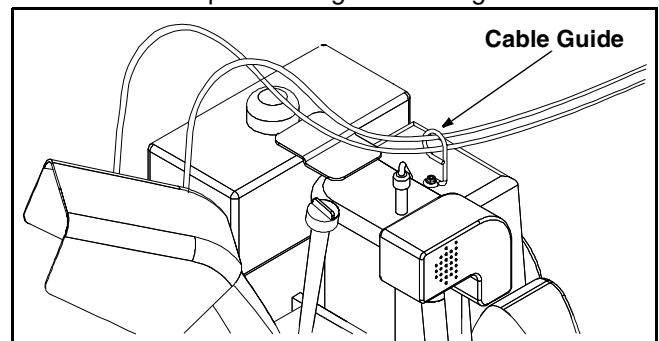

Figure 4

- Unwrap the headlight wire, which is attached to the headlight beneath the handle panel.
- Wind the headlight wire around the right handle until excess slack is removed.
- Plug the wire from the headlight into the wire lead coming from the right side of the engine, beneath the fuel tank.

SECTION 3: KNOW YOUR SNOW THROWER

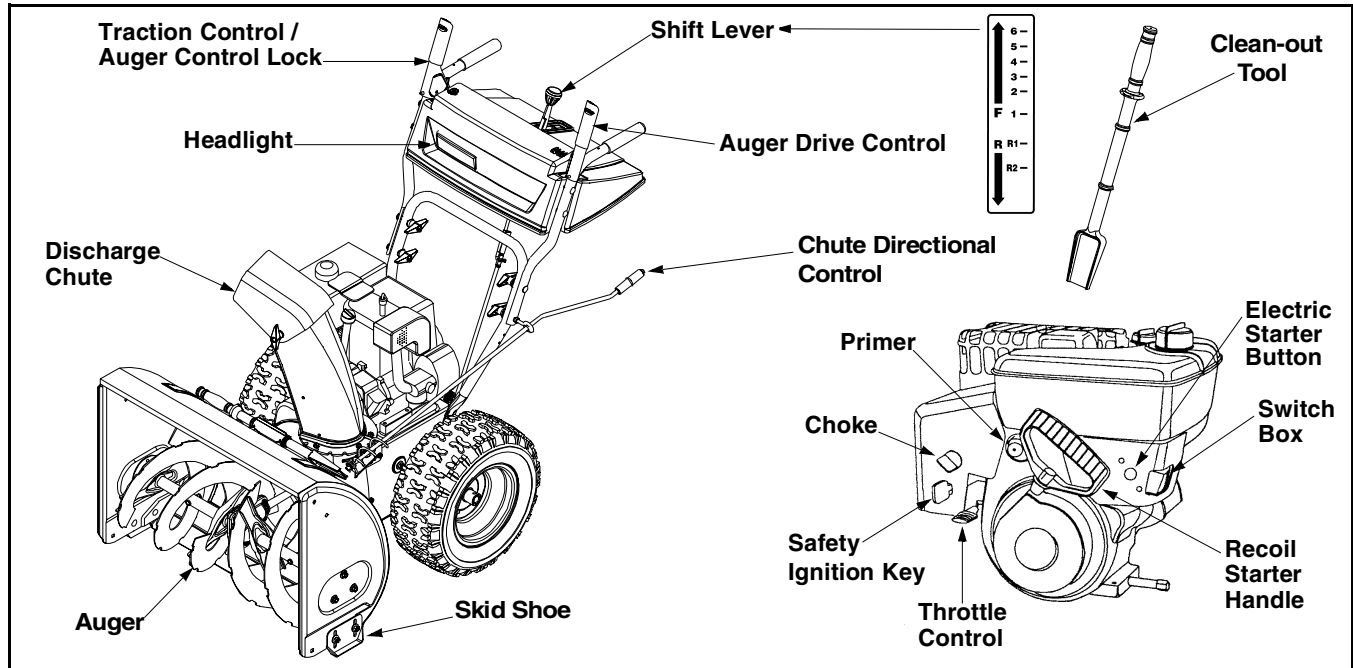

Figure 5



WARNING: Read, understand, and follow all instructions and warnings on the machine and in this manual before operating.

Traction Control / Auger Control Lock

The traction control is located on the right handle. Squeeze the traction control to engage the wheel drive. Release to stop. See Figure 5.

This same lever also locks the auger control so you can turn the chute directional control without interrupting the snow throwing process. If the auger control is engaged along with the traction control, the operator can release the auger control (on the left handle) and the augers will remain engaged. Release the traction control to stop both the augers and track drive (auger control must also be released).

IMPORTANT: Always release tractional control before changing speeds.

Auger Drive Control

The auger drive control is located on the left handle. Squeeze the control grip to engage the augers. Release to stop the snow throwing action. (Traction control must also be released.) See Figure 5.

Skid Shoe

The position of the skid shoe is determined by the condition of the ground from where snow has to be removed. See Figure 5.

Shift Lever

The shift lever is located in the center of the handle panel and is used to determine both ground speed and direction of travel. It can be moved into any of eight positions. See Figure 5.

Forward

Your snow thrower has six forward (F) speeds. Position number one (1) is the slowest. Position number six (6) is the fastest.

Reverse

Your snow thrower has two reverse (R) speeds. R1 is the slower, while R2 is the faster of the two.

IMPORTANT: Always release tractional control before changing speeds.

Chute Directional Control

The chute directional control is located on left side of the snow thrower. See Figure 5.

To change the direction in which snow is thrown, turn chute directional control as follows:

- Crank clockwise to discharge to the left.
- Crank counterclockwise to discharge to the right.

Safety Ignition Key

The safety ignition key must be fully inserted in the switch before the unit will start. Remove the ignition key when the snow thrower is not in use. See Figure 5.

IMPORTANT: Do NOT attempt to turn the key.

Headlight

The headlight is on whenever the engine is running.

Throttle Control

The throttle control is located on the engine. It regulates the speed of the engine and will shut off the engine when pushed down completely. See Figure 5.

Clean-Out Tool

The chute clean-out tool is fastened to the top of the auger housing with a mounting clip. The tool is

designed to clear a clogged discharged chute. Refer to **Operating Your Snow Thrower** section for more detailed information regarding the chute clean-out tool. See Figure 5.



WARNING: Never use your hand to clear a clogged discharged chute. Shut off engine and remain behind handles until all moving parts have stopped before unclogging.

SECTION 4: OPERATING YOUR SNOW THROWER

Before Starting



WARNING: Read, understand, and follow all instructions and warnings on the machine and in this manual before operating.

Gas And Oil Fill-up

Service the engine with gasoline and oil as instructed in the separate engine manual packed with your snow thrower. **Read instructions carefully.**



WARNING: Use extreme care when handling gasoline. Gasoline is extremely flammable and the vapors are explosive. Never fuel machine indoors or while the engine is hot or running. Extinguish cigarettes, cigars, pipes and other sources of ignition.

- A plastic **cup** is provided inside the fuel fill opening on the fuel tank. Remove and discard this cup before filling up the tank. Use the separate fuel tank cap to close after fill-up.

To Start Engine

- Attach spark plug wire to spark plug. Make certain the metal loop on end of the spark plug wire (inside the boot) is fastened securely over the metal tip on the spark plug.
- Make certain the fuel cut-off valve, if your snow thrower is so equipped, is in OPEN position.
- Make certain the auger and drive clutch levers are in the disengaged (released) position.
- Move throttle control up to FAST position. Insert ignition key into slot. Be certain it snaps into place. **Do not turn key.**

NOTE: *Engine will not start unless ignition key is inserted into ignition slot in carburetor cover.*

Electric Starter

- Determine that your house wiring is a three-wire grounded system. Ask a licensed electrician if you are not certain.
- If your house wiring system is not a three-wire grounded system, do not use this electric starter under any conditions.



WARNING: The electric starter is equipped with a grounded three-wire power cord and plug and is designed to operate on 120 volt AC household current. It must be used with a properly grounded three-prong receptacle at all times to avoid the possibility of electric shock. Follow all instructions carefully prior to operating the electric starter.

- If your home electrical system is grounded, but a three-hole receptacle is not available, one should be installed by a licensed electrician before using the electric starter.
- If you have a grounded three-prong receptacle, proceed as follows:
- Rotate choke knob to OFF position and do not prime engine.
- Connect power cord to switch box on engine. Plug the other end of power cord into a three-hole, grounded 120 volt AC receptacle.
- Push starter button on top of the engine to crank engine. As you crank the engine, move choke knob to FULL choke position.
- When engine starts, release starter button, and move choke gradually to OFF. If engine falters, move choke immediately to FULL and then gradually to OFF.
- When disconnecting the power cord, always unplug from the three-prong receptacle first and then from the snow thrower.

Recoil Starter

- Rotate choke knob to FULL choke position (cold engine start). If engine is warm, place choke in OFF position instead of FULL.
- Push primer button two or three times. If engine is warm, push primer button once only.

NOTE: Always cover vent hole in primer button when pushing. Additional priming may be necessary for first start if temperature is below 15°F.

- Grasp starter handle and pull rope out slowly, until it pulls slightly harder. Let rope rewind slowly.
- Pull starter handle rapidly. Do not allow handle to snap back. Allow it to rewind slowly while keeping a firm hold on the starter handle.
- As engine warms up and begins to operate evenly, rotate choke knob slowly to OFF position. If engine falters, return to FULL choke, then slowly move to OFF position.

To Stop Engine

- Run engine for a few minutes before stopping to help dry off any moisture on the engine.
- To help prevent possible freeze-up of starter, proceed as follows.

Electric Starter:

- Connect power cord to switch box on engine, then to 120 volt AC receptacle. With the engine running, push starter button and spin the starter for several seconds. The unusual sound made by spinning the starter will not harm engine or starter. Disconnect the power cord from receptacle first, and then from switch box.

Recoil Starter

- With engine running, pull starter rope with a rapid, continuous full arm stroke three or four times. Pulling the starter rope will produce a loud clattering sound, which is not harmful to the engine or starter.
- To stop engine, move throttle control to “stop” or “off” position.
- Remove ignition key. Do not turn key.
- Disconnect the spark plug wire from the spark plug to prevent accidental starting while equipment is unattended.

NOTE: Do not lose ignition key. Keep it in a safe place. Engine will not start without the ignition key.

- Wipe all snow and moisture from the carburetor cover in the area of the control levers. Also, move control levers back and forth several times.

To Engage Drive

- With the engine running near top speed, move the shift lever into one of the six FORWARD positions or two REVERSE positions. Select a speed

appropriate for the snow conditions that exist. Use the slower speeds until you are familiar with the operation of the snow thrower.

- Squeeze the auger control grip and the augers will turn. Release it and the augers will stop.
- Squeeze traction control grip and the snow thrower will move. Release it and drive motion will stop.
- NEVER move shift lever without releasing drive clutch.

To Engage Augers

- To engage the augers and start throwing snow, squeeze the auger control grip against the left handle. Release to stop the augers.

Auger Control Test

IMPORTANT: Perform the following test before operating your snow thrower for the first time and at the start of each winter season.

Check the adjustment of the auger control as follows:

- When the auger control is released and in the disengaged “up” position, the cable should have very little slack. It should NOT be tight.
- In a well-ventilated area, start the snow thrower engine as instructed earlier in this section under the heading Starting Engine. Make sure the throttle is set in the FAST position.
- While standing in the operator’s position (behind the snow thrower), engage the auger.
- Allow the auger to remain engaged for approximately ten (10) seconds before releasing the auger control. Repeat this several times.
- With the engine running in the FAST position and the auger control lever in the disengaged “up” position, walk to the front of the machine.
- Confirm that the auger has completely stopped rotating and shows NO signs of motion.

IMPORTANT: If the auger shows ANY signs of rotating, immediately return to the operator’s position and shut off the engine. Wait for ALL moving parts to stop before re-adjusting the auger control.

- To readjust the control cable, loosen the hex jam nut on the auger control cable “Z” fitting.
- Rotate the coupling end of the cable counterclockwise to provide more slack.
- Retighten the hex jam nut. See Figure 6.
- Repeat Auger Control Test to verify proper adjustment has been achieved.

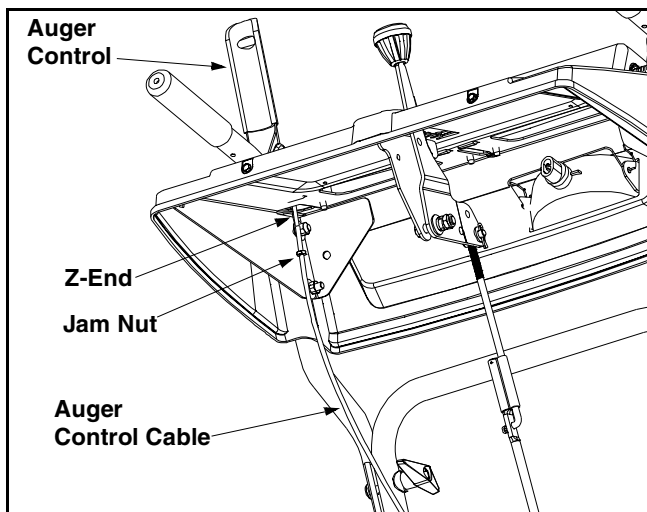

Figure 6

Chute Clean-Out Tool

The chute clean-out tool is conveniently fastened to the rear of the auger housing with a mounting clip. Should snow and ice lodge itself in the discharge chute during operation, proceed as follows to safely clean the chute and chute opening:

- Release both the Auger Control Lever and the Traction/Auger Control Lock Lever.
- Stop the engine by removing the ignition key.
- Remove the clean-out tool from the clip which secures it to the rear of the auger housing.
- Use the shovel-shaped end of the clean-out tool to dislodge and scoop any snow and ice which has formed in and near the discharge chute.



WARNING: Never use your hands to clean snow and ice from the discharge chute or auger housing

- Refasten the clean-out tool to the mounting clip on the rear of the auger housing, reinsert the ignition key and start the snow thrower's engine.
- While standing in the operator's position (behind the snow thrower), engage the auger clutch lever for a few seconds to clear any remaining snow and ice from the discharge chute.

Drift Cutters (If Equipped)

Drift cutters should be used when operating the snow thrower in heavy drift conditions.

On models so equipped, drift cutters are assembled to the auger housing inverted. Remove the carriage bolts by unthreading the hex nuts which secure them, and reinstall the drift cutters in their proper position before operating the snow thrower. See Figure 7.

If your unit is not equipped with drift cutters, contact Customer Support as instructed on page 2 for information regarding price and availability.

Snow Thrower Model

All models

Drift Cutter Kit

OEM-390-679

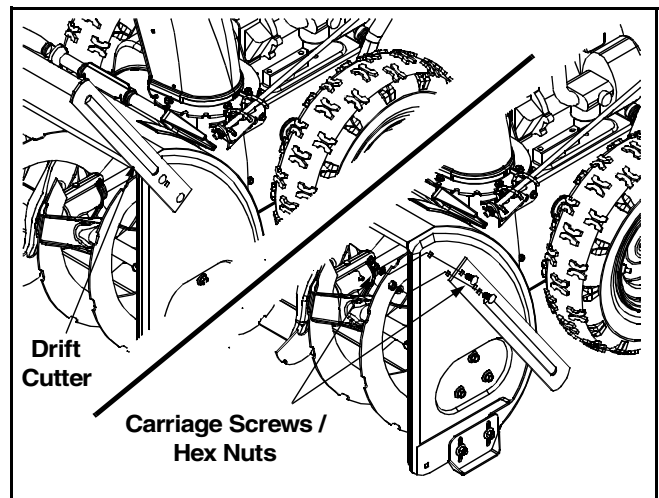

Figure 7

Tire Chains (If Equipped)

Tire chains should be used whenever extra traction is needed. If your unit is not equipped with tire chains, contact Customer Support as instructed on page 2 for information regarding price and availability.

Operating Tips

NOTE: Allow the engine to warm up for a few minutes. The engine will not develop full power until it reaches operating temperature.



WARNING: The temperature of the muffler and the surrounding areas may exceed 150° F. Avoid these areas.

- For the most efficient snow removal, remove snow immediately after it falls.
- Discharge the snow downwind whenever possible.
- Slightly overlap each previous path.
- Set the skid shoes 1/4" below the shave plate for normal usage. The skid shoes may be adjusted upward (to lower the shave plate) for hard-packed snow. Adjust downward (to raise the shave plate) when using on gravel or crushed rock.
- Be certain to follow the precautions found in the To Stop Engine section to prevent possible freeze-up.
- Clean the snow thrower thoroughly after each use.

SECTION 5: MAKING ADJUSTMENTS



WARNING: NEVER attempt to make any adjustments while the engine is running, except where specified in the operator's manual.

Tire Pressure (Pneumatic Tires)

- The tires are overinflated for shipping purposes. Before operating check tire pressure and reduce pressure to between 15psi and 20 psi.

NOTE: If the tire pressure is not equal in both tires, the unit may pull to one side or the other.

Traction Control and Shift Lever

To check the adjustment of the traction control and shift lever, proceed as follows:

- To check the adjustment of the traction control clutch and shift lever, proceed as follows:
- With the engine off, move the shift lever all the way forward to the highest speed. With the traction control lever released, push the snow thrower forward. The unit should roll forward. Then engage the traction control grip. The wheels should stop turning.
- Now release the traction control grip and push the unit again.
- Move the shift lever back to the fast reverse position then all the way forward again. There should be no resistance in the shift lever, and the wheels should keep turning.
- If you have resistance when moving the shift lever or the wheels stop when they should not, loosen the jam nut on the traction control cable and unthread the cable one turn.
- If the wheels do not stop when you engage the traction control clutch grip, loosen the jam nut on the traction control cable and thread the cable in one turn.
- Recheck the adjustment and repeat as necessary. Tighten the jam nut to secure the cable when correct adjustment is reached.



WARNING: Drain the gasoline out of the snow thrower's tank, or place a piece of plastic film under the gas cap to avoid spillage BEFORE making the adjustment.

To test further for correct adjustment, if necessary, proceed as follows:

- Tip the snow thrower forward, allowing it to rest on the auger housing. See Figure 8.

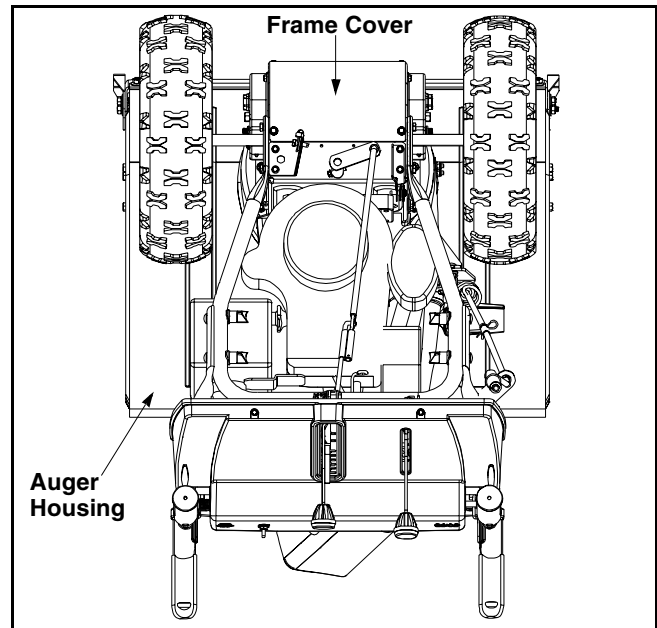

Figure 8

- Remove the frame cover underneath the snow thrower by removing the six self-tapping screws.
- With the traction control released, there must be clearance between the friction wheel and the drive plate in all positions of the shift lever.
- With the traction control engaged, the friction wheel must contact the drive plate. See Figure 9.

If adjustment is necessary:

- Loosen the jam nut on the traction drive cable and adjust the cable as necessary. Refer to Figure 6.
- Retighten the jam nut to secure the cable when correct adjustment is reached.
- Reassemble the frame cover.

NOTE: If you placed plastic film under the gas cap earlier, remove it now.

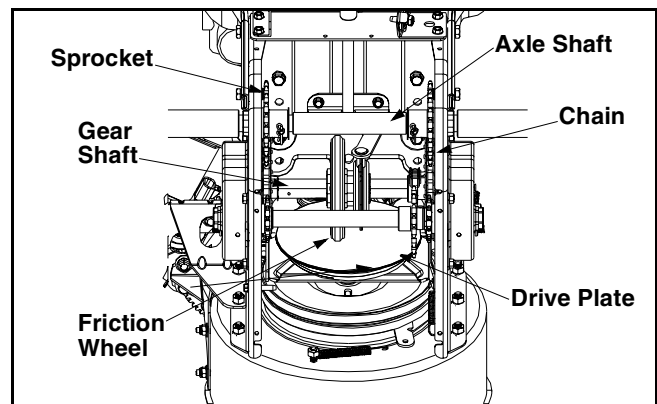

Figure 9

Shift Rod Adjustment

To adjust the shift rod, proceed as follows:

- Remove the hairpin clip and slide the shift rod connector up, to separate the upper shift rod from the lower shift rod. See Figure 10.

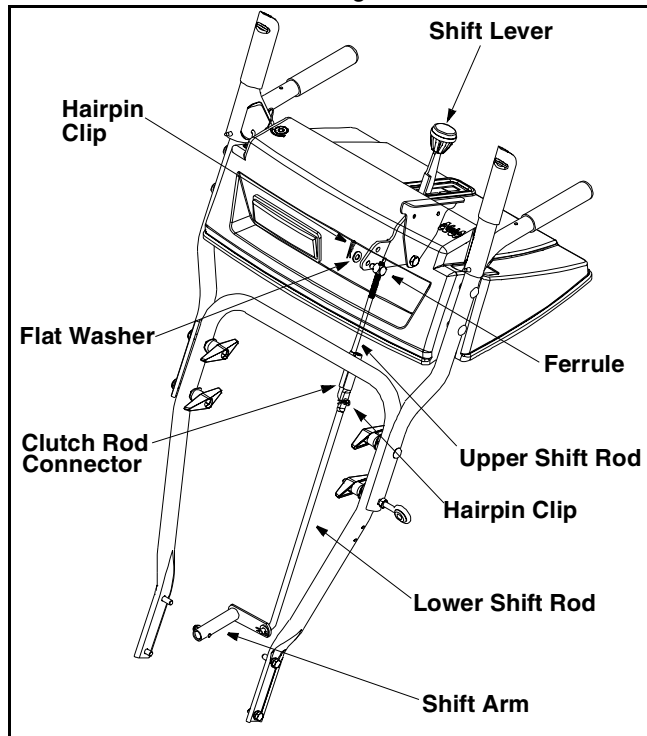

Figure 10

- Place the shift lever into the sixth (6) position.
- Rotate the shift arm clockwise (from the operator's position) as far as it will go.
- Thread the upper shift rod downward until the elbow on its lower end aligns with the hole found in the lower shift rod.
- Reconnect the upper shift rod to the lower shift rod by reinserting the hairpin clip removed earlier and sliding the shift rod connector back down into place.

IMPORTANT: Make certain to check for correct adjustment of the shift rod as instructed under Final Adjustments in the Assembly Section, before operating the snow thrower.

Chute Assembly

The distance snow is thrown can be adjusted by changing the angle of the chute assembly. To do so, stop the engine by removing the ignition key and loosen the plastic wing knobs found on either side of the discharge chute. Pivot the chute upward or downward before re-tightening the wing knobs.

Auger Control

Refer to Auger Control Test in the Operating Section to adjust the auger control.

Skid Shoes

The space between the shave plate and the ground can be adjusted. See Figure 11.

- For close snow removal on a smooth surface, raise skid shoes higher on the auger housing.
- Use a middle or lower position when the area to be cleared is uneven.

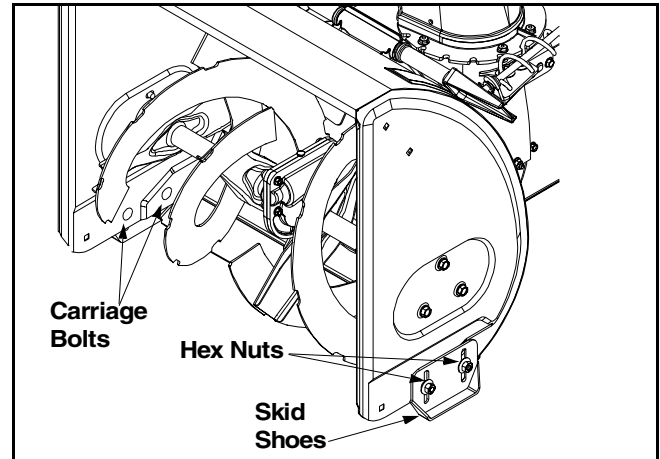

Figure 11



WARNING: Do not operate this snow thrower on gravel as loose gravel can be easily picked up and thrown by the auger causing injury to the operator and/or damage to the snow thrower.

- Adjust skid shoes by loosening the four hex nuts and carriage bolts. Move skid shoes to desired position.
- Make certain the entire bottom surface of skid shoe is against the ground to avoid uneven wear on the skid shoes. Retighten nuts and bolts securely.

Carburetor

- Minor carburetor adjustment may be required to compensate for differences in fuel, temperature, altitude and load.
- Refer to the separate engine manual, packed with your unit, for carburetor adjustment information.



WARNING: If any adjustments need to be made to the engine while the engine is running (e.g. carburetor), keep clear of all moving parts. Be careful of muffler, engine and other surrounding heated surfaces.

Drive Wheels

- The wheels may be adjusted for two different methods of operation. Follow the steps below for adjustment. See Figure 12.

One Wheel Driving

- On the right side of the unit, place click pin in the outside axle hole only. Do not place pin through

wheel hub. This position gives power drive to the left wheel only, making the unit easier to maneuver.

Both Wheels Driving

- Rotate wheel assembly to align hole in the hub with the inner hole on the axle shaft. Insert click pin in the hole. Outer axle shaft hole should be visible.

IMPORTANT: NEVER operate the snow thrower with the click pin inserted through both the RIM and the OUTSIDE HOLE in the axle. Doing so can result in serious damage to the drive system.

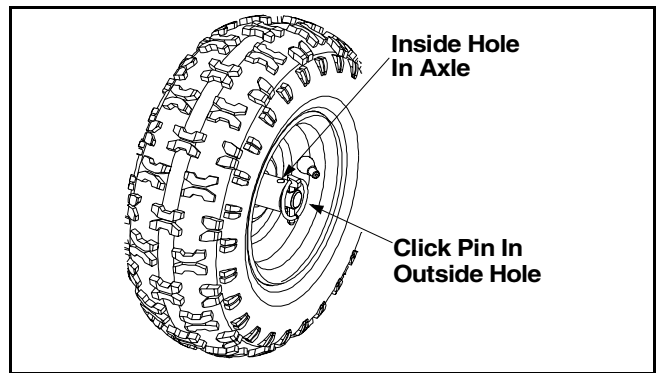

Figure 12

SECTION 6: MAINTAINING YOUR SNOW THROWER



WARNING: Before lubricating, repairing, or inspecting, disengage all clutch levers and stop engine. Wait until all moving parts have come to a complete stop. Disconnect spark plug wire and ground it against the engine to prevent unintended starting.

Lubrication

Engine

Refer to the separate engine manual packed with your unit for all engine lubrication instructions.



WARNING: If any adjustments need to be made to the engine while the engine is running (e.g. carburetor), keep clear of all moving parts. Be careful of muffler, engine and other surrounding heated surfaces.

Wheels

- Oil or spray lubricant into bearings at wheels at least once a season. Pull click pin, remove wheels, clean and coat axles with a multipurpose automotive grease. See Figure 13.

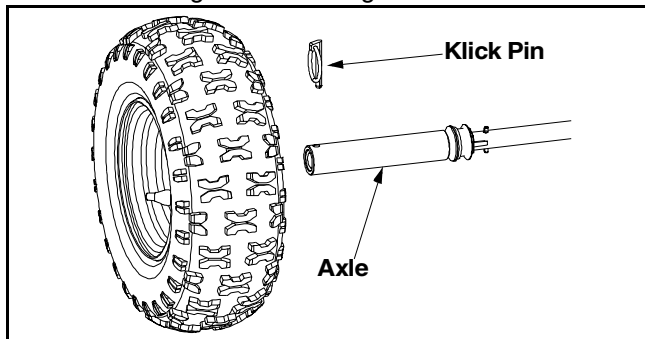

Figure 13

Chute Directional Control

- The worm gear on the chute directional control should be greased with multipurpose automotive grease.

Gear Shaft

Lubricate the gear shaft with 6-n-1 grease at least once a season or after every 25 hours of operation (available at automotive stores, or order part number 737-0170). Refer to Figure 9.

IMPORTANT: Keep all grease and oil off of the rubber friction wheel and aluminum drive plate.

Gear Case

The gear case is lubricated with grease at the factory and it does not require checking. If disassembled for any reason, lubricate with 2 ounces of Shell Alvania grease EPR00, part number 737-0168.

IMPORTANT: Do not overfill the gear case, since damage to the seals could result. Be sure the vent plug is free of grease in order to relieve pressure. See Figure 14.

Auger Shaft

At least once a season, remove the shear bolts on the auger shaft. Spray lubricant inside the shaft and lubricate the plastic auger bearings at least once a season. See Figure 14.

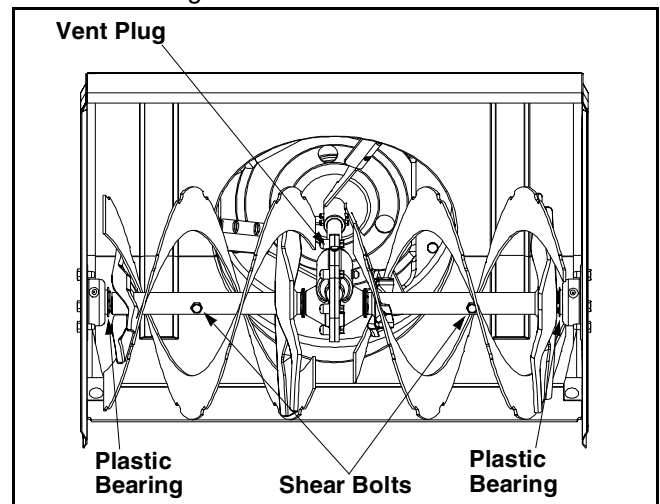

Figure 14

Traction Control / Auger Control Lock

The cams on the ends of the control rods which interlock the traction drive and auger drive controls must be lubricated at least once a season or every 25 hours of operation. The cams can be accessed beneath the handle panel. Use a multi-purpose automotive grease.

Drive and Shifting Mechanism

Lubricate at least once a season or after every 25 hours of operation. Remove the rear cover, lubricate any

chains, sprockets, gears, bearings, shafts, and shifting mechanism at least once a season. Use engine oil or a spray lubricant. **Avoid getting oil on the friction wheel rubber and aluminum drive plate.** Refer to Figure 9.

There is a grease fitting on the top of the axle shaft which drives the rear track drive wheels on both sides of the unit. Grease these fittings every 25 hours or once a season.

SECTION 7: SERVICING YOUR SNOW THROWER



WARNING: Before servicing, repairing, or inspecting, disengage all clutch levers and stop engine. Wait until all moving parts have come to a complete stop. Disconnect spark plug wire and ground it against the engine to prevent unintended starting.

Engine

Refer to the separate engine manual packed with your unit for all engine maintenance procedures.

Augers

- The augers are secured to the spiral shaft with two shear bolts and hex lock nuts. If you hit a hard foreign object or ice jam, the snow thrower is designed so that the bolts may shear. Refer to Figure 14.
- If the augers will not turn, check to see if the bolts have sheared. Replacement shear bolts and hex lock nuts have been provided with the snow thrower. When replacing bolts, spray an oil lubricant into shaft before inserting new bolts.

IMPORTANT: NEVER replace the auger shear bolts with standard hex bolts. Any damage to the auger gearbox or other components as a result of doing so will NOT be covered by your snow thrower's warranty.

Shave Plate and Skid Shoes

- The shave plate and skid shoes on the bottom of the snow thrower are subject to wear. They should be checked periodically and replaced when necessary.
- To remove skid shoes, remove the four carriage bolts, cupped washers and hex nuts which attach them to the snow thrower. Reassemble new skid shoes with the four carriage bolts, cupped washers (cupped side goes against skid shoes) and hex nuts. See Figure 15.

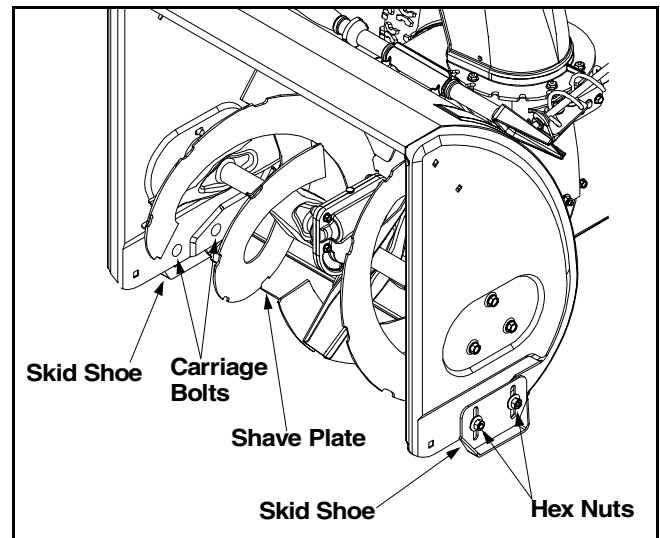

Figure 15

Belt Removal And Replacement

Auger Belts

NOTE: It is necessary to remove both belts in order to change either one. If changing just one belt, be certain to check the condition of the other belt.

- Remove the plastic belt cover at the front of the engine by removing the two self-tapping screws. See Figure 16.

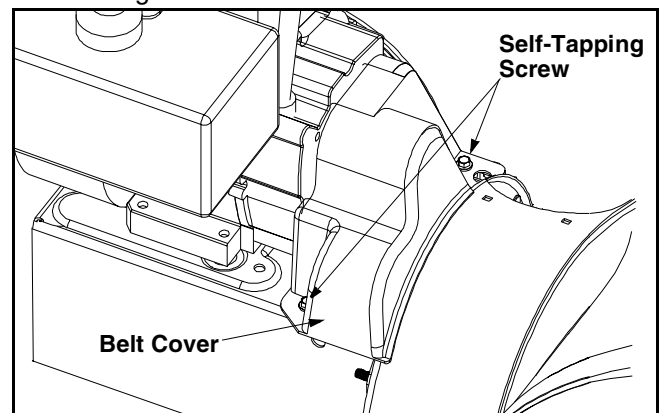

Figure 16

- Drain the gasoline from the snow thrower, or place a piece of plastic film under the gas cap.
- Tip the snow thrower up and forward so that it rests on its auger housing.
- Remove the six self-tapping screws from the frame cover underneath the snow thrower.
- Roll the front and rear auger belts off the auger drive pulley. See Figure 17.
- Unhook the idler spring from the hex bolt on the auger housing. See Figure 18.
- Back out the stop bolt until the support bracket rests on the auger pulley.

NOTE: Loosening the six nuts that connect the frame to the auger housing may aid in belt removal.

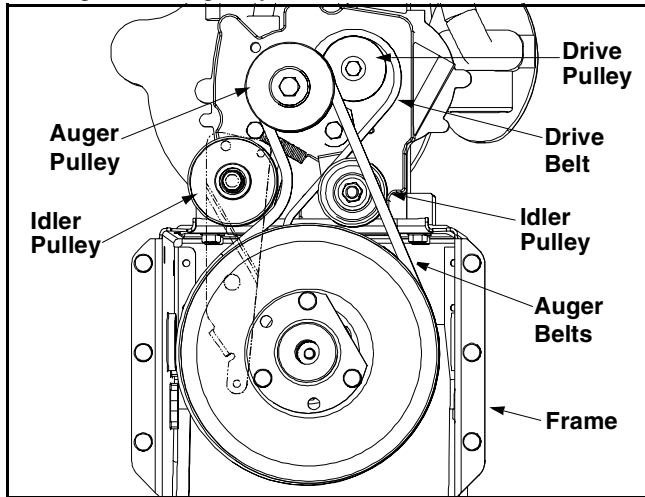

Figure 17

- Lift the rear auger belt from the auger pulley, and slip the belt between the support bracket and the auger pulley. Repeat this step for the front auger belt.
- Replace both auger drive belts by following instructions in reverse order.

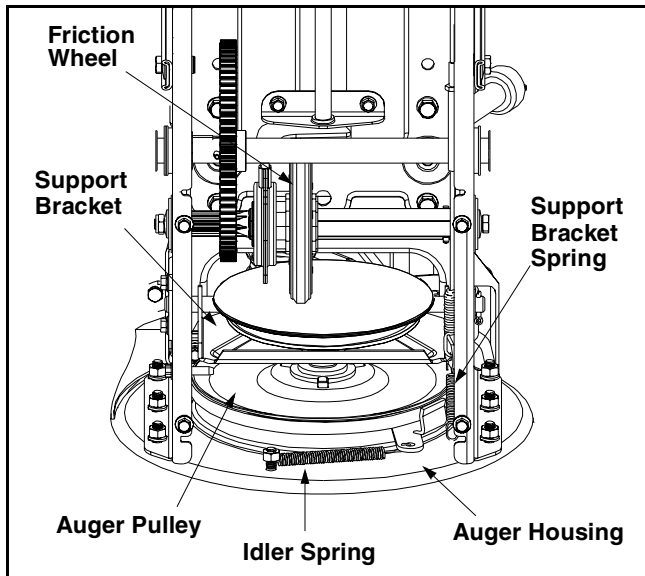

Figure 18

NOTE: If you placed plastic film under the gas cap, be certain to remove it before operating the snow thrower

Drive Belt

- Follow the first four steps of the instructions for servicing the auger belts.
- Pull the idler pulley up and lift the belt off the wheel drive pulley and friction wheel disc. See Figure 17.
- Back out the stop bolt until the support bracket rests on the auger pulley. See Figure 19.

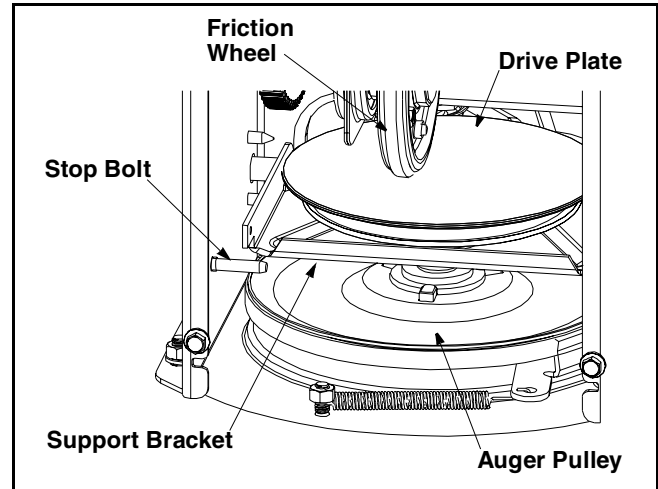

Figure 19

- Slip the belt between the friction wheel and drive disc. Remove and replace the belt. Reassemble following the instructions in reverse order.

NOTE: The support bracket must rest on the stop bolt after the new belt has been assembled.

Replacing Friction Wheel Rubber

The rubber on the friction wheel is subject to wear and should be checked after 25 hours of operation, and periodically thereafter. Replace the friction wheel rubber if any signs of wear or cracking are found.

- Drain the gasoline from the snow thrower, or place a piece of plastic under the gas cap.
- Tip the snow thrower up and forward, so that it rests on the housing.
- Remove the six self-tapping screws from the frame cover underneath the snow thrower.
- Remove the click pin that secures the left wheel to the axle and slide the wheel from the axle.
- Using a 7/8" wrench to hold the shaft, loosen, but do not completely remove, the hex nut and bell washer on the left end of gear shaft. See Figure 20.
- Lightly tap the hex nut to dislodge the ball bearing from the right side of frame before removing the hex nut and bell washer from left end of shaft.
- Move the gear shaft to the right and slide the friction wheel assembly from the shaft.

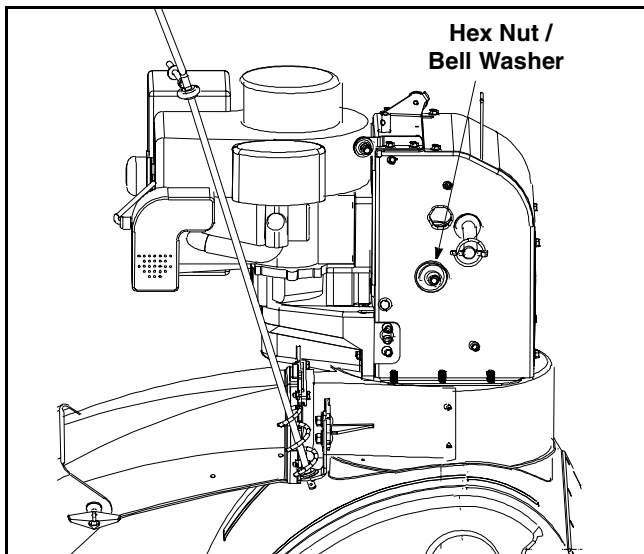

Figure 20

- Remove the four screws from the friction wheel assembly. Remove the friction wheel rubber from between the friction wheel plates. See Figure 21.
- Reassemble the new friction wheel rubber to the friction wheel plates and hub, tightening the six screws in rotation and with equal force.
- Position the friction wheel assembly up onto the pin of the shift rod assembly, and slide the hex shaft through the friction wheel assembly. Reassemble in reverse order.

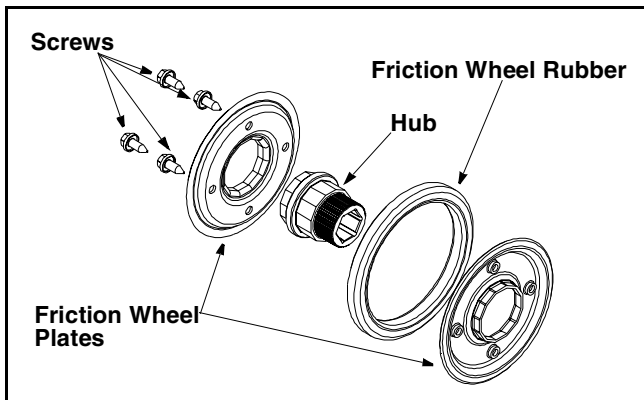

Figure 21

Off-Season Storage



WARNING: Never store the machine or fuel container indoors where there is an open flame, spark, or pilot light such as on water heater, furnace, clothes dryer, or other gas appliance.



WARNING: Drain fuel into an approved container outdoors, away from an open flame. Allow engine to cool. Extinguish cigarettes, cigars, pipes, and other sources of ignition prior to draining fuel. Fuel left in engine for extended periods deteriorates and will cause starting problems.

If unit is to be stored over 30 days, prepare for storage as follows:

- Remove gasoline from carburetor and fuel tank to prevent gum deposits from forming on these parts and causing possible malfunction of engine.
- Run engine until fuel tank is empty and engine stops due to lack of fuel.
- Drain carburetor by pressing upward on bowl drain, located below the carburetor cover.

NOTE: Fuel stabilizer is an acceptable alternative in minimizing the formation of fuel gum deposits during storage. Do not drain carburetor if using fuel stabilizer.

- Wipe equipment with an oiled rag to prevent rust.
- Remove spark plug and pour one ounce of engine oil through spark plug hole into cylinder. Cover spark plug hole with rag. Crank engine several times to distribute oil. Replace spark plug.
- Follow the lubrication recommendations found in the Maintenance Section.
- Always store the snow thrower in a clean, dry area.

NOTE: When storing any type of power equipment in an unventilated or metal storage shed, care should be taken to rust proof the equipment. Using a light oil or silicone, coat the equipment, especially any chains, springs, bearings and cables.

SECTION 8: TROUBLE SHOOTING

Trouble	Possible Cause(s)	Corrective Action
Engine fails to start	Fuel tank empty, or stale fuel. Blocked fuel line. Choke not in ON position Faulty spark plug. Key not in switch on engine. Spark plug wire disconnected. Primer button not depressed. Fuel shut-off valve closed (if so equipped).	Fill tank with clean, fresh gasoline. Fuel will not last over thirty days unless a fuel stabilizer is used. Clean fuel line. Move switch to ON position Clean, adjust gap or replace. Insert key. Connect spark plug wire. Refer to the engine manual. Open fuel shut-off valve.
Engine runs erratic	Unit running on CHOKE. Blocked fuel line or stale fuel. Water or dirt in fuel system. Carburetor out of adjustment.	Move choke lever to OFF position. Clean fuel line; fill tank with clean fresh gasoline. Fuel will not last over thirty days unless a fuel stabilizer is used. Drain fuel tank. Refill with fresh fuel. Refer to the engine manual.
Loss of power	Spark plug wire loose. Gas cap vent hole plugged. Exhaust port plugged.	Connect and tighten spark plug wire. Remove ice and snow from cap. Be certain vent hole is clear. Clean following the engine manual.
Engine overheats	Carburetor not adjusted properly. Incorrect fuel mixture.	Refer to the engine manual packed with your unit or have carburetor adjusted by an authorized service dealer. Drain fuel tank. Refill with proper fuel mixture.
Excessive vibration	Loose parts or damaged auger.	Stop engine immediately and disconnect spark plug wire. Tighten all bolts and nuts. Make all necessary repairs. If vibration continues, have unit serviced by an authorized service dealer.
Unit fails to propel itself	Incorrect adjustment of drive cable. Drive belt loose or damaged.	Adjust drive cable. Replace drive belt.
Unit fails to discharge snow	Discharge chute clogged. Foreign object lodged in auger. Incorrect adjustment of drive cable. Drive belt loose or damaged.	Stop engine immediately and disconnect spark plug wire. Clean discharge chute and inside of auger housing. Stop engine immediately and disconnect spark plug wire. Remove object from auger. Adjust drive cable. Replace drive belt.

NOTE: For repairs beyond the minor adjustments above, contact your local authorized service dealer.

Models 643 & 663

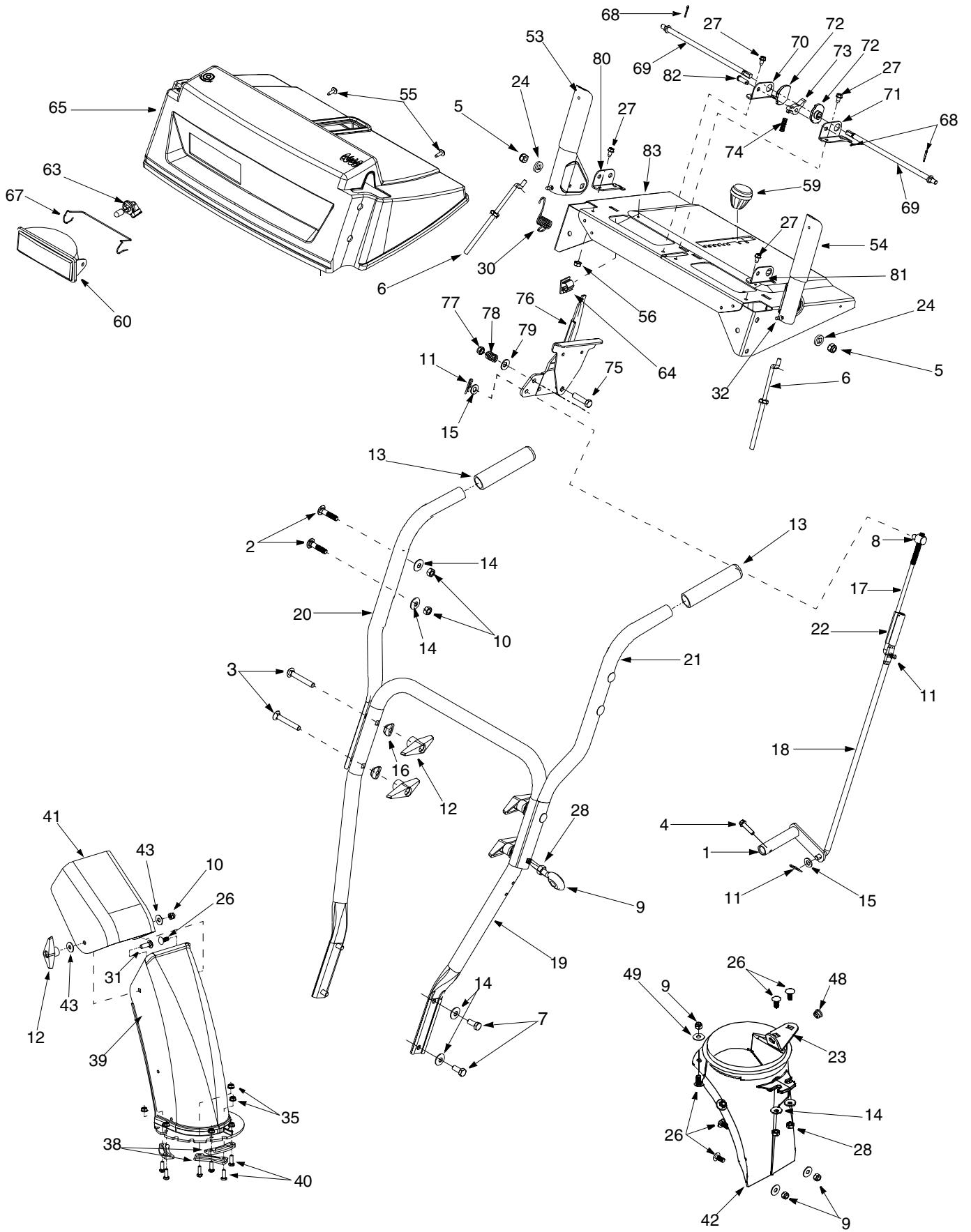

Models 643 & 663

Ref. No.	Part No.	Part Description	Ref. No.	Part No.	Part Description
1.	684-0008A	Shift Arm Assembly	39.	731-1300B	Lower Chute
2.	710-0458	Carriage Bolt 5/16-18 x 1.75"	40.	710-3015	Hex Cap Screw 1/4-20 x .75
3.	710-0449	Carriage Bolt 5/16-18 x 2.25"	41.	731-0921	Upper Chute
4.	710-0788	TT Screw 1/4-20 x 1"	43.	736-0159	5/16 Washer
5.	712-0429	Hex Lock Nut 5/16-18	47.	746-0901	Control Cable
6.	746-0778	Z Fitting Cable	48.	741-0475	Plastic Bushing
7.	710-1880	Hex Screw 5/16-18 x .75"	49.	736-0159	5/16 Washer
8.	711-0677	Ferrule	53.	684-0036A	Handle Assembly RH
9.	747-0697	Eyebolt	54.	684-0037B	Handle Assembly LH
	735-0234	Grommet Only	55.	710-1003	Special Hex Screw
10.	712-3068	Hex Nut 5/16-18	56.	712-0271	Hex Sems Nut: 1/4-20
11.	714-0104	Cotter Pin	57.	712-0693	Hex Nut
12.	720-0284	Handle Knob	59.	720-0232	Shift Knob
13.	720-0274	Grip	60.	725-1672	Lamp Housing
14.	736-0242	Belleville Washer	63.	725-1658	Halogen Lamp: 50W, 12V
15.	736-0275	Flat Washer	64.	726-0152	Mounting Clamp
16.	736-0451	Saddle Washer	65.	731-04144	Handle Panel
17.	747-0620A	Shift Rod: Upper	67.	747-1136	Headlight Retainer
18.	747-0621	Shift Rod: Lower	68.	714-0507	Cotter Pin: 3/32 x .75
19.	749-0951	Lower Handle	69.	747-0877	Cam Rod
20.	749-0952A	Upper Handle: L Style RH	70.	784-5680	RH Handle Support Bracket
21.	749-0953A	Upper Handle: L Style LH	71.	784-5679	LH Handle Support Bracket
22.	750-0963	Connector: Shift Rod	72.	748-0362	Cam Handle Lock
23.	784-5647	Chute Crank Bracket	73.	748-0363	Handle Lock Pawl
24.	736-0509	Washer .72 OD x .135 ID	74.	732-0145	Compression Spring: .36 x 1.0
25.	710-0262	Carriage Bolt: 5/16-18 x 1.5"	75.	710-0459A	Hex Cap Screw: 3/8-24 x 1.5
26.	710-0451	Carriage Bolt: 5.16-18 x .750"	76.	784-5619A	Shift Handle
27.	710-0599	TT Screw: 1/4-20 x 0.5"	77.	712-0116	Jam Nut, 3/8-24
28.	712-3010	Hex Nut 5/16-18	78.	732-0193	Comp. Spring: .39 x .6 x .88
30.	732-0746	Torsion Spring	79.	736-0105	Bell Washer
31.	710-0276	Carriage Screws 5/16-18 x 1.0	80.	784-5682	RH Handle Support Bracket
32.	735-0199A	Rubber Bumper	81.	784-5681	LH Handle Support Bracket
35.	712-3027	Hex Flange Lock Nut	82.	711-0653	Clevis Pin
38.	731-0851A	Chute Flange Keeper	83.	684-0103	Handle Panel

Models 643 & 663

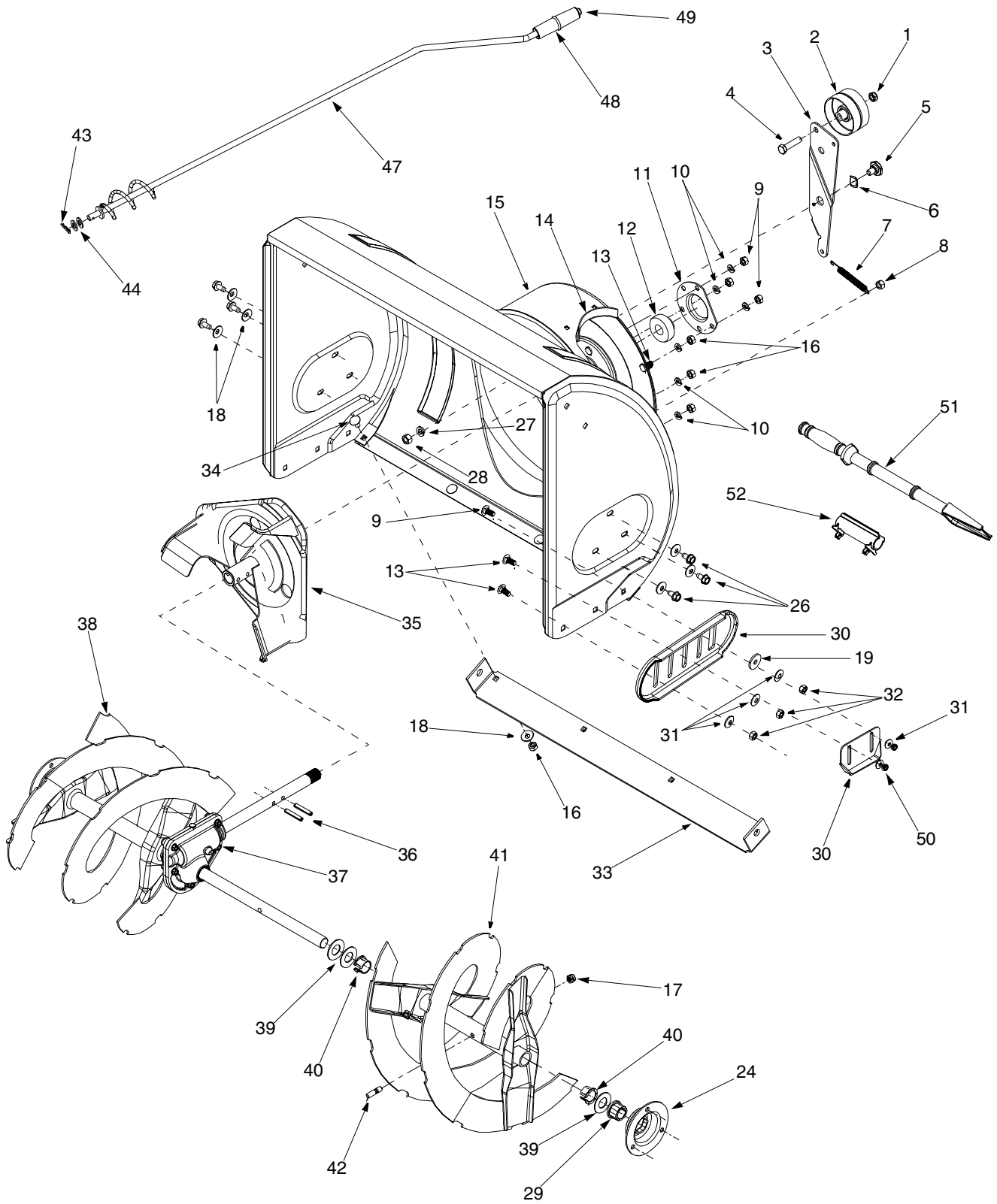

Models 643 & 663

Ref. No.	Part No.	Part Description	Ref. No.	Part No.	Part Description
1.	712-0116	Lock Jam Nut 3/8-24		784-5038B	Skid Shoe (If Equipped)
2.	756-0178	Flat Idler	31.	736-0242	Bell Washer
3.	784-5632B	Auger Idler Arm	32.	712-3010	Hex Nut 5/16-18
4.	710-0459A	Hex Cap Screw 3/8-24 x 1.50	33.	784-5582A	Shave Plate
5.	738-0281	Shoulder Screw	34.	710-0260	Carriage Bolt 5/16-18 x .62
6.	736-0167	Wave Washer	35.	684-0065	Impeller Assembly
7.	732-0611	Extension Spring	36.	715-0114	Pin
8.	712-3068	Hex Nut 5/16-18	37.	618-0122A	28" Gear Ass'y
9.	710-0276	Carriage Bolt, 5/16-18 x 1.00	38.	605-5196A	28" Spiral RH
10.	736-0119	Lock Washer 5/16	39.	736-0188	Flat Washer
11.	05931A	Bearing Housing	40.	741-0493A	Flange Bushing
12.	741-0309	Ball Bearing	41.	605-5197A	28" Spiral LH
13.	710-0451	Carriage Bolt, 5/16-18 x .75	42.	710-0890A	Shear Bolt 5/16-18 x 1.5
14.	705-5226	Chute Reinforcement	43.	714-0104	Hairpin Clip
15.	684-0041D	28" Housing Ass'y	44.	736-0185	Flat Washer
16.	712-3010	Hex Nut 5/16-18	47.	705-5204A	Chute Crank
17.	712-0429	Lock Nut 5/16-18	48.	720-0201A	Chute Crank Knob
18.	736-0242	Belleville Washer	49.	726-0100	Push Cap
19.	736-0231	Flat Wshr, .344ID x 1.125 OD	50.	712-3068	Hex Nut 5/16-18
24.	784-5618	Bearing Housing	51.	731-2643	Clean-Out Tool
26.	710-0604A	Hex Screw 5/16-18	52.	731-2635	Clean-Out Tool Mount
27.	736-0169	Lock Washer 3/8		777I20711	Label: Handle Panel (L)
28.	712-0798	Hex Nut 3/8-16		777I20722	Label: Handle Panel (R)
29.	741-0245	Hex Flange Bearing		777S30514	Label: Housing Danger
30.	784-5580	Slide Shoe		777S30511	Label: Chute Danger

Models 643 & 663

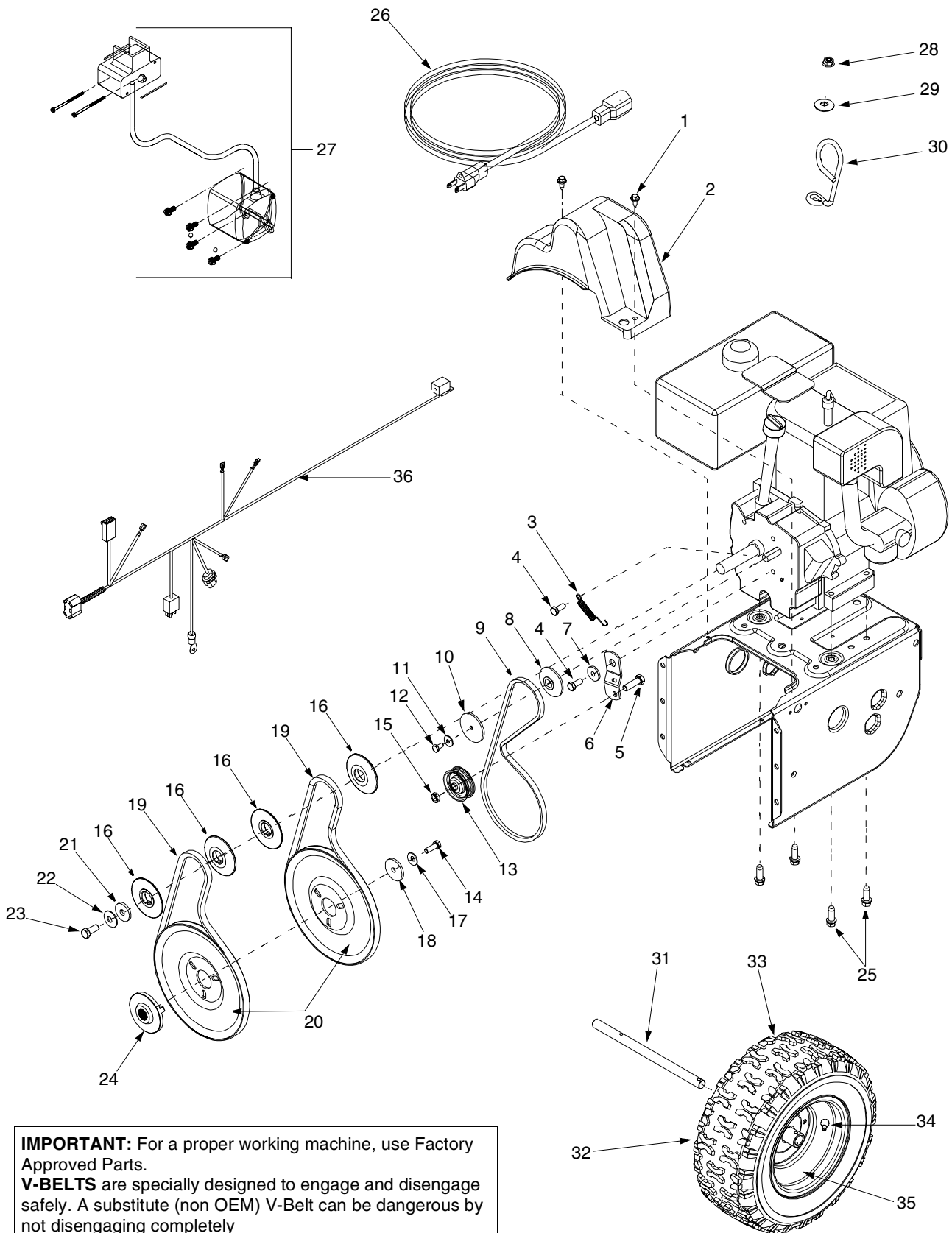

IMPORTANT: For a proper working machine, use Factory Approved Parts.
V-BELTS are specially designed to engage and disengage safely. A substitute (non OEM) V-Belt can be dangerous by not disengaging completely

Models 643 & 663

Ref. No.	Part No.	Part Description
1.	710-1652	Hex Washer Screw 1/4-20 x .625
2.	731-1324	Belt Cover
3.	732-0710	Extension Spring
4.	710-0627	Hex Screw 5/16-24 x .75
5.	710-3005	Hex Cap Screw 3/8-16 x 1.25
6.	05896A	Drive Clutch Idler Bracket
7.	748-0234	Shoulder Spacer
8.	756-0987	Pulley Half
9.	754-0346	V-Belt
10.	756-0986	Pulley Half
11.	736-0270	Bell Washer
12.	710-0230	Hex Cap Screw 1/4-28 x .50
13.	756-0313	Flat Idler
14.	710-1245B	Lock Hex Cap Screw 5/16-24
15.	712-0181	Lock Jam Nut 3/8-16
16.	756-0569	Pulley Half
17.	736-0242	Bell Washer
18.	736-0505	Flat Washer
19.	754-0430B	Belt
20.	756-0967	Auger Pulley
21.	736-0247	Flat Washer 3/8 x 1.25 OD
22.	736-0331	Bell Washer
23.	710-0696	Hex Cap Screw 3/8-24
24.	748-0360	Adapter Pulley
25.	710-0654A	Hex Screw 3/8-16 x 1.0
26.	629-0071	Extension Cord
27.	OEM-390-987	Electric Start Kit
28.	712-0324	Lock Nut, 1/4-20
29.	736-0173	Flat Washer, .28 x .74 x .063
30.	732-0705	Cable Guide
31.	738-0830	Axle 16"
32.	734-1712A	Wheel Ass'y Comp 16.5" x 4.8"
33.	734-1525	Tire 16.0" x 6.50" x 8.0"
34.	734-0255	Tubeless Air Valve
35.	734-1711A	Rim Assembly
36.	629-0059	Upper Harness Assembly

Models 643 & 663

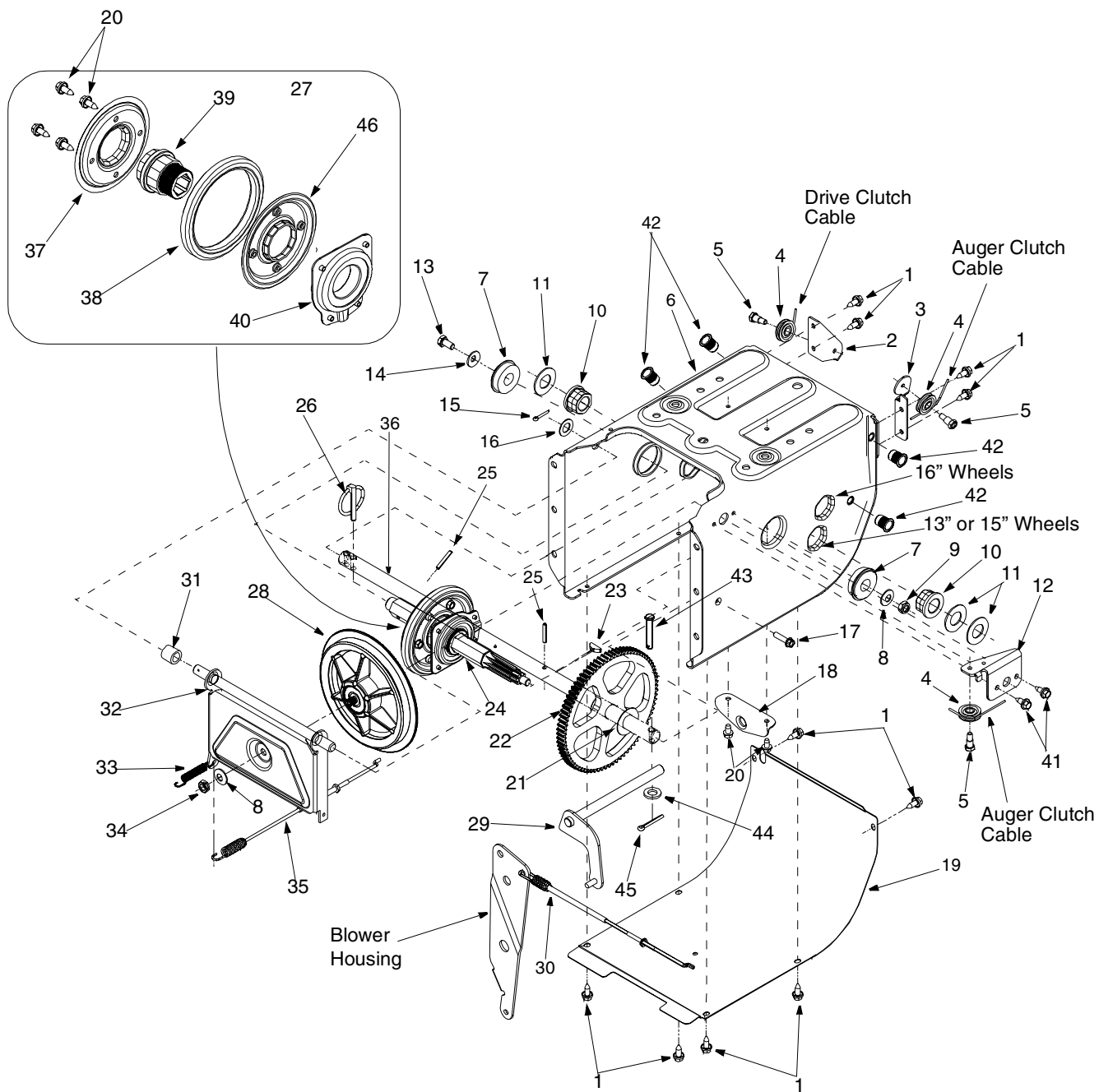

Models 643 & 663

Ref. No.	Part No.	Part Description	Ref. No.	Part No.	Part Description
1.	710-0599	Hex Screw	25.	715-0249	Roll Pin
2.	784-5688	Drive Cable Guide Bracket	26.	714-0143	Klik Pin
3.	784-5687A	Auger Clutch Cable Bracket	27.	684-0042C	Friction Wheel Assembly
4.	756-0625	Roller Cable	28.	656-0012A	Friction Disc Wheel
5.	738-0924	Hex Screw 1/4-28	29.	684-0013B	Wheel Shift Rod Assembly
6.	784-5630B	Frame Assembly	30.	746-0897	Drive Cable
7.	741-0563	Ball Bearing	31.	748-0190	Spacer
8.	736-0105	Bell Washer	32.	684-0021	Friction Wheel Bracket Assembly
9.	712-0116	Lock Jam Nut	33.	732-0264	Extension Spring
10.	741-0598	Hex Flange Bearing	34.	712-0711	Jam Nut 3/8-24
11.	736-0188	Flat Washer	35.	746-0898B	Drive Cable
12.	784-5689A	Front Support Guide Bracket	36.	738-0869	Axle 13" Wheels
13.	710-0538	Lock Hex Screw		738-0830	Axle 16" Wheels
14.	736-0242	Bell Washer .340 ID x .872 OD	37.	790-00010	Friction Plate
15.	714-0474	Cotter Pin	38.	735-0243B	Friction Wheel Rubber
16.	736-0160	Flat Washer .536 ID x .930 OD	39.	718-0301A	Friction Wheel Hub
17.	710-0809	Hex Washer Screw 1/4-20	40.	618-0063A	Friction Wheel Bearing
18.	784-5590	Frame Shift Bracket	41.	710-1652	Tap Screw 1/4-20
19.	784-5638	Frame Cover	42.	712-0703A	Insert Nut 5/16-18
20.	710-0599	Hex Washer Screw 1/4-20	43.	711-1364	Clevis Pin
21.	736-0351	Flat Washer .760 ID x .50 OD	44.	736-0142	Flat Washer .281 ID x .50 OD
22.	717-1445	Gear	45.	714-0507	Cotter Pin
23.	714-0126	Key	46.	790-00011	Friction Plate
24.	717-1444	7-Tooth Shaft			

Notes

MANUFACTURER'S LIMITED WARRANTY FOR:



The limited warranty set forth below is given by MTD LLC with respect to new merchandise purchased and used in the United States, its possessions and territories.

MTD LLC warrants this product against defects for a period of two (2) years commencing on the date of original purchase and will, at its option, repair or replace, free of charge, any part found to be defective in materials or workmanship. This limited warranty shall only apply if this product has been operated and maintained in accordance with the Operator's Manual furnished with the product, and has not been subject to misuse, abuse, commercial use, neglect, accident, improper maintenance, alteration, vandalism, theft, fire, water, or damage because of other peril or natural disaster. Damage resulting from the installation or use of any accessory or attachment not approved by MTD LLC for use with the product(s) covered by this manual will void your warranty as to any resulting damage.

Normal wear parts or components thereof are subject to separate terms as follows: All normal wear parts or component failures will be covered on the product for a period of 90 days regardless of cause. After 90 days, but within the two year period, normal wear part failures will be covered ONLY IF caused by defects in materials or workmanship of OTHER component parts. Normal wear parts and components include, but are not limited to: batteries, belts, blades, blade adapters, grass bags, rider deck wheels, seats, snow thrower skid shoes, shave plates, auger spiral rubber, tires.

HOW TO OBTAIN SERVICE: Warranty service is available, WITH PROOF OF PURCHASE, through your local authorized service dealer. To locate the dealer in your area, check your Yellow Pages, or contact MTD LLC at P.O. Box 361131, Cleveland, Ohio 44136-0019, 1-800-800-7310, 1-330-220-4683 or log on to our Web site at www.mtdproducts.com.

This limited warranty does not provide coverage in the following cases:

- a. The engine or component parts thereof. These items carry a separate manufacturer's warranty. Refer to the applicable manufacturer's warranty for terms and conditions.
- b. Log splitter pumps, valves, and cylinders have a separate one year warranty.
- c. Routine maintenance items such as lubricants, filters, blade sharpening, tune-ups, brake adjustments, clutch adjustments, deck adjustments, and normal deterioration of the exterior finish due to use or exposure.
- d. MTD LLC does not extend any warranty for products sold or exported outside of the United States, its possessions and territories, except those sold through MTD LLC's authorized channels of export distribution.
- e. Parts that are not genuine MTD parts are not covered by this warranty.
- f. Service completed by someone other than an authorized service dealer is not covered by this warranty.
- g. Transportation charges and service calls are not covered.

No implied warranty, including any implied warranty of merchantability of fitness for a particular purpose, applies after the applicable period of express written warranty above as to the parts as identified. No other express warranty, whether written or oral, except as mentioned above, given by any person or entity, including a dealer or retailer, with respect to any product, shall bind MTD LLC. During the period of the warranty, the exclusive remedy is repair or replacement of the product as set forth above.

The provisions as set forth in this warranty provide the sole and exclusive remedy arising from the sale. MTD LLC shall not be liable for incidental or consequential loss or damage including, without limitation, expenses incurred for substitute or replacement lawn care services or for rental expenses to temporarily replace a warranted product.

Some states do not allow the exclusion or limitation of incidental or consequential damages, or limitations on how long an implied warranty lasts, so the above exclusions or limitations may not apply to you.

In no event shall recovery of any kind be greater than the amount of the purchase price of the product sold. **Alteration of safety features of the product shall void this warranty.** You assume the risk and liability for loss, damage, or injury to you and your property and/or to others and their property arising out of the misuse or inability to use the product.

This limited warranty shall not extend to anyone other than the original purchaser or to the person for whom it was purchased as a gift.

HOW STATE LAW RELATES TO THIS WARRANTY: This limited warranty gives you specific legal rights, and you may also have other rights which vary from state to state.

MTD LLC, P.O. BOX 361131 CLEVELAND, OHIO 44136-0019 1-800-800-7310