

OPERATOR'S MANUAL

White
OUTDOOR 

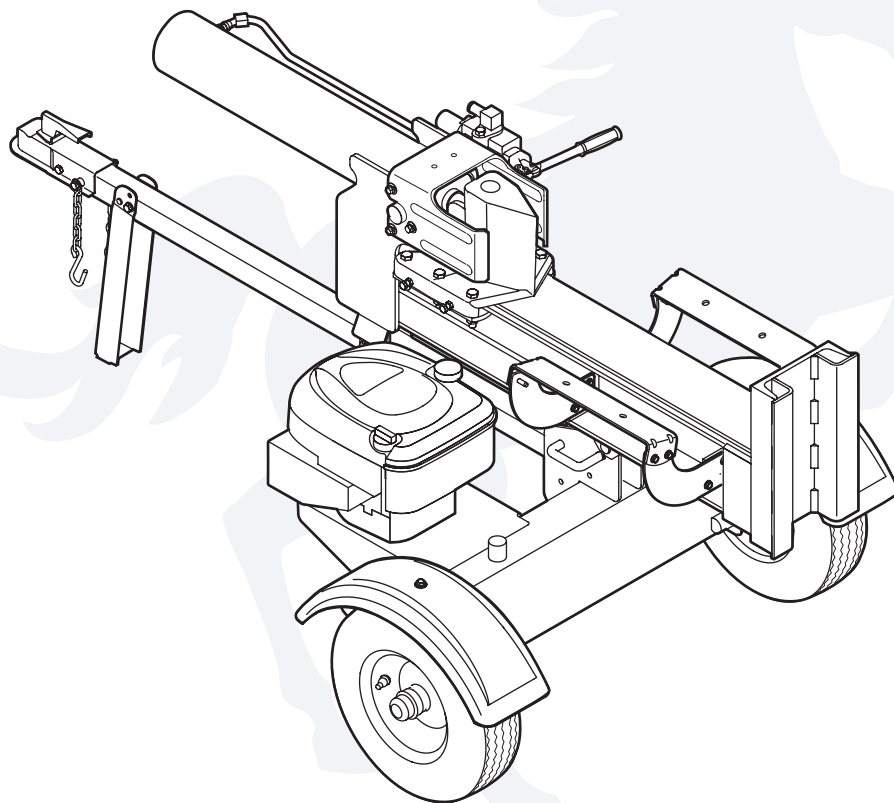

Log Splitter — Model 510

IMPORTANT

READ SAFETY RULES AND INSTRUCTIONS CAREFULLY BEFORE OPERATION

Warning: This unit is equipped with an internal combustion engine and should not be used on or near any unimproved forest-covered, brush-covered or grass-covered land unless the engine's exhaust system is equipped with a spark arrester meeting applicable local or state laws (if any). If a spark arrester is used, it should be maintained in effective working order by the operator. In the State of California the above is required by law (Section 4442 of the California Public Resources Code). Other states may have similar laws. Federal laws apply on federal lands. A spark arrester for the muffler is available through your nearest engine authorized service dealer or contact the service department, P.O. Box 361131 Cleveland, Ohio 44136-0019.

This Operator's Manual is an important part of your new log splitter. It will help you assemble, prepare and maintain the unit for best performance. Please read and understand what it says.

Table of Contents

Safety Labels	Page 3	Maintaining Your Log Splitter	Page 12
Safe Operation Practices	Page 4	Troubleshooting.....	Page 16
Setting Up Your Log Splitter	Page 6	Illustrated Parts List	Page 18
Operating Your Log Splitter	Page 8	Warranty	Back Cover

Finding and Recording Model Number



BEFORE YOU START ASSEMBLING
YOUR NEW EQUIPMENT

Please locate the model plate on the equipment and copy the information to the sample model plate provided to the right. You can locate the model plate by standing behind the unit and looking down at the hydraulic tank. This information will be necessary to use the web site or obtain assistance from your *White Outdoor* dealer.



White
OUTDOOR
www.whiteoutdoor.com

MTD LLC
P. O. BOX 361131
CLEVELAND, OH 44136
DEALER LOCATOR PHONE NUMBER: 800-949-4483

Please do **NOT** return the unit to the retailer from which it was purchased, without first contacting Customer Support.

Customer Support

If you have difficulty assembling this product or have any questions regarding the controls, operation, or maintenance of this unit, you can seek help from the experts. To reach a local *White Outdoor* dealer or retailer, visit www.whiteoutdoor.com or or phone our Customer Support line at (800)-949-4483.

Engine Information

The engine manufacturer is responsible for all engine-related issues with regard to performance, power-rating, specifications, warranty and service. Please refer to the engine manufacturer's Owner's/Operator's Manual packed separately with your unit for more information.

Safety Labels Found On Your Log Splitter

<p>⚠ WARNING PERSON STABILIZING LOG ON SPLITTER MUST BE SAME PERSON WHO OPERATES CONTROL VALVE. KEEP HANDS AWAY FROM WEDGE AND MOVING PARTS.</p>	<p>CONTROL VALVE</p> <p>• REVERSE ↑</p> <p>• NEUTRAL</p> <p>• FORWARD ↓</p>
<p>DANGER KEEP HANDS and FEET AWAY</p> 	<p>LOG DISLODGER Retract wedge, lodged wood will be automatically removed.</p>

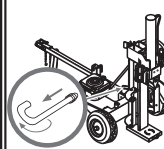
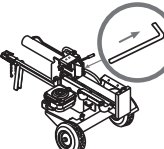
<p>VERTICAL Vertical Position Lock</p> 	<p>HORIZONTAL Horizontal Position Lock</p> 	<p>OPERATOR'S INSTRUCTIONS</p> <ol style="list-style-type: none"> 1. Place log splitter on flat dry solid ground. 2. Lock in either the horizontal or vertical position. 3. Set the engine throttle at maximum speed. 4. Place the log against the end plate. 5. Stabilize the log when needed on its sides, never on the end between the log and splitting wedge. 6. Only one adult should stabilize the log and operate the control. 7. Move the control handle in the splitting direction. 8. Release the control handle to stop the wedge movement. <p style="text-align: right; font-size: small;">S32605 AC</p>	<p>⚠ DANGER</p> <ol style="list-style-type: none"> 1. Read operator's manual. 2. Keep hands away from wedge, end plate, partly split wood and moving parts. 3. Hold log on its sides not on ends. 4. Only one operator permitted. Adult who loads and holds log must be the one who operates control handle. Keep bystanders, helpers and children at least 10 feet away. 5. Never check for leaks with your hands. High pressure fluid can escape through a pin hole leak and cause serious injury by puncturing the skin and causing blood poisoning. 6. Operate the log splitter on level surface. 7. Lock it in vertical or horizontal position. 8. Wear protective work gloves, safety shoes and safety glasses, watch your footing. 9. Never operate under the influence of alcohol or drugs. 10. Do not refuel a hot or running engine.
--	---	--	---

⚠ WARNING - TO AVOID INJURY AND/OR PROPERTY DAMAGE

<p>MOVING LOG SPLITTER BY HAND</p> <ul style="list-style-type: none"> • Lock beam in horizontal position. • Lock jack stand in down position. • Do not attempt to move log splitter up or down a slope by hand 	<ul style="list-style-type: none"> • If coupler adjustment is needed, refer to owner's manual. • Raise jack stand and latch securely in full up position. • Attach safety chains to tow vehicle. • Do not tow faster than 45 mph. High speed may cause loss of control. • Check local, state and federal requirements before towing on any public road.
<p>TOWING LOG SPLITTER</p> <ul style="list-style-type: none"> • Lock beam in horizontal position. • Attach coupler to Class I or higher hitch with 2" ball. Latch securely. 	

1

Safety Labels



WARNING

DO NOT remove safety (or any) labels from log splitter for any reason.

2

Safe Operation Practices



WARNING

This symbol points out important safety instructions which, if not followed, could endanger the personal safety and/or property of yourself and others. Read and follow all instructions in this manual before attempting to operate this machine. Failure to comply with these instructions may result in personal injury. When you see this symbol -

HEED ITS WARNING

Your Responsibility

Restrict the use of this power machine to persons who read, understand and follow the warnings and instructions in this manual.



WARNING: Engine Exhaust, some of its constituents, and certain vehicle components contain or emit chemicals known to State of California to cause cancer and birth defects or other reproductive harm.

DANGER: This machine was built to be operated according to the rules for safe operation in this manual. As with any type of power equipment, carelessness or error on the part of the operator can result in serious injury. This machine is capable of amputating hands and feet and throwing objects. Failure to observe the following safety instructions could result in serious injury or death.

General Practices

1. Read, understand, and follow all instructions on the machine and in the manual(s) before attempting to assemble and operate. Keep this manual in a safe place for future and regular reference and for ordering replacement parts.
2. Be familiar with all controls and proper operation. Know how to stop the machine and disengage them quickly.
3. Never allow children under 16 years to operate this machine. Children, 16 years and over, should read and understand instructions and safety rules in this manual and should be trained and supervised by a parent.
4. Never allow adults to operate this machine without proper instruction.
5. Many accidents occur when more than one person operates the machine. If a helper is assisting in loading logs, never activate the control until the helper is a minimum of 10 feet from the machine.
6. Keep bystanders, helpers, pets, and children at least 20 feet from the machine while it is in operation.
7. Never allow anyone to ride on this machine.
8. Never transport cargo on this machine.
9. Hydraulic log splitters develop high fluid pressures during operation. Fluid escaping through a pin hole opening can penetrate your skin and cause blood poisoning, gangrene, or death. Give attention to the following instructions at all times:
 - a. Do not check for leaks with your hand.
 - b. Do not operate machine with frayed, kinked, cracked, or damaged hoses, fitting, or tubing.
 - c. Stop the engine and relieve hydraulic system pressure before changing or adjusting fittings, hoses, tubing, or other system components.
 - d. Do not adjust the pressure settings of the pump or valve.
10. Leaks can be detected by passing cardboard or wood, while wearing protective gloves and safety glasses, over the suspected area. Look for discoloration of cardboard or wood.
11. If injured by escaping fluid, see a doctor immediately. Serious infection or reaction can develop if proper medical treatment is not administered immediately.

12. Keep the operator zone and adjacent area clear for safe, secure footing.
13. If your machine is equipped with an internal combustion engine and it is intended for use near any unimproved forest, brush, or grass covered land, the engine exhaust should be equipped with a spark arrester. Make sure you comply with applicable local, state, and federal codes. Take appropriate firefighting equipment with you.
14. This machine should be used for splitting wood only, do not use it for any other purpose.
15. Follow the instructions in the manual(s) provided with any attachment(s) for this machine.

Preparation

1. Always wear safety shoes or heavy boots.
2. Always wear safety glasses or safety goggles during operating this machine.
3. Never wear jewelry or loose clothing that might become entangled in moving or rotating parts of the machine.
4. Make sure machine is on level surface before operating.
5. Always block machine to prevent unintended movement, and lock in either horizontal or vertical position.
6. Always operate this machine from the operator zone(s) specified in the manual.
7. Logs should be cut with square ends prior to splitting.
8. Use log splitter in daylight or under good artificial light.
9. To avoid personal injury or property damage use extreme care in handling gasoline. Gasoline is extremely flammable and the vapors are explosive. Serious personal injury can occur when gasoline is spilled on yourself or your clothes which can ignite. Wash your skin and change immediately.
 - a. Use only an approved gasoline container.
 - b. Extinguish all cigarettes, cigars, pipes, and other sources of ignition.
 - c. Never fuel machine indoors.
 - d. Never remove gas cap or add fuel while the engine is hot or running.
 - e. Allow engine to cool at least two minutes before refueling.

- f. Never overfill the fuel tank. Fill tank to no more than 1/2 inch below bottom of filler neck to provide space for fuel expansion.
- g. Replace gasoline cap and tighten securely.
- h. If gasoline is spilled, wipe it off the engine and equipment. move machine to another area. Wait 5 minutes before starting the engine.
- i. Never store the machine or fuel container inside where there is an open flame, spark or pilot light as on a water heater, space heater, furnace, clothes dryer or other gas appliances.
- j. Allow machine to cool 5 minutes before storing.

Operation

1. Before starting this machine, review the "Safety Instructions". Failure to follow these rules may result in serious injury to the operator or bystanders.
2. Never leave this machine unattended with the engine running.
3. Do not operate machine while under the influence of alcohol, drugs, or medication.
4. Never allow anyone to operate this machine without proper instruction.
5. Always operate this machine with all safety equipment in place and working. Make sure all controls are properly adjusted for safe operation.
6. Do not change the engine governor settings or overspeed the engine. The governor controls the maximum safe operating speed of the engine.
7. When loading a log, always place your hands on the sides of the log, not on the ends, and never use your foot to help stabilize a log. Failure to do so, may result in crushed or amputated fingers, toes, hand, or foot.
8. Use only your hand to operate the controls.
9. Never attempt to split more than one log at a time unless the ram has fully extended and a second log is needed to complete the separation of the first log.
10. For logs which are not cut square, the least square end and the longest portion of the log should be placed toward the beam and wedge, and the square end placed toward the end plate.
11. When splitting in the vertical position, stabilize the log before moving the control. Split as follows:
 - a. Place log on the end plate and turn until it leans against the beam and is stable.
 - b. When splitting extra large or uneven logs, the log must be stabilized with wooden shims or split wood between the log and end plate or ground.
12. Always keep fingers away from any cracks that open in the log while splitting. They can quickly close and pinch or amputate your fingers.
13. Keep your work area clean. Immediately remove split wood around the machine so you do not stumble over it.
14. Never move this machine while the engine is running.

15. This machine should not be towed on any street, highway or public road without checking the existing federal, state, or local vehicle requirements. Any licensing or modifications such as taillights, etc., needed to comply, is the sole responsibility of the purchaser. If a "Statement of Origin" is required in your state, see your local dealer.
16. Do not tow machine faster than 45mph.
17. See Transporting the Log Splitter section in this manual for proper towing instructions once all federal, local, or state requirements are met.

Maintenance and Storage

1. Stop the engine, disconnect the spark plug and ground it against the engine before cleaning, or inspecting the machine.
2. Stop the engine and relieve hydraulic system pressure before repairing or adjusting fittings, hoses, tubing, or other system components.
3. To prevent fires, clean debris and chaff from the engine and muffler areas. If the engine is equipped with a spark arrester muffler, clean and inspect it regularly according to manufacturers instructions. Replace if damaged.
4. Periodically check that all nuts and bolts, hose clamps, and hydraulic fittings are tight to be sure equipment is in safe working condition.
5. Check all safety guards and shields to be sure they are in the proper position. Never operate with safety guards, shields, or other protective features removed.
6. The pressure relief valve is preset at the factory. Do not adjust the valve.
7. Never attempt to move this machine over hilly or uneven terrain without a tow vehicle or adequate help.
8. For your safety, replace all damaged or worn parts immediately with original equipment manufacturer's (O.E.M.) parts only. "Use of parts which do not meet the original equipment specifications may lead to improper performance and compromise safety!"
9. Do not alter this machine in any manner, alterations such as attaching a rope or extension to the control handle, or adding to the width or height of the wedge may result in personal injury.

Your Responsibility

Restrict the use of this power machine to persons who read, understand and follow the warnings and instructions in this manual and on the machine. Always follow directions on safety labels found on your equipment.

2

Safe Operation Practices



WARNING

This symbol points out important safety instructions which, if not followed, could endanger the personal safety and/or property of yourself and others. Read and follow all instructions in this manual before attempting to operate this machine. Failure to comply with these instructions may result in personal injury. When you see this symbol - **HEED ITS WARNING**

Your Responsibility

Restrict the use of this power machine to persons who read, understand and follow the warnings and instructions in this manual.

3

Setting Up Your Log Splitter



WARNING

Use extreme caution unpacking this machine. Some components are very heavy and will require additional people or mechanical handling equipment.



NOTE: All references in this manual to the left or right side of the log splitter is from the operating position only. Exceptions, if any, will be specified.

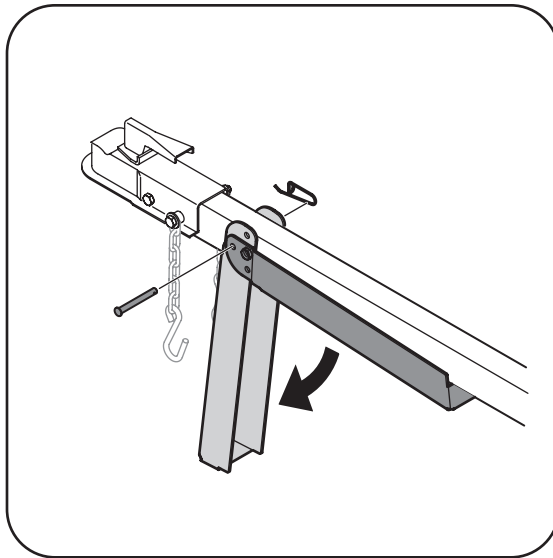

Figure 3-1

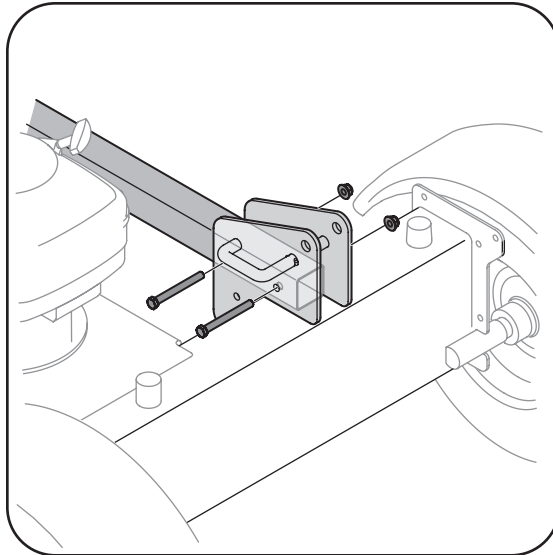

Figure 3-2

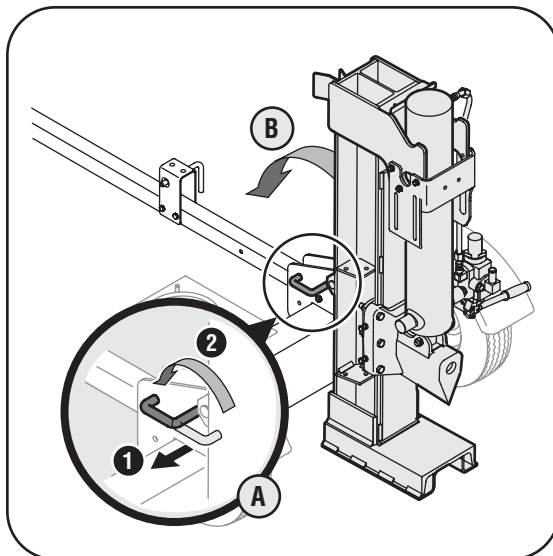

Figure 3-3



WARNING: Use extreme caution unpacking this machine. Some components are very heavy and will require additional people or mechanical handling equipment.

NOTE: All references in this manual to the left or right side of the log splitter is from the operating position only. Exceptions, if any, will be specified.

Assembling the Tongue

Attaching the Jack Stand

The jack stand is shipped in the transport position.

1. Remove the spring clip and clevis pin and pivot the jack stand towards the ground to the operating position.
2. Secure the jack stand in position with the clevis pin and spring clip. See Figure 3-1.

Attaching the Tongue

1. With the log splitter still standing upright, remove two hex bolts and hex nuts from the end of the tongue. See Figure 3-2.
2. Align the holes in the tongue with the holes in the tank bracket and secure with hardware just removed. See Figure 3-2.

NOTE: High pressure hose must be above the tongue assembly.

Connecting Cylinder to Beam

The log splitter is shipped with the beam in the vertical position.

1. Pull out the vertical beam lock, rotate it back, and pivot the beam to the horizontal position until it locks. See Figure 3-3.
2. Disconnect the dislodger from the beam weld bracket by removing the six hex screws. See Figure 3-4.

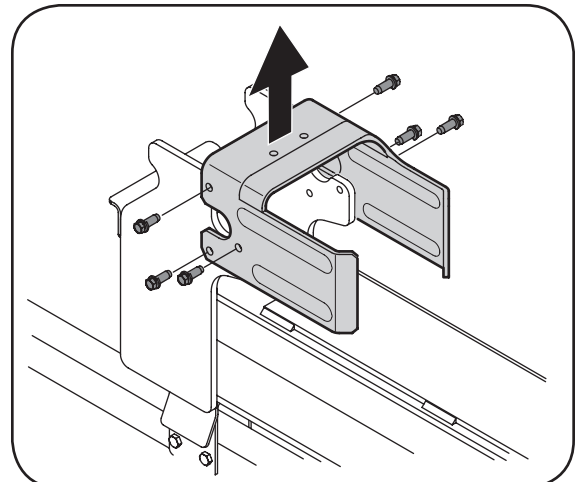

Figure 3-4

3. Disconnect the log cradle from the beam on the side of the control valve. See Figure 3-5.
4. Lift and slide the cylinder up to the top of beam and into the weld brackets. See Figure 3-6.
5. Attach the dislodger over the wedge assembly and secure with hardware, previously removed, to the weld brackets.

NOTE: Once the six hex screws are tightened, there may be a slight gap between the dislodger and the weld brackets. This gap is normal.

6. Reattach the log cradle to the side of the beam with the control valve, aligning the ends of the cradle with the beam flanges.
7. Roll log splitter off the bottom crate.

Preparing the Log Splitter

1. Lubricate the beam area (where the splitting wedge will slide) with engine oil; do not use grease.
2. Remove vented reservoir dipstick, which is located in front of the engine on top of the reservoir tank. See Figure 3-7.

IMPORTANT: The log splitter may have been shipped and primed with hydraulic fluid in the reservoir tank. If not, proceed with the following steps:

3. Fill the reservoir tank with hydraulic fluid included with this unit (if equipped) or approved fluids which include Dexron® III / Mercon® III automatic transmission fluid, a 10 Weight AW hydraulic oil or Pro-Mix™ AW-32 Hydraulic Oil.
4. Check fluid level using the dipstick. See Figure 3-7. Do not overfill.
5. Replace vented dipstick securely, tightening it until the top of the threads are flush with top of the pipe.
6. Disconnect the spark plug and prime the pump by pulling the recoil starter as far as it will go. Repeat approximately 10 times.
7. Reconnect the spark plug wire and start engine following instructions in the OPERATION section.
8. Use control handle to engage the wedge to the farthest extended position. Then retract the wedge.
9. Refill tank as specified on the dipstick.

NOTE: Failure to refill the tank will void unit's warranty. Extend and retract the wedge 12 complete cycles to remove trapped air in the system (the system is "self-bleeding").

11. Refill reservoir within range marked on the dipstick.

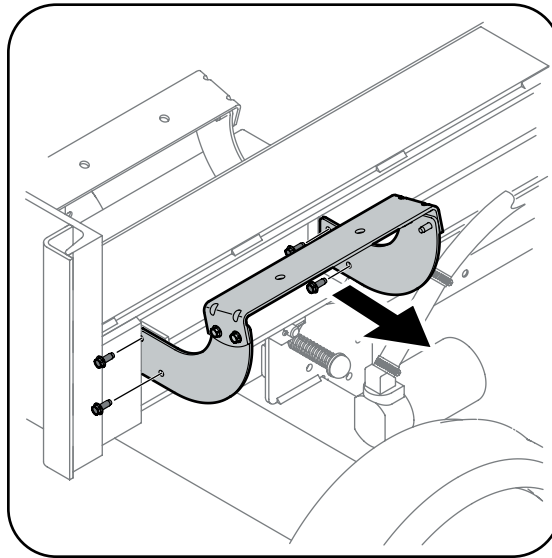

Figure 3-5

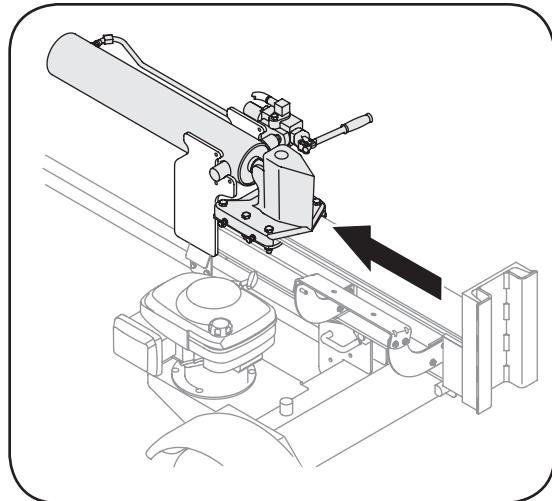

Figure 3-6

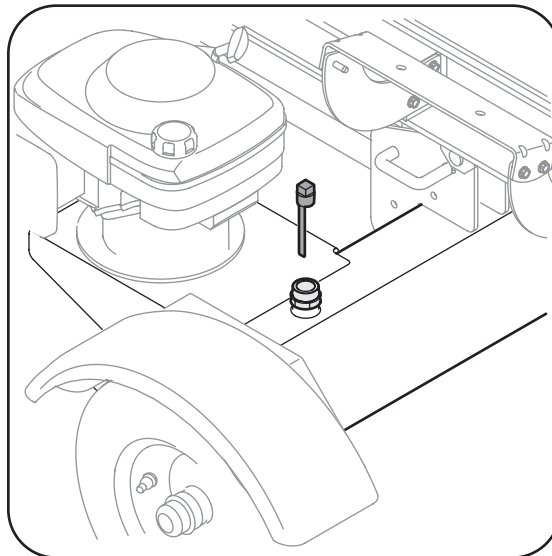

Figure 3-7

NOTE: Some fluid may overflow from the vent plug as the system builds heat and the fluid expands and seeks a balanced level.

3

Setting Up Your Log Splitter



WARNING

Much of the original fluid has been drawn into the cylinder and hoses. Make certain to refill the reservoir to prevent damage to the hydraulic pump.



IMPORTANT:

The log splitter may have been shipped and primed with hydraulic fluid in the reservoir tank. If not, proceed with the following steps:

NOTE: Some fluid may overflow from the vent plug as the system builds heat and the fluid expands and seeks a balanced level.



WARNING: Much of the original fluid has been drawn into the cylinder and hoses. Make certain to refill the reservoir to prevent damage to the hydraulic pump.

4

Operating Your Log Splitter



WARNING



IMPORTANT

Your log splitter is shipped with motor oil in the engine. However, you **MUST** check the oil level before operating. Be careful not to overfill.

Know Your Log Splitter

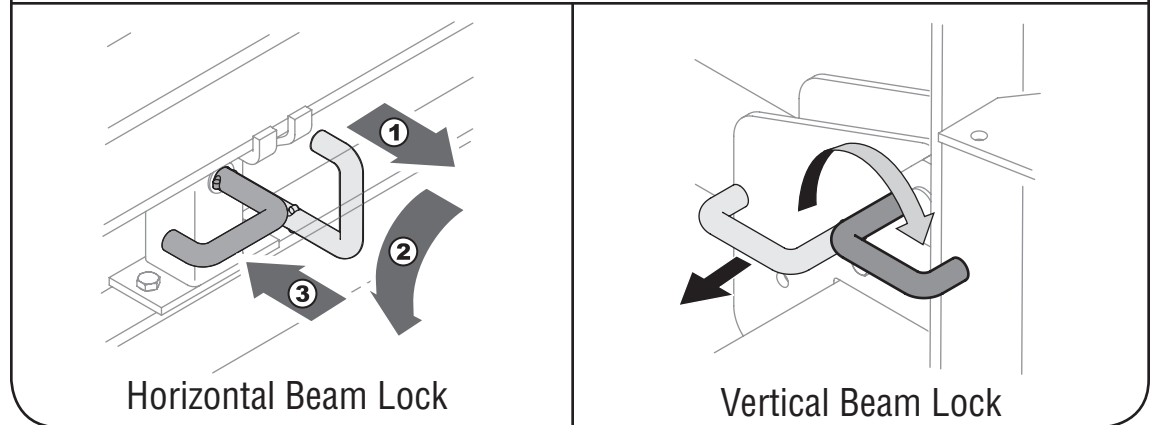
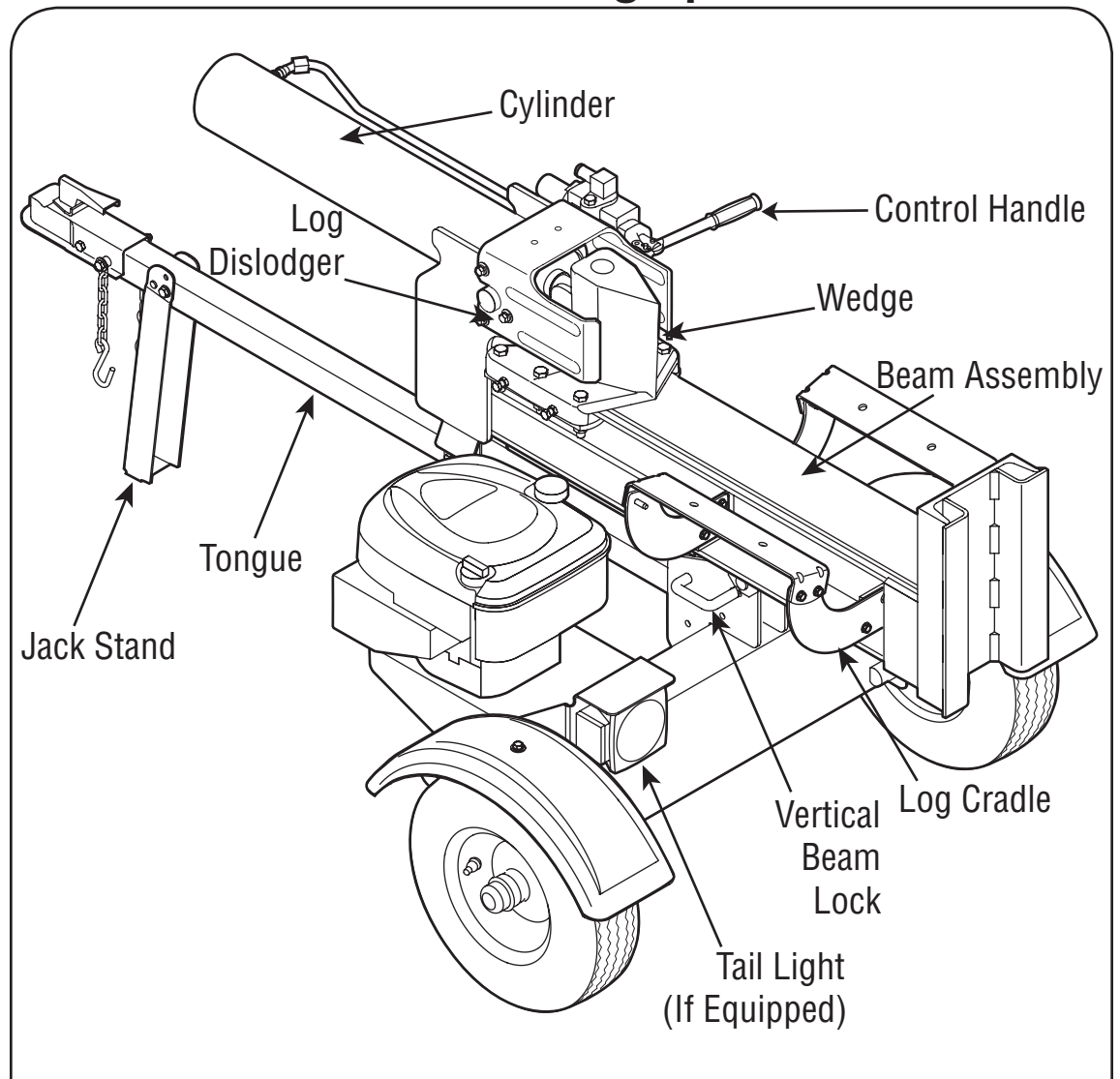

Figure 4-1

Beam Locks

These two locks, as their name suggests, are used to secure the beam in the horizontal or the vertical position. The vertical beam lock is located next to the oil filter. The horizontal beam lock is located on the beam support latch bracket. See Figure 4-1.

Engine Controls

See the accompanying engine manual for the location and function of the controls on the engine.

Control Handle

The control handle has three positions. See Figure 4-2.

- **FORWARD:** Move control handle FORWARD or DOWN to move wedge to split wood.

NOTE: Control handle will return to neutral position as soon as handle is released. **(Forward Position only)**

- **NEUTRAL:** Release the control handle or move the lever to neutral position to stop the wedge movement.
- **REVERSE:** Move control handle BACK or UP to return the wedge toward the cylinder. The control handle stays in the return (Reverse) position and returns to neutral automatically when fully retracted.

NOTE: Reverse position may also be operated back to neutral position manually, if necessary.

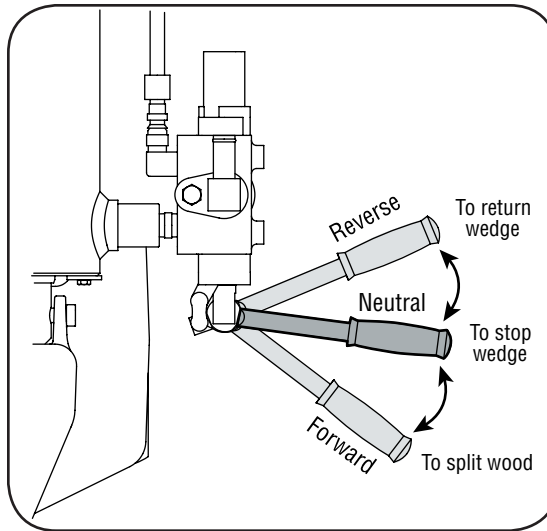

Figure 4-2

Stopping Engine

1. Move throttle control handle to STOP or OFF position.
2. Turn off the engine switch, if so equipped.
3. Disconnect spark plug wire and ground against the engine to prevent unintended starting.

IMPORTANT: Your log splitter may be shipped with motor oil in the engine. You **MUST** check the oil level before operating. Be careful not to overfill.



WARNING: Read, understand, and follow all instructions and warnings on the machine and in this manual before operating.



WARNING: Wear leather work gloves, safety shoes, ear protection, and safety glasses when operating a log splitter. Ensure safe footing.

Gas and Oil Fill-Up

1. Service the engine with gasoline and oil as instructed in the engine manual packed with your log splitter. Read instructions carefully.



WARNING: Use extreme care when handling gasoline. Gasoline is extremely flammable and the vapors are explosive. Never fuel machine indoors or while the engine is hot or running.



WARNING: When starting a warm engine, the muffler and surrounding areas are hot and can cause a burn. Do not touch.

4

Operating Your Log Splitter



WARNING

Read, understand, and follow all instructions and warnings on the machine and in this manual before operating.

Wear leather work gloves, safety shoes, ear protection, and safety glasses when operating a log splitter. Ensure safe footing.

Use extreme care when handling gasoline. Gasoline is extremely flammable and the vapors are explosive. Never fuel machine indoors or while the engine is hot or running.

When starting a warm engine, the muffler and surrounding areas are hot and can cause a burn. Do not touch.

4

Operating Your Log Splitter



WARNING

Never remove partially split wood from the wedge with your hands. Fingers may become trapped between split wood.

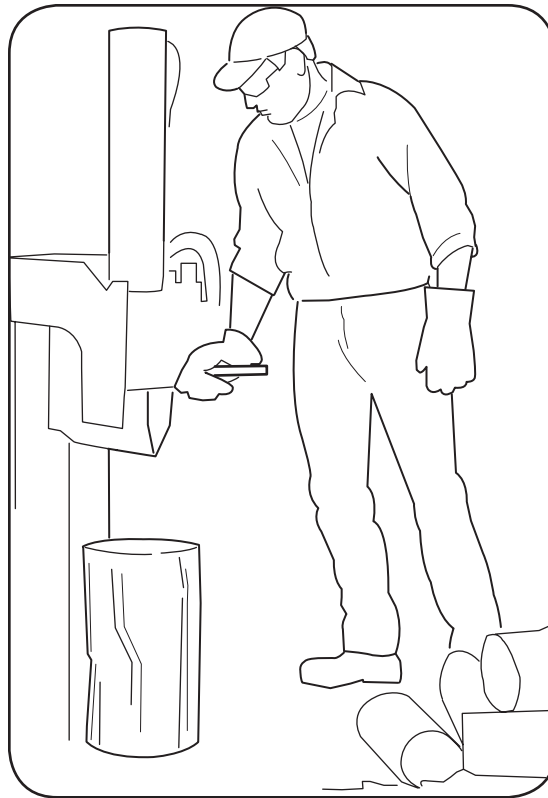

Figure 4-3

Before Each Use

1. Remove the dipstick and check hydraulic fluid level. Refill if necessary. Approved fluids include Dexron® III / Mercon® III automatic transmission fluid, a 10 Weight AW hydraulic oil or Pro-Mix™ AW-32 Hydraulic Oil.
2. Check engine oil level. Refill if necessary.
3. Fill up gasoline if necessary.
4. Lubricate the beam area where splitting wedge will slide with engine oil. Do not use grease to lubricate. Make sure to lubricate both the front and the back of the beam face.
5. Attach spark plug wire to the spark plug.

Using the Log Splitter

1. Place the log splitter on level, dry ground.
2. Place the beam in either the horizontal or vertical position and lock in place with the appropriate locking rod.
3. Block the front and back of both wheels.
4. Place the log against the end plate and only split wood in the direction of the grain.
5. To stabilize the log, place your hand only on sides of log. **Never place hand on the end between the log and the splitting wedge.**
6. Only one adult should stabilize the log and operate the control handle, so the operator has full control over the log and the splitting wedge.

Control Handle

1. Move control handle FORWARD or DOWN to split wood.
2. Release the control handle to stop the wedge movement.
3. Move control handle BACK or UP to return the wedge.

Log Dislodger

The log dislodger is designed to remove any partially split wood from the wedge. This may occur while splitting large diameter wood or freshly cut wood.



WARNING: Never remove partially split wood from the wedge with your hands. Fingers may become trapped between split wood.

1. To remove partially split wood from wedge, move control handle to REVERSE position until wedge is fully retracted to allow split wood portion to contact the log dislodger.
2. Once removed from wedge with log dislodger, split wood from opposite end or in another location.

Vertical Position

1. Pull the horizontal beam lock out to release the beam and pivot the beam to the vertical position.
2. To lock the beam in the vertical position, pull out on the vertical beam lock and rotate it to secure the beam. See Figure 4-1.
3. Stand in front of the unit to operate the control handle and to stabilize the log. See Figure 4-3.

Horizontal Position

1. Pull the vertical beam lock out and rotate it down. See Figure 4-1. Pivot beam to the horizontal position. The beam will lock automatically in horizontal position.
2. Stand behind the reservoir tank to operate control handle and to stabilize the log.

Operating Tips

Always:

1. Use clean fluid and check fluid level regularly.
2. Use an approved hydraulic fluid. Approved fluids include Dexron® III / Mercon® III automatic transmission fluid, a 10 Weight AW hydraulic oil or Pro-Mix™ AW-32 Hydraulic Oil.
3. Use a filter (clean or replace regularly).
4. Use a breather cap on fluid reservoir.
5. Make sure pump is mounted and aligned properly.

6. Use a flexible "spider" type coupling between engine and pump drive shafts.
7. Keep hoses clear and unblocked.
8. Bleed air out of hoses before operating.
9. Flush and clean hydraulic system before restarting after servicing.
10. Use "pipe dope" on all hydraulic fittings.
11. Allow time for warm-up before splitting wood.
12. Prime the pump before initial start-up by turning over the engine with spark plug disconnected.
13. Split wood along the grain (lengthwise) only.

Never:

1. Use when fluid is below 20° F or above 150° F.
2. Use a solid engine /pump coupling.
3. Operate through relief valve for long.
4. Attempt to adjust unloading or relief valve settings without pressure gauges.
5. Operate with air in hydraulic system.
6. Use teflon tape on hydraulic fittings.
7. Attempt to cut wood across the grain.
8. Attempt to remove partially split wood from the wedge with your hands. Fully retract wedge to dislodge wood with log dislodger.

Raising and Lowering Beam

1. Use control handle to run wedge up and down beam 6 to 8 times to circulate the hydraulic fluid, which will warm and thin the fluid.

2. Place log splitter on a firm, level surface.

To raise the beam for vertical operation:

3. Pull out the vertical beam lock on the tongue.
4. Pivot beam lock down to release the beam.
5. Move the beam to the vertical position. Secure it with the beam lock on the reservoir tank assembly.



WARNING: Always use the log splitter in the vertical position when splitting heavy logs.

To lower the beam:

1. Pull out the horizontal beam lock on the reservoir tank.
2. Pivot beam lock down to release the beam.
3. Carefully pull back on beam and lower it to the horizontal position. The horizontal beam lock will lock automatically. See Figure 4-1.

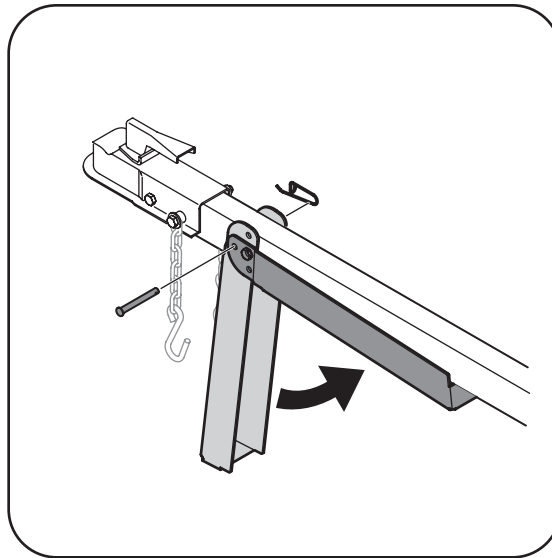

Figure 4-4

Transporting the Log Splitter

IMPORTANT: Always turn fuel valve to OFF position before transporting the log splitter.

1. Lower the beam to its horizontal position. Make certain the beam is locked securely with the horizontal beam lock.
2. Remove spring clip and clevis pin from jack stand.
3. Support the tongue and pivot the jack stand up against the tongue. See Figure 4-4.
4. Secure with the spring clip and clevis pin previously removed. See Figure 4-4.
5. Attach coupler hitch to a class I or higher 2" ball on a towing vehicle; latch securely.
 - a. **If coupler hitch does not fit on ball:** Turn adjustment nut one turn counter-clockwise.
 - b. **If coupler hitch is too loose on ball:** Turn adjustment nut one turn clockwise.
6. Connect the safety chains to the towing vehicle.
7. Plug in the tail lights, if so equipped, to the tail light connector on the tow vehicle.



WARNING: Do not tow faster than 45mph and check local, state, and federal requirements before towing on any public road.

NOTE: Use caution when backing up. It is recommended to use a spotter outside the vehicle.

4

Operating Your Log Splitter



WARNING

Always use the log splitter in the vertical position when splitting heavy logs.

Do not tow faster than 45mph and check local, state, and federal requirements before towing on any public road.

5

Maintaining Your Log Splitter



WARNING

Do not at any time make any adjustments without first stopping engine, disconnecting spark plug wire, and grounding it against the engine. Always wear safety glasses during operation or while performing any adjustments or repairs.

Before cleaning, lubricating, repairing, or inspecting, disengage the control lever and stop engine. Disconnect the spark plug wire and ground it against the engine to prevent unintended starting. Always wear safety glasses during operation or while performing any adjustments or repairs.

Higher pressure could cause the hoses to burst, cylinder to rupture, and intense fluid to be released, which could result in serious personal injury.

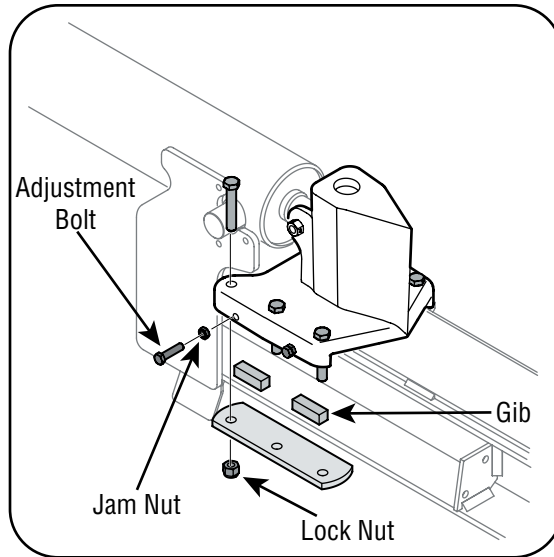

Figure 5-1



WARNING: Do not at any time make any adjustments without first stopping engine, disconnecting spark plug wire, and grounding it against the engine. Always wear safety glasses during operation or while performing any adjustments or repairs.

Wedge Assembly Adjustment

As normal wear occurs and there is excessive “play” between the wedge and beam, adjust the bolts on the side of the wedge assembly to eliminate excess space between the wedge and the beam.

1. Loosen the jam nuts on the two adjustment bolts on the side of the wedge. See Figure 5-1.
2. Turn the adjustment bolts in until snug and then back them off slowly (approximately 1.5 turns) until the wedge assembly will slide on the beam.
3. Re-tighten the jam nuts securely against the side of the wedge to secure the adjustment bolts in this position.

Gib Adjustment

Periodically remove and replace the “gibs” (spacers) between the wedge assembly and the back plate.

NOTE: The gibs may be rotated and/or turned over for even wear.

1. Loosen the lock nuts under each back plate and slide the gibs out. See Figure 5-1.
2. Turn or replace the gibs.
3. Reassemble the back plate and secure with the lock nuts.
4. Readjust the bolts on the side of the wedge assembly.



WARNING: Before cleaning, lubricating, repairing, or inspecting, disengage the control lever and stop engine. Disconnect the spark plug wire and ground it against the engine to prevent unintended starting. Always wear safety glasses during operation or while performing any adjustments or repairs.

Conditions that Will Void Warranty

1. Failure to maintain proper fluid level in reservoir
2. Changing the relief valve setting or pressure adjustment of control valve without proper knowledge and instruction from the factory
3. Disassembling the pump
4. Use of incorrect hydraulic fluid
5. Allowing the flexible pump coupler to deteriorate without proper and regular inspection
6. Lack of lubrication or improper lubrication of the beam or unit
7. Improper adjustment of splitting wedge
8. Excessive heating of the hydraulic system
9. Attempting to start unit in temperatures under 20°F without pre-heating fluid in reservoir
10. Unattended leaks in hydraulic system



WARNING: Higher pressure could cause the hoses to burst, cylinder to rupture, and intense fluid to be released, which could result in serious personal injury.

Hydraulic Fluid and Inlet Filter

- Check the hydraulic fluid level in the log splitter reservoir tank before each use. Maintain fluid level within the range specified on the dipstick at all times.
- Change the hydraulic fluid in the reservoir every 100 hours of operation. Follow the steps below:
 1. Disconnect the suction hose from the bottom of the reservoir tank.
 2. Carefully unthread the inlet filter and clean it with penetrating oil. See Figure 5-2.
 3. Allow the fluid to drain into a suitable container.
 4. Reinsert the filter and refill the reservoir with three gallons of oil. Approved fluids include Dexron® III / Mercon® III automatic transmission fluid, a 10 Weight AW hydraulic oil or Pro-Mix™ AW-32 Hydraulic Oil.
- Maintain fluid level within the range specified on the dipstick at all times.

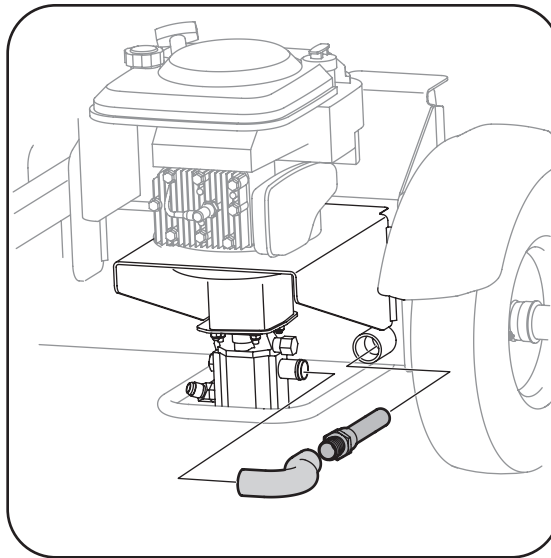

Figure 5-2

NOTE: Always dispose of used hydraulic fluid and engine oil at approved recycling centers only.

- Contaminants in fluid may damage the hydraulic components. Flushing the reservoir tank and hoses with kerosene whenever service is performed on the tank, hydraulic pump or valve is recommended. Contact an authorized service dealer.

Hydraulic Filter

- Change the hydraulic filter every 50 hours of operation. Use only a 10 micron hydraulic filter. Order part number 723-0405.

Beam and Splitting Wedge

- Lubricate both sides of the beam (where it comes into contact with the splitting wedge), before each use, with engine oil. The wedge plate on the log splitter is designed so the gibs on the side of the wedge plate can be removed and rotated and/or turned over for even wear.
- Make certain to readjust the adjustment bolts so wedge moves freely, but no excess space exists between the wedge plate and the beam.

Hose Clamps

- Check, before each use, if hose clamps on the suction hose (attached to the side of the pump) are tight. Check the hose clamps on the return hose at least once a season.

Engine

Refer to the separate engine manual for all maintenance instructions.

Flexible Pump Coupler

The flexible pump coupler is a nylon “spider” insert, located between the pump and the engine shaft. Over time, the coupler will harden and deteriorate.

Replace the coupler if you detect vibration or noise coming from the area between the engine and the pump. If the coupler fails completely, you will experience a loss of power.

IMPORTANT: Never hit the engine shaft in any manner, as a blow will cause permanent damage to the engine.

5

Maintaining Your Log Splitter



WARNING



NOTE: Always dispose of used hydraulic fluid and engine oil at approved recycling centers only.

IMPORTANT

Never hit the engine shaft in any manner, as a blow will cause permanent damage to the engine.

5

Maintaining Your Log Splitter



WARNING

Excessive pressure when seating beads may cause tire/rim assembly to burst with force sufficient to cause serious injury. Refer to sidewall of tire for recommended pressure.

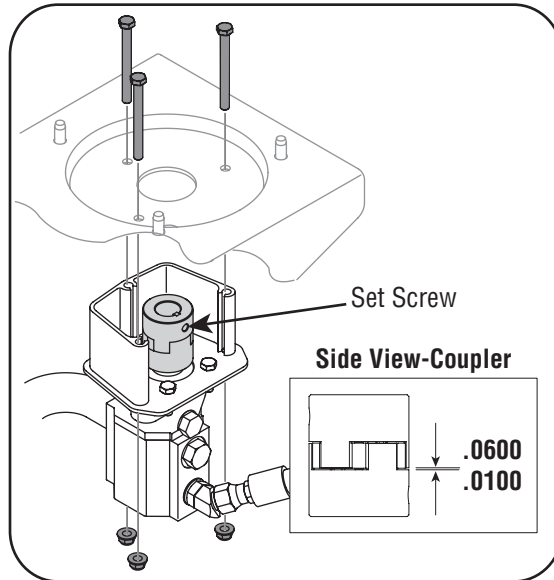

Figure 5-3

1. Remove three nuts that secure the pump to the coupling shield. Two nuts are at the bottom corners and one is in the top center. See Figure 5-3.
2. Remove the pump.
3. Rotate the engine by slowly pulling starter handle until engine coupling half set screw is visible. Loosen set screw using allen wrench and slide coupling half off engine shaft.
4. Loosen set screw on pump coupling half and remove coupling half.
5. Slide new engine coupling half onto the engine shaft until the end of the shaft is flush with the inner portion of the coupling half. (There must be space between the end of the engine support bracket and coupling half). Tighten set screw.

6. Install pump coupling half and key on pump shaft. Rotate coupling half until set screw faces opening in shield. Do not tighten set screw.
7. Install nylon "spider" onto engine coupling half.
8. Align pump coupling half with nylon "spider" by rotating engine using starter handle. Slide coupling half into place while guiding three mounting bolts through holes in pump support bracket.
9. Secure with nuts removed earlier.
10. Set .010" to .060" clearance/gap between the nylon "spider" and the engine coupling half by sliding a feeler gauge or matchbook cover between the nylon "spider" and the engine coupling half and moving pump coupling half as needed. Secure pump coupling half with set screw. See Figure 5-3.

NOTE: Make certain proper clearance/gap is obtained before tightening set screw.

Tires

See sidewall of tire for recommended pressure. Under any circumstances do not exceed manufacturer's recommended psi. Maintain equal pressure on all tires.



WARNING: Excessive pressure when seating beads may cause tire/rim assembly to burst with force sufficient to cause serious injury. Refer to sidewall of tire for recommended pressure.

Storing Your Log Splitter

Prepare your log splitter for storage at the end of the season or if the log splitter will not be used for 30 days or more.



WARNING: Never store machine with fuel in the fuel tank inside of building where fumes may reach an open flame or spark, or where ignition sources are present such as hot water and space heaters, furnaces, clothes dryers, stoves, electric motors, etc.

1. Clean the log splitter thoroughly.

NOTE: We do not recommend the use of pressure washers or garden hose to clean your unit. They may cause damage to bearings or the engine. The use of water will result in shortened life and reduce serviceability.

2. Wipe unit with an oiled rag to prevent rust, especially on the wedge and the beam.
3. Drain fuel tank. Always drain fuel into approved container outdoors, away from open flame. Be sure that engine is cool before draining the fuel. Do not smoke while handling fuel.

4. Start the engine and let it run until the fuel lines and carburetor are empty.
5. Remove spark plug. Holding a rag over the cylinder hole, pour approximately 1/2 ounce (approximately one tablespoon) of engine oil into cylinder and crank slowly to distribute the oil.
6. Replace spark plug.
7. Do not store gasoline from one season to another.
8. Replace your gasoline can if it starts to rust. Rust and/or dirt in the gasoline will cause problems.
9. Store unit in a clean, dry area. Do not store next to corrosive materials, such as fertilizer.

NOTE: If storing in an unventilated or metal storage shed, be certain to rustproof the equipment by coating with a light oil or silicone.

5

Maintaining Your Log Splitter



WARNING

Never store machine with fuel in the fuel tank inside of building where fumes may reach an open flame or spark, or where ignition sources are present such as hot water and space heaters, furnaces, clothes dryers, stoves, electric motors, etc.



NOTE: We do not recommend the use of pressure washers or garden hose to clean your unit. They may cause damage to bearings or the engine. The use of water will result in shortened life and reduce serviceability.

6

Trouble Shooting



For repairs beyond the minor adjustments listed here, contact an authorized service dealer.

Problem	Cause	Remedy
Engine fails to start	<ol style="list-style-type: none"> 1. Spark plug wire disconnected. 2. Fuel tank empty or stale fuel. 3. Choke, if equipped, not in CHOKE position. 4. Faulty spark plug. 5. Blocked fuel line. 6. Engine (if equipped with a primer) not primed properly. 7. Throttle control lever not in correct starting position. 	<ol style="list-style-type: none"> 1. Connect wire to spark plug. 2. Fill tank with clean, fresh gasoline. 3. Move choke to CHOKE position. 4. Clean, adjust gap, or replace. 5. Clean fuel line. 6. Prime engine. 7. Move throttle lever to FAST position.
Engine runs erratic	<ol style="list-style-type: none"> 1. Unit running with CHOKE applied, if so equipped. 2. Spark plug wire loose. 3. Blocked fuel line or stale fuel. 4. Water or dirt in fuel system. 5. Dirty air cleaner. 6. Carburetor not adjusted properly. 	<ol style="list-style-type: none"> 1. Move choke lever to OFF position. 2. Connect and tighten spark plug wire. 3. Clean fuel line; fill tank with clean, fresh (less than 30 days old) gasoline. 4. Drain fuel tank. Refill with fresh fuel. 5. Clean or replace air cleaner. 6. See authorized service dealer.
Engine Overheats	<ol style="list-style-type: none"> 1. Engine oil level low. 2. Dirty air cleaner. 3. Carburetor not adjusted properly. 	<ol style="list-style-type: none"> 1. Fill crankcase with proper oil. 2. Clean or replace air cleaner. 3. See authorized service dealer.

Hydraulic Trouble Shooting

Problem	Cause	Remedy
Cylinder rod will not move	<ol style="list-style-type: none"> 1. Broken drive shaft. 2. Shipping plugs left in hydraulic hoses. 3. Set screws in coupling not adjusted properly. 4. Loose shaft coupling. 5. Gear sections damaged. 6. Damaged relief valve. 7. Hydraulic lines blocked. 8. Incorrect oil level. 9. Damaged directional valve. 10. Blocked directional valve. 	<ol style="list-style-type: none"> 1. See authorized service dealer. 2. Disconnect hydraulic hoses, remove shipping plugs, reconnect hoses. 3. See operator's manual for correct adjustment. 4. Correct engine/pump alignment as necessary. 5. See authorized service dealer. 6. See authorized service dealer. 7. Flush and clean hydraulic system. 8. Check oil level. 9. See authorized service dealer. 10. Flush and clean hydraulic system.

Problem	Cause	Remedy
Slow cylinder shaft speed while extending and retracting.	<ol style="list-style-type: none"> 1. Gear sections damaged. 2. Excessive pump inlet vacuum. 3. Slow engine speed. 4. Damaged relief valve. 5. Incorrect oil level. 6. Contaminated oil. 7. Directional valve leaking internally. 8. Internally damaged cylinder. 	<ol style="list-style-type: none"> 1. See authorized service dealer. 2. Make certain pump inlet hoses are clear and unblocked-use short, large diameter inlet hoses. 3. See authorized service dealer. 4. See authorized service dealer. 5. Check oil level. 6. Drain oil, clean reservoir, and refill. 7. See authorized service dealer. 8. See authorized service dealer.
Leaking Cylinder	<ol style="list-style-type: none"> 1. Broken seals. 2. Scored cylinder. 	<ol style="list-style-type: none"> 1. See authorized service dealer. 2. See authorized service dealer.
Engine runs but wood will not split or wood splits too slowly	<ol style="list-style-type: none"> 1. Small gear section damaged. 2. Pump check valve leaking. 3. Excessive pump inlet vacuum. 4. Incorrect oil level. 5. Contaminated oil. 6. Directional valve leaking internally. 7. Overloaded cylinder. 8. Internally damaged cylinder. 	<ol style="list-style-type: none"> 1. See authorized service dealer. 2. See authorized service dealer. 3. Make certain pump inlet hoses are clear and unblocked. 4. Check oil level. 5. Drain oil, clean reservoir, and refill. 6. See authorized service dealer. 7. Do not attempt to split wood against the grain. 8. See authorized service dealer.
Engine stalls during splitting	<ol style="list-style-type: none"> 1. Low horsepower/weak engine. 2. Overloaded cylinder. 	<ol style="list-style-type: none"> 1. See authorized service dealer. 2. Do not attempt to split wood against the grain or see authorized service dealer.
Engine will not turn or stalls under low load conditions	<ol style="list-style-type: none"> 1. Engine/pump misalignment. 2. Frozen or seized pump. 3. Low horsepower/weak engine. 4. Hydraulic lines blocked. 5. Blocked directional valve. 	<ol style="list-style-type: none"> 1. Correct alignment as necessary. 2. See authorized service dealer. 3. See authorized service dealer. 4. Flush and clean hydraulic system. 5. Flush and clean hydraulic system.
Leaking pump shaft seal	<ol style="list-style-type: none"> 1. Broken drive shaft. 2. Engine/pump misalignment. 3. Gear sections damaged. 4. Poorly positioned shaft seal. 5. Plugged oil breather. 	<ol style="list-style-type: none"> 1. See authorized service dealer. 2. Correct alignment as necessary. 3. See authorized service dealer. 4. See authorized service dealer. 5. Make certain reservoir is properly vented.

6

Hydraulic Trouble Shooting



For repairs beyond the minor adjustments listed here, contact an authorized service dealer.

Model 510

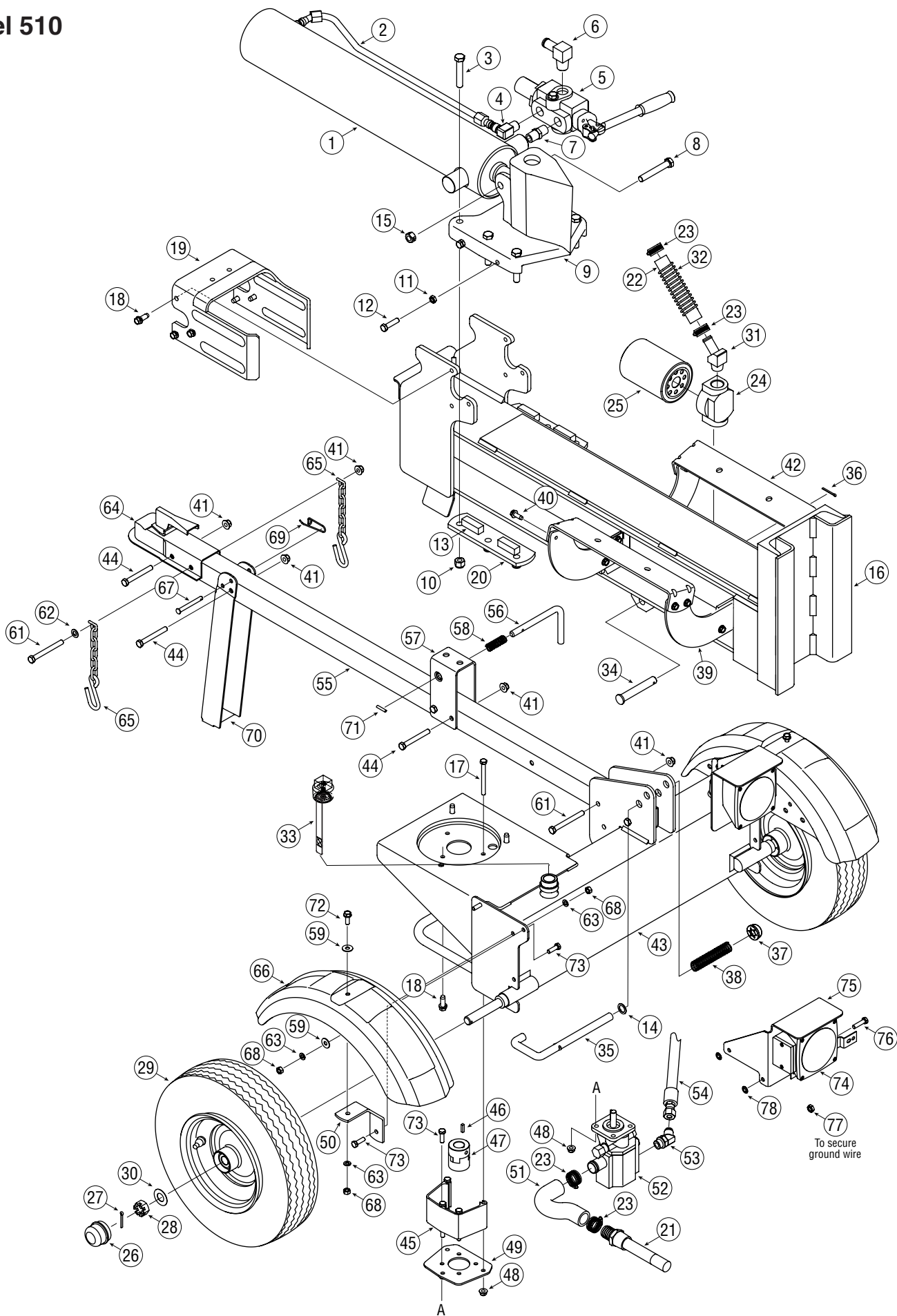

1.	718-0769A	Hydraulic Cylinder
2.	727-0634	Hydraulic Tube
3.	710-1018	Hex Cap Screw 1/2-20 x 2.75
4.	737-0192	90 Degree Solid Adapter
5.	718-0481	Control Valve
6.	737-0153	Return Elbow
7.	737-0238	Nipple Pipe 1/2-14
8.	710-1806	Hex Cap Screw 1/2-13 x 3.25
9.	719-0550A	Wedge Assembly
10.	712-3058	Hex Lock Nut, 1/2-20
11.	712-0711	Hex Jam Nut 3/8-24
12.	710-0459A	Hex Cap Screw 3/8-24 x 1.5
13.	781-0351	Adjustable Gib
14.	736-0116	Flat Washer.635 x.93 x.06
15.	712-3022	Hex Lock Nut 1/2-13
16.	681-04071	Beam Assembly
17.	710-3056	Hex Screw, 5/16-18 x 3.25
18.	710-0654A	Hex Washer Screw 3/8-16 x 1.0
19.	781-1048A	Dislodger Bracket
20.	781-0790	Back Plate
21.	737-04093	Inlet Filter
22.	727-0443	Return Hose 3/4" ID x 44" Lg.
23.	726-0132	Hose Clamp 5/8"
24.	737-0316	Filter Housing
25.	723-0405	Oil Filter
26.	734-0873	Hub Cap
27.	714-0162	Cotter Pin
28.	712-0359	Slotted Nut 3/4-16
29.	634-0186	Wheel Assembly
30.	736-0351	Flat Washer.760 ID x.500 OD
31.	737-0312	Adapter 3/4-14
32.	781-0526A	Hose Guard
33.	737-0348A	Vented Dipstick
34.	711-1587	Clevis Pin
35.	781-0690	Lock Rod
36.	714-0470	Cotter Pin
37.	726-0214	Push Cap
38.	732-0583	Compression Spring
39.	781-04180	Log Tray Bracket
40.	710-0650	TT Screw, 5/16-18 x.875

41.	712-04065	Flange Lock Nut, 3/8-16
42.	781-04129	Log Tray
43.	681-04040	Frame Assembly
44.	710-0521	Hex Bolt 3/8-16 x 3"
45.	719-0353	Coupling Shield
46.	714-0122	Square Key 3/16" x.75
47.	718-04145	Flexible Coupling
48.	712-04063	Flange Lock Nut, 5/16-18
49.	781-0097	Rear Coupling Support Bracket
50.	781-1024	Fender Mounting Bracket
51.	727-04130	Hose
52.	718-04127	Gear Pump
53.	737-0329	45 Degree Elbow Fitting
54.	727-0502	High Pressure Hydraulic Hose
55.	781-0788	Tongue Assembly
56.	747-1261	Latch Rod
57.	781-1045	Latch
58.	732-3127	Compression Spring
59.	736-0371	Flat Washer
60.	781-0538A	Hose Guard
61.	710-3085	Hex Cap Screw, 3/8-16 x 3.50
62.	736-0185	Flat Washer,.375 x.738 x.063
63.	736-0119	Lock Washer
64.	681-04030	Hitch Coupling Assembly
65.	713-0433A	Chain
66.	731-2496A	Fender
67.	711-0813	Clevis Pin
68.	712-3010	Hex Nut 5/16-18
69.	732-0194	Spring Pin
70.	781-0789	Jack Stand
71.	715-0120	Spiral Pin
72.	710-1238	Hex Bolt 5/16-18 x 0.875"
73.	710-0376	Hex Screw, 5/16-18 x 1.00
74.	625-0062†	Light Kit
75.	681-0164†	Light Bracket - LH
	781-1027†	Light Bracket - RH
76.	710-0874†	Screw, 5/16-18 x 1.25
77.	712-3008†	Jam Nut, 3/8-16
78.	726-0201†	Speed Nut, .3125 ID

† If Equipped

7

Parts List



To order replacement parts, call
1-800-800-7310
 or visit
www.whiteoutdoor.com

MANUFACTURER'S LIMITED WARRANTY FOR



The limited warranty set forth below is given by MTD LLC with respect to new merchandise purchased and used in the United States, its possessions and territories.

"MTD" warrants this product against defects in material and workmanship for a period of two (2) years commencing on the date of original purchase and will, at its option, repair or replace, free of charge, any part found to be defective in materials or workmanship. This limited warranty shall only apply if this product has been operated and maintained in accordance with the Operator's Manual furnished with the product, and has not been subject to misuse, abuse, commercial use, neglect, accident, improper maintenance, alteration, vandalism, theft, fire, water, or damage because of other peril or natural disaster. Damage resulting from the installation or use of any part, accessory or attachment not approved by MTD for use with the product(s) covered by this manual will void your warranty as to any resulting damage.

Normal wear parts are warranted to be free from defects in material and workmanship for a period of thirty (30) days from the date of purchase. Normal wear parts include, but are not limited to items such as: batteries, belts, blades, blade adapters, grass bags, rider deck wheels, seats, snow thrower skid shoes, shave plates, auger spiral rubber and tires.

HOW TO OBTAIN SERVICE: Warranty service is available, WITH PROOF OF PURCHASE, through your local authorized service dealer. To locate the dealer in your area, check your Yellow Pages, or contact MTD LLC at P.O. Box 361131, Cleveland, Ohio 44136-0019, or call 1-800-949-4483 or log on to our Web site at www.whiteoutdoor.com.

This limited warranty does **not** provide coverage in the following cases:

- a. The engine or component parts thereof. These items may carry a separate manufacturer's warranty. Refer to applicable manufacturer's warranty for terms and conditions.
- b. Log splitter pumps, valves, and cylinders have a separate one year warranty.
- c. Routine maintenance items such as lubricants, filters, blade sharpening, tune-ups, brake adjustments, clutch adjustments, deck adjustments, and normal deterioration of the exterior finish due to use or exposure.
- d. Service completed by someone other than an authorized service dealer.

- e. MTD does not extend any warranty for products sold or exported outside of the United States, its possessions and territories, except those sold through MTD's authorized channels of export distribution.
- f. Replacement parts that are not genuine MTD parts.
- g. Transportation charges and service calls.

No implied warranty, including any implied warranty of merchantability of fitness for a particular purpose, applies after the applicable period of express written warranty above as to the parts as identified. No other express warranty, whether written or oral, except as mentioned above, given by any person or entity, including a dealer or retailer, with respect to any product, shall bind MTD. During the period of the warranty, the exclusive remedy is repair or replacement of the product as set forth above.

The provisions as set forth in this warranty provide the sole and exclusive remedy arising from the sale. MTD shall not be liable for incidental or consequential loss or damage including, without limitation, expenses incurred for substitute or replacement lawn care services or for rental expenses to temporarily replace a warranted product.

Some states do not allow the exclusion or limitation of incidental or consequential damages, or limitations on how long an implied warranty lasts, so the above exclusions or limitations may not apply to you.

In no event shall recovery of any kind be greater than the amount of the purchase price of the product sold. **Alteration of safety features of the product shall void this warranty.** You assume the risk and liability for loss, damage, or injury to you and your property and/or to others and their property arising out of the misuse or inability to use the product.

This limited warranty shall not extend to anyone other than the original purchaser or to the person for whom it was purchased as a gift.

HOW STATE LAW RELATES TO THIS WARRANTY: This limited warranty gives you specific legal rights, and you may also have other rights which vary from state to state.

IMPORTANT: Owner must present Original Proof of Purchase to obtain warranty coverage.