

# OWNER'S GUIDE

ASSEMBLY • OPERATION • MAINTENANCE • PARTS

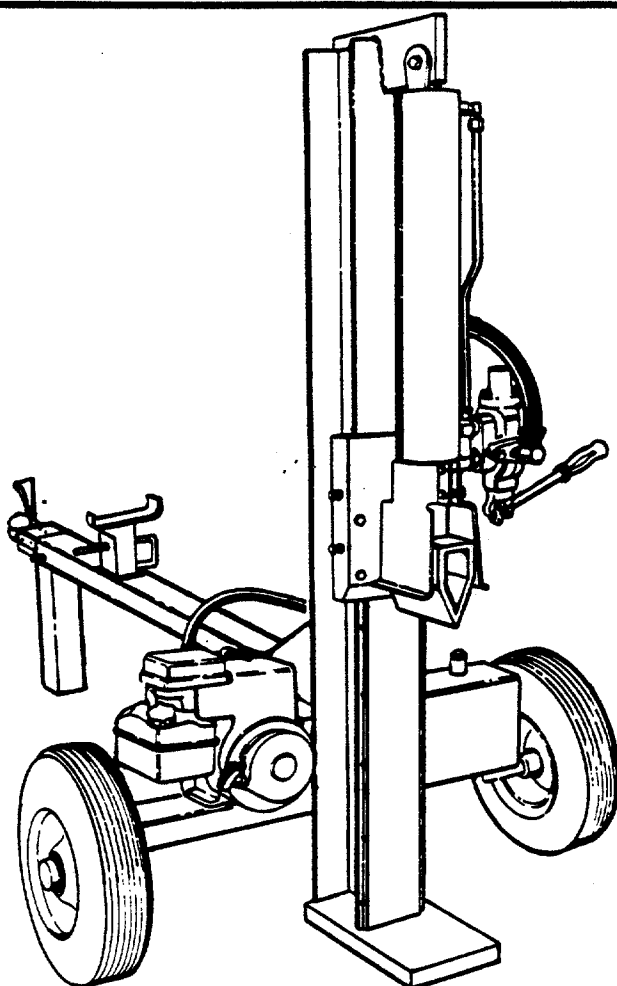

## LOG SPLITTER

Model Number  
241-521-000

**Important: Read Safety Rules and Instructions Carefully**



**WARNING:** This unit is equipped with an internal combustion engine and should not be used on or near any unimproved forest-covered, brush-covered or grass-covered land unless the engine's exhaust system is equipped with a spark arrester meeting applicable local or state laws (if any). If a spark arrester is used, it should be maintained in effective working order by the operator.

In the State of California the above is required by law (Section 4442 of the California Public Resources Code). Other states may have similar laws. Federal laws apply on federal lands. A spark arrester for the muffler is available through your nearest engine authorized service dealer or contact the service department, P.O. Box 360900, Cleveland, Ohio 44136.

# IMPORTANT INFORMATION FOR LOG SPLITTER USERS

## ALWAYS:

- Use clean fluid and check fluid level regularly
- Use Dexron II Automatic Transmission Fluid or 10W non-foaming hydraulic fluid.
- Use a filter (clean or replace regularly)
- Use a breather cap on fluid reservoir
- Keep end of reservoir return tube below fluid level
- Make certain pump is mounted and aligned properly
- Use a flexible "spider" type coupling between engine and pump driveshafts
- Keep hoses clear and unblocked
- Bleed air out of hoses before operating
- Flush and clean hydraulic system before startup after any malfunction or servicing
- Use "pipe dope" on all hydraulic fittings
- Allow time for warmup before splitting wood
- Prime the pump before initial startup by turning over the engine with spark plug disconnected
- Split wood with the grain (lengthwise) only

## NEVER:

- Use fluid below 0° F., or above 150° F.
- Use a solid engine/pump coupling
- Force pump when mounting
- Operate through relief valve for more than several seconds
- Attempt to adjust unloading or relief valve settings without pressure gauges
- Operate with air in hydraulic system
- Use Teflon tape on hydraulic fittings
- Warm up engine apart from pump in cold weather
- Attempt to cut wood across the grain

## CONDITIONS WHICH WILL VOID YOUR WARRANTY

- Failure to maintain proper fluid level in reservoir** will void your warranty, causing permanent damage to pump by allowing air to be drawn into pump. Fluid will become foamy. Refer to "Initial Preparation" in the Operation Section of this manual.
- Changing the relief valve setting or pressure adjustment of control valve** without proper knowledge and instruction from the factory will void your warranty. A very minor adjustment could destroy the structural and safety limits for which the unit was designed. The system will produce more power than the structure will withstand. Higher pressure could cause the hoses to burst, cylinder to rupture and intense fluid releases, which could result in serious personal injury.
- Disassembling the pump** will void your warranty. If replacement is necessary, merely disconnect and replace. Do not attempt to adjust pump settings, as they are adjusted by the manufacturer at the factory.
- Use of incorrect hydraulic fluid** will void your warranty. Use only Dexron II automatic transmission fluid or 10W non-foaming hydraulic fluid.
- The flexible pump coupler must be inspected** regularly. Allowing the coupler to deteriorate will void your warranty. Deterioration of spider insert and prolonged use after deterioration will destroy pump bearings and engine bearings, along with total destruction of coupler hubs.
- Improper beam lubrication** will cause premature wear and looseness. Lubricate the beam regularly. Lack of lubrication will void your warranty.
- Improper adjustment of splitting wedge** will void your warranty. Become familiar with the proper tolerance required for adjustment of the splitting wedge as instructed in the adjustment section of this manual.
  - If wedge is too loose, cylinder beam and wedge wear will result. Allowing the wedge to loosen and be used under operating stress will cause damage which will not be covered under warranty.
  - If wedge is too tight, severe beam damage will result which will not be covered under warranty.
- Warranty card must be mailed** or delivered directly to factory. Proper information must be completed and mailed as per instructions. No warranty records on file may result in delay.
- Do not overheat the hydraulic system.** Excessive heat will destroy the hydraulic system with hardened O-rings and excessive friction.
- Do not attempt to start in temperatures under 20° F.** without pre-heating fluid in reservoir. Excessively cold fluid cannot circulate and draw into pump. Warranty will be void.
- Repair any leaks in hydraulic system immediately.** Unattended leaks will cause air to enter system and/or decrease fluid level in reservoir, causing damage to the hydraulic system which will not be covered by warranty.

# IMPORTANT

## RULES FOR SAFE OPERATION



THIS SYMBOL POINTS OUT IMPORTANT SAFETY INSTRUCTIONS WHICH, IF NOT FOLLOWED, COULD ENDANGER THE PERSONAL SAFETY AND/OR PROPERTY OF YOURSELF AND OTHERS. READ AND FOLLOW ALL INSTRUCTIONS IN THIS MANUAL BEFORE ATTEMPTING TO OPERATE YOUR LOG SPLITTER. FAILURE TO COMPLY WITH THESE INSTRUCTIONS MAY RESULT IN PERSONAL INJURY. WHEN YOU SEE THIS SYMBOL— HEED ITS WARNING.



### DANGER

Your log splitter was built to be operated according to the rules for safe operation in this manual. As with any type of power equipment, carelessness or error on the part of the operator can result in serious injury. If you violate any of these rules, you may cause serious injury to yourself or others.



### TRAINING

1. Before operating this splitter, read and understand this manual completely. Become familiar with it for your own safety. To fail to do so may cause serious injury. Do not allow anyone to operate your splitter who has not read this manual. Keep this manual in a safe place for future and regular reference and for ordering replacement parts.
2. Never use your splitter for any other purpose than splitting wood. It is designed for this use and any other use may cause an injury. Your log splitter is a precision piece of power equipment, not a playtoy. Therefore, exercise extreme caution at all times.
3. Never allow children to operate your log splitter. Do not allow adults to operate it without proper instruction. Only persons well acquainted with these rules of safe operation should be allowed to use your log splitter.
4. Only the operator is to be near your log splitter during use. Keep all others, including pets and children, a minimum of 20 feet away from your work zone. Flying wood can be hazardous. If a helper is assisting in loading logs, never activate the control until the helper is clear of the area. More accidents occur when more than one person operates the log splitter than at any other time.
5. No one should operate this unit while intoxicated or while taking medication that impairs the senses or reactions. A clear mind is essential for safety. Never allow a person who is tired or otherwise not alert to use your splitter.



### PREPARATION

1. Never wear loose clothing or jewelry that can be caught by moving parts of your log splitter and pull you into it. Keep clothing away from all moving parts of your log splitter.
2. Wear proper head gear to keep hair away from moving parts. Always wear protective hearing devices as needed.
3. Always wear safety shoes. A dropped log can seriously injure your foot.
4. Always wear safety glasses or goggles while operating your splitter. A piece of splitting log could fly off and hit your eyes.
5. If you wear gloves, be sure they are tight fitting without loose cuffs or draw strings.
6. Use your log splitter in daylight, or under good artificial light.
7. Never operate your splitter on slippery, wet, muddy or icy surfaces. Safe footing is essential in preventing accidents. Never operate your splitter while attached to a towing vehicle.

8. Only operate your splitter on level ground and not on the side of a hill. It could tip, or rolling logs or poor footing could cause an accident. Operating the splitter on level ground also prevents the spillage of gasoline from the fuel tank.
9. Never attempt to move the log splitter over hilly or uneven terrain without a tow vehicle or adequate help.
10. Always block the wheels to prevent movement of log splitter while in operation.
11. Check the fuel before starting the engine. Gasoline is an extremely flammable fuel. Do not fill the gasoline tank indoors, when the engine is running, or while the engine is still hot. Replace gasoline cap securely and wipe off any spilled gasoline before starting the engine as it may cause a fire or explosion.
12. Both ends of each log must be cut as square as possible to help prevent the log from riding out of the splitter during operation.



### OPERATION

1. Stand behind the reservoir tank when operating. See illustrations.

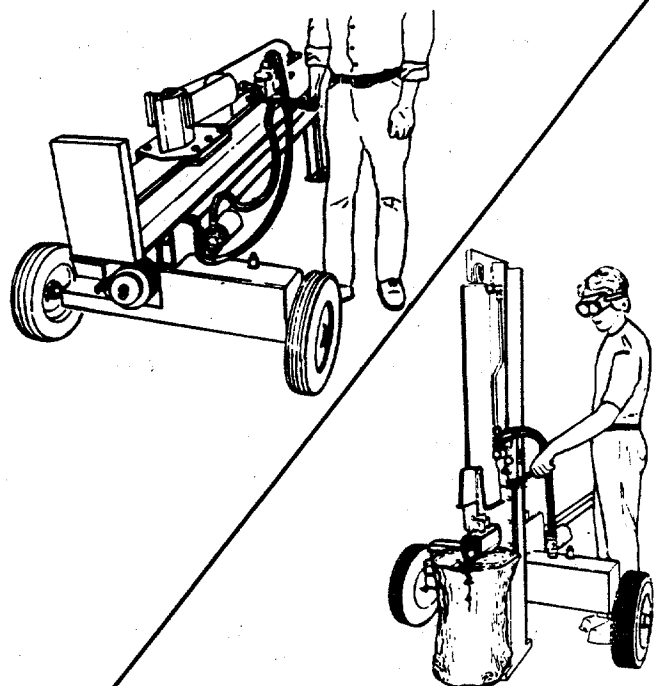

2. Know how to stop the unit and disengage the controls.
3. Never place hands or feet between log and splitting wedge or between log and end plate during forward or reverse stroke. To do so may result in crushed or amputated fingers or toes, or worse, you may lose an arm or foot.
4. Do not straddle the splitter when using it. A slip in any position could result in a serious injury.
5. Do not step over your log splitter when the engine is running. You may trip or accidentally activate the splitting wedge if you step over. If you need to get to the other side, walk around.
6. Never try to split two logs on top of each other. One may fly out and injure you.
7. When loading the log splitter, place your hands on the side of the log, not at the ends. Never attempt to load your splitter while the splitting wedge is in motion. You may get caught by the wedge and injured.
8. Only use your hand to operate the splitting wedge or control lever. Never use your foot or a rope or any other extension device. This could result in your ability to stop your splitter quickly enough and cause injury.
9. Always keep fingers away from any cracks that open in the log during splitting operation. They can quickly close and pinch or amputate your fingers.
10. Never attempt to split woods across the grain. Some types of wood may burst or fly out of your splitter and result in injury to you or a bystander.
11. For logs that are not cut square, the longest portion of the log should be rotated down and the most square end placed against the splitting wedge.
12. Keep your work area clean. Immediately remove split wood around your splitter so that you do not stumble over it. Clean chips and dirt off end plate (wood platform) after each log is split, or whenever necessary to maintain flat contact between wood and end plate (platform).
13. Never move the log splitter while the engine is running.
14. Never leave your log splitter unattended with the engine running. Shut off the engine if you are leaving your splitter, even for a short period of time. Someone could accidentally activate the splitting wedge and be injured.
15. Do not run engine in an enclosed area. Exhaust gases contain carbon monoxide. This odorless gas can be deadly when inhaled.
16. Be careful not to touch the muffler after the engine has been running as it is HOT.
17. If the equipment should start to vibrate abnormally, stop the engine and check immediately for the cause. Vibration is generally a warning of trouble.
18. When cleaning, repairing or inspecting, make certain all moving parts have stopped. Disconnect the spark plug wire and keep the wire away from the plug to prevent accidental starting



#### MAINTENANCE

1. Do not operate your splitter in poor mechanical condition or when in need of repair.
2. Periodically check that all nuts, bolts, screws, hose clamps and hydraulic fittings are tight to be sure equipment is in safe working condition. Where appropriate, check all safety guards and shields to be sure they are in the proper position. Never operate your splitter with safety guards, shields or other protective features removed. These safety devices are for your protection.

3. Replace all damaged or worn parts such as hydraulic hoses and fittings immediately with manufacturer approved replacement parts.
4. Do not change the engine governor settings or overspeed the engine. This increases the hazard of personal injury. The maximum engine speed is preset by the manufacturer and is within safety limits.
5. Do not alter your splitter in any manner such as attaching a rope or extension to the control lever or adding to the width or height of the wedge. Such alterations may cause your splitter to be unsafe.
6. Perform all recommended maintenance procedures before you use your splitter.
7. Do not service or repair your log splitter without disconnecting the spark plug wire.
8. Never store the equipment with gasoline in the tank inside of a building where ignition sources are present, such as hot water and space heaters, clothes dryers and the like. Allow the engine to cool before storing in any enclosure.
9. Always store gasoline in an approved, tightly sealed container. Store the container in a cool, dry place. Do not store in a building where ignition sources are present.
10. To reduce fire hazard, keep engine free of grass, leaves, wood chips, and excessive grease and oil.
11. The hydraulic system of your log splitter requires careful inspection, along with the mechanical parts. Be sure to replace frayed, kinked, or otherwise damaged hydraulic components.
12. Fluid escaping from a very small hole can be almost invisible. Do not check for leaks with your hand. Escaping fluid under pressure can have sufficient force to penetrate skin, causing serious personal injury. Leaks can be located by passing a piece of cardboard or wood over the suspected leak and looking for discoloration.
13. Should it become necessary to loosen or remove any hydraulic fitting or line, be sure to relieve all pressure by shutting off the engine and moving the control handle back and forth several times.
14. Do not remove the cap from the hydraulic tank or reservoir while your log splitter is running. Hot oil under pressure could cause injury.
15. The pressure relief valve on your splitter is preset at the factory. Do not adjust the valve. Only a qualified service technician should perform this adjustment.
16. Completely drain fuel tank prior to storage. This guards against accumulation of fuel fumes which could result in a fire hazard.
17. Never store log splitter outside without a waterproof cover. Rain will cause rust on the inside of the cylinder.



#### TOWING

1. This unit should not be towed on any street, highway or public road without checking the existing federal, local or state vehicle requirements. Any licensing or modifications such as taillights, etc., needed to comply with the existing federal, local or state vehicle requirements is the sole responsibility of the purchaser.
2. Before towing, be certain the log splitter is correctly and securely attached to the towing vehicle, and the safety chains are in place. Leave slack in chains for turning allowance.
3. Do not allow anyone to sit or ride on your splitter. They can easily fall off and be seriously injured.

# ASSEMBLY INSTRUCTIONS

**IMPORTANT:** This unit has been shipped without gasoline or oil in the engine. After assembly, refer to separate engine manual for proper fuel and engine oil information.

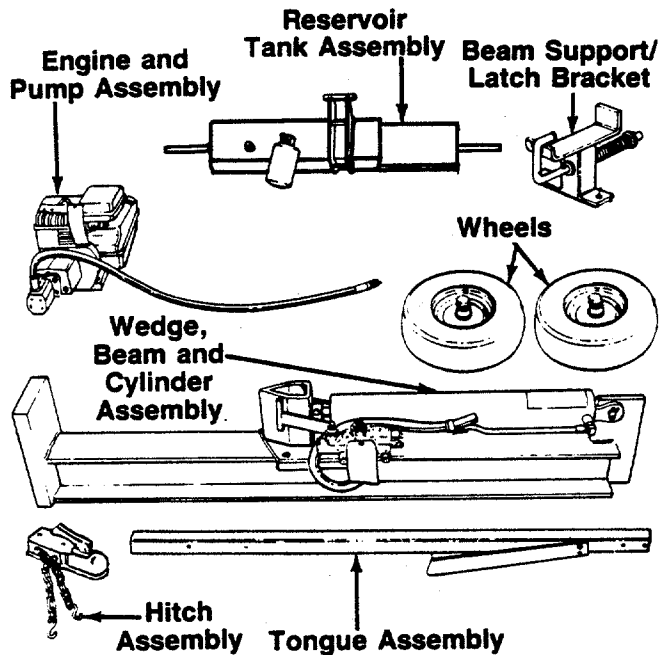

FIGURE 1.

## UNPACKING

Remove the log splitter parts from the carton by cutting the corners of the carton. Make certain all parts and literature have been removed from the carton before the carton is discarded.

All hardware for assembly of the log splitter has been placed in position on the various parts.

### ← Parts in Carton (See figure 1)

- Reservoir Tank Assembly
- Engine and Pump Assembly (Bolted to bottom of carton)
- Tongue Assembly
- Wedge, Beam and Cylinder Assembly
- Hitch Assembly
- Wheels

### Tools Required for Assembly

- (1) Rubber Mallet or Plastic Hammer
- (2) 9/16" Wrenches\*
- (2) 1/2" Wrenches\*
- (1) Adjustable Wrench
- (1) Screwdriver

\*Adjustable Wrenches may be used.

### Other Materials Required for Assembly:

- Engine Oil
- Unleaded Gasoline (regular grade gasoline is an acceptable substitute)
- Approximately 4 Gallons of Dexron II Automatic Transmission Fluid or 10W Non-Foaming Hydraulic Fluid

## INSTALLATION OF WHEELS

Attach the wheels to the reservoir tank assembly as follows. See figure 2.

1. Pry off the hub caps and dust covers which are attached to the wheels. Discard the dust covers (used for shipping only).
2. Remove one tapered roller bearing from inside each wheel. See inset.
3. Remove the cotter pin, hex slotted nut and flat washer from each axle. Place one wheel on each axle, with the valve stem facing outward.
4. Pack the tapered roller bearings with wheel bearing grease, and place one on each axle.
- ← 5. Place one flat washer removed in step 2 on each axle. Secure with hex slotted nut. Tighten slotted nut until snug, then back off approximately 1/3 turn or until one of the slots on the slotted nut lines up with the hole in the axle.
6. Check the assembly of the wheels. There should be no side to side play, and the wheel should spin freely.
7. Place hub caps in position on wheels and tap on with a rubber mallet or plastic hammer.

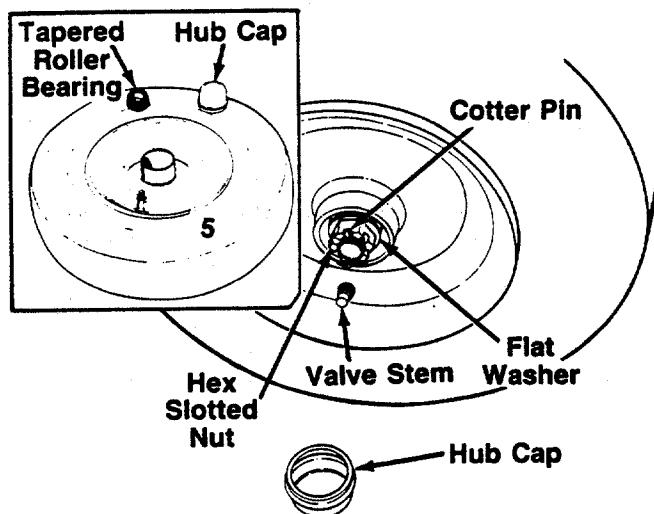

FIGURE 2.

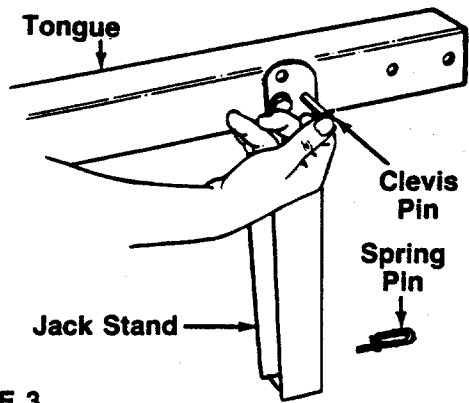

FIGURE 3.

**ATTACHING TONGUE TO RESERVOIR TANK**

1. The tongue is shipped with the jack stand already attached to the tongue. The jack stand is in the transport position. Remove the spring pin and clevis pin. Pivot the jack stand to the operating position (90°), and secure with the clevis pin and spring pin. See figure 3.

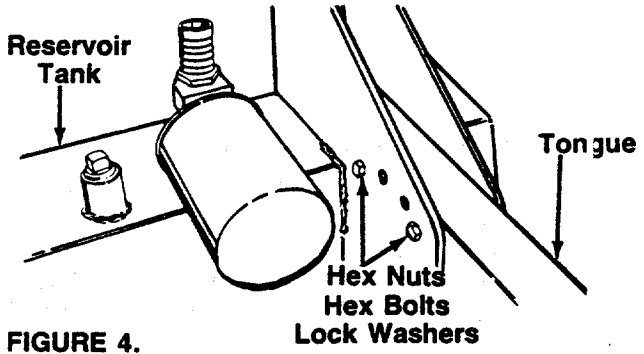

FIGURE 4.

2. Remove the two hex bolts, lock washers and hex nuts on the front of the reservoir tank. Two 9/16" wrenches are required. Place the tongue in position, and secure with hardware just removed. See figure 4.

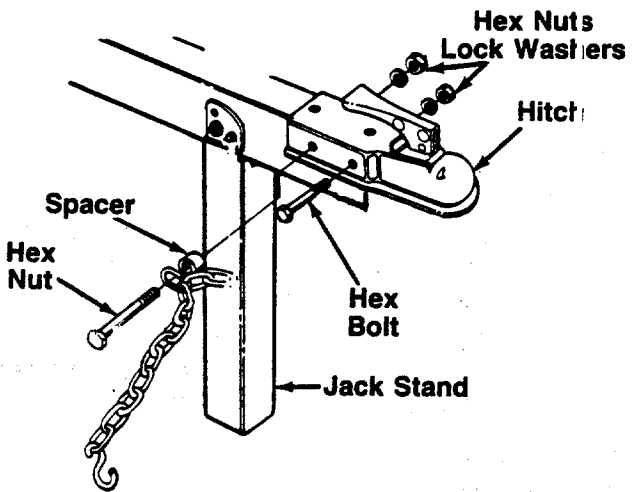

FIGURE 5.

**INSTALLING THE HITCH**

1. Using two 9/16" wrenches, remove the two long hex bolts, lock washers and hex nuts which are assembled through the sides of the hitch. Do not remove the chain and spacer from the one hex bolt.

2. Place the hitch in position on the end of the tongue as shown in figure 5. Secure with hardware just removed.



**ATTACHING THE WEDGE, BEAM AND CYLINDER ASSEMBLY**

1. Stand the wedge, beam and cylinder assembly upright.

2. Remove the cotter pin from the hinge pin, located on top of the reservoir tank assembly. Move the reservoir tank assembly in position against the beam.

3. Insert hinge pin just removed through welded brackets on beam and reservoir tank assembly. Secure with cotter pin, bending the ends of the pin in opposite directions.

**ATTACHING THE BEAM SUPPORT/LATCH BRACKET**

1. Remove the two hex bolts, lock washers and hex nuts from the tongue, using two 9/16" wrenches.

2. Place the beam support/latch bracket on the tongue as shown in figure 6. Secure with hex bolts, lock washers and hex nuts just removed. Tighten securely.

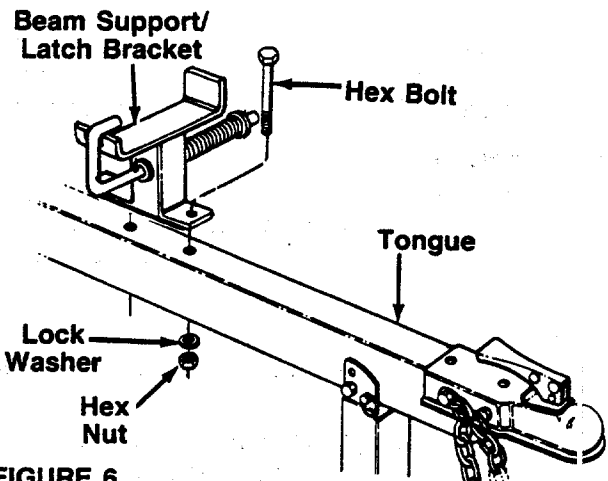

FIGURE 6.

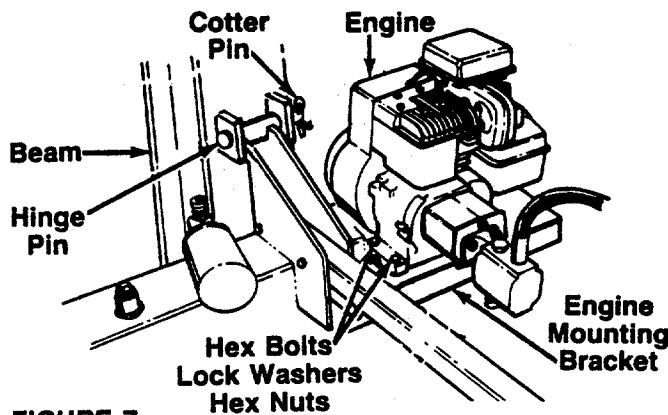

FIGURE 7.

### ATTACHING THE ENGINE AND PUMP ASSEMBLY

1. Using two  $\frac{1}{2}$ " wrenches, remove the four hex bolts, lock washers and hex nuts which secure the base of the engine to the bottom of the shipping carton.
2. Place the engine and pump assembly in position on the side of the reservoir tank assembly as shown in figure 7. Secure with hardware just removed. Tighten securely.

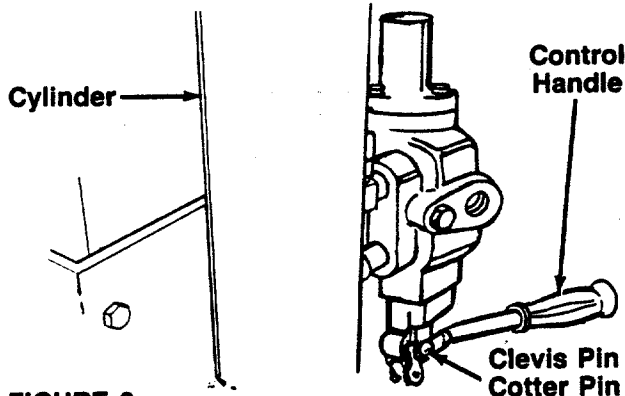

FIGURE 8.

### ATTACHING THE CONTROL HANDLE

1. The control handle is taped to the stripper half for shipping purposes only. Remove the tape.
2. The bottom of the control handle is already attached to the valve. Remove the cotter pin and clevis pin which are attached to the valve. Place the handle in position, and secure to the valve using the cotter pin and clevis pin. See figure 8.

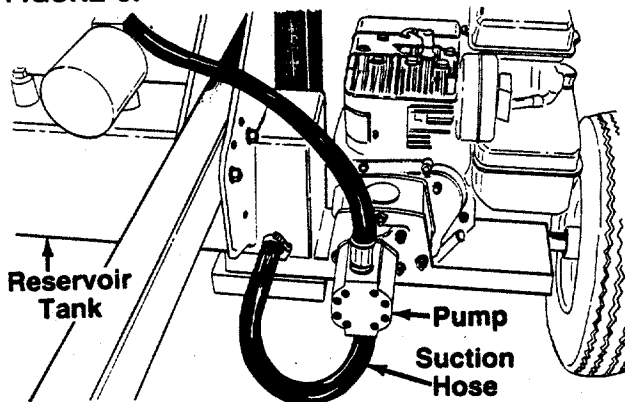

FIGURE 9.

### ATTACHING THE HOSES

#### Suction Hose

1. The suction hose is attached to the reservoir tank. See figure 9. Loosen the hose clamp on the free end of the hose using a screwdriver.
2. Attach the end of the hose to the fitting on the bottom of the pump. Place the hose clamp at the base of the fitting, and tighten securely.

#### Return Hose

1. The return hose is attached to the top of the valve. Loosen the hose clamp on the free end of the hose using a screwdriver.
2. Attach the end of the hose to the fitting on top of the filter head. See figure 10. Place the hose clamp at the base of the fitting, and tighten securely.

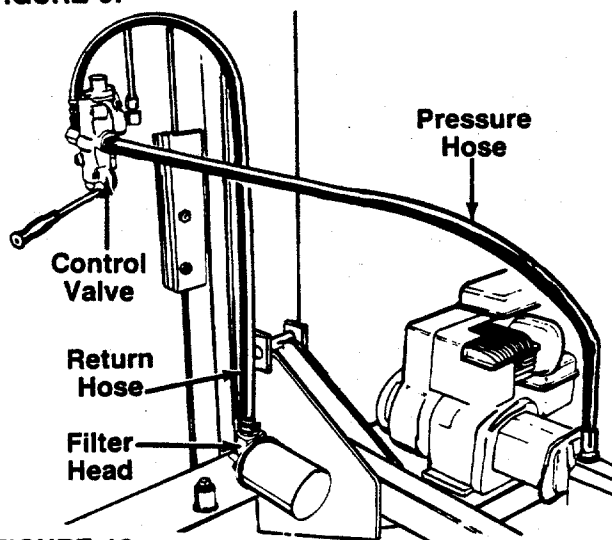

FIGURE 10.

#### Pressure Hose

The pressure hose is attached to the top of the pump. Route the hose as shown in figure 10. Secure the pressure hose to the bottom of the control valve, using an adjustable wrench.

### FINAL ASSEMBLY

1. Make certain all nuts, bolts and hose clamps are tightened securely.
2. Before operating the log splitter, make certain to follow "Initial Preparation" instructions.

# OPERATION

## INITIAL PREPARATION

1. Place the log splitter on a firm, level surface.
2. Service engine with gasoline and oil as instructed in the separate engine manual packed with your log splitter.
3. Lubricate the beam area where splitting wedge will slide with engine oil (DO NOT USE GREASE). Make certain to oil both front and back of the beam face.
4. Fill the reservoir tank as follows.
  - a. Remove reservoir vent plug. See figure 11. Using Dexron II automatic transmission fluid, or 10W non-foaming hydraulic fluid, fill reservoir to the top. Replace vent plug securely.
  - b. Disconnect the spark plug wire. Prime the pump by pulling the recoil starter, to turn the engine over, approximately 10 times. Reconnect the spark plug wire.

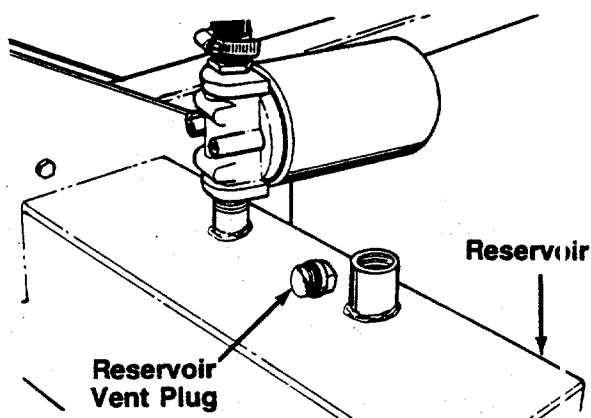

FIGURE 11.

- c. Start engine. Use the control handle to extend the wedge to the far extended position. Leave the wedge in this position (do not retract).
- d. Refill tank to within 1½" to 2" from the top of the tank. Total capacity of system is approximately 4 gallons.
- e. Now retract the wedge. Extend and retract the wedge fully 10 to 12 complete cycles to remove trapped air in the system (system is "self-bleeding").
- f. Refill the reservoir to within 1½" to 2" from the top of the tank. Much of the original fluid has been drawn into the cylinder and hoses. Make certain to refill the reservoir, to prevent extreme damage to the hydraulic pump. Failure to refill the tank will void your warranty.

**NOTE:** Some fluid may overflow from the vent plug as the system builds heat and the fluid expands and seeks its own level.



**WARNING:** Do not operate the log splitter without the proper amount of transmission fluid in the reservoir tank.

## BEFORE STARTING

Before each use, check the following:

1. Place log splitter on a firm, level surface. For vertical operation, pull the locking rod out and pivot it down to release the beam. Place the beam in the vertical position.
2. Remove the vent plug and check the fluid level. Fluid level should be 1½" to 2" from the top of the tank.

**IMPORTANT:** Reservoir tank must be full as instructed. Low fluid level will damage the pump and void your warranty.

3. Lubricate the beam area where splitting wedge will slide with engine oil (DO NOT USE GREASE). Make certain to oil both front and back of the beam face.
4. Fill gasoline tank as instructed in separate engine manual.
5. Attach spark plug wire to spark plug.

## TO START ENGINE

1. Place throttle control lever on the engine in FAST position. See figure 12.
2. Place choke lever in CHOKE position (a warm engine may not require choking).
3. Grasp starter handle and pull rope out slowly until engine reaches start of compression cycle (rope will pull slightly harder at this point). Let the rope rewind slowly.



**WARNING:** When restarting a warm engine, keep away from muffler and other heated surfaces on the engine.

4. Pull rope with a rapid, continuous, full arm stroke. Keep a firm grip on the starter handle. Let the rope rewind slowly. Do not let starter handle snap back against starter.
5. Repeat preceding instructions 3 and 4 until engine fires. When engine starts, move choke lever halfway between CHOKE and RUN.
6. Move throttle control lever to IDLE position for a few minutes warm-up. Gradually move choke lever to RUN position as engine warms up.



**NOTE:** In order to idle smoothly, a new engine may require 3 to 5 minutes running above slow idle speed. Idle speed has been adjusted to be correct after this break-in period.

- If weather is cold, run wedge up and down beam 6 to 8 times to circulate the hydraulic fluid, which will warm and thin the fluid.

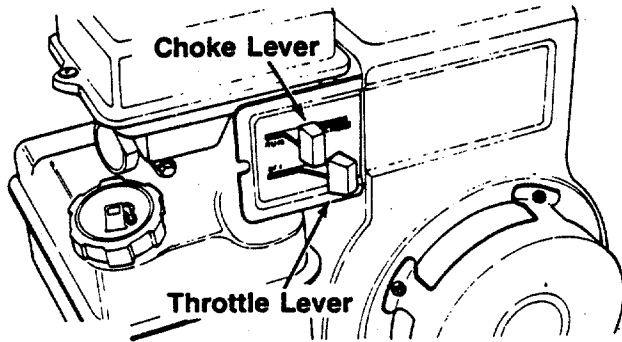

FIGURE 12.

### TO STOP ENGINE

- Move throttle control lever to OFF position.
- Disconnect spark plug wire from spark plug to prevent accidental starting while equipment is unattended.

### USING THE LOG SPLITTER

Use the log splitter only on a level, hard surface. Never stand next to the splitting wedge when operating the log splitter. Always stand behind the reservoir tank. See figures 13 and 14. Never attempt to cut a log in half sideways. Always split the log lengthwise. Maximum length of log to be split is 24".



**WARNING:** Always use the log splitter in the vertical position only when splitting heavy logs.

The control handle has three positions:

**FORWARD**—Push the control handle down for vertical operation, push it forward for horizontal operation—Splitting wedge moves toward the end plate. Control handle will return to neutral position as soon as handle is released.

**NEUTRAL** (Middle position)—Splitting wedge stops in place.

**REVERSE**—Push the control handle upward for vertical operation, push it toward the rear for horizontal operation—Splitting wedge returns. The control handle will lock in the reverse position, and will return to neutral automatically when the reverse stroke is complete.

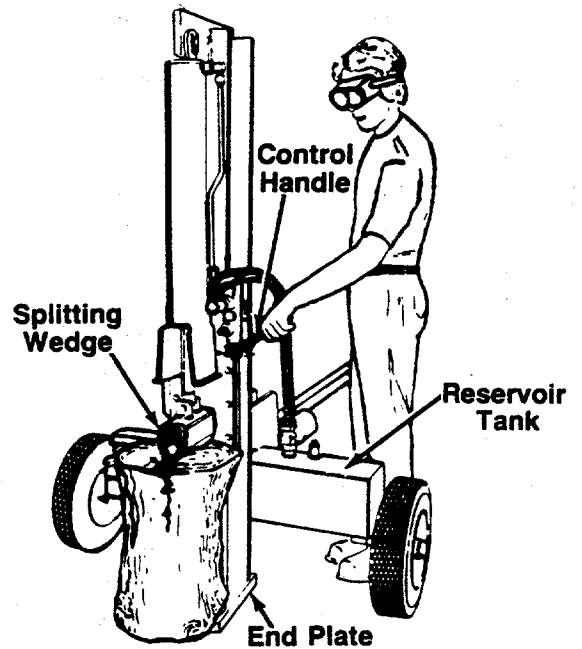

FIGURE 13.—Vertical Position

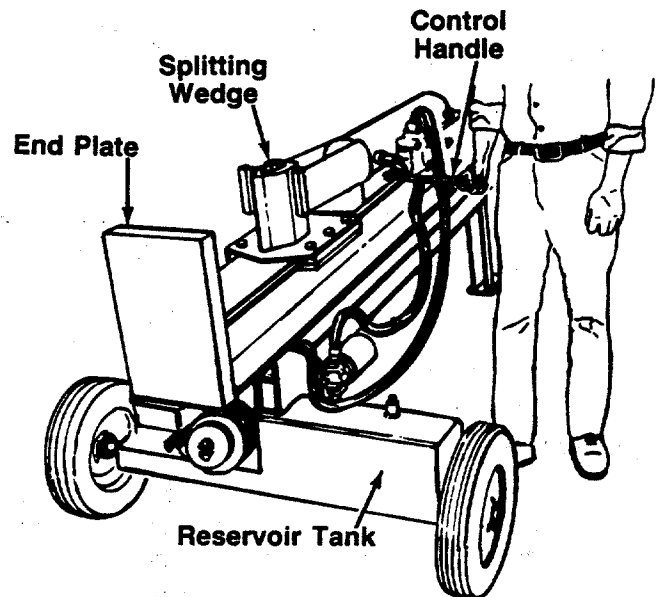

FIGURE 14.—Horizontal Position

### TO OPERATE LOG SPLITTER:

- Set throttle at maximum speed.
- Place the log upright, on top of end plate for vertical operation, and on top of beam for horizontal operation.
- Push the control handle in forward position until the splitting wedge just contacts the log. Release the control handle.
- Step behind the reservoir tank** (see figures 13 or 14) and push the control handle in forward position until the log is split.
- Move the control handle to reverse position to return the splitting wedge.



**WARNING:** If the fluid becomes excessively hot at any time during operation, stop the unit and allow the fluid to cool down. Maximum performance will not be obtained from your log splitter if the fluid is too hot. Use extreme caution as contacting hot fluid could result in serious personal injury.

## TO TRANSPORT LOG SPLITTER

1. Lower the beam to its horizontal position. Make certain the beam is latched securely with the locking rod.
2. Remove the quick release pin which secures the jack stand. Pivot it up against the tongue, and secure with the quick release pin.
3. Attach the hitch to a towing vehicle, making certain to latch securely. Attach the safety chains to the towing vehicle.

## ADJUSTMENT



**WARNING:** Always stop the engine and disconnect the spark plug wire before performing any adjustments.

### SPLITTING WEDGE

As normal wear occurs, periodically adjust the bolts on the slide plate (beneath the splitting wedge) as follows to eliminate the excess space between the wedge plate and the beam. See figure 15.

1. Loosen the three hex bolts on top of the slide plate (beneath the splitting wedge).
2. Back the two adjustment bolts on the side of the slide plate out **slowly** until the wedge assembly will slide on the beam. Tighten the lock nuts securely against the base of the slide plate to hold the bolts in this position.
3. Retighten the three hex bolts on top of the slide plate.

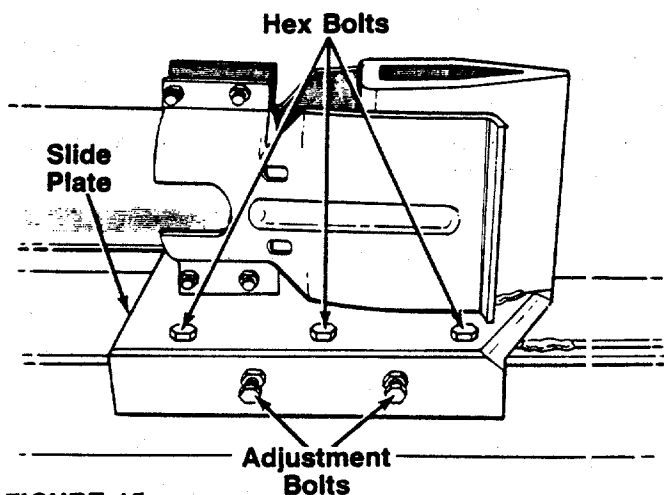

FIGURE 15.

## CARBURETOR ADJUSTMENT



**WARNING:** If any adjustments are made to the engine while the engine is running (e.g. carburetor), keep clear of all moving parts. Be careful of heated surfaces and muffler.

Minor carburetor adjustment may be required to compensate for differences in fuel, temperature, altitude or load. Improper adjustment will cause stalling when splitter is under load, hard starting and higher fuel consumption.

Refer to the separate engine manual packed with your log splitter for carburetor adjustment information.

**NOTE:** A dirty air cleaner will cause engine to run rough. Be certain air cleaner is clean and attached to the carburetor before adjusting carburetor. Do not make unnecessary adjustments. Factory settings are satisfactory for most applications and conditions.

## MAINTENANCE



**WARNING:** Always stop the engine and disconnect the spark plug wire before performing any maintenance or repairs.

### RESERVOIR FLUID

Check the hydraulic fluid level in the log splitter reservoir tank before each use. Fluid level should be 1½" to 2" from the top of the tank.

Change the hydraulic fluid in the reservoir every 100 hours of operation. Disconnect the suction hose from the bottom of the reservoir tank, and drain the fluid into a suitable container. Refill using only Dexron II automatic transmission fluid or 10W non-foaming hydraulic fluid, as instructed in the "Initial Preparation" section of this manual, page 8. Also, make certain to change the hydraulic filter.

**NOTE:** Drain the fluid and flush the reservoir tank and hoses with kerosene whenever any repair work is performed on the tank, hydraulic pump or valve. Contaminants in the fluid will damage the hydraulic components. (Should be performed by an authorized service dealer.)



**WARNING:** Use extreme caution when working with kerosene, as it is an extremely flammable fluid.

### HYDRAULIC FILTER

Change the hydraulic filter every 50 hours of operation. Use only a 10 micron hydraulic filter. Order part number 723-0405.

## BEAM AND SPLITTING WEDGE

Lubricate both sides of the beam where it contacts the splitting wedge with engine oil before each use to obtain years of service. However, normal wear will occur. The wedge plate on the log splitter is designed so the gibs on the side of the wedge plate can be easily removed and rotated and/or turned over for even wear. Make certain to readjust the adjustment bolts so wedge moves freely, but no excess space exists between the wedge plate and beam.

## HOSE CLAMPS

Check the hose clamps on the suction hose (attached to bottom of the pump) for proper tightness before each use. Check the hose clamps on the return hose at least once a season.

## ENGINE

Refer to the separate engine manual for all engine maintenance instructions.

Maintain engine oil as instructed in the separate engine manual packed with your unit. Read and follow instructions carefully.

Service air cleaner every 25 hours under normal conditions. Clean every few hours under extremely dusty conditions. Poor engine performance and flooding usually indicates that the air cleaner should be serviced. To service the air cleaner refer to the separate engine manual packed with your unit.

The spark plug should be cleaned and the gap reset once a season. Spark plug replacement is recommended at the start of each season; check engine manual for correct plug type and gap specification.

Clean the engine regularly with a cloth or brush. Keep the cooling system (blower housing area) clean to permit proper air circulation which is essential to engine performance and life. Be certain to remove all dirt and combustible debris from muffler area.

## FLEXIBLE PUMP COUPLER

The flexible pump coupler is a nylon "spider" insert, located between the pump and engine shaft. The alignment is very critical. Over a period of time, the coupler will harden and deteriorate. For a replacement flexible pump coupler, order part number 717-0891.

**IMPORTANT: Never hit the pump shaft in any manner, as any blow will cause permanent damage to the pump.**

When replacing the flexible pump coupling, proceed as follows.

1. Place the coupling half onto the engine shaft. Make certain there is clearance between the coupling half and the engine. Tighten the set screw.
2. Mount the pump onto the coupling support bracket. Tighten securely.

3. Carefully slide coupling half onto pump shaft (make certain set screw is loose). Slide the key into place on the shaft.
4. Install the nylon "spider" insert into coupling half on the engine shaft.
5. Place the coupling shield in position on the hex bolts. Rotate the keyway on the pump shaft so it is toward the bottom.
6. Attach the coupling support bracket to the hex bolts, carefully sliding the coupling half over the "spider" insert. Secure coupling shield and coupling support bracket with lock washers and hex nuts. Tighten securely.
7. Adjust the two coupling halves (steel) so there is between .010" and .060" clearance between the two halves (at least the thickness of a matchbook cover, up to 1/16" maximum). See figure 16. Tighten the set screw in the coupling half on the pump shaft.

**NOTE:** Make certain proper clearance is obtained before tightening set screw.

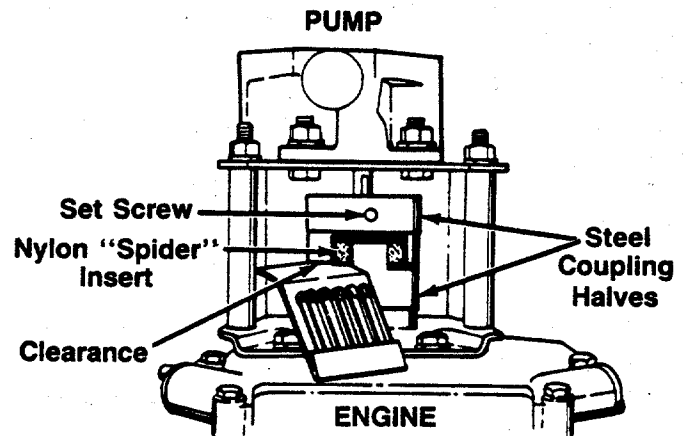

FIGURE 16.—Bottom View

## TIRE PRESSURE

Check sidewall of tire for manufacturer's recommended maximum tire pressure. If this information does not appear on your tire, maximum tire pressure under any circumstances is 30 p.s.i. Equal pressure should be maintained on both tires.

## INSTALLATION OF TIRE TO RIM



**WARNING:** The following procedure must be followed when removing or installing a tire to the rim.

1. Be certain rim is clean and free of rust.
2. Lubricate both the tire and rim generously.

3. Never inflate to over 30 p.s.i. to seat beads. Excessive pressure when seating beads may cause tire/rim assembly to burst with force sufficient to cause serious injury.

## OFF-SEASON STORAGE

To avoid engine problems, the fuel system should be emptied before storage of 30 days or longer. Follow these instructions.

1. Drain the fuel tank. Start the engine, and let it run until the fuel lines and carburetor are empty.



**WARNING:** Do not drain fuel while smoking, or if near an open fire.

2. Drain all the oil from the crankcase (this should be done after the engine has been operated and is still warm) and refill the crankcase with fresh oil.
3. Protect the inside of the engine for storage as follows.

Remove spark plug, pour approximately  $\frac{1}{2}$  ounce (approximately one tablespoon) of engine oil into cylinder and crank slowly to distribute oil. Replace spark plug.

4. Clean the engine and the entire log splitter thoroughly.
5. Wipe unit with an oiled rag to prevent rust, especially wedge and beam.

**NOTE:** When storing any type of power equipment in an unventilated or metal storage shed, care should be taken to rustproof the equipment by coating with a light oil or silicone.

6. The tongue can be removed and reattached in an upright position as shown in figure 17 to take less space when storing.
7. Store unit in a clean, dry area.

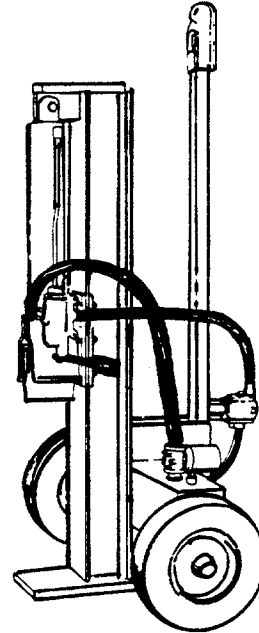

FIGURE 17.

# TROUBLE SHOOTING GUIDE

Trouble	Possible Cause(s)	Corrective Action
Engine fails to start	<ol style="list-style-type: none"> <li>1. Fuel tank empty, or stale fuel.</li> <li>2. Blocked fuel line.</li> <li>3. Spark plug wire disconnected.</li> <li>4. Faulty spark plug.</li> </ol>	<ol style="list-style-type: none"> <li>1. Fill tank with clean, fresh gasoline.</li> <li>2. Clean fuel line.</li> <li>3. Connect wire to spark plug.</li> <li>4. Clean, adjust gap or replace.</li> </ol>
Engine runs erratic	<ol style="list-style-type: none"> <li>1. Unit running on CHOKE.</li> <li>2. Spark plug wire loose.</li> <li>3. Blocked fuel line or stale fuel.</li> <li>4. Water or dirt in fuel system.</li> <li>5. Dirty air cleaner.</li> <li>6. Carburetor out of adjustment.</li> </ol>	<ol style="list-style-type: none"> <li>1. Move choke lever to OFF position.</li> <li>2. Connect and tighten spark plug wire.</li> <li>3. Clean fuel line; fill tank with clean fresh gasoline.</li> <li>4. Drain fuel tank. Refill with fresh fuel.</li> <li>5. Clean air cleaner as instructed in separate engine manual.</li> <li>6. Adjust carburetor (see Carburetor Adjustment in separate engine manual).</li> </ol>
Engine overheats	<ol style="list-style-type: none"> <li>1. Engine oil level low.</li> <li>2. Air flow restricted.</li> <li>3. Carburetor not adjusted properly.</li> </ol>	<ol style="list-style-type: none"> <li>1. Fill crankcase with proper oil.</li> <li>2. Remove blower housing and clean as instructed in separate engine manual.</li> <li>3. Adjust carburetor (see Carburetor Adjustment in separate engine manual).</li> </ol>
Will not split logs	Reservoir fluid level low.	Check and fill reservoir tank as instructed in Operation section of this manual.
Leaking cylinder	<ol style="list-style-type: none"> <li>1. Broken seals.</li> <li>2. Scored cylinder.</li> </ol>	<ol style="list-style-type: none"> <li>1. Replace seals.*</li> <li>2. Replace cylinder.*</li> </ol>

**NOTE:** For repairs beyond the minor adjustments listed above, please contact your nearest authorized service dealer.

\*Should be performed by an authorized service dealer only.

# HOW YOUR LOG SPLITTER OPERATES

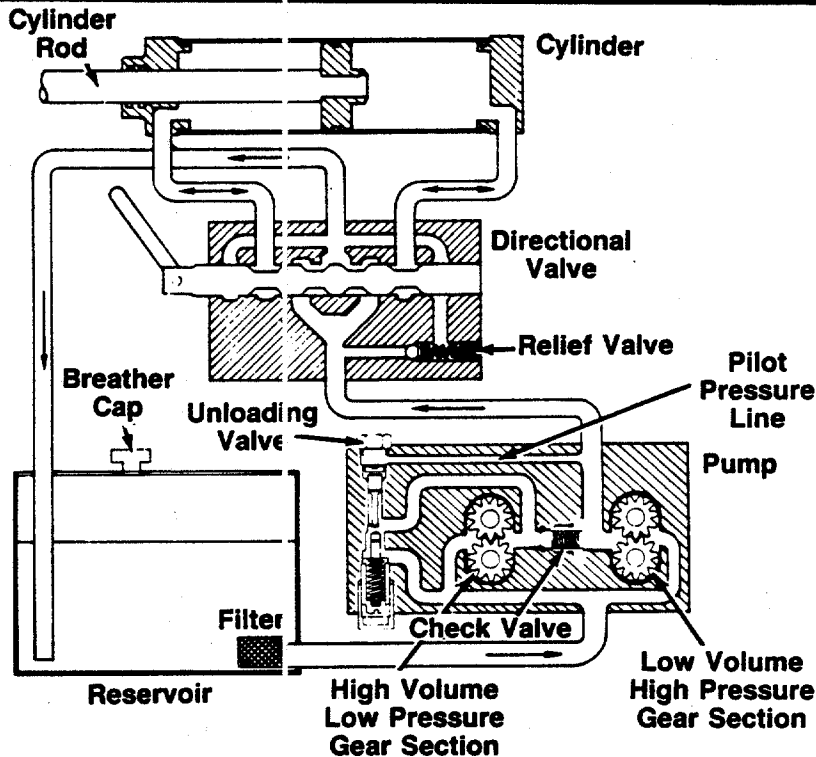

## THE PUMP

A two-stage log splitter pump has one large and one small gear section, using common inlet and outlet ports. Below a preset pressure (called unloading pressure) a check valve between the two gear sections allows both flows to combine. Together, the two gear sections create a large volume flow which produces rapid cylinder movement under low load conditions.

Above unloading pressure, a pilot pressure line (which simulates actual pressure at the cylinder) activates the unloading valve, which causes the flow to bypass the large gear section and return to the pump inlet area. The small gear section is now operating alone, and will generate the higher pressure necessary for the actual log splitting operation.

The original factory setting for the unloading valve is designed to provide maximum flow while remaining below engine stalling load. **Note: Splitting capability is not affected by the setting of the unloading valve. Do not attempt to adjust or reset it without a pressure gauge (should be performed by an authorized service dealer only).**

## THE DIRECTIONAL VALVE AND CYLINDER

From the pump, oil flows to a four way, three position directional valve. At the neutral position this valve directs the flow back to the oil reservoir, bypassing the cylinder. When the directional valve is directing the flow to the back of the cylinder, the cylinder rod extends quickly until it meets significant resistance. Upon reaching unloading pressure, movement of the shaft

will slow but will continue forward. If the pressure reaches a preset maximum (called relief valve pressure) the relief valve, located within the directional valve, will allow the flow to bypass the cylinder and return to the reservoir. This can happen when the cylinder rod meets excessive resistance, or when it reaches the end of its stroke and can move no farther.

**Note: Never operate at relief valve pressure for more than a few seconds.**

When the directional valve is directing the flow to the front of the cylinder, the rod will retract quickly since it is encountering no resistance. The relief valve will momentarily bypass the flow at the end of the return stroke but the directional valve should then automatically return to the neutral position, directing the flow directly into the reservoir. This serves to protect the pump from possible damage due to prolonged operation at relief valve pressure.

Because of the potential for system damage, the relief valve is carefully and precisely preset by the manufacturer.

**Note: The user should not attempt to adjust or change the setting of the relief valve.**

## OPERATIONAL PROBLEMS

If you have trouble with your log splitter, please refer to the Hydraulic Trouble Shooting Guide on page 15.

**Note: Readjustment of valves or disassembly of pump should be performed by an authorized service dealer only.**

# HYDRAULIC TROUBLE SHOOTING GUIDE

Problem	Probable Cause(s)	Corrective Action
Cylinder rod will not move	A Broken driveshaft B Loose shaft coupling C Gear sections damaged D Damaged relief valve E Hydraulic lines blocked F Too little oil to pump G Damaged directional valve H Blocked directional valve	A Return pump for authorized repair B Correct engine/pump alignment as necessary C Return pump for authorized repair D Return directional valve for authorized repair E Flush and clean hydraulic system F Add oil to reservoir G Return directional valve for authorized repair H Flush and clean hydraulic system; return directional valve for authorized repair
Slow cylinder shaft speed while extending and retracting	A Gear sections damaged B Excessive pump inlet vacuum  C Slow engine speed D Damaged relief valve E Too little oil to pump F Air in oil  G Directional valve leaking internally H Internally damaged cylinder	A Return pump for authorized repair B Make certain pump inlet hoses are clear and unblocked—use short, large diameter inlet hoses C Return engine for authorized repair D Return directional valve for authorized repair E Add oil to reservoir F Add oil, clean reservoir, make certain oil return tube is below oil level G Return directional valve for authorized repair H Return cylinder for authorized repair
Engine runs but wood will not split, or wood splits too slowly	A Small gear section damaged B Pump check valve leaking C Excessive pump inlet vacuum  D Low relief valve setting E Too little oil to pump F Air in oil  G Directional valve leaking internally H Overloaded cylinder I Internally damaged cylinder	A Return pump for authorized repair B Return pump for authorized repair C Make certain pump inlet hoses are clear and unblocked; use short, large diameter inlet hoses D Adjust valve while using pressure gauge* E Add oil to reservoir F Add oil, clean reservoir, make certain oil return tube is below oil level G Return directional valve for authorized repair H Do not attempt to split wood against the grain I Return cylinder for authorized repair
Engine stalls during splitting	A Low horsepower/weak engine B High relief valve setting C High unloading valve setting D Overloaded cylinder	A Return engine for authorized repair B Adjust valve while using pressure gauge* C Adjust valve while using pressure gauge* D Do not attempt to split wood against the grain
Engine will not turn or stalls under low load conditions	A Engine/pump misalignment B Frozen or seized pump C Low horsepower/weak engine D Hydraulic lines blocked E Blocked directional valve	A Correct alignment as necessary B Return pump for authorized repair C Return engine for authorized repair D Flush and clean hydraulic system E Flush and clean hydraulic system; return directional valve for authorized repair
Leaking pump shaft seal	A Broken driveshaft B Engine/pump misalignment C Gear sections damaged D Poorly positioned shaft seal E Plugged oil breather	A Return pump for authorized repair B Correct alignment as necessary C Return pump for authorized repair D Return pump for authorized repair E Make certain reservoir is properly vented

\*Should be performed by an authorized service dealer only.

# Model 521



Specifications subject to change without notice or obligation.

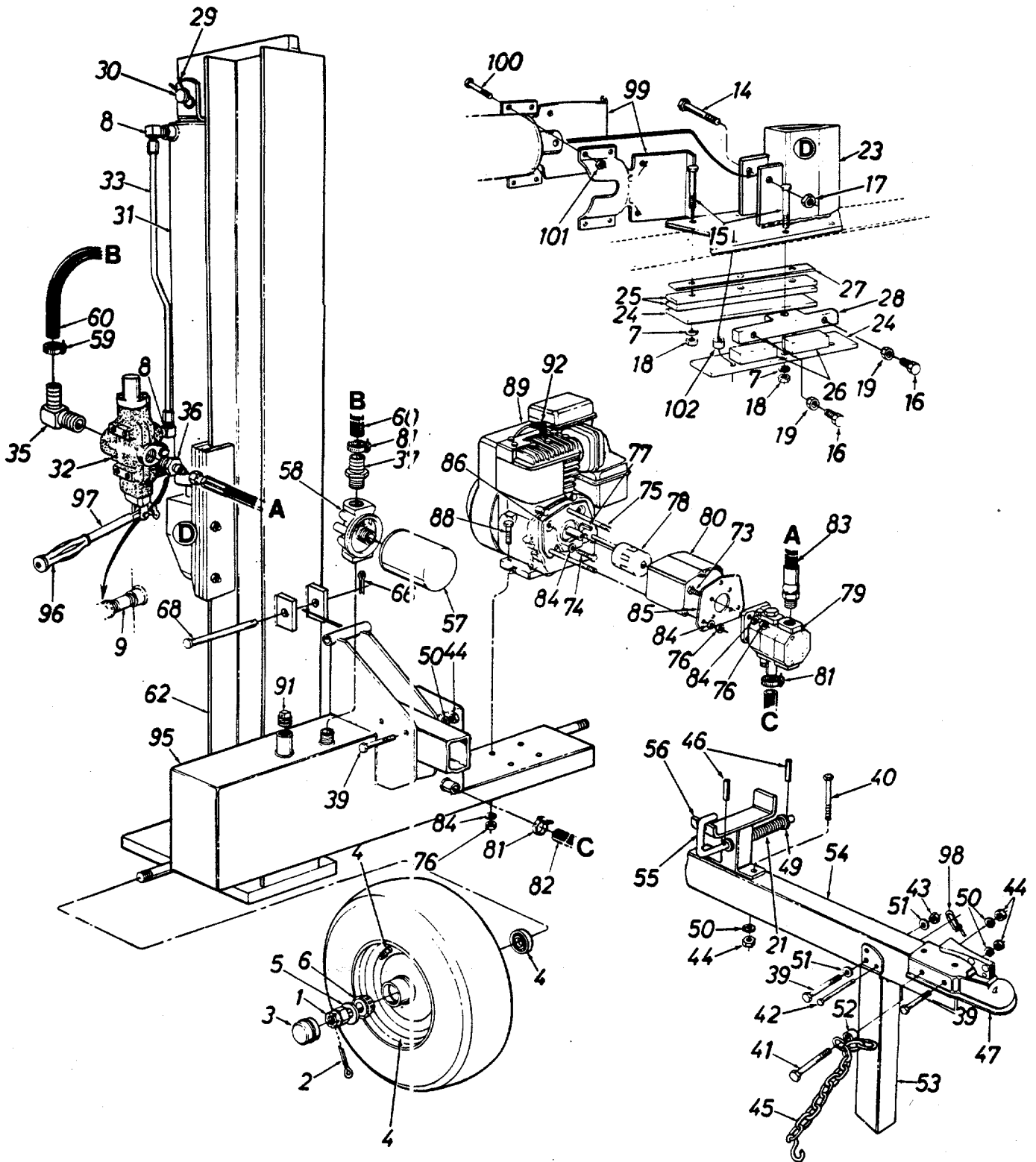



# Model 521

## PARTS LIST FOR MODEL 521 LOG SPLITTER

REF. NO.	PART NO.	CODE	DESCRIPTION	REF. NO.	PART NO.	CODE	DESCRIPTION
1	712-0359		Slotted Nut 3/4-16 Thd.	46	715-0116		Roll Pin
2	714-0162		Cotter pin 5/32" Dia.	47	727-0311		Hitch Coupler
3	734-0873		Hub Cap	49	736-0116		FI-Wash. .635" I.D.* x .93" O.D.
4	734-1016		Wheel Ass'y. Comp.	50	736-0169		L-Wash. 3/8" I.D.*
	734-0872		Tire Only	51	736-0185		FI-Wash. .406" I.D. x .75" O.D.
	734-1017		Rim Only	52	750-0507		Spacer .27" Lg.
	721-0168		Bearing Seal Only	53	781-0162	638	Jack Stand
	734-0255		Air Valve Only	54	781-0399		Tongue Tube
5	736-0351		FI-Wash. .76" I.D. x 1.5" O.D.	55	781-0370		Locking Rod
6	741-0107		Roller Bearing	56	781-0398		Beam Support Ass'y.
7	736-0921		L-Wash. 1/2" I.D.*	57	723-0405		Filter Element
8	737-0192		90° Solid Male Adaptor	58	723-0406		Filter Head
9	737-0238		Pipe Nipple 1/2 NPT	59	726-0146		Adj. Hose Clamp
14	710-1010		Hex Bolt 1/2-20 x 3" Lg. (Grade 8)	60	727-0443		Return Hose 3/4" I.D. x 44" Lg.
15	710-1018		Hex Bolt 1/2-20 x 2.75" Lg. (Grade 8)	62	781-0404		Vertical Beam Ass'y.
16	710-1032		Hex Bolt 3/8-24 x 1.5" Lg.	66	714-0470		Cotter Pin 1/8" Dia.
17	712-0239		Hex L-Nut 1/2-20 Thd.	68	738-0805		Hinge Pin 1/2 x 4.8" Lg.
18	712-0333		Hex Nut 1/2-20 Thd.	73	710-0117		Hex Bolt 5/16-24 x 1" Lg.
19	712-3001		Hex Jam Nut 3/8-24 Thd. (Grade 5)	74	710-0237		Hex Bolt 5/16-24 x .62" Lg.
21	732-0583		Comp. Spring 4" Lg.	75	710-0968		Hex Bolt 5/16-24 x 5" Lg.
23	781-0323B		Wedge Ass'y.	76	712-0123		Hex Nut 5/16-24 Thd.
24	781-0345A		Pusher Back Plate	77	714-0122		Sq.-Key 3/16" x .75"
25	781-0350A		Fixed Side Gib	78	717-0891		Flexible Coupling
26	781-0351		Adjustable Gib	79	717-0887A		Two Volume Pump
27	781-0352A		Adjustable Gib Shim	80	719-0281		Coupling Shield
28	781-0356		Floating Gib Plate	81	726-0132	N	Hose Clamp 5/8"
29	714-0203		External Cotter Pin	82	727-0448		Suction Hose 3/4" I.D. x 17" Lg.
30	715-0206		Cylinder Mounting Pin	83	727-0324		High Pressure Hydraulic Hose 62"
31	717-0885B	629	Hydraulic Cylinder	84	736-0119		L-Wash. 5/16" I.D.*
32	717-0899		Control Valve	85	781-0097		Rear Coupling Support Brkt.
33	727-0323		Metal Pressure Tube	86	781-0098		Front Coupling Support Brkt.
35	737-0153		Return Elbow	88	710-0409		Hex Bolt 5/16-24 x 1.75" Lg.
36	737-0279		Adapter	89	—		Engine
37	737-0235		3/4" Hose Barb.	91	737-0236		L-Vent Pipe Plug
39	710-0521		Hex Bolt 3/8-16 x 3" Lg. (Grade 8)	92	735-0639		Spark Plug Boot
40	710-0411		Hex Bolt 3/8-16 x 4" Lg.	95	781-0501	638/N	Tank Ass'y.
41	710-3130		Hex Bolt 3/8-16 x 3.25" Lg. (Grade 8)	96	720-0235		Grip
42	711-0813		Clevis Pin 5/16 x 2.5" Lg.	97	747-0583		Control Handle
43	712-0375		Hex L-Nut 3/8-16 Thd.	98	732-0194		Spring Pin
44	712-0798		Hex Nut 3/8-16 Thd.	99	781-0168A		Stripper Plate
45	713-0338		Chain—Tow Hitch	100	710-3144		Hex Bolt 3/8-16 x 2.0" Lg. (Gr. 5)
				101	712-0430		Hex L-Nut 3/8-16 Thd.
				102	750-0743		Spacer 1/2" I.D. x .68" Lg.

\*For faster service obtain standard nuts, bolts and washers locally. If these items cannot be obtained locally, order by part number and size as shown on parts list.

629-Silver Flake; 638-Red

CODE: N notates a new part (not previously existing). A three digit number is the color code. Specify color code as shown above if color or finish is important when ordering parts. [i.e., 638 for Red Finish].

NOTE: The engine is not under warranty by the log splitter manufacturer... If repairs or service is needed on the engine, please contact your nearest authorized engine service outlet. Check the "Yellow Pages" of your telephone book under "Engines—Gasoline."



# **ONE YEAR LIMITED WARRANTY**

For one year from the date of original retail purchase, MTD PRODUCTS INC will either repair or replace, at its option, free of charge, F.O.B. factory or authorized service firm, any part or parts found to be defective in material or workmanship. Transportation charges for the movement of any power equipment unit or attachment are the responsibility of the purchaser. Transportation charges for any parts submitted for replacement under this warranty must be paid by the purchaser unless such return is requested by MTD PRODUCTS INC. In addition, MTD PRODUCTS INC will not be responsible for any incidental, special or consequential damages.

Warranty on units used commercially is limited to ninety (90) days.

This warranty will not apply to any part which has become inoperative due to normal wear, misuse, excessive use, accident, neglect, improper maintenance, alterations, modifications, or if the unit has not been operated and maintained in accordance with the instructions furnished. This warranty does not apply to the engine or component parts thereof (refer to the engine manufacturer's warranty).

Warranty service is available through your local authorized service dealer or distributor. If you do not know the dealer or distributor in your area, please write to the Customer Service Department of MTD PRODUCTS INC.

The return of a complete unit will not be accepted by the factory unless prior written permission has been extended by MTD PRODUCTS INC.

This warranty gives you specific legal rights. You may also have other rights which vary from state to state.