

\$1.00

OWNER'S GUIDE

OUTDOOR POWER EQUIPMENT
for all seasons

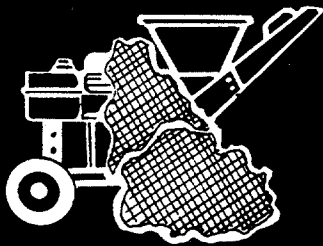
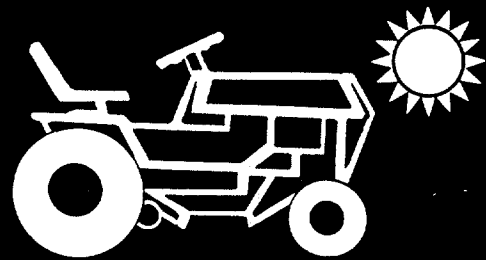

LEAF BLOWERS

Model Numbers

248-692-000

248-693-000

248-694-000

24695-8

1640 CFM

IMPORTANT:

Read Safety Rules and
Instructions Carefully

Thank you for purchasing
an American-built product.

INDEX

Safe Operation Practices	3	Maintenance and Lubrication.....	6
Assembly Instructions	4	Off-Season Storage.....	6
Operation.....	5	Trouble Shooting Chart	
Adjustments.....	6	Illustrated Parts	8,9



Instructions given with this symbol are for personal safety. Be sure you follow them.



This unit is equipped with an internal combustion engine and should not be used on or near any unimproved forest-covered, brush-covered or grass-covered land unless the engine's exhaust system is equipped with a spark arrester meeting applicable local or state laws (if any). If a spark arrester is used, it should be maintained in effective working order by the operator.

In the State of California the above is required by law (Section 4442 of the California Public Resources Code). Other states may have similar laws. Federal laws apply on federal lands. A spark arrester for the muffler is available through your nearest engine authorized service center.

IMPORTANT

It is suggested that this manual be read in its entirety before attempting to assemble or operate. Keep this manual in a safe place for future reference and for ordering replacement parts.

This unit is shipped **WITHOUT GASOLINE** or **OIL**. After assembly, see separate engine manual for proper fuel and engine oil recommendations.

SAFE OPERATION PRACTICES FOR LEAF BLOWERS

1. Read this operating and service instructing manual carefully. Be thoroughly familiar with the controls and proper use of the power leaf blower.
2. Never allow children to operate this power leaf blower.
3. Keep the area of operation clear of all persons, particularly small children and pets.
4. Check fuel before starting engine. Do Not fill fuel tank indoors, when engine is running, or while engine is hot. Wipe off any spilled fuel before starting engine.
5. Do Not change engine governor settings.
Do Not put hands near rotating parts for any reason.
7. If the power leaf blower should start to vibrate abnormally, stop the engine and check immediately for the cause. Vibration is generally a warning of trouble.
8. Before cleaning, repairing or inspecting make certain all moving parts have come to a complete stop. Disconnect spark plug wire and keep wire away from plug to prevent accidental starting. Also keep throttle control lever in the stop position.
9. If the power leaf blower should become blocked with debris at any point, shut engine off and wait until the impeller comes to a complete stop before attempting to remove the obstruction. Disconnect spark plug wire to prevent accidental starting.
10. Check all bolts for tightness at frequent periods.
11. Never store this power leaf blower with fuel in the tank. Allow engine to cool before storing in any enclosure.
12. Keep equipment free of debris when not in use.
13. Never operate this leaf blower unless impeller guard and guard assembly are properly affixed in their place.
14. Never change inlet nozzle or auxiliary hose attachment when engine is running.
15. The manufacturer recommends that the operator wear safety glasses or some other suitable eye protection when operating this machine.
16. Exercise caution whenever operating leaf blower. Do Not allow exhaust to be pointed in the direction of persons.
17. No one should operate this unit while intoxicated or while taking medication that impairs the senses or reactions.

ASSEMBLY INSTRUCTIONS

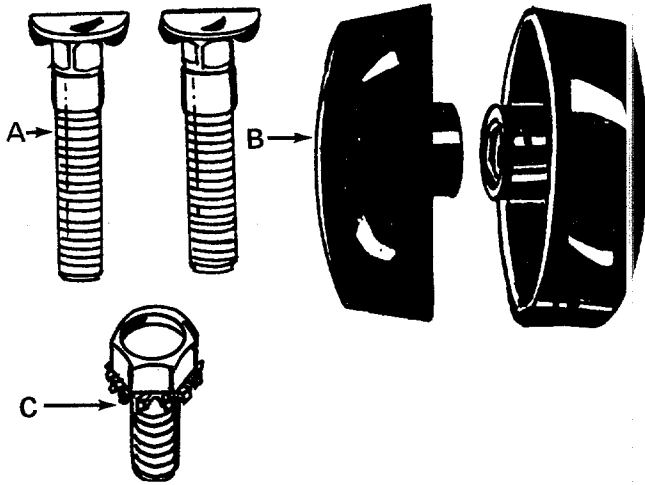

FIGURE 1.



NOTE

Vacuum hose attachment 247-204-000 comes with model 694. It is optional equipment on all other models.

CONTENTS OF HARDWARE PACK: (See Figure 1)

- A (2) Carriage Bolts
- B (2) Hand Knobs
- C (1) Hex Sems Bolt

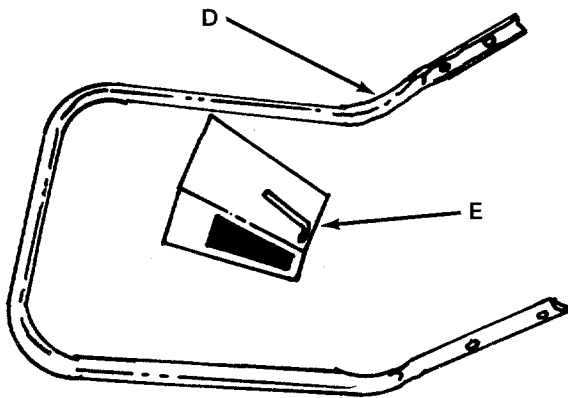

PARTS IN CARTON (See Figure 2):

- D (1) Upper Handle
- E (1) Directional Discharge

FIGURE 2.



NOTE

The right and left side of your leaf blower is determined from operator's position.

1. Remove the leaf blower, hardware pack and all literature from the carton before discarding carton.

2. Figure 3 shows lower handle. Upper handle mounts in center hole only.

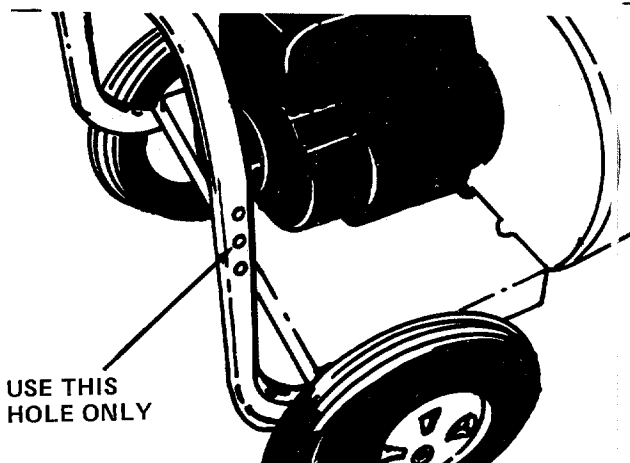

FIGURE 3.

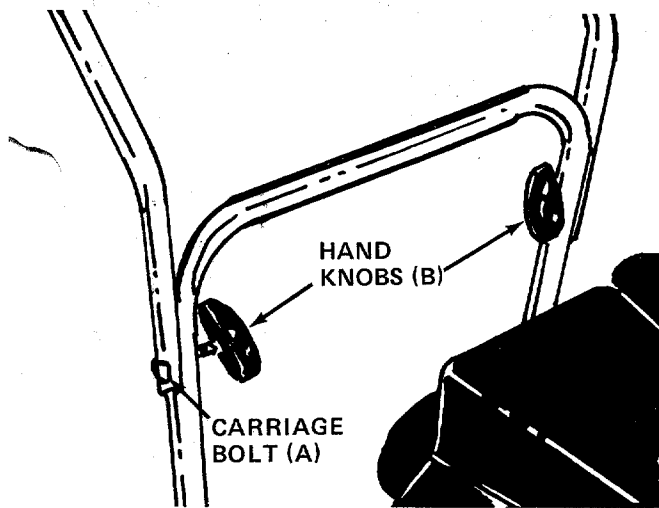

FIGURE 4.

3. Place the upper handle (D) over the lower handle, lining up the holes. Secure with carriage bolts (A) and hand knobs (B). See figure 4.

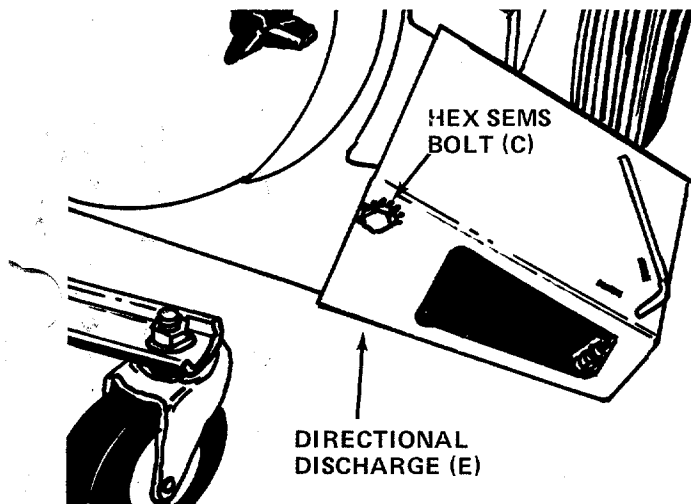

FIGURE 5.

4. Slip end of directional discharge (E) over chute opening. Secure in position with hex sems bolt (C). See figure 5.

OPERATION

BEFORE STARTING ENGINE

Service engine with gas and oil. See engine manual packed with leaf blower for complete instructions for care and maintenance of engine. READ DIRECTIONS CAREFULLY.

TO START ENGINE

1. Move choke lever on engine to choke position.



NOTE

A warm engine may not require choking.

2. Move throttle control lever on engine to START or ON position.
3. Crank engine by pulling recoil starter with a quick, firm stroke. Do not pull out so far the rope stops with a jerk. Do not allow rope and handle to snap back into place.
4. After two or three full firm pulls on recoil (or as soon as engine fires, move choke control to RUN position.

TO STOP ENGINE

1. To stop engine, move throttle control lever to STOP position.
2. Disconnect spark plug wire and ground to prevent accidental starting while equipment is unattended.

ADJUSTMENTS



Do Not make this adjustment or any adjustment with the engine running. Stop the engine, disconnect the spark plug wire and ground plug wire to engine block.

TWO-WAY AIR DISCHARGE

Your leaf blower is equipped with an adjustable chute deflector. Simply push down on handle provided and swing door towards the front or side as desired. See figure 6.

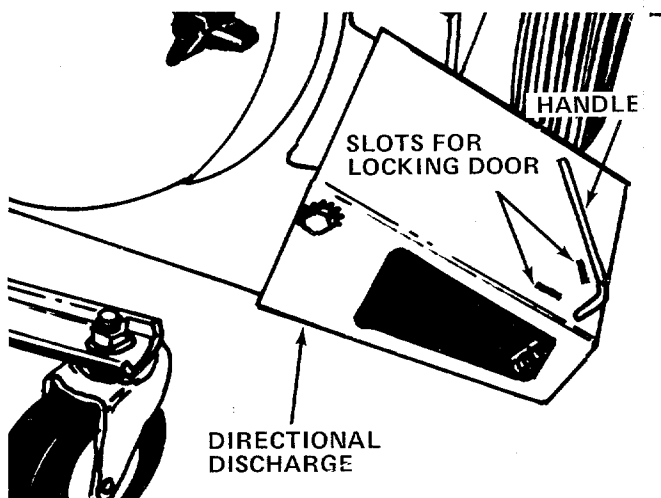

FIGURE 6.

HEIGHT ADJUSTMENT

The height adjustment crank is located on the right hand side of the leaf blower. See figure 7. Turn the crank clockwise to raise the discharge chute. Turn the crank counter-clockwise to lower.

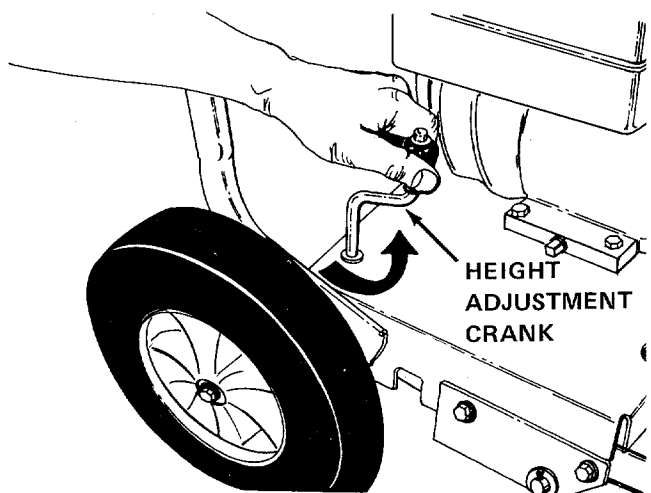

FIGURE 7.

CARBURETOR ADJUSTMENT



If any adjustments are made to the engine while the engine is running (e.g. carburetor), keep clear of all moving parts. Be careful of heated surfaces and muffler.

If carburetor needs adjustment to start or for operation, see "Carburetor Adjustment" section of engine manual.

MAINTENANCE AND LUBRICATION

Your leaf blower, like all machines with moving parts, must receive care and maintenance. The following tips, if used, will contribute many troublefree hours to your blower.

1. Check oil level frequently. When changing oil, make sure dirt and debris is cleaned off oil sump before removing oil plug.
2. Keep blower clean, especially the engine and engine air filter.
3. Check all nuts, bolts and screws occasionally to be sure blower is in good operating condition.
4. The wheel bearings are pre-lubricated at the factory and should require no further attention until blower is serviced. However, it is advisable to remove the wheels and apply a small amount of light oil to each axle at least once a season.

OFF-SEASON STORAGE

If you are going to store your blower for any length of time (30 days or longer), it is important that the following steps be taken:

1. Drain the gas tank. Start the engine. Allow it to run out of gas. Gasoline left in the engine will leave gum deposits in the carburetor and gas tank.
2. Clean engine of all foreign matter.
3. Lubricate cylinder by removing the spark plug and pour in one ounce of clean lubricating oil through the spark plug hole into the cylinder. Crank engine slowly to spread oil and replace spark plug. To start after storage, remove spark plug and rotate engine with starter to remove excess oil.



When storing any type of power equipment in an unventilated or metal storage shed, care should be taken to rust proof the equipment. Using a light oil or silicone, coat the equipment, especially springs and bearings.

TROUBLE SHOOTING CHART

PROBLEM	CAUSE	REMEDY
1. Excessive vibration.	A. Bent crankshaft. B. Vane plate out of balance.	A. Replace crankshaft (should be done by an authorized service dealer). B. Replace vane plate.
2. Engine fails to start.	A. Check fuel tank for gas. B. Spark plug lead wire disconnected. C. Faulty spark plug.	A. Fill tank if empty. B. Connect lead wire. C. Clean, adjust gap or replace. See engine manual.
3. Hard starting or loss of power.	A. Spark plug wire loose. B. Dirty air cleaner.	A. Connect and tighten spark plug wire. B. Clean air cleaner as described in engine manual.
4. Engine overheats.	A. Carburetor not adjusted properly. B. Air flow restricted. C. Engine oil level low.	A. Adjust carburetor. See engine manual. B. Remove blower housing on engine and clean as described in the engine manual. C. Fill crankcase with the proper oil.

NOTE: For repairs beyond the minor adjustments listed above, please contact your local service dealer.

Models 692, 693, 694 and 24695

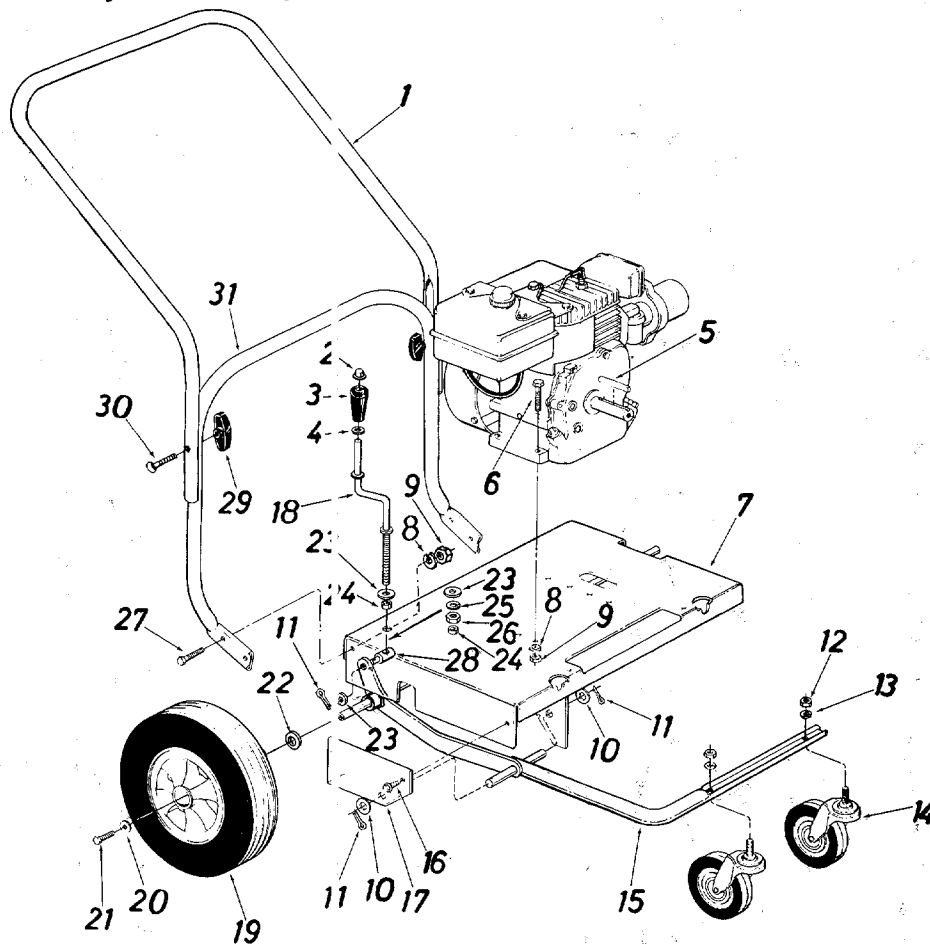

PARTS LIST FOR LEAF BLOWER MODELS 692, 693, 694 and 24695

REF. NO.	PART NO.	COLOR CODE	DESCRIPTION	NEW PART	REF. NO.	PART NO.	COLOR CODE	DESCRIPTION	NEW PART
1	749-0479		Upper Handle		18	747-0542		Height Adjustment Crank	N
2	726-0100		Push Nut 3/8" Rod		19	734-1035		Wheel Ass'y. Comp. 12" x 3" (Plastic) (Incl. Bearings)	
3	720-0171		Crank Knob			734-1184		Wheel Ass'y. Comp. 10.5" x 4" (Steel)	
4	736-0117		Fl.-Wash. .385" I.D. x .62" O.D.			734-1185		Tire Only (For 734-1184 Wheel)	
5	714-0114		Sq. Key 1/4" x 2.0" Lg.*			734-1183		Rim Only (For 734-1184 Wheel)	
6	710-0442		Hex Bolt 5/16-18 x 1.50" Lg.*		20	736-0159		Fl.-Wash. 3/4" I.D. x .87" O.D.	
7	16453		Engine Mounting Frame Ass'y.		21	710-0170		Hex Locking Bolt 5/16-24 x .62" Lg.	
8	736-0119		L.-Wash. 5/16" I.D.*		22	736-0162		Fl.-Wash. (692 Only)	
9	712-0267		Hex Nut 5/16-18 Thd.*		23	736-0300		Fl.-Wash. .38" I.D. x .57" O.D.	
10	736-0187		Fl.-Wash. .63" I.D. x 1.25" O.D.		24	750-0528		Spacer .382" I.D. x .50" O.D. x .180" Lg.	
11	714-0115		Cotter Pin 1/8" Dia. x 1.0" Lg.		25	736-0169		L.-Wash. 3/8" I.D.*	
12	712-0206		Hex Nut 1/2-13 Thd.*		26	712-0354		Hex Nut 3/8-8 Thd.	N
13	736-0921		L.-Wash. 1/2" I.D.*		27	710-0118		Hex Bolt 5/16-18 x .75" Lg.*	N
14	734-1036		Swivel Caster Wheel 5" Dia. x 1.25" Lg.		28	711-0797		Ferrule	N
15	16273		Caster Arm Ass'y.		29	09966		Hand Knob	
16	710-0726		Hex Wash. Hd. "AB" Tap Scr. 5/16" x .75" Lg.		30	710-0487		Carriage Bolt 5/16-18 x 2.0" Lg.	
17	14529		Caster Arm Bracket		31	749-0481		Lower Handle	

Models 692, 693, 694 and 24695

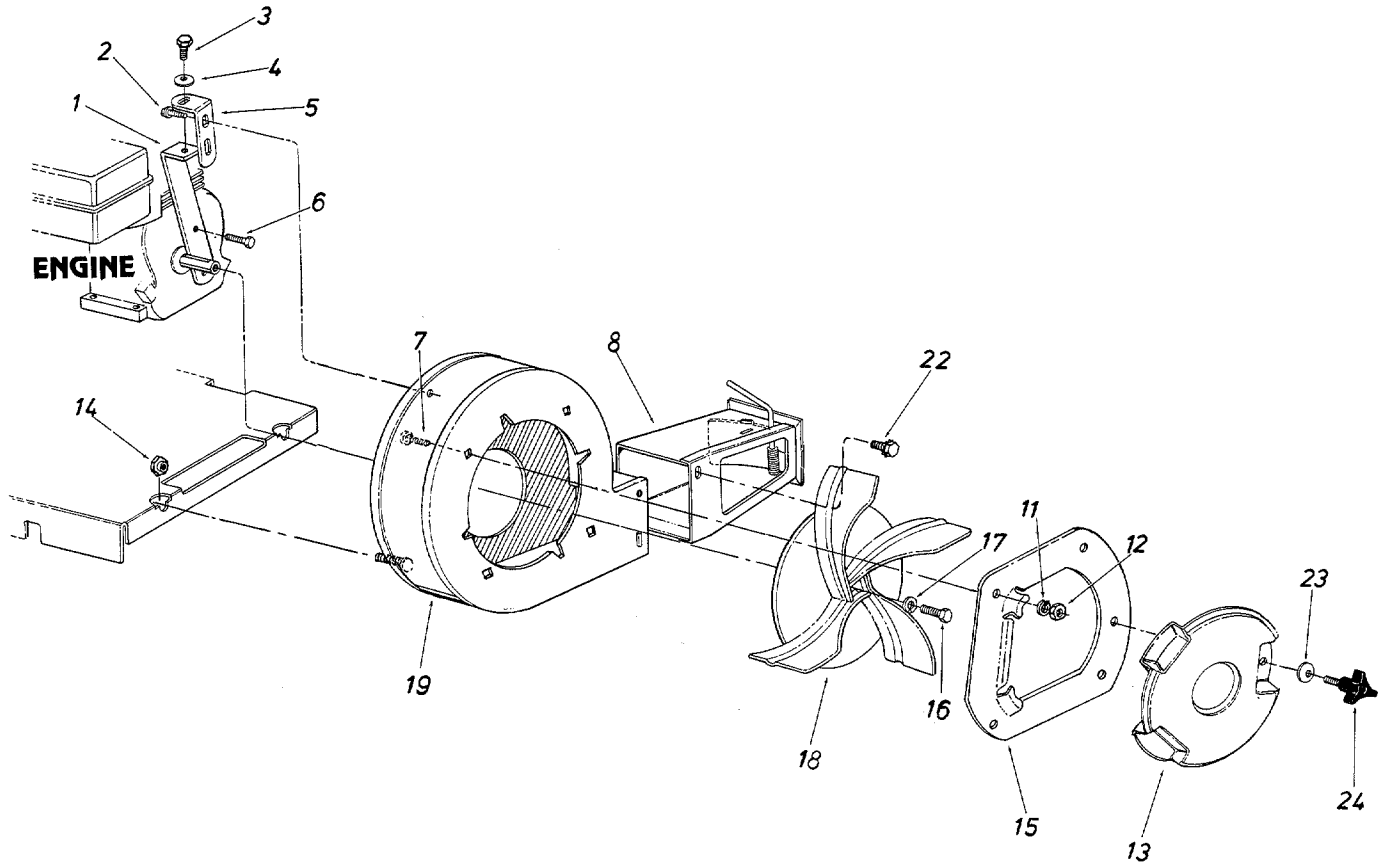

PARTS LIST FOR LEAF BLOWER MODELS 692, 693, 694 and 24695

REF. NO.	PART NO.	COLOR CODE	DESCRIPTION	NEW PART	REF. NO.	PART NO.	COLOR CODE	DESCRIPTION	NEW PART
1	14539		Engine Housing Brace Ass'y.		14	711-0758		Hex Shoulder Nut .50" I.D.	
2	710-0600		Hex Self Tap Scr. 5/16" x .50" Lg.		15	14563 --- 638		Nozzle Plate Ass'y.	
3	710-0118		Hex Bolt 5/16-18 x .75" Lg.*		16	710-0191		Hex Bolt 3/8-24 x 1.25" Lg.*	
4	736-0119		L.-Wash. 5/16" I.D.*		17	736-0217		L.-Wash. 3/8" I.D. HD.	
5	14541		Right Angle Bracket		18	14536 --- 638		Air Vane Plate Ass'y.	
6	710-0627		Hex Locking Bolt 5/16-24 x .75"		19	14496 --- 638		Blower Housing Ass'y. - Comp.	
7	710-0260		Carriage Bolt 5/16-18 x .62" Lg.*		22	710-0259		Hex Sems Bolt 5/16-18 x .62" Lg.*	
8	14479 --- 638		Directional Discharge Ass'y.		23	736-0242		Belleville Wash. 3/4" I.D. x .87" O.D.	
11	736-0119		L.-Wash. 5/16" I.D.*		24	720-0170		3-Arm Thumb Scr. 5/16-18 x .75" Lg.	
12	712-0267		Hex Nut 5/16-18 Thd.*						
13	731-0608		Blower Guard						

*For faster service obtain standard nuts, bolts and washers locally. If these items cannot be obtained locally, order part number and size as shown on parts list.

638—MTD Red
621—Brilliant Fire Mist (24695)

When ordering parts if color or finish is important, use color code shown at left.
[i.e. (part no.)—638 for MTD Red Finish]

The engine is not under warranty by the leaf blower manufacturer. If repairs or service is needed on the engine, please contact your nearest authorized engine service outlet. Check the "Yellow Pages" of your telephone book under "Engines - Gasoline".





1

1

1

