



OM-1572A

August 1993

Processes



Air Plasma Cutting
and Gouging

Description

Air-Cooled Plasma Arc Cutting (PAC)
Torch

APT-1000 Torch

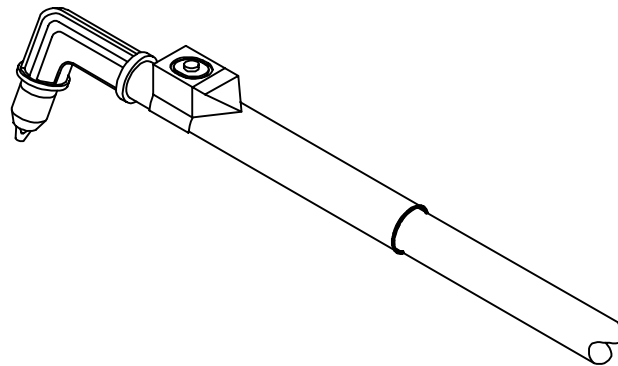

OWNER'S MANUAL



Visit our website at
www.MillerWelds.com

From Miller to You

Thank you and congratulations on choosing Miller. Now you can get the job done and get it done right. We know you don't have time to do it any other way.

That's why when Niels Miller first started building arc welders in 1929, he made sure his products offered long-lasting value and superior quality. Like you, his customers couldn't afford anything less. Miller products had to be more than the best they could be. They had to be the best you could buy.



Today, the people that build and sell Miller products continue the tradition. They're just as committed to providing equipment and service that meets the high standards of quality and value established in 1929.

This Owner's Manual is designed to help you get the most out of your Miller products. Please take time to read the Safety precautions. They will help you protect yourself against potential hazards on the worksite. We've

made installation and operation quick and easy. With Miller you can count on years of reliable service with proper maintenance. And if for some reason the unit needs repair, there's a Troubleshooting section that will help you figure out what the problem is. The parts list will then help you to decide which exact part you may need to fix the problem. Warranty and service information for your particular model are also provided.



Miller is the first welding equipment manufacturer in the U.S.A. to be registered to the ISO 9001 Quality System Standard.

Miller Electric manufactures a full line of welders and welding related equipment. For information on other quality Miller products, contact your local Miller distributor to receive the latest full line catalog or individual catalog sheets. **To locate your nearest distributor or service agency call 1-800-4-A-Miller, or visit us at www.MillerWelds.com on the web.**



Working as hard as you do – every power source from Miller is backed by the most hassle-free warranty in the business.

Miller offers a Technical Manual which provides more detailed service and parts information for your unit. To obtain a Technical Manual, contact your local distributor. Your distributor can also supply you with Welding Process Manuals such as SMAW, GTAW, GMAW, and GMAW-P.



PLASMA ARC CUTTING SAFETY PRECAUTIONS



WARNING

PLASMA ARC CUTTING can be hazardous.

PROTECT YOURSELF AND OTHERS FROM POSSIBLE SERIOUS INJURY OR DEATH. KEEP CHILDREN AWAY. PACEMAKER WEARERS KEEP AWAY UNTIL CONSULTING YOUR DOCTOR.

In cutting, as in most jobs, exposure to certain hazards occurs. Cutting is safe when precautions are taken. The safety information given below is only a summary of the more complete safety information that will be found in the Safety Standards listed on the next page. Read and follow all Safety Standards.

HAVE ALL INSTALLATION, OPERATION, MAINTENANCE, AND REPAIR WORK PERFORMED ONLY BY QUALIFIED PEOPLE.

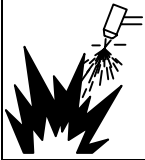

CUTTING can cause fire or explosion.

Hot metal and sparks blow out from the cutting arc. The flying sparks and hot metal, hot workpiece, and hot equipment can cause fires and burns. Check and be sure the area is safe before doing any cutting.

1. Protect yourself and others from flying sparks and hot metal.
2. Do not cut where flying sparks can strike flammable material.
3. Remove all flammables within 35 ft (10.7 m) of the cutting arc. If this is not possible, tightly cover them with approved covers.
4. Be alert that sparks and hot materials from cutting can easily go through small cracks and openings to adjacent areas.
5. Watch for fire, and keep a fire extinguisher nearby.
6. Be aware that cutting on a ceiling, floor, bulkhead, or partition can cause fire on the hidden side.
7. Do not cut on closed containers such as tanks or drums.
8. Connect work cable to the work as close to the cutting area as practical to prevent cutting current from traveling long, possibly unknown paths and causing electric shock and fire hazards.
9. Never cut containers with potentially flammable materials inside – they must be emptied and properly cleaned first.
10. Do not cut in atmospheres containing explosive dust or vapors.
11. Do not cut pressurized cylinders, pipes, or vessels.
12. Do not cut containers that have held combustibles.
13. Wear oil-free protective garments such as leather gloves, heavy shirt, cuffless trousers, high shoes, and a cap.
14. Do not locate unit on or over combustible surfaces.
15. Remove any combustibles, such as a butane lighter or matches, from your person before doing any cutting.



ELECTRIC SHOCK can kill.

Touching live electrical parts can cause fatal shocks or severe burns. The torch and work circuit is electrically live whenever the output is on. The input power circuit and machine internal circuits are also live when power is on. Plasma arc cutting requires higher voltages than welding to start and maintain the arc (200 to 400 volts dc are common), but also uses torches designed with safety interlock systems which turn off the machine when the shield cup is loosened or if tip touches electrode inside the nozzle. Incorrectly installed or improperly grounded equipment is a hazard.

1. Do not touch live electrical parts.
2. Wear dry, hole-free insulating gloves and body protection.
3. Insulate yourself from work and ground using dry insulating mats or covers big enough to prevent any physical contact with the work or ground.
4. Do not touch torch parts if in contact with the work or ground.
5. Turn off power before checking, cleaning, or changing torch parts.
6. Disconnect input power before installing or servicing this equipment. Lockout/tagout input power according to OSHA CFR 1910.147 (see Safety Standards).
7. Properly install and ground this equipment according to its Owner's Manual and national, state, and local codes.
8. Check and be sure that input power cord ground wire is properly connected to ground terminal in disconnect box or that cord plug is connected to a properly grounded receptacle outlet – always verify the supply ground.
9. When making input connections, attach proper grounding conductor first.
10. Frequently inspect input power cord for damage or bare wiring – replace cord immediately if damaged – bare wiring can kill.
11. Turn off all equipment when not in use.
12. Inspect and replace any worn or damaged torch cable leads.
13. Do not wrap torch cable around your body.
14. Ground the workpiece to a good electrical (earth) ground if required by codes.
15. Use only well-maintained equipment. Repair or replace damaged parts at once.
16. Wear a safety harness if working above floor level.
17. Keep all panels and covers securely in place.
18. Do not bypass or try to defeat the safety interlock systems.
19. Use only torch(es) specified in Owner's Manual.
20. Keep away from torch tip and pilot arc when trigger is pressed.
21. Clamp work cable with good metal-to-metal contact to workpiece (not piece that will fall away) or worktable as near the cut as practical.



ARC RAYS can burn eyes and skin.

Arc rays from the cutting process produce intense visible and invisible (ultraviolet and infrared) rays that can burn eyes and skin.

1. Wear face protection (helmet or shield) with correct shade of filter to protect your face and eyes when cutting or watching. ANSI Z49.1 (see Safety Standards) suggests a No. 9 shade (with No. 8 as minimum) for all cutting currents less than 300 amperes. Z49.1 adds that lighter filter shades may be used when the arc is hidden by the workpiece. As this is normally the case with low current cutting, the shades suggested in Table 1 are provided for the operator's convenience.
2. Wear approved safety glasses with side shields.
3. Use protective screens or barriers to protect others from flash and glare; warn others not to watch the arc.
4. Wear protective clothing made from durable, flame-resistant material (wool and leather) and foot protection.



NOISE can damage hearing.

Prolonged noise from some cutting applications can damage hearing if levels exceed limits specified by OSHA (see Safety Standards).

1. Use approved ear plugs or ear muffs if noise level is high.
2. Warn others nearby about noise hazard.

Table 1. Eye Protection For Plasma Arc Cutting

Current Level In Amperes		Minimum Shade Number
Below 20		#4
20 – 40		#5
40 – 60		#6
60 – 80		#8



FUMES AND GASES can be hazardous to your health.

Cutting produces fumes and gases. Breathing these fumes and gases can be hazardous to your health.

1. Keep your head out of the fumes. Do not breathe the fumes.
2. If inside, ventilate the area and/or use exhaust at the arc to remove cutting fumes and gases.
3. If ventilation is poor, use an approved air-supplied respirator.
4. Read the Material Safety Data Sheets (MSDSs) and the manufacturer's instruction for metals to be cut, coatings, and cleaners.

5. Work in a confined space only if it is well ventilated, or while wearing an air-supplied respirator. Fumes from cutting and oxygen depletion can alter air quality causing injury or death. Be sure the breathing air is safe.
6. Do not cut in locations near degreasing, cleaning, or spraying operations. The heat and rays of the arc can react with vapors to form highly toxic and irritating gases.
7. Do not cut on coated metals, such as galvanized, lead, or cadmium plated steel, unless the coating is removed from the cutting area, the area is well ventilated, and if necessary, while wearing an air-supplied respirator. The coatings and any metals containing these elements can give off toxic fumes when cut.
8. Do not cut containers with toxic or reactive materials inside or containers that have held toxic or reactive materials – they must be emptied and properly cleaned first.

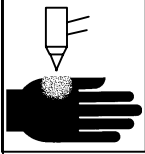

PLASMA ARC can cause injury.

The heat from the plasma arc can cause serious burns. The force of the arc adds greatly to the burn hazard. The intensely hot and powerful arc can quickly cut through gloves and tissue.

1. Keep away from the torch tip.
2. Do not grip material near the cutting path.

3. The pilot arc can cause burns – keep away from torch tip when trigger is pressed.
4. Wear proper flame-retardant clothing covering all exposed body areas.
5. Point torch away from your body and toward work when pressing the torch trigger – pilot arc comes on immediately.
6. Turn off power source and disconnect input power before disassembling torch or changing torch parts.
7. Use only torch(es) specified in the Owner's Manual.

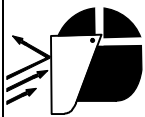

FLYING SPARKS AND HOT METAL can cause injury.

Chipping and grinding cause flying metal. As welds cool, they can throw off slag.

1. Wear approved face shield or safety goggles with side shields.
2. Wear proper body protection to protect skin.
3. Wear flame-resistant ear plugs or ear muffs to prevent sparks from entering ears.

1. Wear approved face shield or safety goggles with side shields.
2. Wear proper body protection to protect skin.
3. Wear flame-resistant ear plugs or ear muffs to prevent sparks from entering ears.

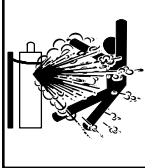

CYLINDERS can explode if damaged.

Gas cylinders contain gas under high pressure. If damaged, a cylinder can explode. Since gas cylinders are normally part of metalworking processes, be sure to treat them carefully.

1. Protect compressed gas cylinders from excessive heat, mechanical shocks, slag, open flame, sparks, and arcs.
2. Install and secure cylinders in an upright position by chaining them to a stationary support or equipment cylinder rack to prevent falling or tipping.

3. Keep cylinders away from any cutting or other electrical circuits.
4. Never allow electrical contact between a plasma arc torch and a cylinder.
5. Never cut on a pressurized cylinder – explosion will result.
6. Use only correct gas cylinders, regulators, hoses, and fittings designed for the specific application; maintain them and associated parts in good condition.
7. Turn face away from valve outlet when opening cylinder valve.
8. Keep protective cap in place over valve except when cylinder is in use or connected for use.
9. Read and follow instructions on compressed gas cylinders, associated equipment, and CGA publication P-1 listed in Safety Standards.

PRINCIPAL SAFETY STANDARDS

Safety in Welding and Cutting, ANSI Standard Z49.1, from American Welding Society, 550 N.W. LeJeune Rd, Miami FL 33126

Safety and Health Standards, OSHA 29 CFR 1910, from Superintendent of Documents, U.S. Government Printing Office, Washington, D.C. 20402.

Recommended Practices for Plasma Arc Cutting, American Welding Society Standard AWS C5.2, from American Welding Society, 550 N.W. LeJeune Rd, Miami, FL 33126

Recommended Safe Practices for the Preparation for Welding and Cutting of Containers That Have Held Hazardous Substances, American Welding Society Standard AWS F4.1, from American Welding Society, 550 N.W. LeJeune Rd, Miami, FL 33126

National Electrical Code, NFPA Standard 70, from National Fire Protection Association, Batterymarch Park, Quincy, MA 02269.

Safe Handling of Compressed Gases in Cylinders, CGA Pamphlet P-1, from Compressed Gas Association, 1235 Jefferson Davis Highway, Suite 501, Arlington, VA 22202.

Code for Safety in Welding and Cutting, CSA Standard W117.2, from Canadian Standards Association, Standards Sales, 178 Rexdale Boulevard, Rexdale, Ontario, Canada M9W 1R3.

Safe Practices For Occupation And Educational Eye And Face Protection, ANSI Standard Z87.1, from American National Standards Institute, 1430 Broadway, New York, NY 10018.

Cutting And Welding Processes, NFPA Standard 51B, from National Fire Protection Association, Batterymarch Park, Quincy, MA 02269.

EMF INFORMATION

NOTE

Considerations About Welding And The Effects Of Low Frequency Electric And Magnetic Fields

The following is a quotation from the General Conclusions Section of the U.S. Congress, Office of Technology Assessment, *Biological Effects of Power Frequency Electric & Magnetic Fields – Background Paper*, OTA-BP-E-53 (Washington, DC: U.S. Government Printing Office, May 1989): “. . . there is now a very large volume of scientific findings based on experiments at the cellular level and from studies with animals and people which clearly establish that low frequency magnetic fields can interact with, and produce changes in, biological systems. While most of this work is of very high quality, the results are complex. Current scientific understanding does not yet allow us to interpret the evidence in a single coherent framework. Even more frustrating, it does not yet allow us to draw definite conclusions about questions of possible risk or to offer clear science-based advice on strategies to minimize or avoid potential risks.”

To reduce magnetic fields in the workplace, use the following procedures:

1. Keep cables close together by twisting or taping them.
2. Arrange cables to one side and away from the operator.
3. Do not coil or drape cables around the body.
4. Keep welding power source and cables as far away as practical.
5. Connect work clamp to workpiece as close to the weld as possible.

About Pacemakers:

The above procedures are among those also normally recommended for pacemaker wearers. Consult your doctor for complete information.

mod10.1 4/93

TABLE OF CONTENTS

SECTION 1 – SAFETY INFORMATION	1
SECTION 2 – SPECIFICATIONS	
2-1. Duty Cycle	2
SECTION 3 – INSTALLATION	
3-1. Consumables And Parts Supplied With Torch	2
3-2. Installing Torch	3
SECTION 4 – OPERATING THE TORCH	4
SECTION 5 – MAINTENANCE & TROUBLESHOOTING	
5-1. Routine Maintenance	6
5-2. Checking Detector Pins And Checking/Replacing Shield Cup, Tip, And Electrode	7
5-3. Troubleshooting	8
SECTION 6 – PARTS LIST	
Figure 6-1. Torch, APT-1000	9

SECTION 1 – SAFETY INFORMATION

mod1.1 2/93



- Read all safety messages throughout this manual.
- Obey all safety messages to avoid injury.
- Learn the meaning of WARNING and CAUTION.

1 → **WARNING**

2 → **ELECTRIC SHOCK can kill.**

3 → Do not touch live electrical parts.
Disconnect input power before installing or servicing.

4 →

5 →

2 → **CAUTION**

MOVING PARTS can injure.

• Keep away from moving parts.
• Keep all panels and covers closed when operating.

6 → **WARNING** **READ SAFETY BLOCKS at start of Section 3-1 before proceeding.**

7 → **NOTE** *Turn Off switch when using high frequency.*

1 Safety Alert Symbol

2 Signal Word

WARNING means possible death or serious injury can happen.

CAUTION means possible minor injury or equipment damage can happen.

3 Statement Of Hazard And Result

4 Safety Instructions To Avoid Hazard

5 Hazard Symbol (If Available)

6 Safety Banner

Read safety blocks for each symbol shown.

7 NOTE

Special instructions for best operation – not related to safety.

Figure 1-1. Safety Information

SECTION 2 – SPECIFICATIONS

Table 2-1. Cutting Torch

Specification	Description
Model Description	APT: Air Plasma Torch; 1000: 10 Ampere Rating
Ampere Rating	10 Amperes At 60% Duty Cycle (See Section 2-1)
Cable Length	15 ft (4.6 m)
Plasma Gas	Air Or Nitrogen Only
Plasma Gas Flow/Pressure	0.6 CFM At 35 PSI (17 L/min At 242 kPa)
Cooling Method	Air
Cutting Capacity	Up To 5/32 in (4 mm) Mild Steel
Overall Dimensions	See Figure 2-1
Weight	Net: 3.5 lb (1.6 kg); Ship: 4.5 lb (2 kg)

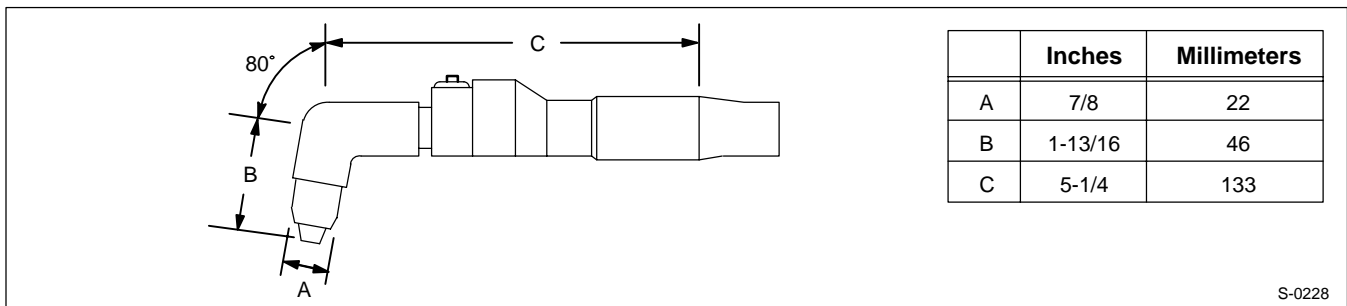

Figure 2-1. Overall Dimensions

2-1. Duty Cycle

CAUTION

EXCEEDING DUTY CYCLE RATINGS will damage power source and torch.

- Do not exceed indicated duty cycles.

warn7.1* 2/92

Duty cycle is how long the torch and power source can operate within a ten minute period without causing overheating or damage. This torch is rated at 60% duty cycle when operated at 10 amperes, allowing cutting 6 minutes out of 10. If the cutting amperes decrease, the duty cycle increases.

SECTION 3 – INSTALLATION

WARNING



ELECTRIC SHOCK can kill.

- Do not touch live electrical parts.
- Turn Off power source, and disconnect input power before installing torch.

swarn3.1* 2/93

3-1. Consumables And Parts Supplied With Torch

 Torch is shipped fully assembled and ready to install onto power source.

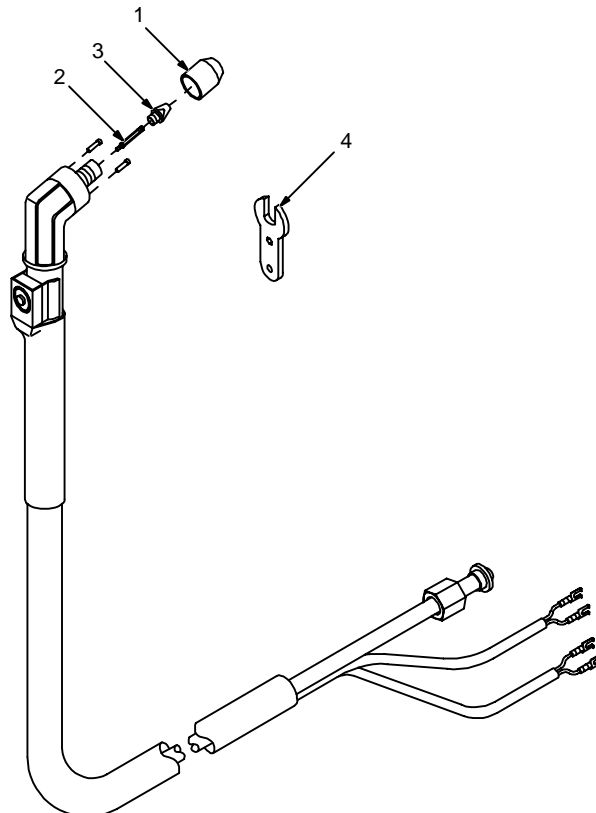

The following consumables are supplied with torch:

- 1 Shield Cup
- 2 Electrode
- 3 Tip
- 4 Wrench

Use supplied wrench to change tips and electrodes (see Section 5-2).

ST-800 225

Figure 3-1. Consumables And Parts Supplied With Torch

3-2. Installing Torch

WARNING



READ SAFETY BLOCK at start of Section 3 before proceeding.

A. Installing Torch In Standard Power Source

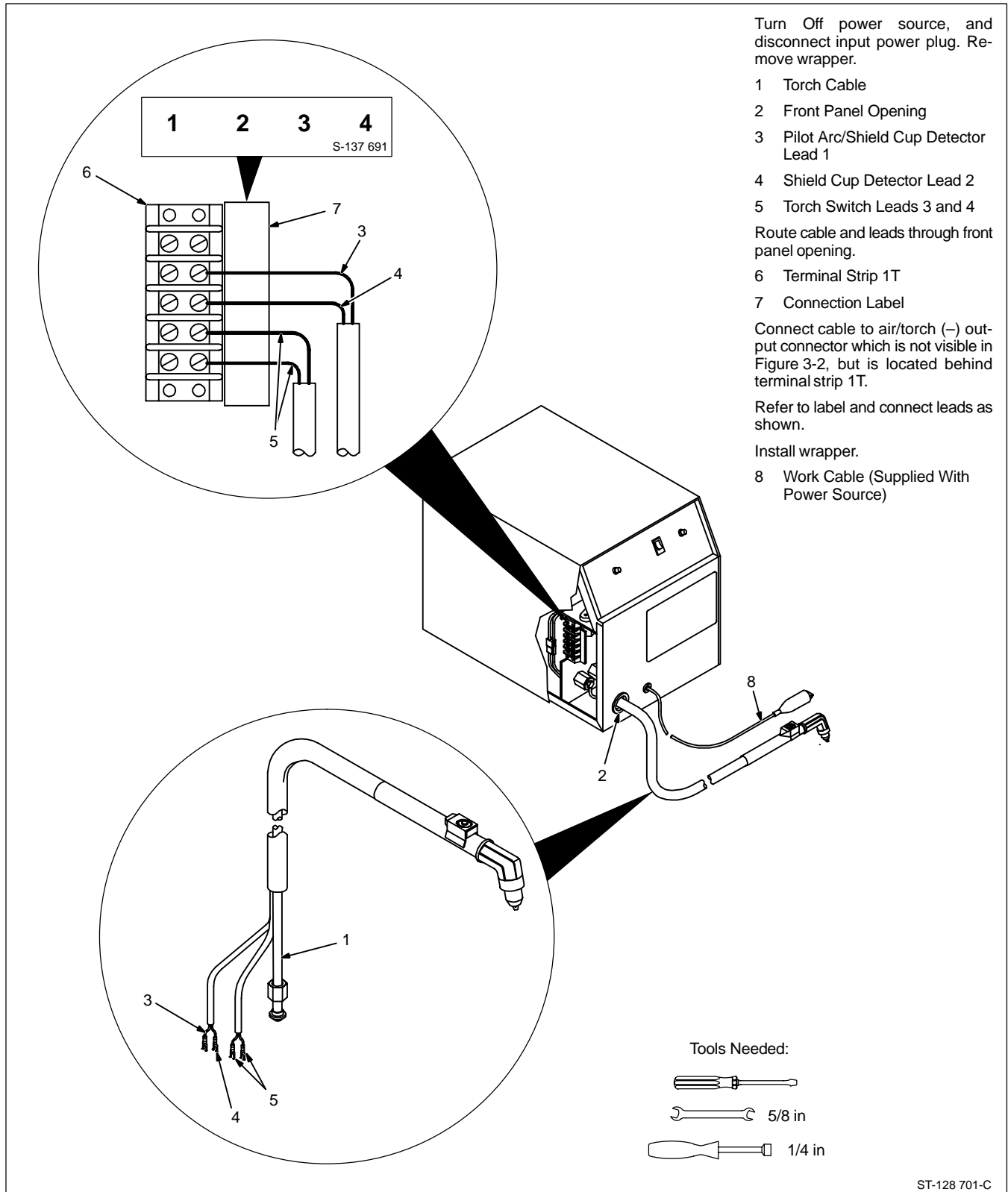

Figure 3-2. Installing Torch In Standard Power Source

B. Installing Torch In Inverter Power Source

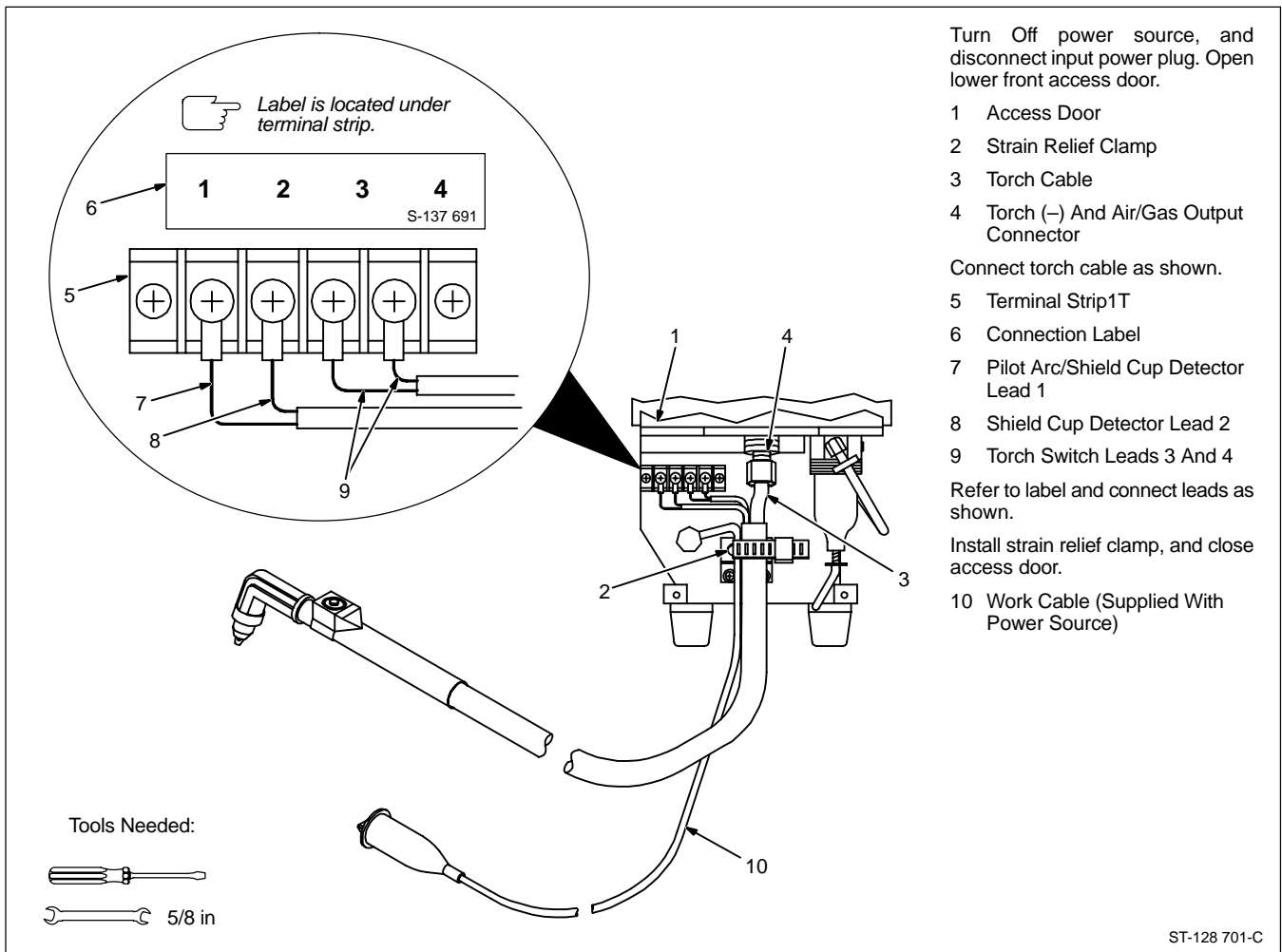







Figure 3-3. Installing Torch In Inverter Power Source

SECTION 4 – OPERATING THE TORCH

 WARNING			
	<p>ELECTRIC SHOCK can kill.</p> <ul style="list-style-type: none"> Always wear dry insulating gloves. Insulate yourself from work and ground. Do not touch live electrical parts. Keep all panels and covers securely in place. 		<p>ARC RAYS can burn eyes and skin; NOISE can damage hearing.</p> <ul style="list-style-type: none"> Wear face protection with correct shade of filter. Wear correct eye, ear, and body protection.
	<p>FUMES AND GASES can be hazardous to your health.</p> <ul style="list-style-type: none"> Keep your head out of the fumes. Ventilate area, or use breathing device. Read Material Safety Data Sheets (MSDSs) and manufacturer's instructions for material cut. 		<p>MOVING PARTS can cause injury.</p> <ul style="list-style-type: none"> Keep away from moving parts. Keep all doors, panels, covers, and guards closed and securely in place.
	<p>CUTTING can cause fire or explosion.</p> <ul style="list-style-type: none"> Do not cut near flammable material. Provide protection from flying sparks. Watch for fire; keep extinguisher nearby. Do not locate unit over combustible surfaces. Do not cut on closed containers. Allow work and equipment to cool before handling. 	<p>See Safety Precautions at beginning of manual for basic cutting safety information.</p>	

swarn6.1* 10/91

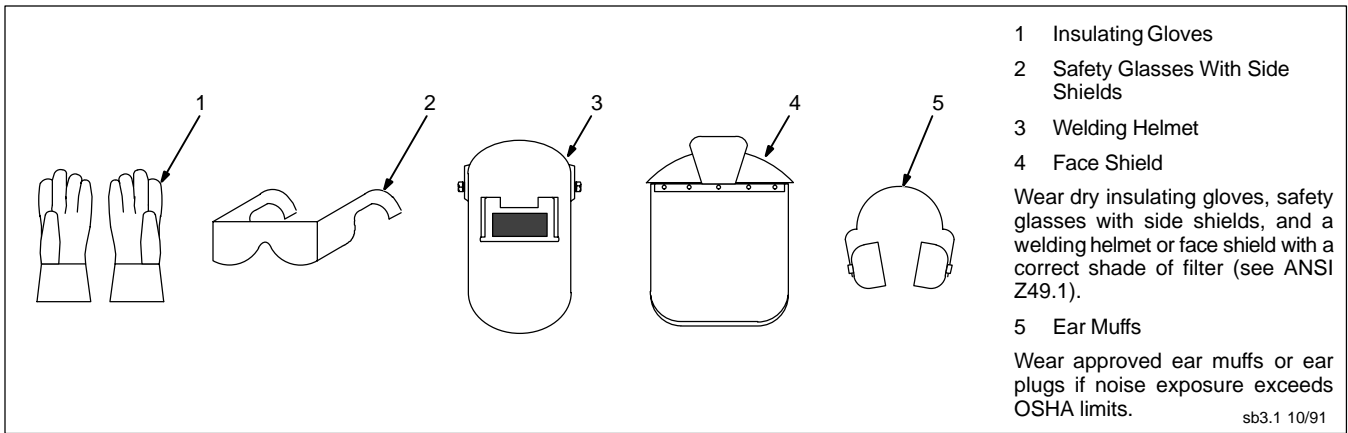

Figure 4-1. Safety Equipment

CAUTION	
<p>HITTING TORCH ON A HARD SURFACE to remove spatter can damage torch.</p> <ul style="list-style-type: none"> Do not clean torch by hitting it against a hard surface. Hitting hard surfaces can damage torch parts and stop proper operation. 	<p>TIP AND ELECTRODE WEAR BEYOND RECOMMENDED VALUES or OPERATION WITHOUT TIP OR ELECTRODE can damage torch.</p> <ul style="list-style-type: none"> Inspect shield cup, tip, and electrode before cutting or whenever cutting speed has been significantly reduced (see Section 5-2). Do not operate torch without a tip or electrode in place.

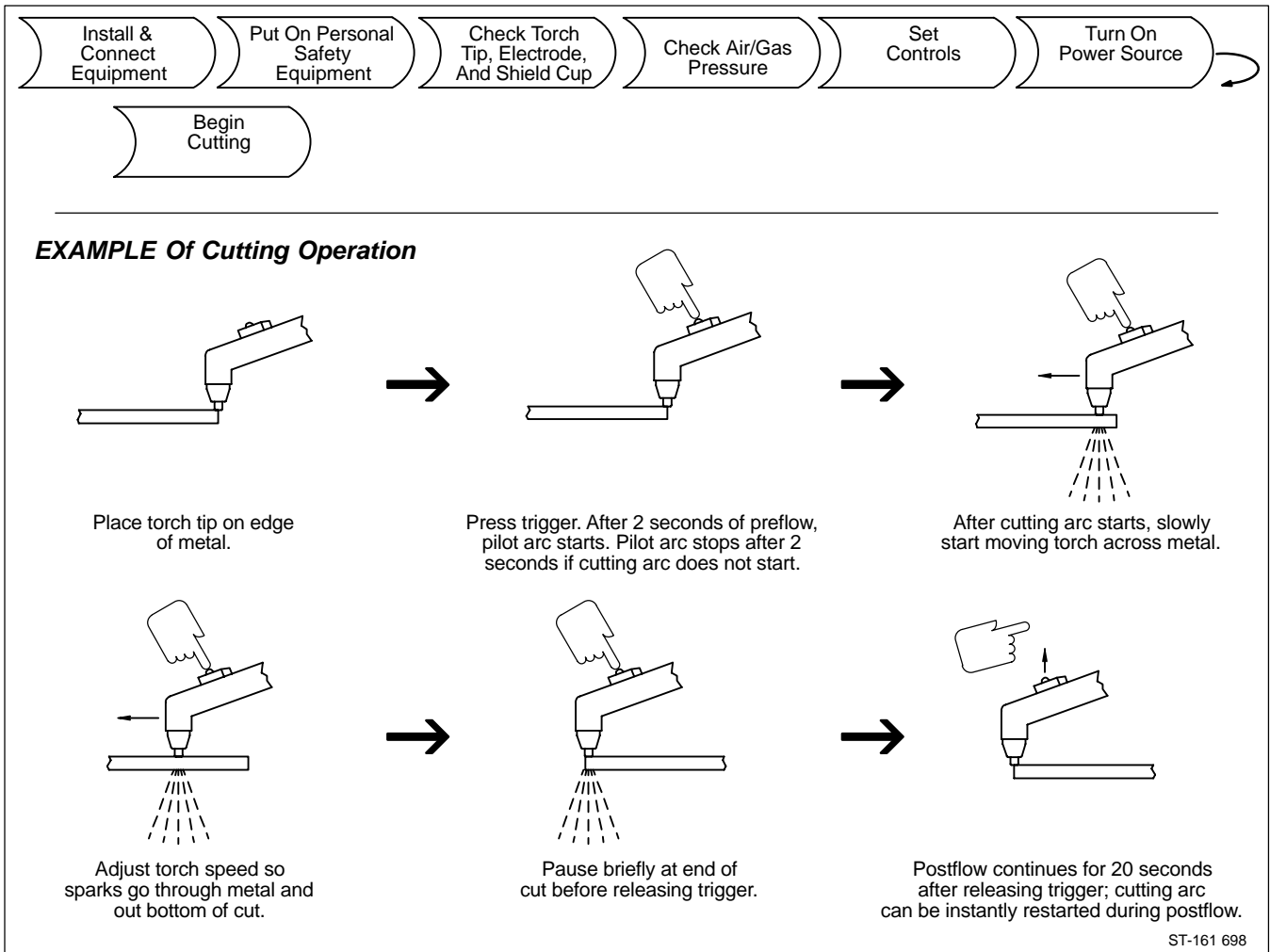







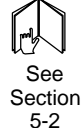
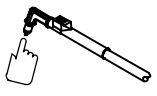

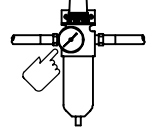
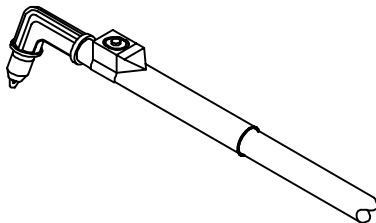

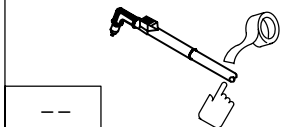
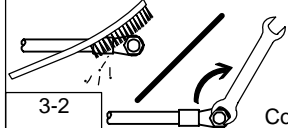
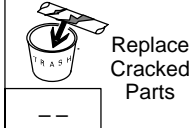



Figure 4-2. Sequence Of Plasma Arc Cutting (PAC)

SECTION 5 – MAINTENANCE & TROUBLESHOOTING

 WARNING	
 <p>ELECTRIC SHOCK can kill.</p> <ul style="list-style-type: none"> Do not touch live electrical parts. Turn Off power source, and disconnect input power before inspecting, maintaining, or servicing. 	 <p>HOT PARTS can cause severe burns.</p> <ul style="list-style-type: none"> Allow cooling period before maintaining or servicing. <p>Maintenance to be performed only by qualified persons.</p>
swarn8.1* 2/93	

5-1. Routine Maintenance

 Turn Off all power before maintaining.

<p> Each Use</p> <div style="display: flex; justify-content: space-between;"> <div style="width: 45%;">  <p>See Section 5-2</p> </div> <div style="width: 45%;">  <p>Check Torch Tip, Electrode, And Shield Cup</p> </div> </div> <div style="display: flex; justify-content: space-between; margin-top: 10px;"> <div style="width: 45%;">  <p>Power Source Manual</p> </div> <div style="width: 45%;">  <p>Check Air/Gas Pressure</p> </div> </div>		<p> 3 Months</p> <div style="display: flex; justify-content: space-between;"> <div style="width: 45%;">  <p>Tape Torn Outer Covering</p> </div> <div style="width: 45%;">  <p>Clean And Tighten Torch Connections</p> </div> </div> <div style="display: flex; justify-content: space-between; margin-top: 10px;"> <div style="width: 45%;">  <p>Replace Cracked Parts</p> </div> <div style="width: 45%;">  <p>Torch Body</p> </div> </div> <div style="display: flex; justify-content: space-between; margin-top: 10px;"> <div style="width: 45%;">  <p>Air/Gas Hose</p> </div> <div style="width: 45%;">  <p>Torch Cable</p> </div> </div>
---	---	--

ST-127 899-A

Figure 5-1. Maintenance Schedule

5-2. Checking Detector Pins And Checking/Replacing Shield Cup, Tip, And Electrode

CAUTION

OVERTIGHTENING will strip threads.

- Do not overtighten electrode, tip, and shield cup during assembly.
- Do not cross-thread parts causing stripping.
- Use care during torch assembly and parts replacement.

TIP AND ELECTRODE WEAR BEYOND RECOMMENDED VALUES or OPERATION WITHOUT TIP OR ELECTRODE can damage torch.

- Inspect shield cup, tip, and electrode before cutting or whenever cutting speed has been significantly reduced.
- Do not operate torch without a tip or electrode in place.
- Be sure to use genuine replacement parts.
- A good practice is to replace both the tip and electrode at the same time.

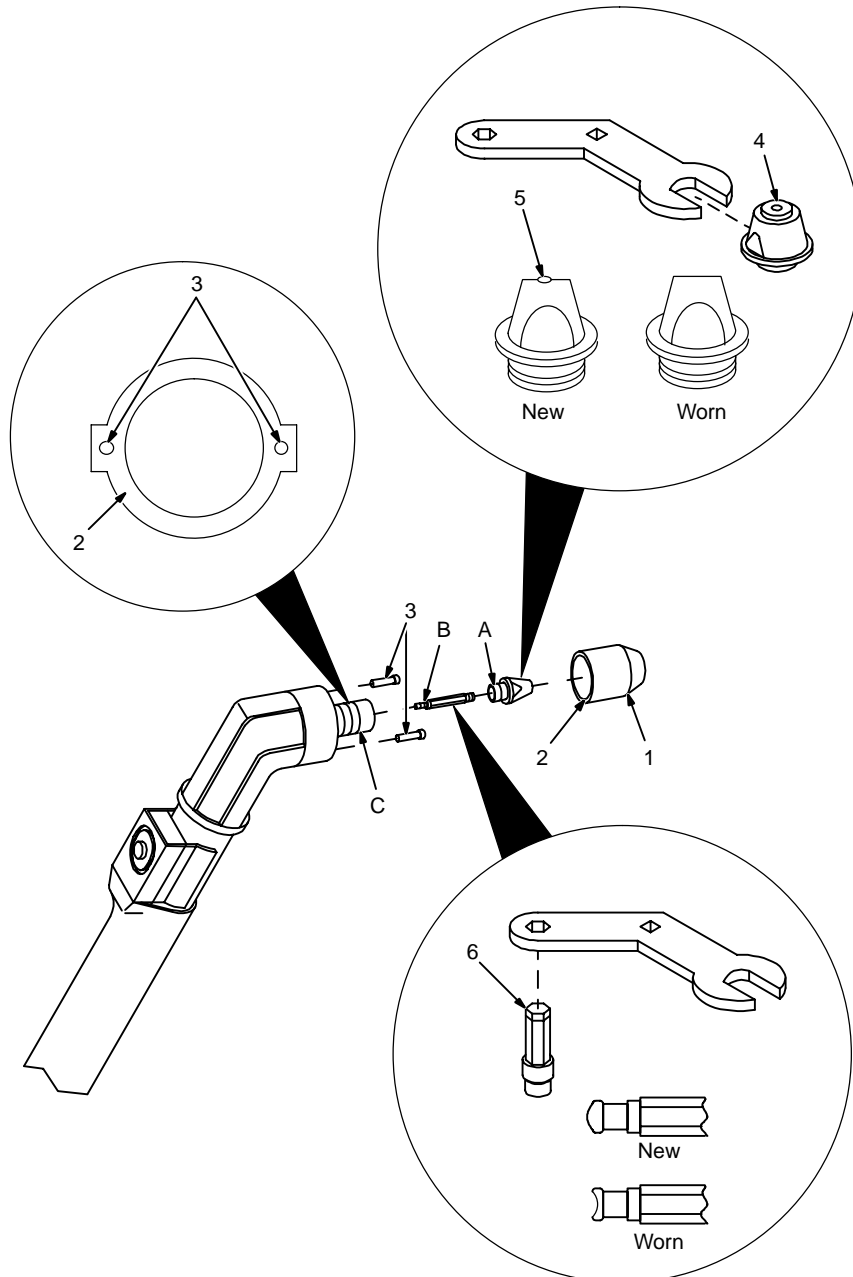

Turn Off power source, and disconnect input power.

- 1 Shield Cup
- 2 Contact Surface
- 3 Detector Pins

Unscrew shield cup, and wipe contact surfaces with a soft cloth. Contact surfaces must be clean so spring-loaded detector pins depress when shield cup is installed. Check shield cup for cracks, and replace if necessary.

Check detector pins to make sure they move freely. If necessary, use electrical contact cleaner to loosen them.

- 4 Tip
- 5 Opening

Remove tip using supplied wrench. Check tip, and replace if opening is deformed or 50% oversize.

- 6 Electrode

Check electrode. If more than 0.039 in (1 mm) of the end is eroded, remove electrode using supplied wrench, and replace.

Carefully reassemble in reverse order.

Thread Sizes:

- A M8 x .75
- B M3 x .5
- C M12 x 1

Figure 5-2. Checking Detector Pins And Checking/Replacing Shield Cup, Tip, And Electrode

5-3. Troubleshooting



 WARNING		
	<p>ELECTRIC SHOCK can kill.</p> <ul style="list-style-type: none"> Do not touch live electrical parts. Turn Off power source, and disconnect input power before inspecting, maintaining, or servicing. 	<div style="text-align: center;">  </div> <p>HOT PARTS can cause severe burns.</p> <ul style="list-style-type: none"> Allow cooling period before maintaining or servicing. <p>Troubleshooting to be performed only by qualified persons.</p>
		swarn8.1* 2/93

Table 5-1. Cutting Trouble

Trouble	Remedy	Section
<div style="border: 1px solid black; padding: 5px; margin-bottom: 5px;">Sparks come out top of cut, or cut is not clean.</div>	Torch travel speed too fast; reduce travel speed.	Figure 4-2
	Check torch tip and electrode, and replace if necessary.	5-2
	Metal being cut is too thick; increase power source Thickness control setting.	*
<div style="border: 1px solid black; padding: 5px; margin-bottom: 5px;">Arc goes out while cutting.</div>	Make sure torch tip is touching metal while cutting.	Figure 4-2
	Be sure work clamp is securely attached.	*
<div style="border: 1px solid black; padding: 5px; margin-bottom: 5px;">Arc goes on and off while cutting.</div>	Torch travel speed is too slow; increase travel speed.	Figure 4-2
	Check torch tip and electrode, and replace if necessary.	5-2

*See power source Owner's Manual.

SECTION 6 – PARTS LIST

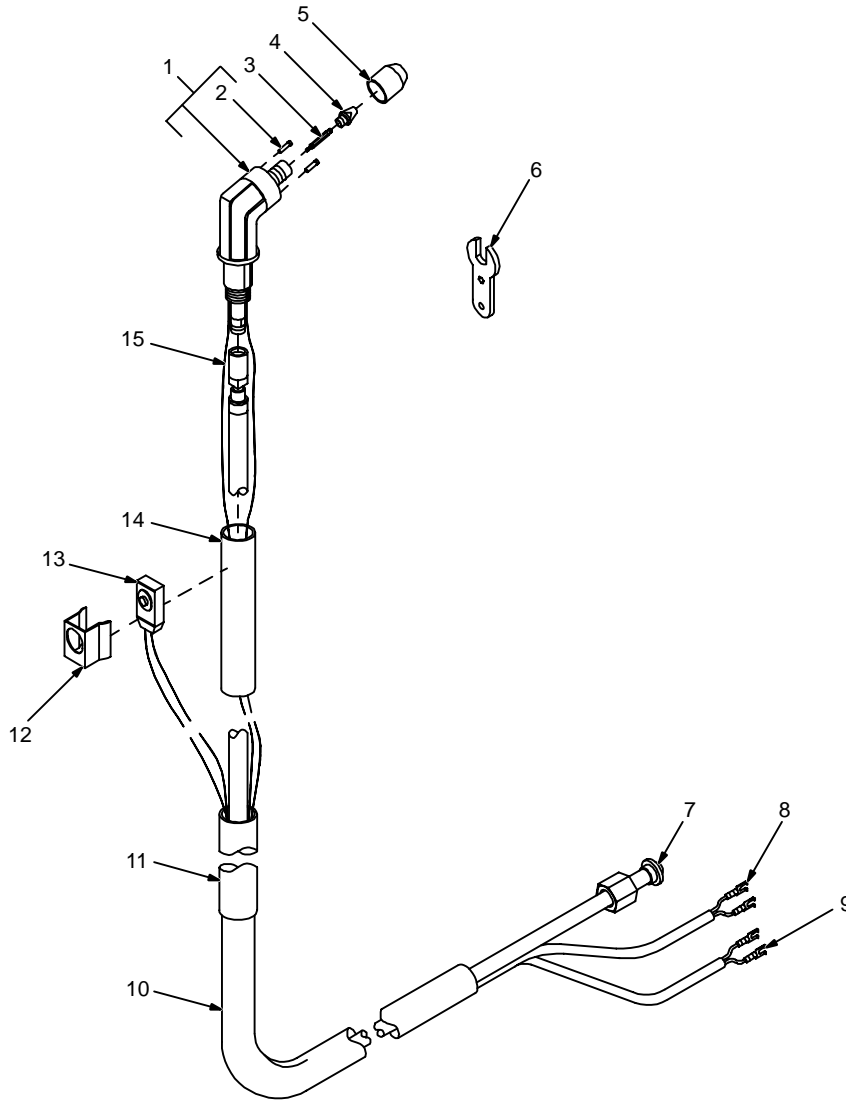

ST-124 813-A

Figure 6-1. Torch, APT-1000

Item No.	Part No.	Description	Quantity
126 796 Figure 6-1. Torch, Model APT-1000			
... 1 ...	131 190 ..	TORCH BODY KIT, (consisting of)	1
... 2 ...	131 184 ...	DETECTIVE PIN	2
... 3 ...	125 032 ..	ELECTRODE	1
... 4 ...	125 031 ..	TIP	1
... 5 ...	125 033 ..	SHIELD CUP	1
... 6 ...	125 034 ..	WRENCH	1
... 7 ...	125 270 ..	POWER CABLE ASSEMBLY	1
... 8 ...	125 078 ..	PILOT AND DETECTIVE LEAD	1
... 9 ...	125 079 ..	TORCH SWITCH LEAD	1
... 10 ...	125 273 ..	HOSE SHEATH	1
... 11 ...	125 269 ..	HEAT SHRINKABLE TUBE	1
... 12 ...	125 268 ..	SWITCH COVER	1
... 13 ...	125 074 ..	TORCH SWITCH	1
... 14 ...	125 266 ..	TORCH HANDLE	1
... 15 ...	125 285 ..	INSULATING TUBE	1

BE SURE TO PROVIDE MODEL AND SERIAL NUMBER WHEN ORDERING REPLACEMENT PARTS.

TRUE BLUE® WARRANTY

Effective January 1, 2000

(Equipment with a serial number preface of "LA" or newer)

This limited warranty supersedes all previous Miller warranties and is exclusive with no other guarantees or warranties expressed or implied.

Warranty Questions?

Call
1-800-4-A-MILLER
for your local
Miller distributor.

Your distributor also gives
you ...

Service

You always get the fast,
reliable response you
need. Most replacement
parts can be in your
hands in 24 hours.

Support

Need fast answers to the
tough welding questions?
Contact your distributor.
The expertise of the
distributor and Miller is
there to help you, every
step of the way.

LIMITED WARRANTY – Subject to the terms and conditions below, Miller Electric Mfg. Co., Appleton, Wisconsin, warrants to its original retail purchaser that new Miller equipment sold after the effective date of this limited warranty is free of defects in material and workmanship at the time it is shipped by Miller. THIS WARRANTY IS EXPRESSLY IN LIEU OF ALL OTHER WARRANTIES, EXPRESS OR IMPLIED, INCLUDING THE WARRANTIES OF MERCHANTABILITY AND FITNESS.

Within the warranty periods listed below, Miller will repair or replace any warranted parts or components that fail due to such defects in material or workmanship. Miller must be notified in writing within thirty (30) days of such defect or failure, at which time Miller will provide instructions on the warranty claim procedures to be followed.

Miller shall honor warranty claims on warranted equipment listed below in the event of such a failure within the warranty time periods. All warranty time periods start on the date that the equipment was delivered to the original retail purchaser, or one year after the equipment is sent to a North American distributor or eighteen months after the equipment is sent to an International distributor.

1. 5 Years Parts – 3 Years Labor
 - * Original main power rectifiers
 - * Inverters (input and output rectifiers only)
2. 3 Years — Parts and Labor
 - * Transformer/Rectifier Power Sources
 - * Plasma Arc Cutting Power Sources
 - * Semi-Automatic and Automatic Wire Feeders
 - * Inverter Power Supplies
 - * Intelligig
 - * Engine Driven Welding Generators
(NOTE: Engines are warranted separately by the engine manufacturer.)
3. 1 Year — Parts and Labor
 - * DS-2 Wire Feeder
 - * Motor Driven Guns (w/exception of Spoolmate 185 & Spoolmate 250)
 - * Process Controllers
 - * Positioners and Controllers
 - * Automatic Motion Devices
 - * RFCS Foot Controls
 - * Induction Heating Power Sources
 - * Water Coolant Systems
 - * HF Units
 - * Grids
 - * Maxstar 140
 - * Spot Welders
 - * Load Banks
 - * Miller Cyclomatic Equipment
 - * Running Gear/Trailers
 - * Plasma Cutting Torches (except APT & SAF Models)
 - * Field Options
(NOTE: Field options are covered under True Blue® for the remaining warranty period of the product they are installed in, or for a minimum of one year — whichever is greater.)
4. 6 Months — Batteries
5. 90 Days — Parts
 - * MIG Guns/TIG Torches
 - * Induction Heating Coils and Blankets

- * APT, ZIPCUT & PLAZCUT Model Plasma Cutting Torches
- * Remote Controls
- * Accessory Kits
- * Replacement Parts (No labor)
- * Spoolmate 185 & Spoolmate 250
- * Canvas Covers

Miller's True Blue® Limited Warranty shall not apply to:

1. **Consumable components; such as contact tips, cutting nozzles, contactors, brushes, slip rings, relays or parts that fail due to normal wear.**
2. Items furnished by Miller, but manufactured by others, such as engines or trade accessories. These items are covered by the manufacturer's warranty, if any.
3. Equipment that has been modified by any party other than Miller, or equipment that has been improperly installed, improperly operated or misused based upon industry standards, or equipment which has not had reasonable and necessary maintenance, or equipment which has been used for operation outside of the specifications for the equipment.

MILLER PRODUCTS ARE INTENDED FOR PURCHASE AND USE BY COMMERCIAL/INDUSTRIAL USERS AND PERSONS TRAINED AND EXPERIENCED IN THE USE AND MAINTENANCE OF WELDING EQUIPMENT.

In the event of a warranty claim covered by this warranty, the exclusive remedies shall be, at Miller's option: (1) repair; or (2) replacement; or, where authorized in writing by Miller in appropriate cases, (3) the reasonable cost of repair or replacement at an authorized Miller service station; or (4) payment of or credit for the purchase price (less reasonable depreciation based upon actual use) upon return of the goods at customer's risk and expense. Miller's option of repair or replacement will be F.O.B., Factory at Appleton, Wisconsin, or F.O.B. at a Miller authorized service facility as determined by Miller. Therefore no compensation or reimbursement for transportation costs of any kind will be allowed.

TO THE EXTENT PERMITTED BY LAW, THE REMEDIES PROVIDED HEREIN ARE THE SOLE AND EXCLUSIVE REMEDIES. IN NO EVENT SHALL MILLER BE LIABLE FOR DIRECT, INDIRECT, SPECIAL, INCIDENTAL OR CONSEQUENTIAL DAMAGES (INCLUDING LOSS OF PROFIT), WHETHER BASED ON CONTRACT, TORT OR ANY OTHER LEGAL THEORY.

ANY EXPRESS WARRANTY NOT PROVIDED HEREIN AND ANY IMPLIED WARRANTY, GUARANTY OR REPRESENTATION AS TO PERFORMANCE, AND ANY REMEDY FOR BREACH OF CONTRACT TORT OR ANY OTHER LEGAL THEORY WHICH, BUT FOR THIS PROVISION, MIGHT ARISE BY IMPLICATION, OPERATION OF LAW, CUSTOM OF TRADE OR COURSE OF DEALING, INCLUDING ANY IMPLIED WARRANTY OF MERCHANTABILITY OR FITNESS FOR PARTICULAR PURPOSE, WITH RESPECT TO ANY AND ALL EQUIPMENT FURNISHED BY MILLER IS EXCLUDED AND DISCLAIMED BY MILLER.

Some states in the U.S.A. do not allow limitations of how long an implied warranty lasts, or the exclusion of incidental, indirect, special or consequential damages, so the above limitation or exclusion may not apply to you. This warranty provides specific legal rights, and other rights may be available, but may vary from state to state.

In Canada, legislation in some provinces provides for certain additional warranties or remedies other than as stated herein, and to the extent that they may not be waived, the limitations and exclusions set out above may not apply. This Limited Warranty provides specific legal rights, and other rights may be available, but may vary from province to province.





Owner's Record

Please complete and retain with your personal records.

Model Name	Serial/Style Number
Purchase Date	(Date which equipment was delivered to original customer.)
Distributor	
Address	
City	
State	Zip



For Service

Call 1-800-4-A-Miller or see our website at www.MillerWelds.com to locate a DISTRIBUTOR or SERVICE AGENCY near you.

Always provide Model Name and Serial/Style Number.

Contact your Distributor for:

- Welding Supplies and Consumables
- Options and Accessories
- Personal Safety Equipment
- Service and Repair
- Replacement Parts
- Training (Schools, Videos, Books)
- Technical Manuals (Servicing Information and Parts)
- Circuit Diagrams
- Welding Process Handbooks

Contact the Delivering Carrier for:

File a claim for loss or damage during shipment.

For assistance in filing or settling claims, contact your distributor and/or equipment manufacturer's Transportation Department.

Miller Electric Mfg. Co.

An Illinois Tool Works Company
1635 West Spencer Street
Appleton, WI 54914 USA

International Headquarters—USA

USA Phone: 920-735-4505 Auto-Attended
USA & Canada FAX: 920-735-4134
International FAX: 920-735-4125

European Headquarters – United Kingdom

Phone: 44 (0) 1204-593493
FAX: 44 (0) 1204-598066

www.MillerWelds.com

