



OM-216 244J

2007-03

**Process**



Stud (SW) Welding

**Description**



Arc Welding Power Source

# PowCon<sup>®</sup> Arc Stud<sup>™</sup> 625 Welding System

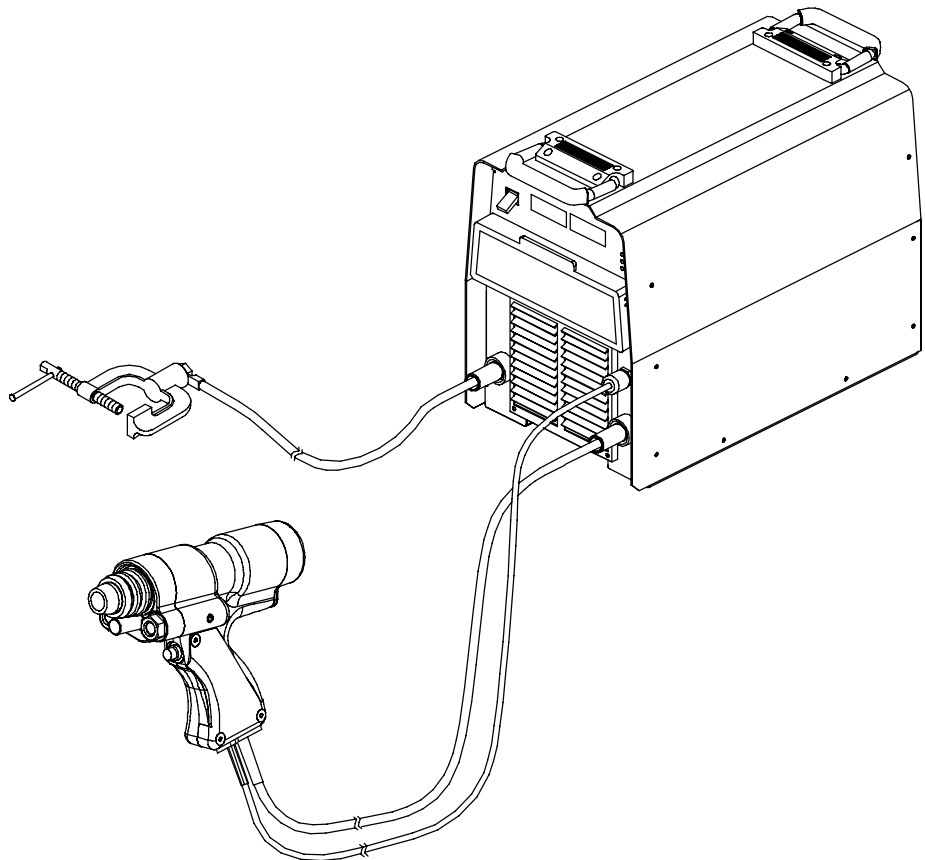

Visit our website at  
[www.MillerWelds.com](http://www.MillerWelds.com)

## OWNER'S MANUAL

File: STUD WELDING (SW)



# From Miller to You

---

*Thank you and congratulations* on choosing Miller. Now you can get the job done and get it done right. We know you don't have time to do it any other way.

That's why when Niels Miller first started building arc welders in 1929, he made sure his products offered long-lasting value and superior quality. Like you, his customers couldn't afford anything less. Miller products had to be more than the best they could be. They had to be the best you could buy.

Today, the people that build and sell Miller products continue the tradition. They're just as committed to providing equipment and service that meets the high standards of quality and value established in 1929.

This Owner's Manual is designed to help you get the most out of your Miller products. Please take time to read the Safety precautions. They will help you protect yourself against potential hazards on the worksite.

We've made installation and operation quick and easy. With Miller you can count on years of reliable service with proper maintenance. And if for some reason the unit needs repair, there's a Troubleshooting section that will help you figure out what the problem is. The parts list will then help you to decide the exact part you may need to fix the problem. Warranty and service information for your particular model are also provided.



Miller is the first welding equipment manufacturer in the U.S.A. to be registered to the ISO 9001:2000 Quality System Standard.

Miller Electric manufactures a full line of welders and welding related equipment. For information on other quality Miller products, contact your local Miller distributor to receive the latest full line catalog or individual specification sheets. **To locate your nearest distributor or service agency call 1-800-4-A-Miller, or visit us at [www.MillerWelds.com](http://www.MillerWelds.com) on the web.**



Working as hard as you do – every power source from Miller is backed by the most hassle-free warranty in the business.



# TABLE OF CONTENTS

<b>SECTION 1 – SAFETY PRECAUTIONS - READ BEFORE USING</b> .....	<b>1</b>
1-1. Symbol Usage .....	1
1-2. Arc Welding Hazards .....	1
1-3. Additional Symbols For Installation, Operation, And Maintenance .....	3
1-4. California Proposition 65 Warnings .....	3
1-5. Principal Safety Standards .....	4
1-6. EMF Information .....	4
<b>SECTION 2 – CONSIGNES DE SÉCURITÉ – LIRE AVANT UTILISATION</b> .....	<b>5</b>
2-1. Symboles utilisés .....	5
2-2. Dangers relatifs au soudage à l'arc .....	5
2-3. Dangers supplémentaires en relation avec l'installation, le fonctionnement et la maintenance .....	7
2-4. Proposition californienne 65 Avertissements .....	7
2-5. Principales normes de sécurité .....	8
2-6. Information EMF .....	8
<b>SECTION 3 – INTRODUCTION</b> .....	<b>9</b>
3-1. Specifications .....	9
3-2. Duty Cycle And Overheating .....	9
<b>SECTION 4 – INSTALLATION - POWER SOURCE</b> .....	<b>10</b>
4-1. Selecting a Location .....	10
4-2. Electrical Service Guide .....	11
4-3. Weld Output Receptacles And Selecting Cable Sizes .....	12
4-4. Connecting 3-Phase Input Power .....	13
4-5. Circuit Breaker .....	14
4-6. 4 Pin Receptacle Information .....	14
4-7. Rack Mounting .....	14
<b>SECTION 5 – INSTALLATION - STUD GUN</b> .....	<b>15</b>
5-1. Chuck Installation .....	15
5-2. Chuck Removal .....	15
5-3. Foot and Leg Setup .....	16
5-4. Ferrule Grip / Spark Shield Removal and Installation .....	16
5-5. Foot Alignment .....	17
5-6. Connecting Stud Gun and Work Clamp to Power Source .....	17
5-7. Plunge Adjustment .....	18
5-8. Adjusting Stud Lift .....	19
<b>SECTION 6 – OPERATION - POWER SOURCE</b> .....	<b>20</b>
6-1. Front Panel Controls .....	20
6-2. Time/Amperage Control .....	22
<b>SECTION 7 – OPERATION - STUD GUN</b> .....	<b>24</b>
7-1. Stud Gun Tool Functions .....	24
7-2. Stud Welding Procedures .....	24
7-3. Welding Sequence .....	25
7-4. Recommended Settings .....	25
<b>SECTION 8 – MAINTENANCE &amp; TROUBLESHOOTING</b> .....	<b>26</b>
8-1. Routine Maintenance .....	26
8-2. Blowing Out Inside Of Unit .....	26
8-3. Maintenance Procedures for Stud Gun .....	28
8-4. Troubleshooting Help Aids .....	30
8-5. Troubleshooting - Power Source .....	30
8-6. Troubleshooting - Stud Gun .....	31
<b>SECTION 9 – ELECTRICAL DIAGRAMS</b> .....	<b>33</b>
<b>SECTION 10 – PARTS LIST FOR POWER SOURCE</b> .....	<b>34</b>
<b>SECTION 11 – PARTS LIST FOR STUD GUN</b> .....	<b>38</b>
<b>SECTION 12 – OPTIONS AND ACCESSORIES</b> .....	<b>40</b>



# SECTION 1 – SAFETY PRECAUTIONS - READ BEFORE USING

som\_3/05

▲ **Warning: Protect yourself and others from injury — read and follow these precautions.**

## 1-1. Symbol Usage



Means Warning! Watch Out! There are possible hazards with this procedure! The possible hazards are shown in the adjoining symbols.

▲ **Marks a special safety message.**

☞ Means "Note"; not safety related.



This group of symbols means Warning! Watch Out! possible ELECTRIC SHOCK, MOVING PARTS, and HOT PARTS hazards. Consult symbols and related instructions below for necessary actions to avoid the hazards.

## 1-2. Arc Welding Hazards

▲ **The symbols shown below are used throughout this manual to call attention to and identify possible hazards. When you see the symbol, watch out, and follow the related instructions to avoid the hazard. The safety information given below is only a summary of the more complete safety information found in the Safety Standards listed in Section 1-5. Read and follow all Safety Standards.**

▲ **Only qualified persons should install, operate, maintain, and repair this unit.**

▲ **During operation, keep everybody, especially children, away.**



### ELECTRIC SHOCK can kill.

Touching live electrical parts can cause fatal shocks or severe burns. The electrode and work circuit is electrically live whenever the output is on. The input power circuit and machine internal circuits are also

live when power is on. In semiautomatic or automatic wire welding, the wire, wire reel, drive roll housing, and all metal parts touching the welding wire are electrically live. Incorrectly installed or improperly grounded equipment is a hazard.

- Do not touch live electrical parts.
- Wear dry, hole-free insulating gloves and body protection.
- Insulate yourself from work and ground using dry insulating mats or covers big enough to prevent any physical contact with the work or ground.
- Do not use AC output in damp areas, if movement is confined, or if there is a danger of falling.
- Use AC output ONLY if required for the welding process.
- If AC output is required, use remote output control if present on unit.
- Additional safety precautions are required when any of the following electrically hazardous conditions are present: in damp locations or while wearing wet clothing; on metal structures such as floors, gratings, or scaffolds; when in cramped positions such as sitting, kneeling, or lying; or when there is a high risk of unavoidable or accidental contact with the workpiece or ground. For these conditions, use the following equipment in order presented: 1) a semiautomatic DC constant voltage (wire) welder, 2) a DC manual (stick) welder, or 3) an AC welder with reduced open-circuit voltage. In most situations, use of a DC, constant voltage wire welder is recommended. And, do not work alone!
- Disconnect input power or stop engine before installing or servicing this equipment. Lockout/tagout input power according to OSHA 29 CFR 1910.147 (see Safety Standards).
- Properly install and ground this equipment according to its Owner's Manual and national, state, and local codes.
- Always verify the supply ground – check and be sure that input power cord ground wire is properly connected to ground terminal in disconnect box or that cord plug is connected to a properly grounded receptacle outlet.
- When making input connections, attach proper grounding conductor first – double-check connections.
- Frequently inspect input power cord for damage or bare wiring – replace cord immediately if damaged – bare wiring can kill.

- Turn off all equipment when not in use.
- Do not use worn, damaged, undersized, or poorly spliced cables.
- Do not drape cables over your body.
- If earth grounding of the workpiece is required, ground it directly with a separate cable.
- Do not touch electrode if you are in contact with the work, ground, or another electrode from a different machine.
- Do not touch electrode holders connected to two welding machines at the same time since double open-circuit voltage will be present.
- Use only well-maintained equipment. Repair or replace damaged parts at once. Maintain unit according to manual.
- Wear a safety harness if working above floor level.
- Keep all panels and covers securely in place.
- Clamp work cable with good metal-to-metal contact to workpiece or worktable as near the weld as practical.
- Insulate work clamp when not connected to workpiece to prevent contact with any metal object.
- Do not connect more than one electrode or work cable to any single weld output terminal.

### SIGNIFICANT DC VOLTAGE exists in inverter-type welding power sources after removal of input power.

- Turn Off inverter, disconnect input power, and discharge input capacitors according to instructions in Maintenance Section before touching any parts.

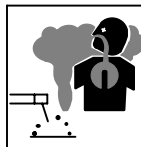

### FUMES AND GASES can be hazardous.

Welding produces fumes and gases. Breathing these fumes and gases can be hazardous to your health.

- Keep your head out of the fumes. Do not breathe the fumes.
- If inside, ventilate the area and/or use local forced ventilation at the arc to remove welding fumes and gases.
- If ventilation is poor, wear an approved air-supplied respirator.
- Read and understand the Material Safety Data Sheets (MSDSs) and the manufacturer's instructions for metals, consumables, coatings, cleaners, and degreasers.
- Work in a confined space only if it is well ventilated, or while wearing an air-supplied respirator. Always have a trained watch-person nearby. Welding fumes and gases can displace air and lower the oxygen level causing injury or death. Be sure the breathing air is safe.
- Do not weld in locations near degreasing, cleaning, or spraying operations. The heat and rays of the arc can react with vapors to form highly toxic and irritating gases.
- Do not weld on coated metals, such as galvanized, lead, or cadmium plated steel, unless the coating is removed from the weld area, the area is well ventilated, and while wearing an air-supplied respirator. The coatings and any metals containing these elements can give off toxic fumes if welded.



### ARC RAYS can burn eyes and skin.

Arc rays from the welding process produce intense visible and invisible (ultraviolet and infrared) rays that can burn eyes and skin. Sparks fly off from the weld.

- Wear an approved welding helmet fitted with a proper shade of filter lenses to protect your face and eyes when welding or watching (see ANSI Z49.1 and Z87.1 listed in Safety Standards).
- Wear approved safety glasses with side shields under your helmet.
- Use protective screens or barriers to protect others from flash, glare and sparks; warn others not to watch the arc.
- Wear protective clothing made from durable, flame-resistant material (leather, heavy cotton, or wool) and foot protection.



### WELDING can cause fire or explosion.

Welding on closed containers, such as tanks, drums, or pipes, can cause them to blow up. Sparks can fly off from the welding arc. The flying sparks, hot workpiece, and hot equipment can cause fires and burns. Accidental contact of electrode to metal objects can cause sparks, explosion, overheating, or fire. Check and be sure the area is safe before doing any welding.

- Remove all flammables within 35 ft (10.7 m) of the welding arc. If this is not possible, tightly cover them with approved covers.
- Do not weld where flying sparks can strike flammable material.
- Protect yourself and others from flying sparks and hot metal.
- Be alert that welding sparks and hot materials from welding can easily go through small cracks and openings to adjacent areas.
- Watch for fire, and keep a fire extinguisher nearby.
- Be aware that welding on a ceiling, floor, bulkhead, or partition can cause fire on the hidden side.
- Do not weld on closed containers such as tanks, drums, or pipes, unless they are properly prepared according to AWS F4.1 (see Safety Standards).
- Connect work cable to the work as close to the welding area as practical to prevent welding current from traveling long, possibly unknown paths and causing electric shock, sparks, and fire hazards.
- Do not use welder to thaw frozen pipes.
- Remove stick electrode from holder or cut off welding wire at contact tip when not in use.
- Wear oil-free protective garments such as leather gloves, heavy shirt, cuffless trousers, high shoes, and a cap.
- Remove any combustibles, such as a butane lighter or matches, from your person before doing any welding.
- Follow requirements in OSHA 1910.252 (a) (2) (iv) and NFPA 51B for hot work and have a fire watcher and extinguisher nearby.

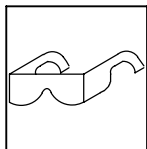

### FLYING METAL can injure eyes.

- Welding, chipping, wire brushing, and grinding cause sparks and flying metal. As welds cool, they can throw off slag.
- Wear approved safety glasses with side shields even under your welding helmet.



### BUILDUP OF GAS can injure or kill.

- Shut off shielding gas supply when not in use.
- Always ventilate confined spaces or use approved air-supplied respirator.



### HOT PARTS can cause severe burns.

- Do not touch hot parts bare handed.
- Allow cooling period before working on gun or torch.
- To handle hot parts, use proper tools and/or wear heavy, insulated welding gloves and clothing to prevent burns.

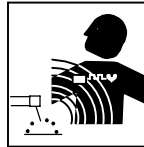

### MAGNETIC FIELDS can affect pacemakers.

- Pacemaker wearers keep away.
- Wearers should consult their doctor before going near arc welding, gouging, or spot welding operations.

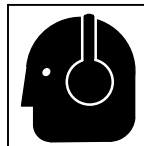

### NOISE can damage hearing.

Noise from some processes or equipment can damage hearing.

- Wear approved ear protection if noise level is high.

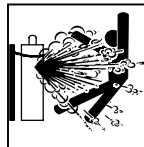

### CYLINDERS can explode if damaged.

Shielding gas cylinders contain gas under high pressure. If damaged, a cylinder can explode. Since gas cylinders are normally part of the welding process, be sure to treat them carefully.

- Protect compressed gas cylinders from excessive heat, mechanical shocks, physical damage, slag, open flames, sparks, and arcs.
- Install cylinders in an upright position by securing to a stationary support or cylinder rack to prevent falling or tipping.
- Keep cylinders away from any welding or other electrical circuits.
- Never drape a welding torch over a gas cylinder.
- Never allow a welding electrode to touch any cylinder.
- Never weld on a pressurized cylinder – explosion will result.
- Use only correct shielding gas cylinders, regulators, hoses, and fittings designed for the specific application; maintain them and associated parts in good condition.
- Turn face away from valve outlet when opening cylinder valve.
- Keep protective cap in place over valve except when cylinder is in use or connected for use.
- Use the right equipment, correct procedures, and sufficient number of persons to lift and move cylinders.
- Read and follow instructions on compressed gas cylinders, associated equipment, and Compressed Gas Association (CGA) publication P-1 listed in Safety Standards.

## 1-3. Additional Symbols For Installation, Operation, And Maintenance



### FIRE OR EXPLOSION hazard.

- Do not install or place unit on, over, or near combustible surfaces.
- Do not install unit near flammables.
- Do not overload building wiring – be sure power supply system is properly sized, rated, and protected to handle this unit.



### FALLING UNIT can cause injury.

- Use lifting eye to lift unit only, NOT running gear, gas cylinders, or any other accessories.
- Use equipment of adequate capacity to lift and support unit.
- If using lift forks to move unit, be sure forks are long enough to extend beyond opposite side of unit.

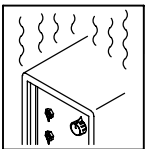

### OVERUSE can cause OVERHEATING

- Allow cooling period; follow rated duty cycle.
- Reduce current or reduce duty cycle before starting to weld again.
- Do not block or filter airflow to unit.

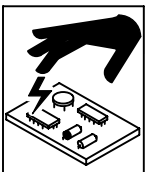

### STATIC (ESD) can damage PC boards.

- Put on grounded wrist strap BEFORE handling boards or parts.
- Use proper static-proof bags and boxes to store, move, or ship PC boards.



### MOVING PARTS can cause injury.

- Keep away from moving parts.
- Keep away from pinch points such as drive rolls.



### WELDING WIRE can cause injury.

- Do not press gun trigger until instructed to do so.
- Do not point gun toward any part of the body, other people, or any metal when threading welding wire.



### MOVING PARTS can cause injury.

- Keep away from moving parts such as fans.
- Keep all doors, panels, covers, and guards closed and securely in place.
- Have only qualified persons remove doors, panels, covers, or guards for maintenance as necessary.
- Reinstall doors, panels, covers, or guards when maintenance is finished and before re-connecting input power.

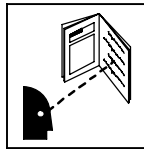

### READ INSTRUCTIONS.

- Read Owner's Manual before using or servicing unit.
- Use only genuine Miller/Hobart replacement parts.

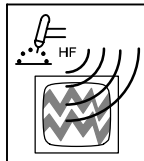

### H.F. RADIATION can cause interference.

- High-frequency (H.F.) can interfere with radio navigation, safety services, computers, and communications equipment.
- Have only qualified persons familiar with electronic equipment perform this installation.
- The user is responsible for having a qualified electrician promptly correct any interference problem resulting from the installation.
- If notified by the FCC about interference, stop using the equipment at once.
- Have the installation regularly checked and maintained.
- Keep high-frequency source doors and panels tightly shut, keep spark gaps at correct setting, and use grounding and shielding to minimize the possibility of interference.

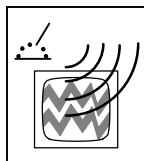

### ARC WELDING can cause interference.

- Electromagnetic energy can interfere with sensitive electronic equipment such as computers and computer-driven equipment such as robots.
- Be sure all equipment in the welding area is electromagnetically compatible.
- To reduce possible interference, keep weld cables as short as possible, close together, and down low, such as on the floor.
- Locate welding operation 100 meters from any sensitive electronic equipment.
- Be sure this welding machine is installed and grounded according to this manual.
- If interference still occurs, the user must take extra measures such as moving the welding machine, using shielded cables, using line filters, or shielding the work area.

## 1-4. California Proposition 65 Warnings

- ▲ **Welding or cutting equipment produces fumes or gases which contain chemicals known to the State of California to cause birth defects and, in some cases, cancer. (California Health & Safety Code Section 25249.5 et seq.)**
- ▲ **Battery posts, terminals and related accessories contain lead and lead compounds, chemicals known to the State of California to cause cancer and birth defects or other reproductive harm. Wash hands after handling.**

### For Gasoline Engines:

- ▲ **Engine exhaust contains chemicals known to the State of California to cause cancer, birth defects, or other reproductive harm.**

### For Diesel Engines:

- ▲ **Diesel engine exhaust and some of its constituents are known to the State of California to cause cancer, birth defects, and other reproductive harm.**

## 1-5. Principal Safety Standards

*Safety in Welding, Cutting, and Allied Processes*, ANSI Standard Z49.1, from Global Engineering Documents (phone: 1-877-413-5184, website: www.global.ihs.com).

*Recommended Safe Practices for the Preparation for Welding and Cutting of Containers and Piping*, American Welding Society Standard AWS F4.1 from Global Engineering Documents (phone: 1-877-413-5184, website: www.global.ihs.com).

*National Electrical Code*, NFPA Standard 70, from National Fire Protection Association, P.O. Box 9101, 1 Battery March Park, Quincy, MA 02269-9101 (phone: 617-770-3000, website: www.nfpa.org).

*Safe Handling of Compressed Gases in Cylinders*, CGA Pamphlet P-1, from Compressed Gas Association, 1735 Jefferson Davis Highway, Suite 1004, Arlington, VA 22202-4102 (phone: 703-412-0900, website: www.cganet.com).

*Code for Safety in Welding and Cutting*, CSA Standard W117.2, from Canadian Standards Association, Standards Sales, 178 Rexdale

Boulevard, Rexdale, Ontario, Canada M9W 1R3 (phone: 800-463-6727 or in Toronto 416-747-4044, website: www.csa-international.org).

*Practice For Occupational And Educational Eye And Face Protection*, ANSI Standard Z87.1, from American National Standards Institute, 11 West 42nd Street, New York, NY 10036-8002 (phone: 212-642-4900, website: www.ansi.org).

*Standard for Fire Prevention During Welding, Cutting, and Other Hot Work*, NFPA Standard 51B, from National Fire Protection Association, P.O. Box 9101, 1 Battery March Park, Quincy, MA 02269-9101 (phone: 617-770-3000, website: www.nfpa.org).

OSHA, Occupational Safety and Health Standards for General Industry, Title 29, Code of Federal Regulations (CFR), Part 1910, Subpart Q, and Part 1926, Subpart J, from U.S. Government Printing Office, Superintendent of Documents, P.O. Box 371954, Pittsburgh, PA 15250 (there are 10 Regional Offices--phone for Region 5, Chicago, is 312-353-2220, website: www.osha.gov).

## 1-6. EMF Information

Considerations About Welding And The Effects Of Low Frequency Electric And Magnetic Fields

Welding current, as it flows through welding cables, will cause electromagnetic fields. There has been and still is some concern about such fields. However, after examining more than 500 studies spanning 17 years of research, a special blue ribbon committee of the National Research Council concluded that: "The body of evidence, in the committee's judgment, has not demonstrated that exposure to power-frequency electric and magnetic fields is a human-health hazard." However, studies are still going forth and evidence continues to be examined. Until the final conclusions of the research are reached, you may wish to minimize your exposure to electromagnetic fields when welding or cutting.

To reduce magnetic fields in the workplace, use the following procedures:

1. Keep cables close together by twisting or taping them.
2. Arrange cables to one side and away from the operator.
3. Do not coil or drape cables around your body.
4. Keep welding power source and cables as far away from operator as practical.
5. Connect work clamp to workpiece as close to the weld as possible.

### **About Pacemakers:**

Pacemaker wearers consult your doctor before welding or going near welding operations. If cleared by your doctor, then following the above procedures is recommended.



# SECTION 2 – CONSIGNES DE SÉCURITÉ – LIRE AVANT UTILISATION

som \_3/05

▲ **Avertissement : se protéger et protéger les autres contre le risque de blessure — lire et respecter ces consignes.**

## 2-1. Symboles utilisés



Symbole graphique d'avertissement ! Attention ! Cette procédure comporte des risques possibles ! Les dangers éventuels sont représentés par les symboles graphiques joints.



Ce groupe de symboles signifie Avertissement ! Attention ! Risques d'ÉLECTROCUTION, ORGANES MOBILES et PARTIES CHAUDES. Consulter les symboles et les instructions afférentes ci-dessous concernant les mesures à prendre pour supprimer les dangers.

▲ **Indique un message de sécurité particulier**

☞ Signifie NOTE ; n'est pas relatif à la sécurité.

## 2-2. Dangers relatifs au soudage à l'arc

▲ **Les symboles représentés ci-dessous sont utilisés dans ce manuel pour attirer l'attention et identifier les dangers possibles. En présence de l'un de ces symboles, prendre garde et suivre les instructions afférentes pour éviter tout risque. Les instructions en matière de sécurité indiquées ci-dessous ne constituent qu'un sommaire des instructions de sécurité plus complètes fournies dans les normes de sécurité énumérées dans la Section 2-5. Lire et observer toutes les normes de sécurité.**

▲ **Seul un personnel qualifié est autorisé à installer, faire fonctionner, entretenir et réparer cet appareil.**

▲ **Pendant le fonctionnement, maintenir à distance toutes les personnes, notamment les enfants de l'appareil.**



**UNE DÉCHARGE ÉLECTRIQUE peut entraîner la mort.**

Le contact d'organes électriques sous tension peut provoquer des accidents mortels ou des brûlures graves. Le circuit de l'électrode et de la pièce est sous tension lorsque le courant est délivré à la sortie. Le circuit d'alimentation et les circuits internes de la machine sont également sous tension lorsque l'alimentation est sur Marche. Dans le mode de soudage avec du fil, le fil, le dérouleur, le bloc de commande du rouleau et toutes les parties métalliques en contact avec le fil sont sous tension électrique. Un équipement installé ou mis à la terre de manière incorrecte ou impropre constitue un danger.

- Ne pas toucher aux pièces électriques sous tension.
- Porter des gants isolants et des vêtements de protection secs et sans trous.
- S'isoler de la pièce à couper et du sol en utilisant des housses ou des tapis assez grands afin d'éviter tout contact physique avec la pièce à couper ou le sol.
- Ne pas se servir de source électrique à courant électrique dans les zones humides, dans les endroits confinés ou là où on risque de tomber.
- Se servir d'une source électrique à courant électrique UNIQUEMENT si le procédé de soudage le demande.
- Si l'utilisation d'une source électrique à courant électrique s'avère nécessaire, se servir de la fonction de télécommande si l'appareil en est équipé.
- D'autres consignes de sécurité sont nécessaires dans les conditions suivantes : risques électriques dans un environnement humide ou si l'on porte des vêtements mouillés ; sur des structures métalliques telles que sols, grilles ou échafaudages ; en position coincée comme assise, à genoux ou couchée ; ou s'il y a un risque élevé de contact inévitable ou accidentel avec la pièce à souder ou le sol. Dans ces conditions, utiliser les équipements suivants, dans l'ordre indiqué : 1) un poste à souder DC à tension constante (à fil), 2) un poste à souder DC manuel (électrode) ou 3) un poste à souder AC à tension à vide réduite. Dans la plupart des situations, l'utilisation d'un poste à souder DC à fil à tension constante est recommandée. En outre, ne pas travailler seul !
- Couper l'alimentation ou arrêter le moteur avant de procéder à l'installation, à la réparation ou à l'entretien de l'appareil. Déverrouiller l'alimentation selon la norme OSHA 29 CFR 1910.147 (voir normes de sécurité).
- Installer le poste correctement et le mettre à la terre convenablement selon les consignes du manuel de l'opérateur et les normes nationales, provinciales et locales.
- Toujours vérifier la terre du cordon d'alimentation. Vérifier et s'assurer que le fil de terre du cordon d'alimentation est bien raccordé à la borne de terre du sectionneur ou que la fiche du cordon est raccordée à une prise correctement mise à la terre.
- En effectuant les raccordements d'entrée, fixer d'abord le conducteur de mise à la terre approprié et contre-vérifier les connexions.

- Vérifier fréquemment le cordon d'alimentation afin de s'assurer qu'il n'est pas altéré ou à nu, le remplacer immédiatement s'il l'est. Un fil à nu peut entraîner la mort.
- L'équipement doit être hors tension lorsqu'il n'est pas utilisé.
- Ne pas utiliser des câbles usés, endommagés, de grosseur insuffisante ou mal épluchés.
- Ne pas enrouler les câbles autour du corps.
- Si la pièce soudée doit être mise à la terre, le faire directement avec un câble distinct.
- Ne pas toucher l'électrode quand on est en contact avec la pièce, la terre ou une électrode provenant d'une autre machine.
- Ne pas toucher des porte électrodes connectés à deux machines en même temps à cause de la présence d'une tension à vide doublée.
- N'utiliser qu'un matériel en bon état. Réparer ou remplacer sur-le-champ les pièces endommagées. Entretien l'appareil conformément à ce manuel.
- Porter un harnais de sécurité si l'on doit travailler au-dessus du sol.
- S'assurer que tous les panneaux et couvercles sont correctement en place.
- Fixer le câble de retour de façon à obtenir un bon contact métal-métal avec la pièce à souder ou la table de travail, le plus près possible de la soudure.
- Isoler la pince de masse quand pas mis à la pièce pour éviter le contact avec tout objet métallique.
- Ne pas raccorder plus d'une électrode ou plus d'un câble de masse à une même borne de sortie de soudage.

**Il reste une TENSION DC NON NÉGLIGEABLE dans les sources de soudage onduleur quand on a coupé l'alimentation.**

- Arrêter les convertisseurs, débrancher le courant électrique et décharger les condensateurs d'alimentation selon les instructions indiquées dans la partie Entretien avant de toucher les pièces.

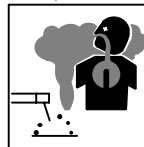

**LES FUMÉES ET LES GAZ peuvent être dangereux.**

Le soudage génère des fumées et des gaz. Leur inhalation peut être dangereuse pour la santé.

- Ne pas mettre sa tête au-dessus des vapeurs. Ne pas respirer ces vapeurs.
- À l'intérieur, ventiler la zone et/ou utiliser une ventilation forcée au niveau de l'arc pour l'évacuation des fumées et des gaz de soudage.
- Si la ventilation est médiocre, porter un respirateur anti-vapeurs approuvé.
- Lire et comprendre les spécifications de sécurité des matériaux (MSDS) et les instructions du fabricant concernant les métaux, les consommables, les revêtements, les nettoyants et les dégraisseurs.
- Travailler dans un espace fermé seulement s'il est bien ventilé ou en portant un respirateur à alimentation d'air. Demander toujours à un surveillant dûment formé de se tenir à proximité. Des fumées et des gaz de soudage peuvent déplacer l'air et abaisser le niveau d'oxygène provoquant des blessures ou des accidents mortels. S'assurer que l'air de respiration ne présente aucun danger.
- Ne pas souder dans des endroits situés à proximité d'opérations de dégraissage, de nettoyage ou de pulvérisation. La chaleur et les rayons de l'arc peuvent réagir en présence de vapeurs et former des gaz hautement toxiques et irritants.
- Ne pas souder des métaux munis d'un revêtement, tels que l'acier galvanisé, plaqué en plomb ou au cadmium à moins que le revêtement n'ait été enlevé dans la zone de soudure, que l'endroit soit bien ventilé et en portant un respirateur à alimentation d'air. Les revêtements et tous les métaux renfermant ces éléments peuvent dégager des fumées toxiques en cas de soudage.



### LES RAYONS D'ARC peuvent entraîner des brûlures aux yeux et à la peau.

Le rayonnement de l'arc du procédé de soudage génère des rayons visibles et invisibles intenses (ultraviolets et infrarouges) susceptibles de provoquer des brûlures dans les yeux et sur la peau.

Des étincelles sont projetées pendant le soudage.

- Porter un casque de soudage approuvé muni de verres filtrants appropriés pour protéger visage et yeux pendant le soudage (voir ANSI Z49.1 et Z87.1 énumérés dans les normes de sécurité).
- Porter des lunettes de sécurité avec écrans latéraux même sous votre casque.
- Avoir recours à des écrans protecteurs ou à des rideaux pour protéger les autres contre les rayonnements les éblouissements et les étincelles ; prévenir toute personne sur les lieux de ne pas regarder l'arc.
- Porter des vêtements confectionnés avec des matières résistantes et ignifuges (cuir, coton lourd ou laine) et des bottes de protection.



### LE SOUDAGE peut provoquer un incendie ou une explosion.

Le soudage effectué sur des conteneurs fermés tels que des réservoirs, tambours ou des conduites peut provoquer leur éclatement. Des étincelles peuvent être projetées de l'arc de soudure. La projection d'étincelles, des pièces chaudes et des équipements chauds peuvent provoquer des incendies et des brûlures. Le contact accidentel de l'électrode avec des objets métalliques peut provoquer des étincelles, une explosion, une surchauffe ou un incendie. Avant de commencer le soudage, vérifier et s'assurer que l'endroit ne présente pas de danger.

- Déplacer toutes les substances inflammables à une distance de 10,7 m de l'arc de soudage. En cas d'impossibilité, les recouvrir soigneusement avec des protections homologuées.
- Ne pas souder dans un endroit où des étincelles peuvent tomber sur des substances inflammables.
- Se protéger, ainsi que toute autre personne travaillant sur les lieux, contre les étincelles et le métal chaud.
- Des étincelles et des matériaux chauds du soudage peuvent facilement passer dans d'autres zones en traversant de petites fissures et des ouvertures.
- Afin d'éliminer tout risque de feu, être vigilant et garder toujours un extincteur à la portée de main.
- Le soudage effectué sur un plafond, plancher, paroi ou séparation peut déclencher un incendie de l'autre côté.
- Ne pas effectuer le soudage sur des conteneurs fermés tels que des réservoirs, tambours, ou conduites, à moins qu'ils n'aient été préparés correctement conformément à AWS F4.1 (voir les normes de sécurité).
- Brancher le câble de masse sur la pièce la plus près possible de la zone de soudage pour éviter le transport du courant sur une longue distance par des chemins inconnus éventuels en provoquant des risques d'électrocution, d'étincelles et d'incendie.
- Ne pas utiliser le poste de soudage pour dégelier des conduites gelées.
- En cas de non-utilisation, enlever la baguette d'électrode du porte-électrode ou couper le fil à la pointe de contact.
- Porter des vêtements de protection exempts d'huile tels que des gants en cuir, une veste résistante, des pantalons sans revers, des bottes et un casque.
- Avant de souder, retirer toute substance combustible de ses poches telles qu'un allumeur au butane ou des allumettes.
- Suivre les consignes de OSHA 1910.252 (a) (2) (iv) et de NFPA 51B pour travaux de soudage et prévoir un détecteur d'incendie et un extincteur à proximité.

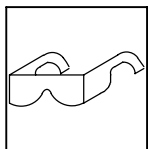

### DES PARTICULES VOLANTES peuvent blesser les yeux.

- Le soudage, l'écaillage, le passage de la pièce à la brosse en fil de fer, et le meulage génèrent des étincelles et des particules métalliques volantes. Pendant la période de refroidissement des soudures, elles risquent de projeter du laitier.
- Porter des lunettes de sécurité avec écrans latéraux ou un écran facial.

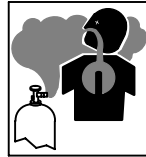

### LES ACCUMULATIONS DE GAZ risquent de provoquer des blessures ou même la mort.

- Fermer l'alimentation du gaz protecteur en cas de non-utilisation.
- Veiller toujours à bien aérer les espaces confinés ou se servir d'un respirateur d'adduction d'air homologué.



### DES PIÈCES CHAUDES peuvent provoquer des brûlures graves.

- Ne pas toucher des parties chaudes à mains nues.
- Prévoir une période de refroidissement avant d'utiliser le pistolet ou la torche.
- Ne pas toucher aux pièces chaudes, utiliser les outils recommandés et porter des gants de soudage et des vêtements épais pour éviter les brûlures.

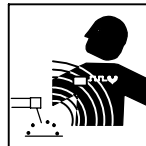

### LES CHAMPS MAGNÉTIQUES peuvent affecter les stimulateurs cardiaques.

- Porteurs de stimulateur cardiaque, rester à distance.
- Les porteurs d'un stimulateur cardiaque doivent d'abord consulter leur médecin avant de s'approcher des opérations de soudage à l'arc, de gougeage ou de soudage par points.

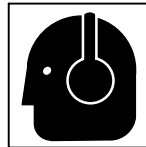

### LE BRUIT peut endommager l'ouïe.

Le bruit des processus et des équipements peut affecter l'ouïe.

- Porter des protections approuvées pour les oreilles si le niveau sonore est trop élevé.

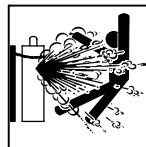

### LES BOUTEILLES peuvent exploser si elles sont endommagées.

Des bouteilles de gaz protecteur contiennent du gaz sous haute pression. Si une bouteille est endommagée, elle peut exploser. Du fait que les bouteilles de gaz font normalement partie du procédé de soudage, les manipuler avec précaution.

- Protéger les bouteilles de gaz comprimé d'une chaleur excessive, des chocs mécaniques, des dommages physiques, du laitier, des flammes ouvertes, des étincelles et des arcs.
- Placer les bouteilles debout en les fixant dans un support stationnaire ou dans un porte-bouteilles pour les empêcher de tomber ou de se renverser.
- Tenir les bouteilles éloignées des circuits de soudage ou autres circuits électriques.
- Ne jamais placer une torche de soudage sur une bouteille à gaz.
- Une électrode de soudage ne doit jamais entrer en contact avec une bouteille.
- Ne jamais souder une bouteille pressurisée – risque d'explosion.
- Utiliser seulement des bouteilles de gaz protecteur, régulateurs, tuyaux et raccords convenables pour cette application spécifique ; les maintenir ainsi que les éléments associés en bon état.
- Détourner votre visage du détendeur-régulateur lorsque vous ouvrez la soupape de la bouteille.
- Le couvercle du détendeur doit toujours être en place, sauf lorsque la bouteille est utilisée ou qu'elle est reliée pour usage ultérieur.
- Utiliser les équipements corrects, les bonnes procédures et suffisamment de personnes pour soulever et déplacer les bouteilles.
- Lire et suivre les instructions sur les bouteilles de gaz comprimé, l'équipement connexe et le dépliant P-1 de la CGA (Compressed Gas Association) mentionné dans les principales normes de sécurité.

## 2-3. Dangers supplémentaires en relation avec l'installation, le fonctionnement et la maintenance



### Risque D'INCENDIE OU D'EXPLOSION.

- Ne pas placer l'appareil sur, au-dessus ou à proximité de surfaces inflammables.
- Ne pas installer l'appareil à proximité de produits inflammables.
- Ne pas surcharger l'installation électrique – s'assurer que l'alimentation est correctement dimensionnée et protégée avant de mettre l'appareil en service.



### LA CHUTE DE L'APPAREIL peut blesser.

- Utiliser l'anneau de levage uniquement pour soulever l'appareil, NON PAS les chariots, les bouteilles de gaz ou tout autre accessoire.
- Utiliser un équipement de levage de capacité suffisante pour lever l'appareil.
- En utilisant des fourches de levage pour déplacer l'unité, s'assurer que les fourches sont suffisamment longues pour dépasser du côté opposé de l'appareil.

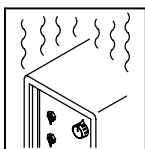

### L'EMPLOI EXCESSIF peut SURCHAUFFER L'ÉQUIPEMENT.

- Prévoir une période de refroidissement ; respecter le cycle opératoire nominal.
- Réduire le courant ou le facteur de marche avant de poursuivre le soudage.
- Ne pas obstruer les passages d'air du poste.

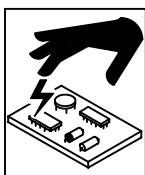

### LES CHARGES ÉLECTROSTATIQUES peuvent endommager les circuits imprimés.

- Établir la connexion avec la barrette de terre avant de manipuler des cartes ou des pièces.
- Utiliser des pochettes et des boîtes antistatiques pour stocker, déplacer ou expédier des cartes PC.

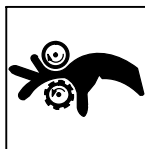

### DES ORGANES MOBILES peuvent provoquer des blessures.

- Ne pas s'approcher des organes mobiles.
- Ne pas s'approcher des points de coincement tels que des rouleaux de commande.



### LES FILS DE SOUDAGE peuvent provoquer des blessures.

- Ne pas appuyer sur la gâchette avant d'en avoir reçu l'instruction.
- Ne pas diriger le pistolet vers soi, d'autres personnes ou toute pièce mécanique en engageant le fil de soudage.



### DES ORGANES MOBILES peuvent provoquer des blessures.

- S'abstenir de toucher des organes mobiles tels que des ventilateurs.
- Maintenir fermés et verrouillés les portes, panneaux, recouvrements et dispositifs de protection.
- Seules des personnes qualifiées sont autorisées à enlever les portes, panneaux, recouvrements ou dispositifs de protection pour l'entretien.
- Remettre les portes, panneaux, recouvrements ou dispositifs de protection quand l'entretien est terminé et avant de rebrancher l'alimentation électrique.

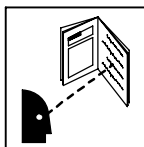

### LIRE LES INSTRUCTIONS.

- Lire le manuel d'utilisation avant d'utiliser ou d'intervenir sur l'appareil.
- Utiliser uniquement des pièces de rechange Miller/Hobart.

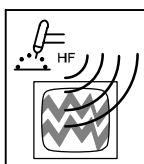

### LE RAYONNEMENT HAUTE FRÉQUENCE (HF) risque de provoquer des interférences.

- Le rayonnement haute fréquence (HF) peut provoquer des interférences avec les équipements de radio-navigation et de communication, les services de sécurité et les ordinateurs.
- Demander seulement à des personnes qualifiées familiarisées avec des équipements électroniques de faire fonctionner l'installation.
- L'utilisateur est tenu de faire corriger rapidement par un électricien qualifié les interférences résultant de l'installation.
- Si le FCC signale des interférences, arrêter immédiatement l'appareil.
- Effectuer régulièrement le contrôle et l'entretien de l'installation.
- Maintenir soigneusement fermés les portes et les panneaux des sources de haute fréquence, maintenir les éclateurs à une distance correcte et utiliser une terre et un blindage pour réduire les interférences éventuelles.

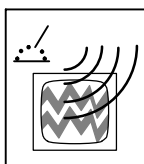

### LE SOUDAGE À L'ARC risque de provoquer des interférences.

- L'énergie électromagnétique peut gêner le fonctionnement d'appareils électroniques comme des ordinateurs et des robots.
- Veiller à ce que tout l'équipement de la zone de soudage soit compatible électromagnétiquement.
- Pour réduire la possibilité d'interférence, maintenir les câbles de soudage aussi courts que possible, les grouper, et les poser aussi bas que possible (ex. par terre).
- Veiller à souder à une distance de 100 mètres de tout équipement électronique sensible.
- Veiller à ce que ce poste de soudage soit posé et mis à la terre conformément à ce mode d'emploi.
- En cas d'interférences après avoir pris les mesures précédentes, il incombe à l'utilisateur de prendre des mesures supplémentaires telles que le déplacement du poste, l'utilisation de câbles blindés, l'utilisation de filtres de ligne ou la pose de protecteurs dans la zone de travail.

## 2-4. Proposition californienne 65 Avertissements

▲ Les équipements de soudage et de coupage produisent des fumées et des gaz qui contiennent des produits chimiques dont l'État de Californie reconnaît qu'ils provoquent des malformations congénitales et, dans certains cas, des cancers. (Code de santé et de sécurité de Californie, chapitre 25249.5 et suivants)

▲ Les batteries, les bornes et autres accessoires contiennent du plomb et des composés à base de plomb, produits chimiques dont l'État de Californie reconnaît qu'ils provoquent des cancers et des malformations congénitales ou autres problèmes de procréation. Se laver les mains après manipulation.

Pour les moteurs à essence :

▲ Les gaz d'échappement des moteurs contiennent des produits chimiques dont l'État de Californie reconnaît qu'ils provoquent des cancers et des malformations congénitales ou autres problèmes de procréation.

Pour les moteurs diesel :

▲ Les gaz d'échappement des moteurs diesel et certains de leurs composants sont reconnus par l'État de Californie comme provoquant des cancers et des malformations congénitales ou autres problèmes de procréation.

## 2-5. Principales normes de sécurité

*Safety in Welding, Cutting, and Allied Processes*, ANSI Standard Z49.1, de Global Engineering Documents (téléphone : 1-877-413-5184, site Internet : [www.global.ihs.com](http://www.global.ihs.com)).

*Recommended Safe Practices for the Preparation for Welding and Cutting of Containers and Piping*, American Welding Society Standard AWS F4.1 de Global Engineering Documents (téléphone : 1-877-413-5184, site Internet : [www.global.ihs.com](http://www.global.ihs.com)).

*National Electrical Code*, NFPA Standard 70, de National Fire Protection Association, P.O. Box 9101, 1 Battery March Park, Quincy, MA 02269-9101 (téléphone : 617-770-3000, site Internet : [www.nfpa.org](http://www.nfpa.org)).

*Safe Handling of Compressed Gases in Cylinders*, CGA Pamphlet P-1, de Compressed Gas Association, 1735 Jefferson Davis Highway, Suite 1004, Arlington, VA 22202-4102 (téléphone : 703-412-0900, site Internet : [www.cganet.com](http://www.cganet.com)).

*Code for Safety in Welding and Cutting*, CSA Standard W117.2, de Canadian Standards Association, Standards Sales, 178 Rexdale

Boulevard, Rexdale, Ontario, Canada M9W 1R3 (téléphone : 800-463-6727 ou à Toronto 416-747-4044, site Internet : [www.csa-international.org](http://www.csa-international.org)).

*Practice For Occupational And Educational Eye And Face Protection*, ANSI Standard Z87.1, de American National Standards Institute, 11 West 42nd Street, New York, NY 10036-8002 (téléphone : 212-642-4900, site Internet : [www.ansi.org](http://www.ansi.org)).

*Standard for Fire Prevention During Welding, Cutting, and Other Hot Work*, NFPA Standard 51B, de National Fire Protection Association, P.O. Box 9101, 1 Battery March Park, Quincy, MA 02269-9101 (téléphone : 617-770-3000, site Internet : [www.nfpa.org](http://www.nfpa.org)).

OSHA, Occupational Safety and Health Standards for General Industry, Title 29, Code of Federal Regulations (CFR), Part 1910, Subpart Q, and Part 1926, Subpart J, de U.S. Government Printing Office, Superintendent of Documents, P.O. Box 371954, Pittsburgh, PA 15250 (il y a 10 bureaux régionaux—le téléphone de la région 5, Chicago, est 312-353-2220, site Internet : [www.osha.gov](http://www.osha.gov)).

## 2-6. Information EMF

Considérations sur le soudage et les effets de basse fréquence et des champs magnétiques et électriques.

Le courant de soudage, pendant son passage dans les câbles de soudage, causera des champs électromagnétiques. Il y a eu et il y a encore un certain souci à propos de tels champs. Cependant, après avoir examiné plus de 500 études qui ont été faites pendant une période de recherche de 17 ans, un comité spécial ruban bleu du National Research Council a conclu : « L'accumulation de preuves, suivant le jugement du comité, n'a pas démontré que l'exposition aux champs magnétiques et champs électriques à haute fréquence représente un risque à la santé humaine ». Toutefois, des études sont toujours en cours et les preuves continuent à être examinées. En attendant que les conclusions finales de la recherche soient établies, il vous serait souhaitable de réduire votre exposition aux champs électromagnétiques pendant le soudage ou le coupage.

Pour réduire les champs magnétiques sur le poste de travail, appliquer les procédures suivantes :

1. Maintenir les câbles ensemble en les tordant ou en les enveloppant.
2. Disposer les câbles d'un côté et à distance de l'opérateur.
3. Ne pas courber pas et ne pas entourer pas les câbles autour de votre corps.
4. Garder le poste de soudage et les câbles le plus loin possible de vous.
5. Connecter la pince sur la pièce aussi près que possible de la soudeuse.

### En ce qui concerne les stimulateurs cardiaques

Les porteurs de stimulateur cardiaque doivent consulter leur médecin avant de souder ou d'approcher des opérations de soudage. Si le médecin approuve, il est recommandé de suivre les procédures précédentes.

# SECTION 3 – INTRODUCTION

## 3-1. Specifications

Rated Welding Output	Amperage Range in CC Mode	Max. Open-Circuit Voltage	RMS Amps Input at Rated Load Output, 60 Hz 3-Phase at NEMA Load Voltages and Class I Rating		KVA	KW
			480 V	575 V		
1000 A at 36 VDC, 3-Phase 27% Duty Cycle	50-1000A	70 VDC	55 (0.10*)	45 (0.08*)	46 (0.09*)	42 (0.04*)

\*While idling  
\*\*See Section 4-2 for additional information.

## 3-2. Duty Cycle And Overheating



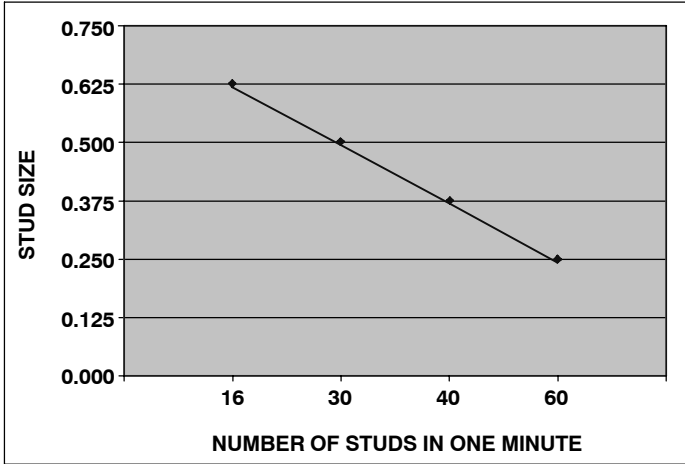

Number of Studs in One Minute	Stud Size
16	0.625
30	0.500
40	0.375
60	0.250

27% Duty Cycle

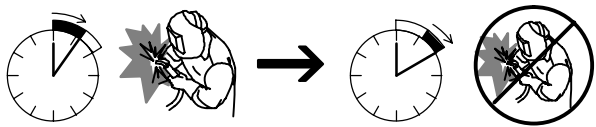

.75 second Welding      3.00 seconds Resting

---

**Overheating**

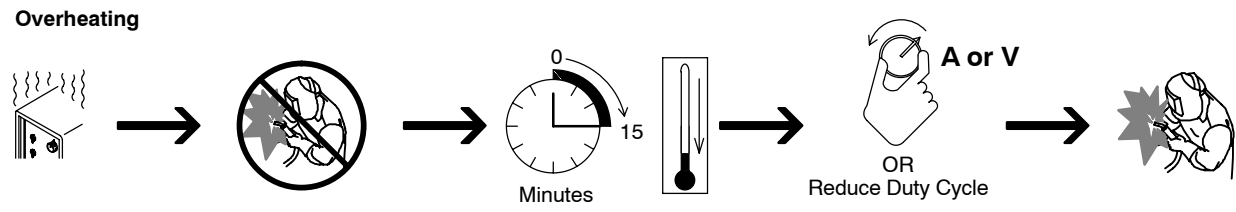

**▲ Exceeding duty cycle can damage unit and void warranty.**

Percent duty cycle = 1.7 times the number of 1 second (1000ms) loads/outputs per minute, without overheating. The one second load is the rated output.

If unit overheats, output stops. A HLP 3 message (see Section 8-4) is displayed, and cooling fan runs. Wait fifteen minutes for unit to cool. Reduce amperage or duty cycle before welding.

sduty1 5/95 / SA-207 877

# SECTION 4 – INSTALLATION - POWER SOURCE

## 4-1. Selecting a Location



### Dimensions And Weight

73 lb (33.1 kg)

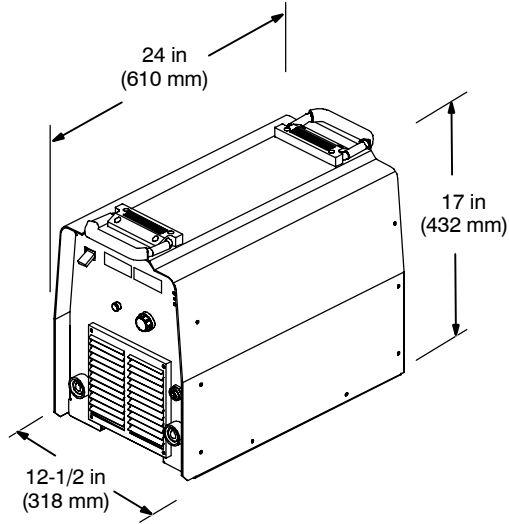

### Movement

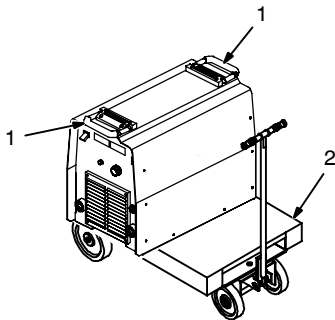

▲ Do not move or operate unit where it could tip.

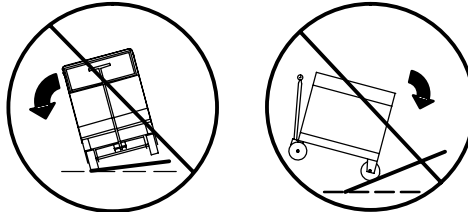

▲ Special installation may be required where gasoline or volatile liquids are present – see NEC Article 511 or CEC Section 20.

1 Lifting Handles

Use handles to lift unit.

2 Hand Cart

Use cart or similar device to move unit.

3 Rating Label

Use rating label to determine input power needs.

4 Line Disconnect Device

Locate unit near correct input power supply.

### Location

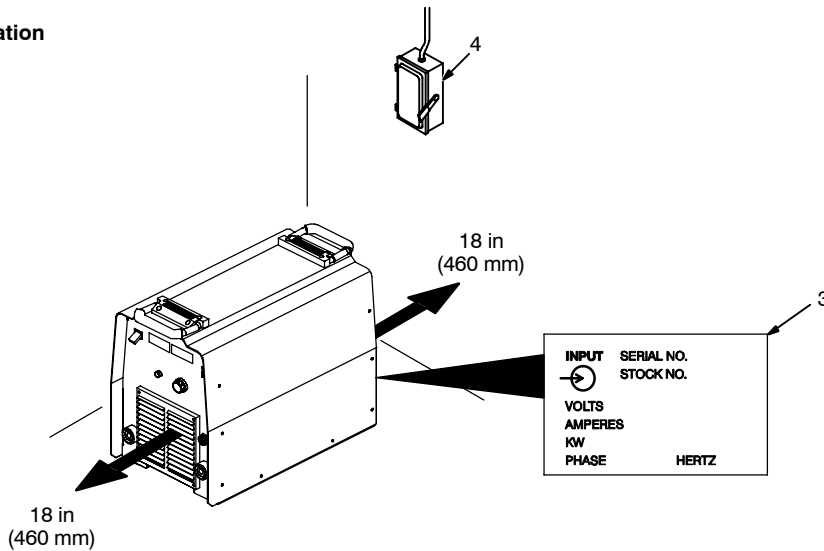



### 4-3. Weld Output Receptacles And Selecting Cable Sizes



**▲ ARC WELDING can cause Electromagnetic Interference.**

To reduce possible interference, keep weld cables as short as possible, close together, and down low, such as on the floor. Locate welding operation 100 meters from any sensitive electronic equipment. Be sure this welding machine is installed and grounded according to this manual. If interference still occurs, the user must take extra measures such as moving the welding machine, using shielded cables, using line filters, or shielding the work area.



**Weld Output Terminals**

- ▲ Turn off power before connecting to weld output terminals.
- ▲ Do not use worn, damaged, undersized, or poorly spliced cables.

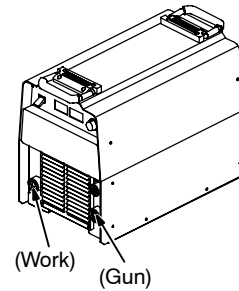

**Output Receptacles**

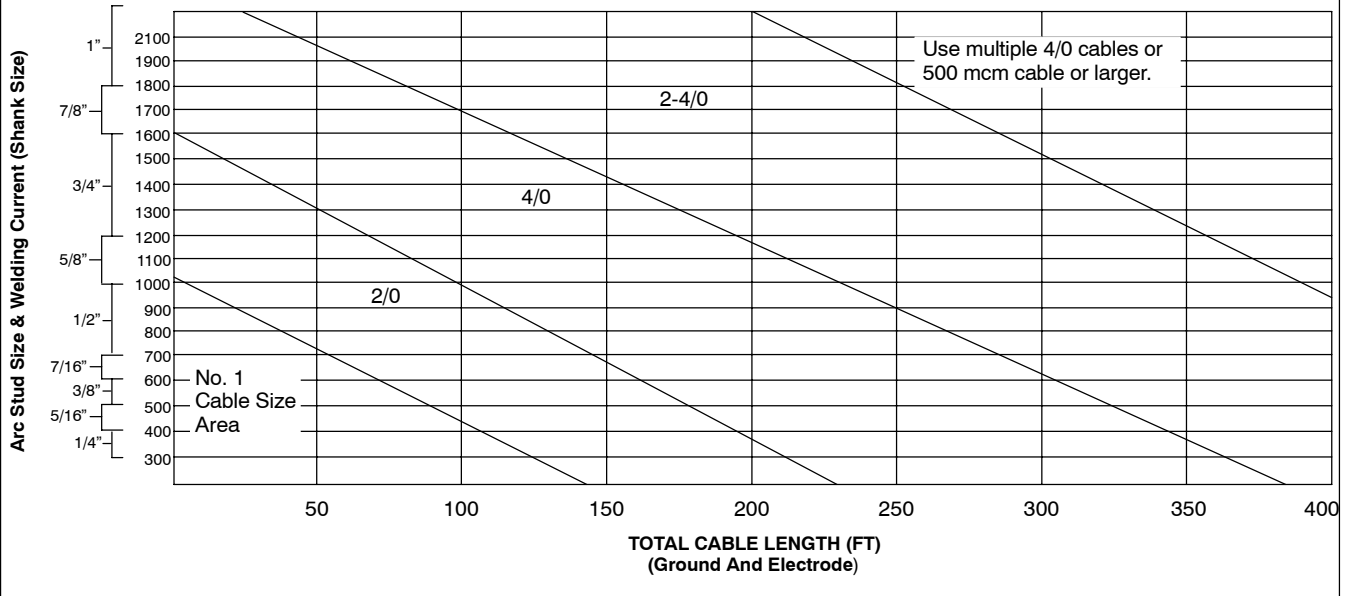

\* This chart is a general guideline and may not suit all applications. If cable overheating occurs (normally you can smell it), use next size larger cable.



## 4-4. Connecting 3-Phase Input Power

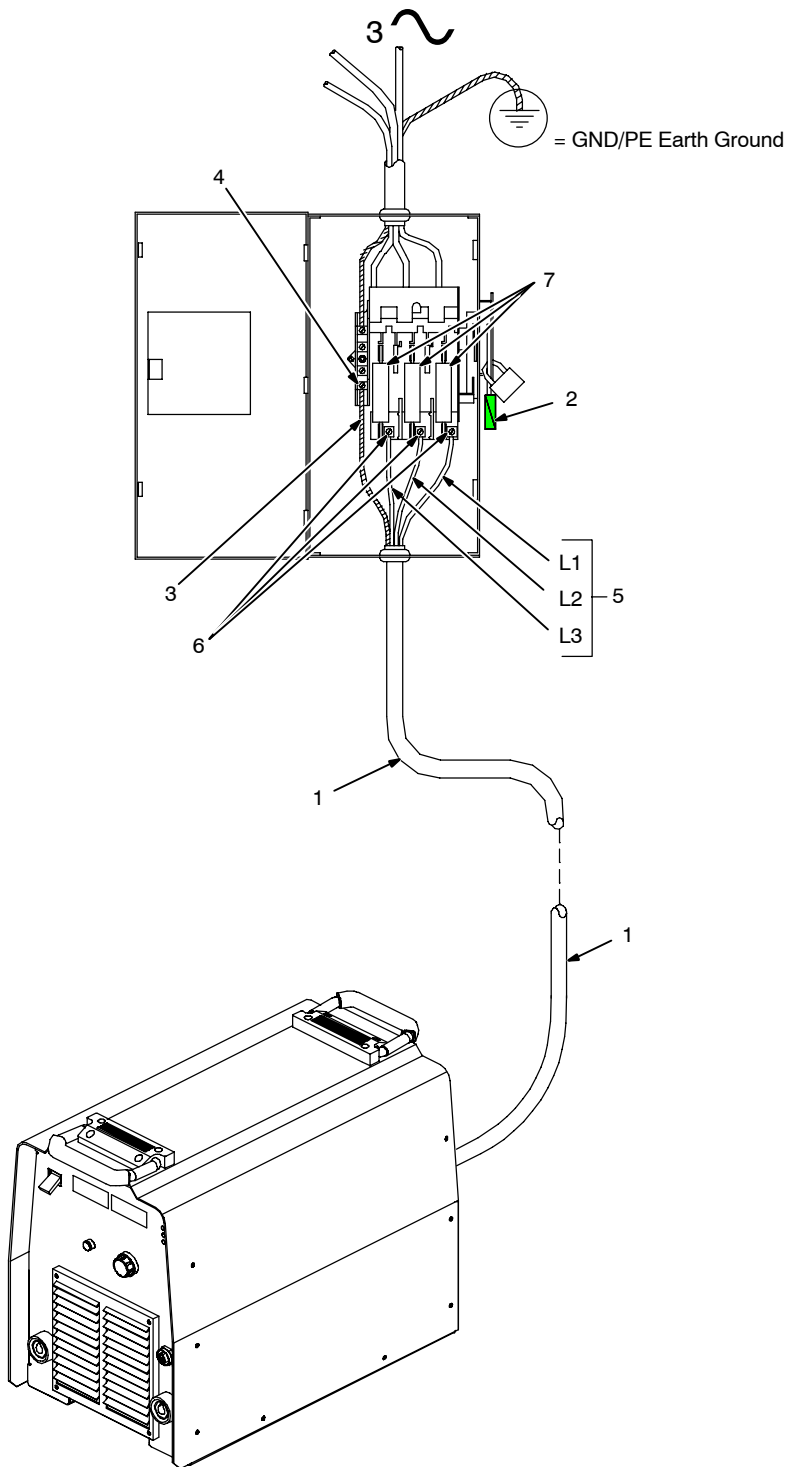

- ▲ Installation must meet all National and Local Codes – have only qualified persons make this installation.
- ▲ Disconnect and lockout/tagout input power before connecting input conductors from unit.
- ▲ Always connect green or green/yellow conductor to supply grounding terminal first, and never to a line terminal.

 The Auto-Link circuitry in this unit automatically adapts the power source to the primary voltage being applied. Check input voltage available at site. This unit can be connected to any input power between 480 or 575 VAC without removing cover to relink the power source.

- 1 Input Power Cord.
- 2 Disconnect Device (switch shown in the OFF position)
- 3 Green Or Green/Yellow Grounding Conductor
- 4 Disconnect Device Grounding Terminal
- 5 Input Conductors (L1, L2 And L3)
- 6 Disconnect Device Line Terminals
- 7 Overcurrent Protection

Connect green or green/yellow grounding conductor to disconnect device grounding terminal first.

Connect input conductors L1, L2, and L3 to disconnect device line terminals.

7 Overcurrent Protection

Select type and size of overcurrent protection using Section 4-2 (fused disconnect switch shown).

Close and secure door on disconnect device. Remove lockout/tagout device, and place switch in the On position.

Tools Needed:

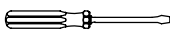

## 4-5. Circuit Breaker

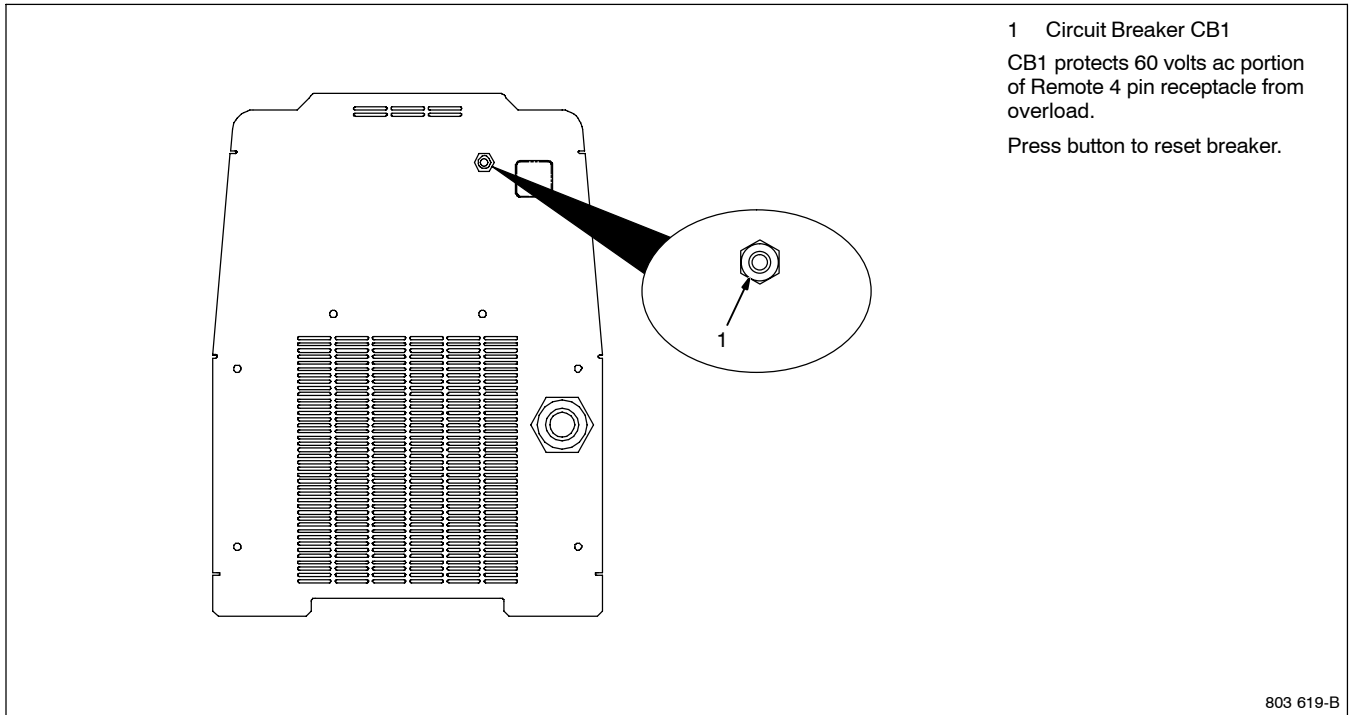

## 4-6. 4 Pin Receptacle Information

	CONTROL	Socket	Socket Information
GUN CONTROL		1	Output to control of gun solenoid; 90 volts dc.
		2	
⚡ OUTPUT (CONTACTOR)		3	Contact closure between 3 and 4 initiates weld cycle.
		4	

## 4-7. Rack Mounting

This unit is capable of being rack mounted (Contact your distributor).

# SECTION 5 – INSTALLATION - STUD GUN

## 5-1. Chuck Installation



 Do not hammer or beat chuck into position.

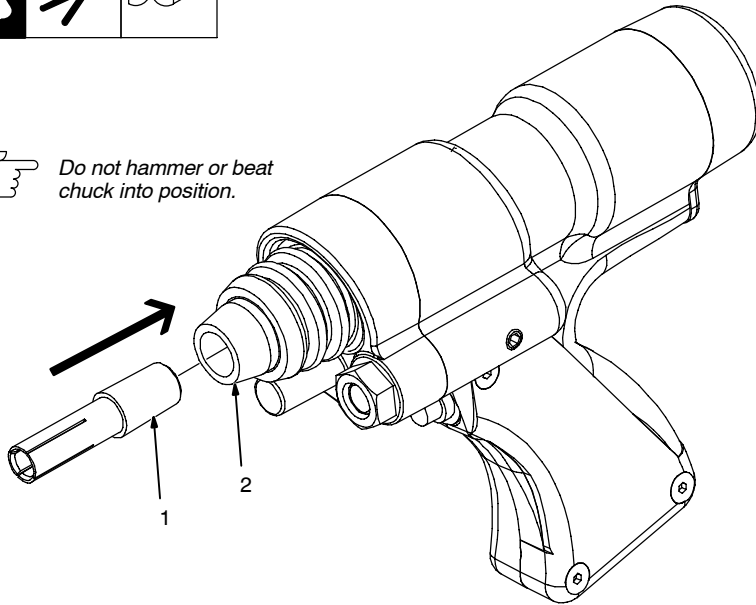

▲ Disconnect gun from power source before installing or removing components.

- 1 Chuck
- 2 Chuck Adapter

To install chuck, align chuck in front of chuck adapter. Tap firmly on the end of chuck to seat chuck into adapter. Not necessary to pound on the end of the chuck. This will damage the chuck.

 There is a unique chuck for every diameter of stud. Rectangular and other special shape studs may require specialized chucks. There is also a depth stop inside of the chuck. The depth stop should be adjusted so that you are retaining a good portion of the stud you are setting up to weld. Typically, this is one third to one half of the length of the stud being welded.

## 5-2. Chuck Removal

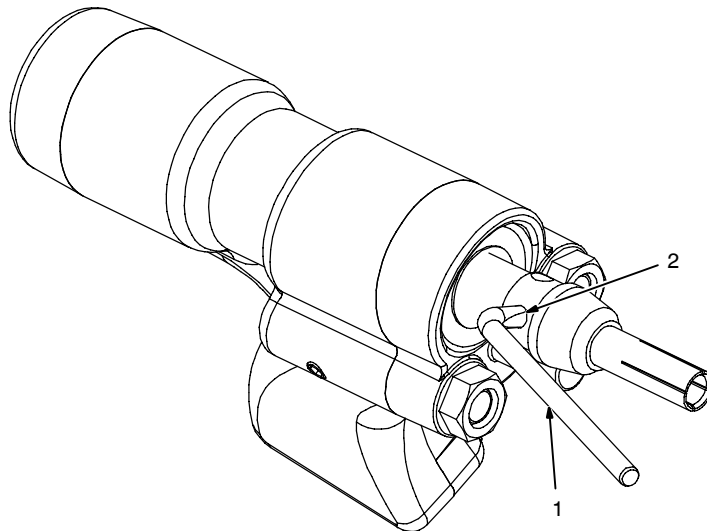

- 1 Chuck Key
- 2 Hole - Chuck Adapter

To remove chuck, insert short, tapered end of chuck ejector key into one of the holes in the side of the chuck adapter. It may be necessary to move the rubber bellows to see the holes in the side of the chuck adapter.

Rotate chuck key clockwise or counter clockwise and the chuck will pop out of the chuck adapter.

 Chuck is held into the chuck adaptor with a #2 morse taper.

### 5-3. Foot and Leg Setup

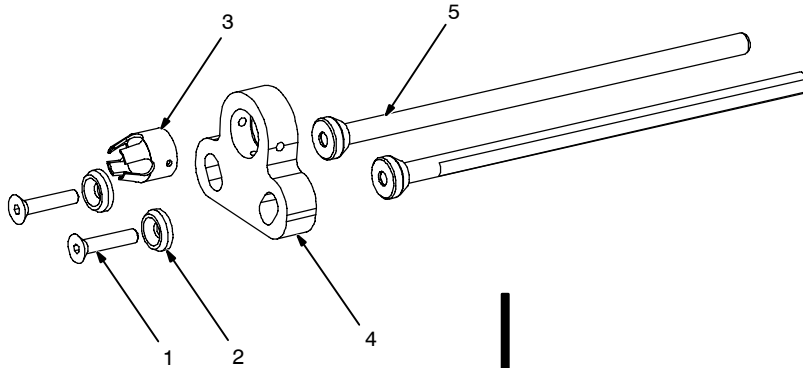

Make sure flat side of legs face outside of gun body to ensure alignment with set screws.

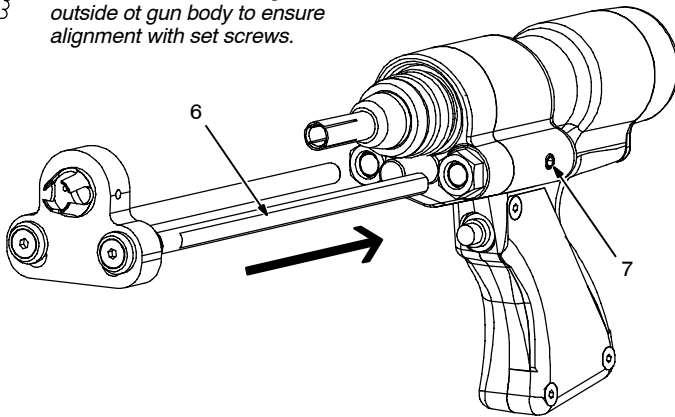

#### Foot Installation

- 1 Leg Screw
- 2 Leg Washer
- 3 Ferrule Grip
- 4 Foot
- 5 Leg

The foot is available in 3 different sizes (small, medium, and large) and 2 different configurations (closed and split). Typically, a split foot is only used when welding headed anchors and shear connectors.

Foot Size	Stud Range	Part #
Small	Up to 1/2 in.	219670
Medium	5/8 to 3/4 in.	219671

The foot is installed on the ends of the legs. Unscrew the flat head screws from the ends of the legs. Place the trim washers on the flat head screws and place the screws through the adjustment slots in the foot. Reattach the screws to the legs.

#### Leg Installation

- 6 Flat Side of Leg
- 7 Leg Set Screw

Insert legs into leg retainers. Line up the flat side of the legs with set screws. Tighten set screws securely.

### 5-4. Ferrule Grip / Spark Shield Removal and Installation

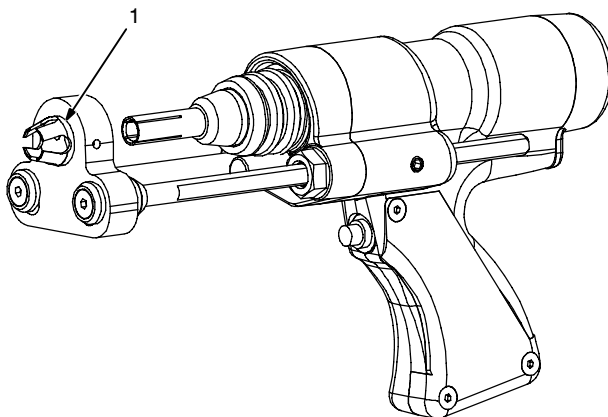

- 1 Ferrule Grip

There are 3 set screws that retain the ferrule grip or spark shield in the foot. Loosen all 3 set screws.

Push the ferrule grip or spark shield into the foot. Press ferrule grip firmly into the foot so it seats against the back stop. Line up the 2 side holes in the ferrule grip with set screws in the foot. Tighten set screws securely.

*If a spark shield is being used, it is not necessary to align the spark shield with the set screws in the foot.*

## 5-5. Foot Alignment

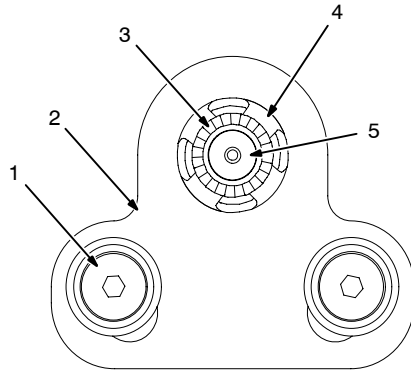

- 1 Leg Screw
- 2 Foot
- 3 Ferrule
- 4 Ferrule Grip
- 5 Stud

**ⓘ** Alignment of the foot is very important, if the foot is not aligned properly it can create bad welds in the form of hang-ups.

Place a stud into the chuck and a ferrule into the ferrule grip. The stud should sit perfectly in the center of the ferrule. If not, loosen the flat head screws on the legs holding the foot.

Position the foot so the stud is perfectly aligned in the ferrule. Retighten the flat head screws.

## 5-6. Connecting Stud Gun and Work Clamp to Power Source

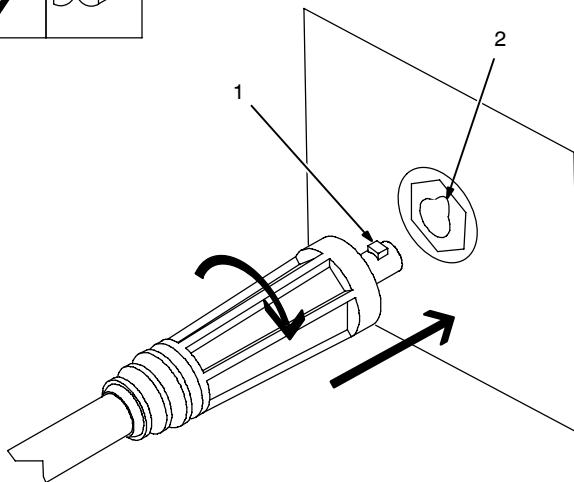

Perform the following procedures when connecting stud gun to power source:

- Connect weld cable
- Connect control cable

**ⓘ** Use the same instructions provided if connecting to an extension cable.

### Connecting Weld Cable and Work Ground Cable

- 1 Flat
- 2 Keyway

To connect to receptacle, align keyway, insert connector, and turn clockwise (approximately 1/2 turn).

Connect stud gun to black output terminal labeled gun.

Connect work cable to black output terminal labeled work.

### Connecting Control Cable

- 3 Key
- 4 Keyway

Align key in end of control cable with keyway inside connector on front of power supply. Push the connectors together. Turn retaining nut on control cable clockwise. When nut is snug the connection is complete.

To remove, unscrew connector counter clockwise.

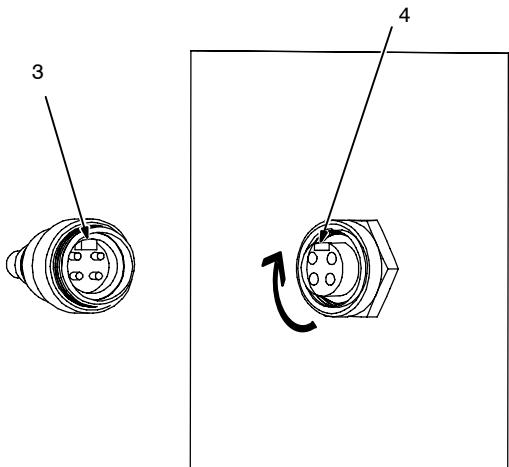



## 5-8. Adjusting Stud Lift



Lift Adjustment Table

1/16 in (1.6 mm) lift for studs up to 5/16 (7.9 mm) diameter
3/32 in (2.4 mm) lift for studs over 5/16 (7.9 mm) to 1/2 in (13 mm) diameter
1/8 in (3.2 mm) lift for studs over 1/2 (13 mm) diameter

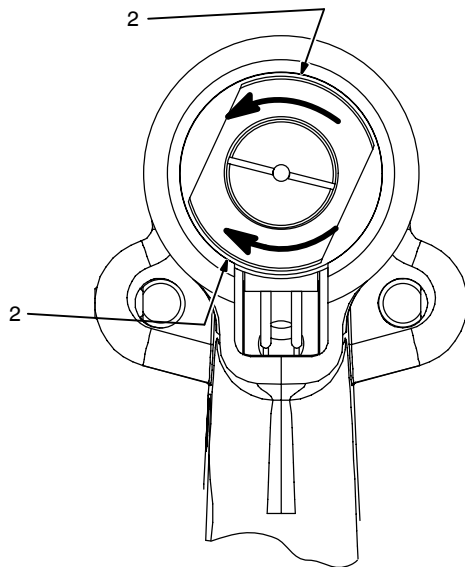
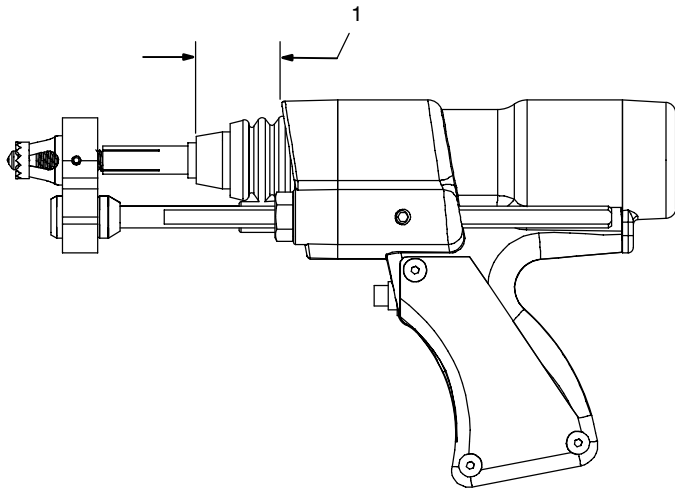

The lift controls the arc length and is a factor in controlling the heat of the welding process.

Lift should be set at 3/32 or .094 in (2.5 mm).

### Measuring Lift

▲ **For safety from accidental activation, always disconnect the weld cable from the power source before making any stud gun adjustments or performing any service on the stud gun.**

#### 1 Stud Lift Measurement

To measure stud lift, hold a scale against some fixed part of the tool. The front cover or foot will work well. Press the trigger so the tool activates the lift mechanism. Now measure again. The lift is the difference between the two measurements.

### Adjusting Lift

#### 2 Location of Core Set Screws

To adjust lift, remove the slotted screw holding the rear cap in place. Remove rear cap. Loosen the nylon tipped set screw that holds the adjustable core in place. To increase lift, turn the adjustable core screw counter clockwise. To decrease lift, turn the adjustable core screw clockwise. Each half turn equals .025 in (0.6 mm).

Once lift is set, retighten nylon tipped set screw to keep the adjustable core in place.

Install rear cap and tighten cap screw.

☞ *Keep cap in place to prevent dirt from entering the stud gun mechanism*

# SECTION 6 – OPERATION - POWER SOURCE

## 6-1. Front Panel Controls

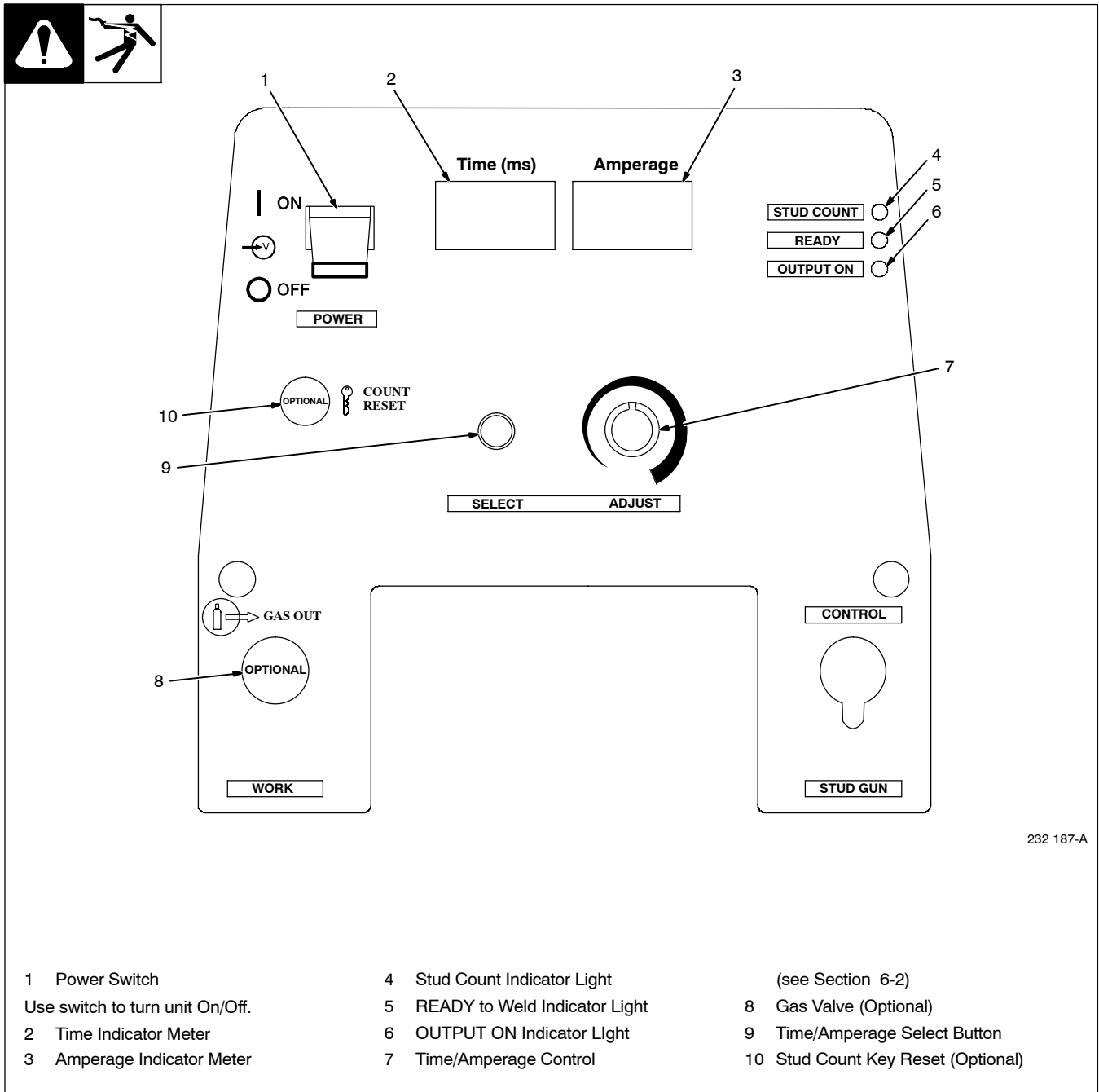





## 6-2. Time/Amperage Control

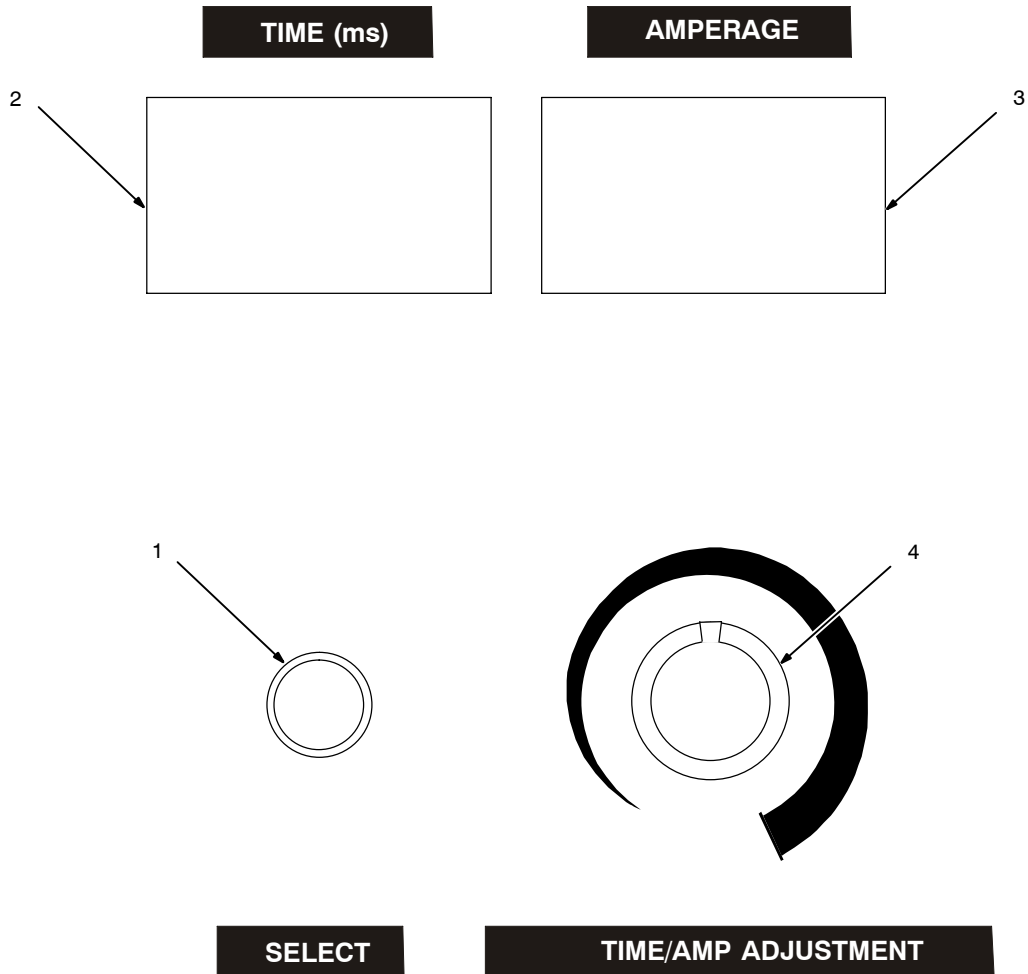

Ref. 232 187-A

- 1 Time/Amperage Select Button  
Depress button to select Time/Amperage control.
- 2 Time Meter
- 3 Amperage Meter

- 4 Time/Amp Adjustment Control  
Rotate knob clockwise to increase time/amperage
- Time - (5-1000 milliseconds)
  - Amperage - (50-1000 amps)

Rotate knob counterclockwise to decrease time/amperage.

 The active display will be lit and adjustable. The inactive display will turn off.

Ready

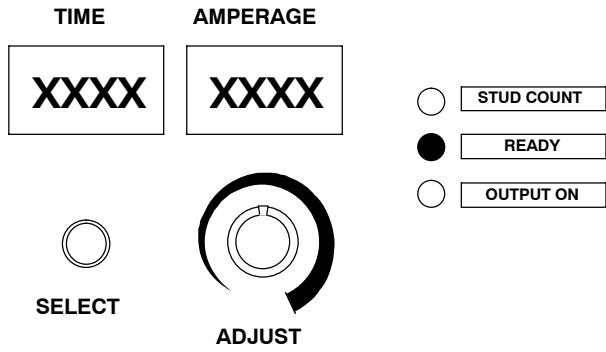

**Amperage Adjustment** - Push select button once. Returns to "Ready" display in six seconds after adjustment.

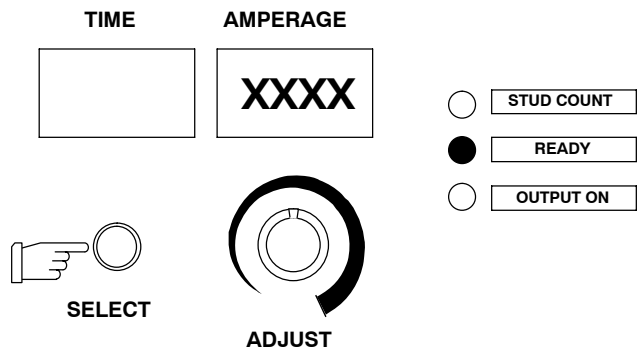

**Time Adjustment** - Push select button twice. Returns to "Ready" display in six seconds after adjustment.

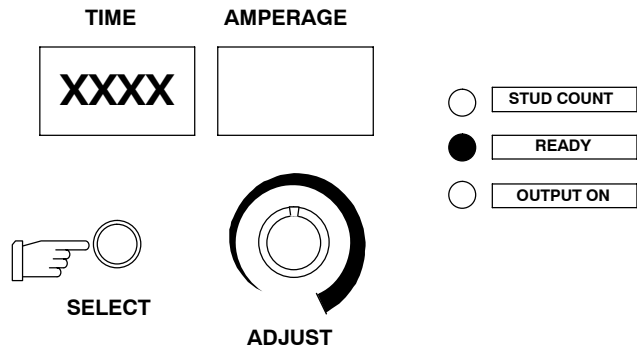

**Stud Count** - Push select button three times. Returns to "Ready" display in two seconds.

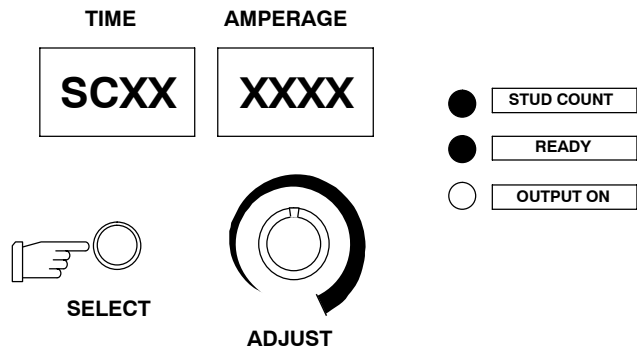

# SECTION 7 – OPERATION - STUD GUN

## 7-1. Stud Gun Tool Functions

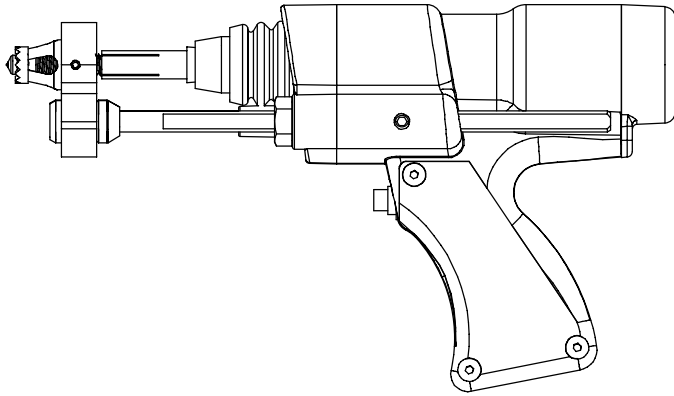

▲ **Disconnect gun from power source before installing or removing components.**

**The stud gun automates the stud welding process.**

Several key functions are:

- Holds the ferrule, spark shield or gas delivery system
- Holds the stud
- Strikes the arc
- Establishes the arc length (lift distance)
- Thru the power source, the gun controls the arc time
- Controls rate of plunge of the stud into the base metal

## 7-2. Stud Welding Procedures

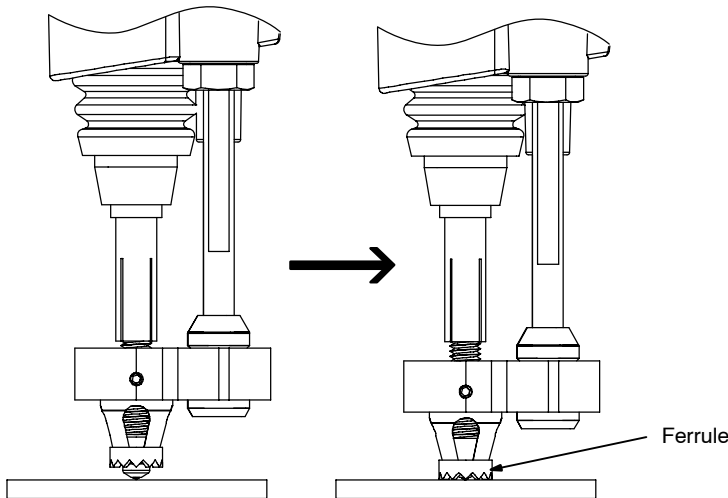

**Position tool against work**

**Press tool towards work until ferrule is against work**

☞ *Before welding it is important to review the set up. Correct set up will produce the best welding results. Approximately 95% of all stud welding problems are due to improper gun set up or power settings.*

**Welding Procedures:**

- Place stud to be welded into weld chuck.
- Insert a ferrule into the ferrule grip (this step is not necessary if using a spark shield)
- Position end of stud in location to be welded.
- Press gun downward so the ferrule is sitting on the base metal.
- Pull trigger to begin weld sequence.
- Hold gun still during the arcing process.
- After weld is complete, continue to hold the gun still for 1 second to allow the molten metal to solidify.
- Remove the gun from the welded stud. Be sure and pull the gun straight off of the welded stud to prevent damage to the weld chuck.
- Break away the ferrule and inspect the weld. (Only applies if ferrule was used)

### 7-3. Welding Sequence

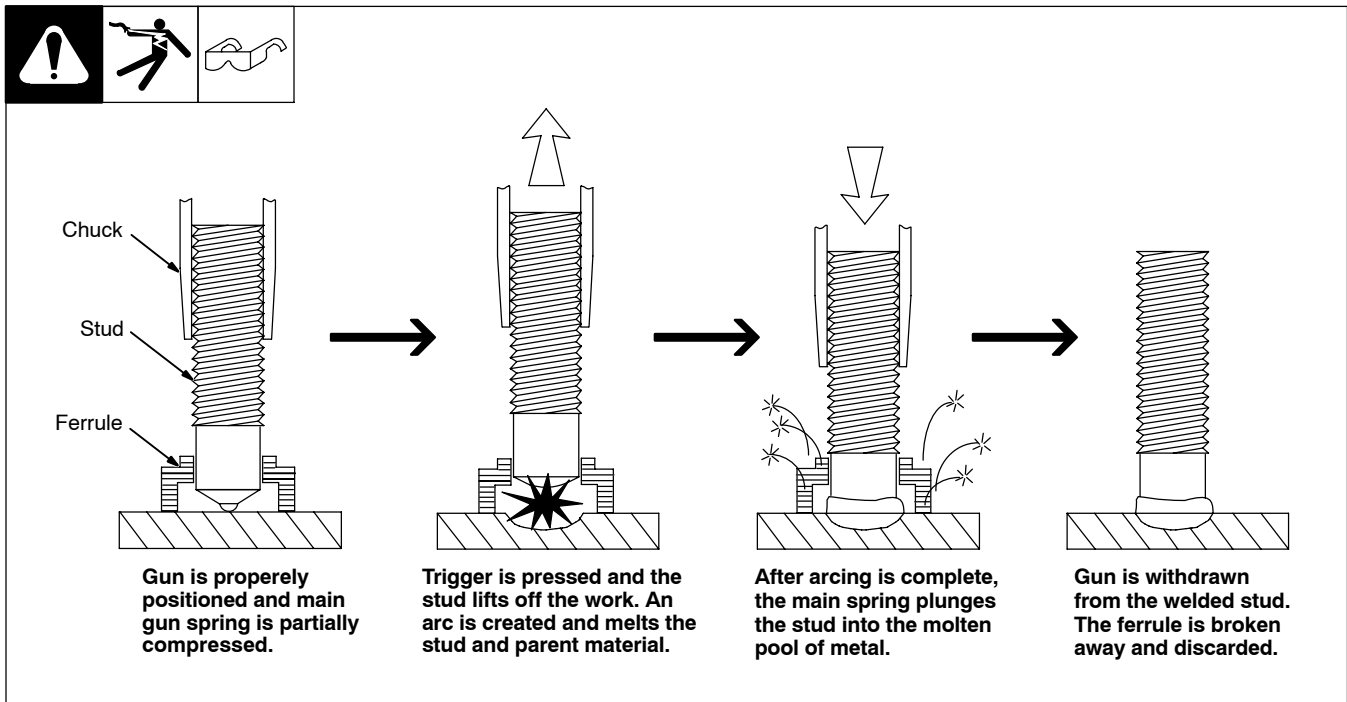

### 7-4. Recommended Settings

STANDARD TABLE			METRIC TABLE		
Stud Size	Current	Time	Stud Size	Current	Time
1/4 Inch	300 Amps	.220 Seconds	6 mm	350 Amps	.250 Seconds
5/16 Inch	410 Amps	.300 Seconds	8 mm	420 Amps	.310 Seconds
3/8 Inch	520 Amps	.360 Seconds	10 mm	580 Amps	.430 Seconds
1/2 Inch	750 Amps	.450 Seconds	12 mm	720 Amps	.500 Seconds
5/8 Inch	980 Amps	.730 Seconds	14 mm	880 Amps	.590 Seconds
3/4 Inch	1325 Amps	.750 Seconds	16 mm	1040 Amps	.660 Seconds
7/8 Inch	1680 Amps	.830 Seconds	20 mm	1440 Amps	.780 Seconds
1 Inch	2000 Amps	.870 Seconds	24 mm	1900 Amps	.850 Seconds

The recommended settings are provided as initial settings. Settings may vary per specifications of application. Material surface condition along with lift and plunge adjustments will vary exact settings.

- Material surface at weld location should be free of dirt, rust and paint.
- Typical adjustments for lift is 3/32 in and plunge is 1/8 in (see Sections 5-7 and 5-8).
- Adjust recommended settings as needed.

# SECTION 8 – MAINTENANCE & TROUBLESHOOTING

## 8-1. Routine Maintenance

		▲ Disconnect power before maintaining.		Maintain more often during severe conditions.
<b>3 Months</b>				
		Replace Damaged Or Unreadable Labels		Repair Or Replace Cracked Cables
				Replace Cracked Stud Gun Body
				Repair Or Replace Cracked Cables And Cords
				Clean And Tighten Weld Connections
<b>6 Months</b>				
				Blow Out Inside

## 8-2. Blowing Out Inside Of Unit

		▲ Do not remove case when blowing out inside of unit. To blow out unit, direct airflow through front and back louvers as shown.
--	--	--

803 618-B



## 8-3. Maintenance Procedures for Stud Gun

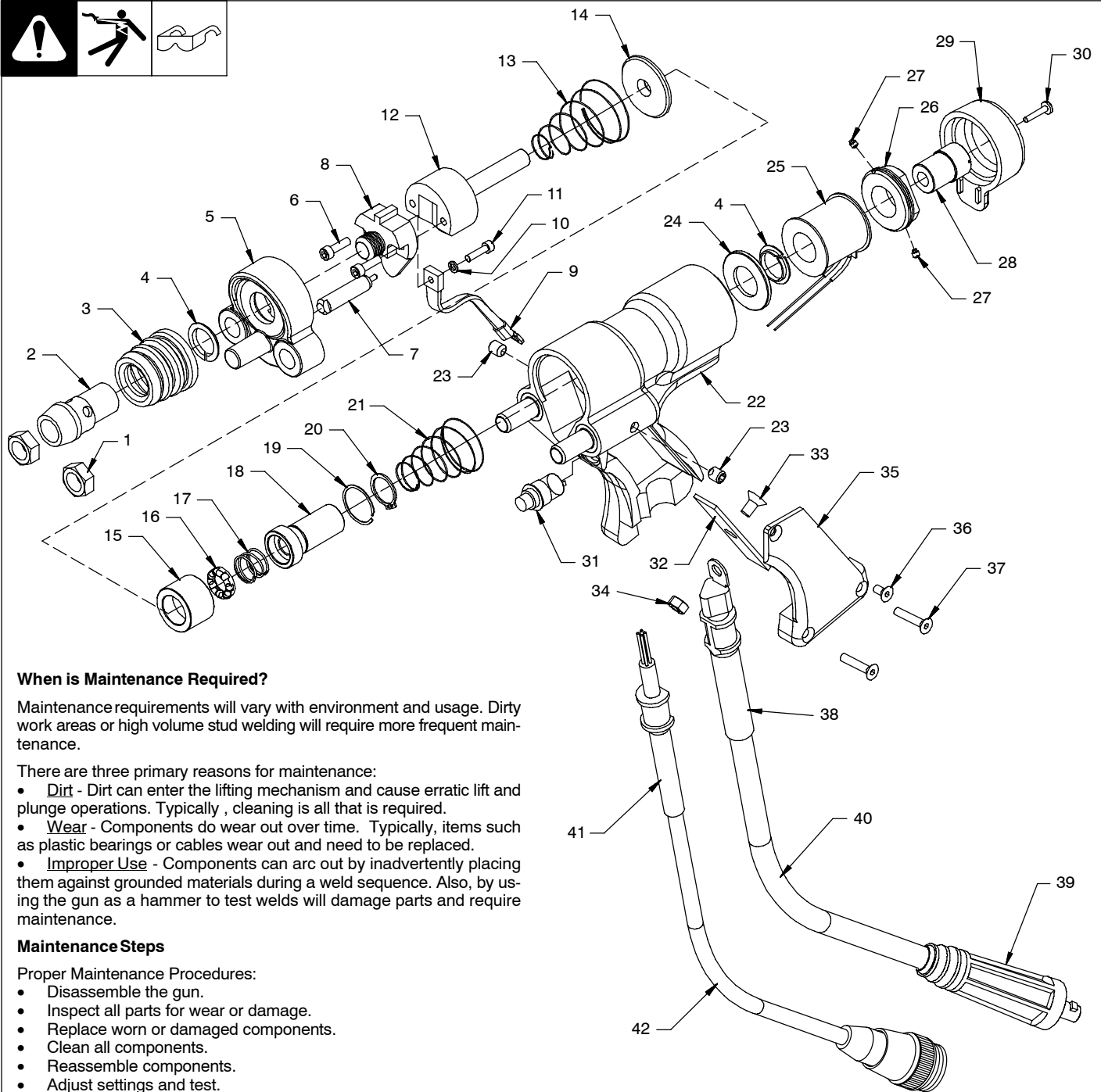

### When is Maintenance Required?

Maintenance requirements will vary with environment and usage. Dirty work areas or high volume stud welding will require more frequent maintenance.

There are three primary reasons for maintenance:

- **Dirt** - Dirt can enter the lifting mechanism and cause erratic lift and plunge operations. Typically, cleaning is all that is required.
- **Wear** - Components do wear out over time. Typically, items such as plastic bearings or cables wear out and need to be replaced.
- **Improper Use** - Components can arc out by inadvertently placing them against grounded materials during a weld sequence. Also, by using the gun as a hammer to test welds will damage parts and require maintenance.

### Maintenance Steps

Proper Maintenance Procedures:

- Disassemble the gun.
- Inspect all parts for wear or damage.
- Replace worn or damaged components.
- Clean all components.
- Reassemble components.
- Adjust settings and test.

### Disassembly / Assembly Procedures:

- ▲ **To prevent accidental activation disconnect the gun from the power source before adjusting or servicing the gun.**

☞ Remove all accessories from gun before servicing.

☞ Items referenced ( ) will correspond with list items.

- 1 **Legs**: Loosen set screws (23) and pull legs (not shown) straight out. Inspect legs for damage and straightness, replace if necessary.
- 2 **Chuck (Not Shown)**: Insert chuck key into chuck adapter and turn key 180 degrees. Inspect chuck for damage. If taper on chuck appear worn out replace chuck.
- 3 **Dust Bellows (3)**: Remove dust bellows by sliding over end of chuck adapter. The bellows prevent contaminants from entering the internal mechanisms of the gun. If bellows has holes or is torn, replace.



- 4 **Chuck Adapter** (2): Unscrew chuck adapter counter clockwise from cable clamp adapter. Important that chuck adapter is tight on cable clamp adapter to form a tight connection. An effective way of removing the adapter is to insert a round rod through two of the chuck eject holes.  
Replace chuck adapter if inside surface or threads are pitted or damaged.
- 5 **Front Cover Nuts** (1): The front cover is held on with two nuts. Use a 3/4 inch wrench to remove them. Inspect the plastic bearing (4) for damage or excessive wear.
- 6 **Front Cover** (5): If gun is equipped with a plunge dampener it is located in the front cover. Inspect front cover for cracks and replace if cracked. The front cover prevents dirt from entering the internal mechanism and maintains alignment of internal components.
- 7 **Plunge Dampener** (7): The dampener is inside the front cover. It pulls straight out and pushes straight back in. When the plunge dampener is activated by a finger it should offer continuous resistance over the entire range of travel. The plunger should then return, by itself, to full extension. If this is not the case the dampener needs to be replaced.
- 8 **Cable Clamp Adapter** (8): Remove two #10-32 x 5/8 socket head cap screws (6) from cable clamp adapter. The cable clamp adapter will separate from the lifting rod. Maneuver the cable clamp adapter forward between the leg inserts. Remove the #8-32 x 1/2 cap screw (11) from the back of the cable clamp adapter (8).  
Inspect threads on cable clamp adapter. If threads are damaged replace cable clamp adapter. This item transfers all the weld current. If there is damage to the threads, arcing will continue and potentially fuse all the components together.
- 9 **Lifting Mechanism**: The lifting mechanism consists of the lifting rod (12), main spring (13), lift release (14), moveable core (15-20) and core return spring (21). To disassemble, press the lift release ring tight against the moveable core and pull the lifting rod out of the assembly. All components listed above, will come apart.
- 10 **Lifting Rod** (12): Inspect lifting rod for wear or damage. The brass inserts should show no signs of loosening. The steel shaft should not have any nicks on it. Run a finger over the shaft. If you can feel grooves from the lifting bearing then the lifting rod is worn out. Typically the lifting rod and lift bearing should be replaced as a set. When reassembling, the shaft should have a light film of grease (a lithium based grease) applied.
- 11 **Disassembly of Moveable Core** (15 - 20): Remove snap ring (20) from shaft (18) of core assembly. The snap ring acts as a spring seat and is important to maintain proper spring tension. Where the core assembles into the bearing housing is another retaining ring (19). This retaining ring can be removed with a small flat bladed screw driver. After removing the second retaining ring the bearing housing (15) will separate from the core shaft. The lift bearing (16) and the lift bearing spring (17) can now be removed.  
When reassembling the lift bearing cage must oriented toward the lift bearing spring. Put a light film of grease (such as a lithium based grease) over the lift bearing and the lift bearing spring.
- 12 **Handle Covers** (35): Remove 3 flat head screws (36 - 37) that retain the handle cover. Inspect handle cover for breakage.
- 13 **Weld Cable** (40): The weld cable can lift out of the gun body. Be careful unthreading the internal weld cable (9) from inside the body. The internal and external weld cables can be unscrewed from the weld cable anchor plate (32). Note the orientation of the weld cable anchor plate. The radius corner goes toward the top of the body.  
Inspect the internal weld cable for frayed or broken wires. If starting to fray, the internal cable should be replaced.  
Inspect weld cable for fraying. Also inspect strain relief (38) for tears. Inspect cable jacketing for breaks, cuts or tears. If cable shows signs of damage or wear it should be replaced. In addition, inspect the weld-lok connector (39). If pitted or damaged, replace. Inspect weld cable to camlok joint to ensure there is no fraying of the weld cable.
- 14 **Control Cable** (42) (if desired): The control cable is removed by cutting the wires by the splice connectors. Inspect the control cable for damage. This includes the strain relief (41) and the insulating jacketing. If damaged, replace the control cable.  
When reinstalling the control cable, there are typically two different color schemes.  
**Scheme one:** Black and White wires connect to the trigger - Blue and Brown Wires connect to the coil  
**Scheme two:** Black and White wires connect to the trigger - Red and Green wires connect to the coil.  
Make sure all crimp connections are tight and there is no opportunity for electrical shorting.
- 15 **Trigger Switch** (31): The trigger switch is a screw in style. Grabbing it can be difficult. A 1/2" collet is the ideal removal tool. Use an ohm meter to check trigger functionality.
- 16 **Rear Cap** (29): Unscrew and remove. The rear cap prevents dirt and other contaminants from entering into the gun mechanism.  
 *Do not use rear of gun as a hammer to check quality of stud weld for this will damage the rear cap.*
- 17 **Adjustable Core** (28): Loosen nylon tipped set screw (27) in rear coil yoke which holds the adjustable core. Completely unscrew and remove adjustable core.
- 18 **Rear Coil Yoke** (26): Loosen the nylon tipped set screw retaining the rear coil yoke. To perform this the hex key will have to go into the opening on an angle to reach the set screw. Once the retaining screw is loosened use a large wrench to unscrew the rear coil yoke.
- 19 **Coil** (25): Coil wires (black and red or green and red inside the gun handle) must be cut prior to coil removal. Cut wires inside the handle. After coil wires are free, the coil can be pulled straight out the rear of the gun. Coil condition - check to make sure there is no varnish odor (a sign of overheating), heavy discoloration (another sign of overheating) and verify coil resistance at 19 ohms +/- 1 ohm.
- 20 **Front Coil Yoke** (24): In front of the coil is the front coil yoke. This is a tight fit and may be difficult to remove. The front coil yoke contains a plastic bearing (4). This bearing should be inspected for wear or damage and replaced if necessary. During reassembly, make sure the bearing flange is seated in the counterbore on the front coil yoke. When putting the front coil yoke back into the coil can, make sure the bearing flange is facing rear of gun.

Tools Needed:

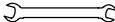
 3/4 in

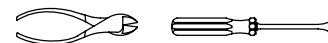

## 8-4. Troubleshooting Help Aids

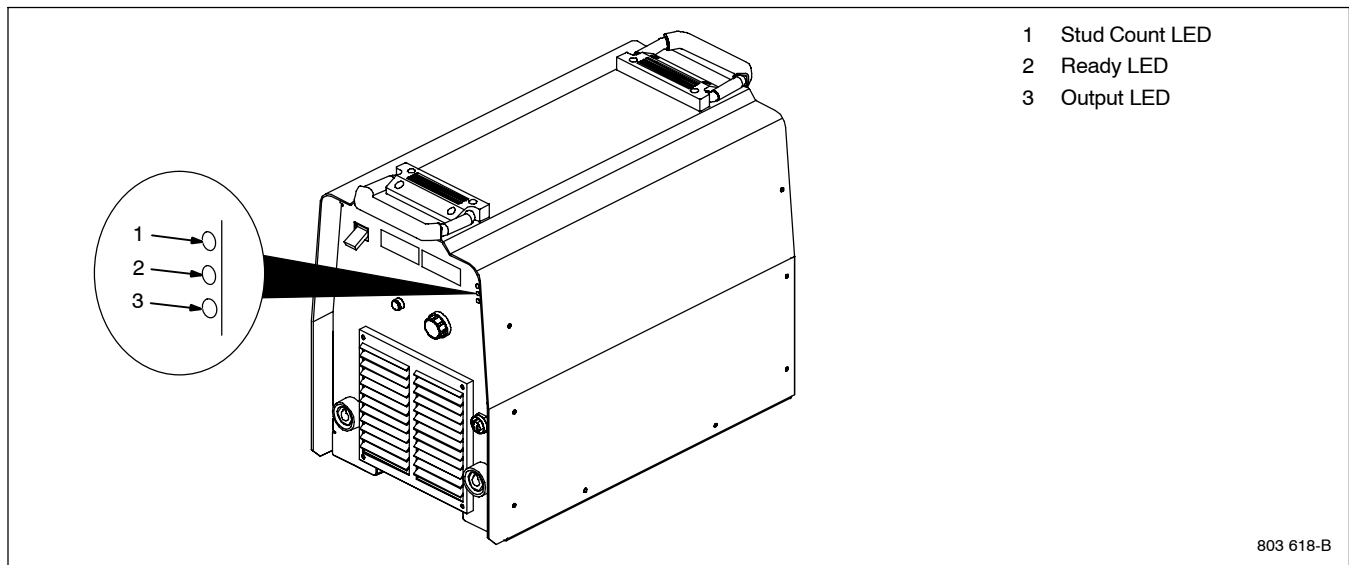

Front Panel Error Indication	Ready LED Status	Possible Symptom	Remedy
Normal/None	On	No problem	N/A
HELP 1	Off	Malfunction in the primary power circuit.	Contact a factory authorized service agent.
HELP 2	Off	Malfunction in the thermal protections circuitry.	Contact a factory authorized service agent.
HELP 3	Off	Unit has overheated.	Unit has shut down to allow the fan to cool it (See Section 3-2). Operation will continue when the unit has cooled.
HELP 4	Off	Trigger circuit is closed when unit was powered on.	Open trigger circuit and cycle power.
HELP 5	Off	The unit has sustained an Open Circuit Voltage for more than 10 seconds.	Cycle power. Apply a welding load. If problem persists, contact a factory authorized service agent.
HELP 6	Off	Input voltage is either under/low voltage or high/over voltage.  DC bus voltage imbalance.	Unit has automatically shut down. Operation will continue when input voltage is within an acceptable limit. Have an electrician check the input voltage.  If input voltage is correct, contact authorized factory service agent.

## 8-5. Troubleshooting - Power Source

Trouble	Remedy
No weld output; unit completely inoperative.	Place line disconnect switch in On position (see Section 4-2).
	Check and replace line fuse, if necessary, or reset circuit breaker (see Section 4-2).
	Check for proper input power connections (see Section 4-2).
No weld output.	Input voltage outside acceptable range of variation (see Section 4-2).
	Unit overheated. Allow unit to cool with fan On (see Section 3-2).
Erratic or improper weld output.	Use proper size and type of weld cable (see Section 4-3).
	Clean and tighten all weld connections.

## 8-6. Troubleshooting - Stud Gun

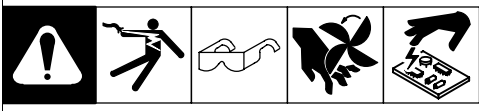
	
Trouble	Remedy
Hang up - Stud looks like it's sitting on a pedestal with an hour glass shape	Check alignment of the foot.
	Service the gun to ensure lift/release actions are functioning properly.
Undercutting or lack of fillet	Too little plunge. Increase amount of stud extending past end of ferrule or spark shield.
	Too little weld time or current. Check Section 7 for base line power recommendations.
Splatter or BB'S emitting from the weld zone.	Too much plunge. Decrease amount of stud extending past end of ferrule or spark shield.
	Dampener Required. If you have a dampener the dampener may have worn out and need replacement. See optional equipment in Section 12.
	Too much Current or Time. Check Section 7 for base line power recommendations.
Stud breaks off and weld zone looks "crystalized"	Not enough weld current or time. Check Section 7 for base line power recommendations.
Bubbles in weld fillet	If you are attempting short arc you may not be able to eliminate this condition. To improve this situation shorten time and increase current. If the results continue to be unsatisfactory then you may need to add a shielding gas.
	Check gas flow/type of shielding gas.
	If using flux loaded studs, check to make sure there is a flux load present in the end of the stud.
No lift	Check gun coil connections.
	Check for gun coil short or open. There should be 19 ohms of resistance in the gun coil.
	Check adjustable core and make sure it is not bottomed out (turned into far clockwise).
	Check trigger circuit for opens and shorts.
Short stud and cant get enough to extend past the ferrule	Adjust the internal stop in the chuck.
Arc Extinguishes, or just get a tiny arc but no weld	Too much lift. Review set up procedures in Section 5.
	Check ground path from the power source. All joints must be very tight.
No weld	Broken weld cable.
	Broken or bad ground cable/connection.
	Check gun lift.
Gun shaft does not move freely when compressed by hand	Dirt is binding the mechanism. Service gun
Gun spindle is sloppy and has allot of free play	Front bearing may be worn out or missing. Replace bearing.
	Front cover may be loose. Tighten nuts.

# Notes

## DECIMAL EQUIVALENTS

	$\frac{1}{64}$	.015625
	$\frac{1}{32}$	.03125
	$\frac{3}{64}$	.046875
$\frac{1}{16}$	$\frac{5}{64}$	.0625
	$\frac{7}{64}$	.078125
	$\frac{3}{32}$	.09375
	$\frac{9}{64}$	.109375
$\frac{1}{8}$	$\frac{11}{64}$	.125
	$\frac{13}{64}$	.140625
	$\frac{5}{32}$	.15625
	$\frac{15}{64}$	.171875
$\frac{3}{16}$	$\frac{17}{64}$	.1875
	$\frac{19}{64}$	.203125
	$\frac{7}{32}$	.21875
	$\frac{21}{64}$	.234375
$\frac{1}{4}$	$\frac{23}{64}$	.25
	$\frac{25}{64}$	.265625
	$\frac{9}{32}$	.28125
	$\frac{27}{64}$	.296875
$\frac{5}{16}$	$\frac{29}{64}$	.3125
	$\frac{31}{64}$	.328125
	$\frac{11}{32}$	.34375
	$\frac{33}{64}$	.359375
$\frac{3}{8}$	$\frac{35}{64}$	.375
	$\frac{37}{64}$	.390625
	$\frac{13}{32}$	.40625
	$\frac{39}{64}$	.421875
$\frac{7}{16}$	$\frac{41}{64}$	.4375
	$\frac{43}{64}$	.453125
	$\frac{15}{32}$	.46875
	$\frac{45}{64}$	.484375
$\frac{1}{2}$	$\frac{47}{64}$	.5
	$\frac{49}{64}$	.515625
	$\frac{17}{32}$	.53125
	$\frac{51}{64}$	.546875
$\frac{9}{16}$	$\frac{53}{64}$	.5625
	$\frac{55}{64}$	.578125
	$\frac{19}{32}$	.59375
	$\frac{57}{64}$	.609375
$\frac{5}{8}$	$\frac{59}{64}$	.625
	$\frac{61}{64}$	.640625
	$\frac{21}{32}$	.65625
	$\frac{63}{64}$	.671875
$\frac{11}{16}$	$\frac{65}{64}$	.6875
	$\frac{43}{64}$	.703125
	$\frac{23}{32}$	.71875
	$\frac{47}{64}$	.734375
$\frac{3}{4}$	$\frac{49}{64}$	.75
	$\frac{51}{64}$	.765625
	$\frac{25}{32}$	.78125
	$\frac{53}{64}$	.796875
$\frac{13}{16}$	$\frac{55}{64}$	.8125
	$\frac{57}{64}$	.828125
	$\frac{27}{32}$	.84375
	$\frac{59}{64}$	.859375
$\frac{7}{8}$	$\frac{61}{64}$	.875
	$\frac{63}{64}$	.890625
	$\frac{29}{32}$	.90625
	$\frac{65}{64}$	.921875
$\frac{15}{16}$	$\frac{67}{64}$	.9375
	$\frac{69}{64}$	.953125
	$\frac{31}{32}$	.96875
	$\frac{71}{64}$	.984375
$1$		1.

# SECTION 9 - ELECTRICAL DIAGRAMS

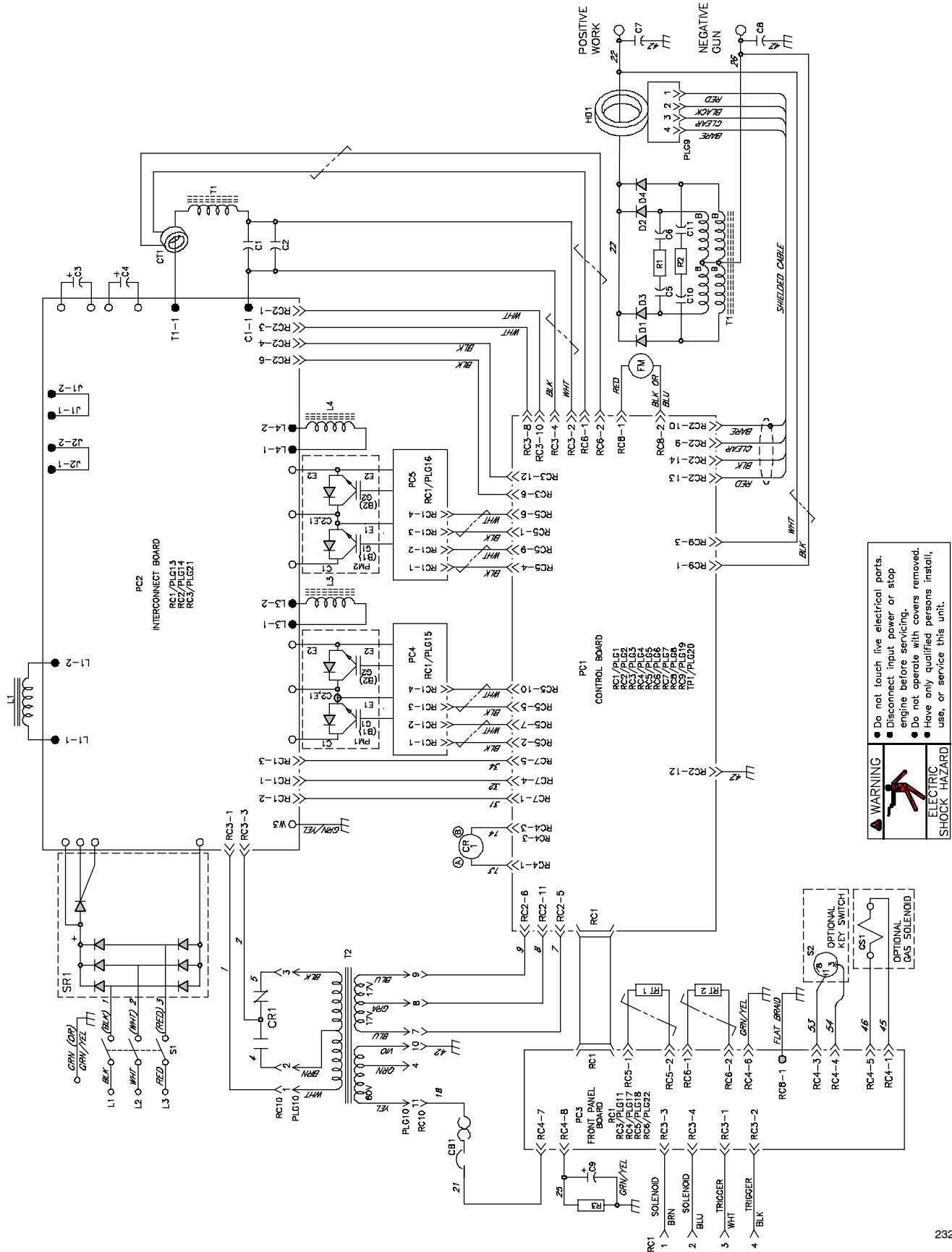

**WARNING**

- Do not touch live electrical parts.
- Disconnect input power or stop engine before servicing.
- Do not operate with covers removed.
- Have only qualified persons install, use, or service this unit.

**ELECTRIC SHOCK HAZARD**

Figure 9-1. Circuit Diagram For 460/575 Volt Models



Item No.	Dia. Mkgs.	Part No.	Description	Quantity
<b>Figure 10-1. Parts Assembly</b>				
1		+224 966	Wrapper	1
		178 551	Insulator, Side Lh	1
		175 256	Insulator, Side Rh	1
2		195 585	Handle	2
3		138 442	Label, Caution Falling Equipment	2
4	HD1	216 178	Transducer, Current 600A	1
	PLG9	130 204	Connector & Pins	1
5		216 554	Bus Bar, Current Sensor	1
6		203 341	Bus Bar, Output Rectifier	4
7		196 355	Insulator, Screw	1
8	D1,2,3,4	201 531	Kit, Diode Power Module	4
9		170 647	Bushing, Snap-In Nyl 1.312 Id X 1.500 Mtg Hole	2
10	R1, C5,6			
	R2, C10,11	232 296	Resistor/Capacitor Assy	2
11	RT1,2	173 632	Thermistor, Ntc 30K Ohm	2
12		185 835	Label, Warning Exploding Parts	2
13		+216 227	Windtunnel, Lh	1
14		182 445	Nut, 1.000npt	1
15	CB1	161 078	Circuit Breaker, Man Reset 1p 7a 250VAC	1
16		+232 189	Panel, Rear	1
17		215 980	Bushing, Strain Relief .709/.984 Id X1.375 Mtg Hole	1
		219 487	Cable, Power 12ft 8Ga 4C	1
18		232 190	Hole Layout, Plate Ident	1
19		196 002	Label, Warning Electric Shock Power Cord	1
20		217 392	Label, Caution Incorrect Voltage Will Damage Unit	1
21		216 355	Resistor, W/Terminals	1
22		212 526	Capacitor, Elctlt 1500 Uf 100 VDC Can 1.40 Dia	1
23	CR1	110 386	Relay, Encl 24VAC Dpdt 5a/120VAC 8pin Flange Mtg	1
24		087 111	Clamp, Capacitor 1.375 Dia Clip	1
25		192 853	Bracket, Mtg Contactor/Capacitor/Pc Board	1
26	PC1	215 697	Circuit Card, Control (480/575)	1
	PLG2	131 056	Connector & Sockets (RC2)	1
	PLG3	130 203	Connector & Sockets (RC3)	1
	PLG4	115 094	Connector & Sockets (RC4)	1
	PLG5	115 091	Connector & Sockets (RC5)	1
	PLG7	115 093	Connector & Sockets (RC7)	1
27	RC10	166 679	Connector & Sockets	1
28	T2	216 236	Transformer, Control (480/575)	1
29		+216 232	Windtunnel, Rh	1
30		153 403	Bushing, Snap-in Nyl .750 Id X 1.000mtg	2
31		025 248	Stand-Off, Insul .250-20 X 1.250 Lg X .437 Thd	4
32		177 547	Bushing, Snap-in Nyl 1.125mtg	1
33		185 214	Bus Bar, Interconnecting	2
34	CT1	175 199	Transformer, Current	1
35	C1,C2	188 446	Capacitor, Polyp Film .5 Uf 900 VAC 10%	2
36	C3,4	193 738	Capacitor, Elctlt 1800uf 500Vdv (480/575)	2
37	PC2	+208 783	Circuit Card, Interconnect (480/575)	1
	PLG13	131 204	Connector & Sockets (RC13)	1
	PLG14,21	115 093	Connector & Sockets (RC14) (RC21)	2
		126 026	Label, Warning Electric Shock	1
38		224 854	Bracket, Di/Dt	1
39		175 482	Coil, Di/Dt	2
40		109 056	Core	2
41	SR1	179 629	Kit Diode, Power Module	1
42	PM1,2	184 258	Kit, Transistor IGBT Module	1
43	L1	173 563	Inductor, Input	1

+When ordering a component originally displaying a precautionary label, the label should also be ordered.

**To maintain the factory original performance of your equipment, use only Manufacturer's Suggested Replacement Parts. Model and serial number required when ordering parts from your local distributor.**

Item No.	Dia. Mkgs.	Part No.	Description	Quantity
----------	------------	----------	-------------	----------

**Figure 10-1. Parts Assembly (Continued)**

44		207 725	Heat Sink, Power Module	1
45	T1	216 229	Transformer, HF (480/575)	1
46		216 529	Heat Sink, Rect	1
47		216 228	Insulator, Rectifier	1
48		173 693	Foot, Mtg Unit	4
49		176 736	Screw, Mtg Foot	4
50		175 132	Base	1
51	PC3	222 689	Circuit Card Assy, Front Panel & Display W/Program	1
	PLG11	115 091	Connector & Sockets (RC2)	1
	PLG18	115 094	Housing Plug+Skts, (Service Kit) (RC5)	1
	PLG17	115 093	Housing Plug+Skts, (Service Kit) (RC4)	1
52	FM	175 084	Motor, Fan 24VDC 3000Rpm	1
53		178 548	Terminal, Connector Friction	2
54	C7,8	222 488	Capacitor Assy,	2
55		232 186	Panel, Front	1
56		129 525	Receptacle, Twlk Insul Fem	2
57	RC1	216 365	Receptacle, W/Leads & Plug	1
		216 592	Nut, Conduit 0.500 Npt 1.135 Od X .180 Thk	1
58		232 188	Nameplate, (Order By Model And Serial Number)	1
59		174 991	Knob, Pointer 1.250	1
60		175 855	Door, Front	1
61		175 138	Box, Louver	1
62		216 527	Label, (Door)	1
63		216 528	Label, Process	1
64		232 747	Switch, W/Leads (Optional)	1
65		176 226	Insulator, Switch Power	1
66	S1	128 756	Switch, Tgl 3pst 40a 600VAC	1
67		134 327	Label, Warning General Precautionary	2
68		199 840	Bus Bar, Diode	4
69		190 125	Label, Warning Electric Shock Power Cord	1
70		224 012	Plate, Rotation Lock	1

+When ordering a component originally displaying a precautionary label, the label should also be ordered.

**To maintain the factory original performance of your equipment, use only Manufacturer's Suggested Replacement Parts. Model and serial number required when ordering parts from your local distributor.**





# SECTION 11 – PARTS LIST FOR STUD GUN

 Hardware is common and not available unless listed.

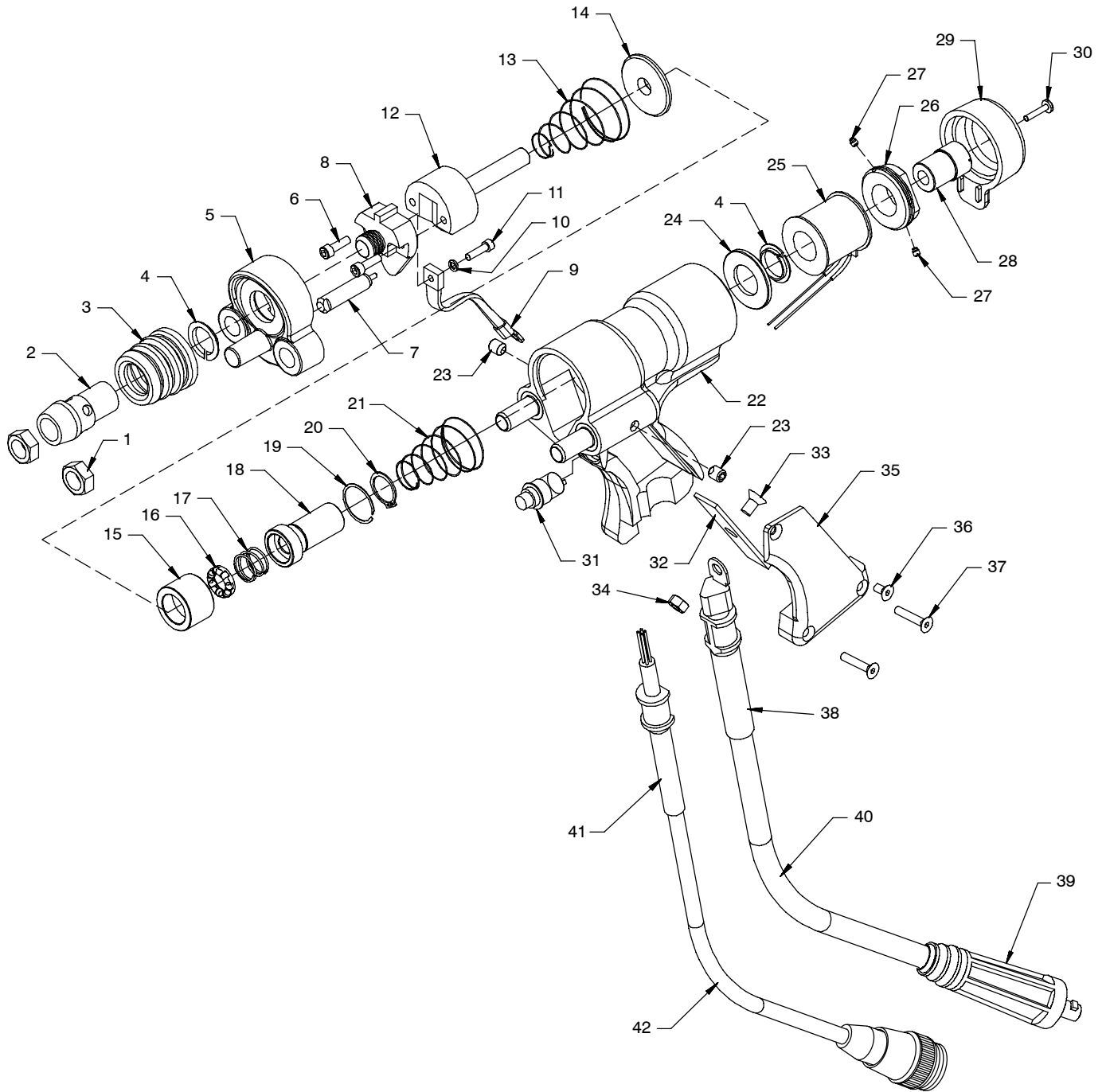

Figure 11-1. Parts Assembly

803 815-A

Item No.	Dia. Mkgs.	Part No.	Description	Quantity
----------	------------	----------	-------------	----------

**Figure 11-1. Parts Assembly**

...	1	217 397	.. Front Cover Jam Nut	2
...	2	217 398	.. Chuck Adapter	1
...	3	217 399	.. Dust Bellows	1
...	4	217 400	.. Nylon Bushing	1
...	5	217 401	.. Front Cover	1
...	6	217 402	.. Cable Clamp Adapter Screw	2
...	7	217 403	.. Plunge Dampener Soft (Standard W/Dampener Model)	1
...	7	217 404	.. Plunge Dampener Medium (Optional)	1
...	7	217 405	.. Plunge Dampener Hard (Optional)	1
...	8	217 406	.. Cable Clamp Adapter	1
...	9	217 407	.. Internal Weld Cable	1
...	10	217 408	.. Internal Weld Cable - Lock Washer	1
...	11	217 409	.. Internal Weld Cable - Screw	1
...	12	217 410	.. Lifting Rod	1
...	13	217 411	.. Main Spring	1
...	14	217 412	.. Lift Release	1
...	15	217 413	.. Moveable Core Bearing Retainer	1
...	16	217 414	.. Lift Bearing	1
...	17	217 415	.. Lift Bearing Spring	1
...	18	217 416	.. Moveable Core Shaft	1
...	19	217 417	.. Shaft Retainer	1
...	20	217 418	.. Shaft Spring Seat	1
...	21	217 419	.. Core Return Spring	1
...	22	217 420	.. Gun Body	1
...	23	217 421	.. Leg Set Screw	2
...	24	217 422	.. Front Coil Yoke	1
...	25	217 423	.. Gun Coil	1
...	26	217 424	.. Rear Coil Yoke	1
...	27	217 425	.. Rear Coil Yoke Set Screws	2
...	28	217 426	.. Adjustable Core	1
...	29	217 427	.. Rear Cap	1
...	30	217 428	.. Rear Cap Screw	1
...	31	217 429	.. Trigger Switch Complete	1
...	32	217 430	.. Weld Cable Anchor Plate	1
...	33	217 431	.. Anchor Plate Screw	1
...	34	217 432	.. Anchor Plate Kep Nut	1
...	35	217 433	.. Handle Cover	1
...	36	217 434	.. Handle Cover - Upper Screw	1
...	37	217 435	.. Handle Cover - Lower Screw	2
...	38	217 436	.. Weld Cable Strain Relief	1
...	39	129 527	.. Male Weld Cable Connector	1
...	40	217 438	.. External Weld Cable Complete 9 ft (2.7 m)	1
...	41	217 439	.. Cable Strain Relief (.280 Dia Yellow Control Wire)	1
...	42	217 440	.. Control Cable (Screw Style) Complete 9 ft (2.7 m)	1

+When ordering a component originally displaying a precautionary label, the label should also be ordered.

**To maintain the factory original performance of your equipment, use only Manufacturer's Suggested Replacement Parts. Model and serial number required when ordering parts from your local distributor.**

# SECTION 12 – OPTIONS AND ACCESSORIES

## 12-1.Plunge Dampener

The plunge dampener controls how fast the melted stud drops into the molten weld pool.

There are three typical dampeners:

- Soft (D rating)
- Medium (E rating)
- Hard (F rating)

Hard dampeners are typically only used for large diameter, extremely heavy studs.

## 12-2.Foot and Leg Setup

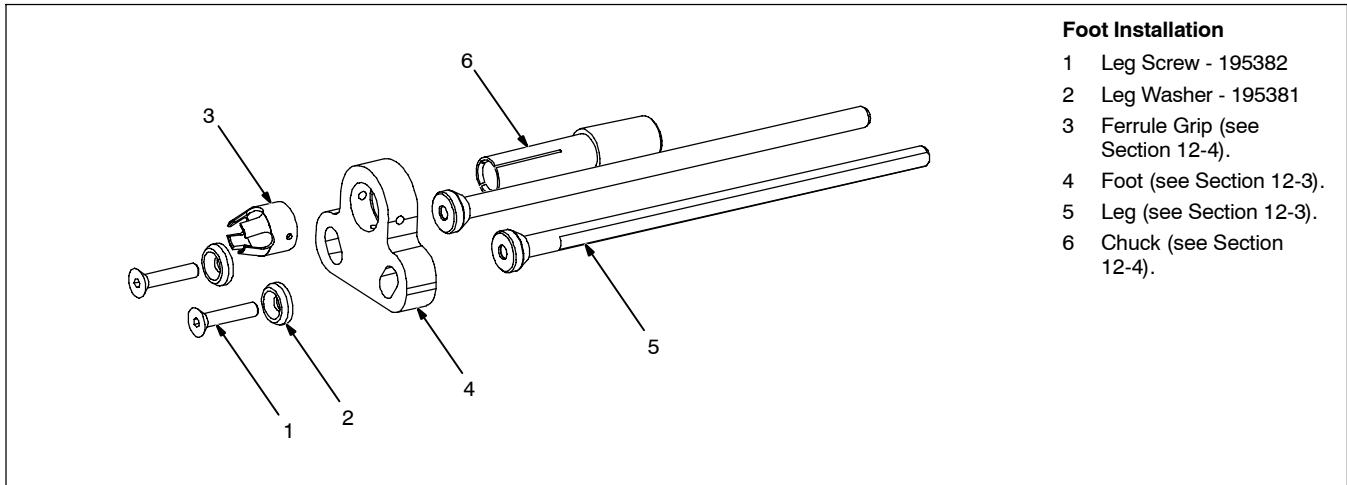

### Foot Installation

- 1 Leg Screw - 195382
- 2 Leg Washer - 195381
- 3 Ferrule Grip (see Section 12-4).
- 4 Foot (see Section 12-3).
- 5 Leg (see Section 12-3).
- 6 Chuck (see Section 12-4).

## 12-3.Table For Foot and Legs

FOOT			LEGS	
Foot Size	Stud Range	Part Number	Length	Part Number
Small	Up to 1/2 Inch	219670	9 Inch	219655
Medium	5/8 to 3/4 Inch	219671	14 Inch	219656

## 12-4.Table For Chucks and Grips

CHUCKS			GRIPS	
Stud Size	Standard Chuck	Long Chuck	Stud Size	Standard Grip
1/4 Inch	219658		1/4 Inch	219664
5/16 Inch	219659		5/16 Inch	219665
3/8 Inch	219660	195371	3/8 Inch	219666
7/16 Inch	219661		7/16 Inch	219667
1/2 Inch	219662		1/2 Inch	219668
5/8 Inch	219663		5/8 Inch	219669

## 12-5.Table For Dampener and Chuck Key

DAMPENER		CHUCK KEY
Rating	Part Number	Part Number
D - Rating (Standard)	217403	219672
E - Rating (Medium)	217404	
F - Rating (Hard)	217405	







# TRUE BLUE<sup>®</sup>

## WARRANTY

Effective January 1, 2007

(Equipment with a serial number preface of "LH" or newer)

This limited warranty supersedes all previous Miller warranties and is exclusive with no other guarantees or warranties expressed or implied.

LIMITED WARRANTY – Subject to the terms and conditions below, Miller Electric Mfg. Co., Appleton, Wisconsin, warrants to its original retail purchaser that new Miller equipment sold after the effective date of this limited warranty is free of defects in material and workmanship at the time it is shipped by Miller. THIS WARRANTY IS EXPRESSLY IN LIEU OF ALL OTHER WARRANTIES, EXPRESS OR IMPLIED, INCLUDING THE WARRANTIES OF MERCHANTABILITY AND FITNESS.

Within the warranty periods listed below, Miller will repair or replace any warranted parts or components that fail due to such defects in material or workmanship. Miller must be notified in writing within thirty (30) days of such defect or failure, at which time Miller will provide instructions on the warranty claim procedures to be followed.

Miller shall honor warranty claims on warranted equipment listed below in the event of such a failure within the warranty time periods. All warranty time periods start on the delivery date of the equipment to the original end-user purchaser, and not to exceed one year after the equipment is shipped to a North American distributor or eighteen months after the equipment is shipped to an International distributor.

- 5 Years Parts — 3 Years Labor
  - \* Original main power rectifiers
- 3 Years — Parts and Labor
  - \* Transformer/Rectifier Power Sources
  - \* Plasma Arc Cutting Power Sources
  - \* Process Controllers
  - \* Semi-Automatic and Automatic Wire Feeders
  - \* Inverter Power Sources (Unless Otherwise Stated)
  - \* Water Coolant Systems (Integrated)
  - \* Intellitig
  - \* Engine Driven Welding Generators  
**(NOTE: Engines are warranted separately by the engine manufacturer.)**
- 1 Year — Parts and Labor Unless Specified
  - \* Motor Driven Guns (w/exception of Spoolmate Spoolguns)
  - \* Positioners and Controllers
  - \* Automatic Motion Devices
  - \* RFCS Foot Controls
  - \* Induction Heating Power Sources, Coolers, and Electronic Controls/Recorders
  - \* Water Coolant Systems (Non-Integrated)
  - \* Flowgauge and Flowmeter Regulators (No Labor)
  - \* HF Units
  - \* Grids
  - \* Spot Welders
  - \* Load Banks
  - \* Arc Stud Power Sources & Arc Stud Guns
  - \* Racks
  - \* Running Gear/Trailers
  - \* Plasma Cutting Torches (except APT & SAF Models)
  - \* Field Options  
(NOTE: Field options are covered under True Blue<sup>®</sup> for the remaining warranty period of the product they are installed in, or for a minimum of one year — whichever is greater.)
  - \* Bernard-Branded Mig Guns (No Labor)
  - \* Weldcraft-Branded TIG Torches (No Labor)
  - \* Subarc Wire Drive Assemblies
- 6 Months — Batteries
- 90 Days — Parts
  - \* MIG Guns/TIG Torches and Subarc (SAW) Guns

- \* Induction Heating Coils and Blankets, Cables, and Non-Electronic Controls
- \* APT & SAF Model Plasma Cutting Torches
- \* Remote Controls
- \* Accessory (Kits)
- \* Replacement Parts (No labor)
- \* Spoolmate Spoolguns
- \* Canvas Covers

Miller's True Blue<sup>®</sup> Limited Warranty shall not apply to:

- Consumable components; such as contact tips, cutting nozzles, contactors, brushes, slip rings, relays or parts that fail due to normal wear. (Exception: brushes, slip rings, and relays are covered on Bobcat, Trailblazer, and Legend models.)**
- Items furnished by Miller, but manufactured by others, such as engines or trade accessories. These items are covered by the manufacturer's warranty, if any.
- Equipment that has been modified by any party other than Miller, or equipment that has been improperly installed, improperly operated or misused based upon industry standards, or equipment which has not had reasonable and necessary maintenance, or equipment which has been used for operation outside of the specifications for the equipment.

MILLER PRODUCTS ARE INTENDED FOR PURCHASE AND USE BY COMMERCIAL/INDUSTRIAL USERS AND PERSONS TRAINED AND EXPERIENCED IN THE USE AND MAINTENANCE OF WELDING EQUIPMENT.

In the event of a warranty claim covered by this warranty, the exclusive remedies shall be, at Miller's option: (1) repair; or (2) replacement; or, where authorized in writing by Miller in appropriate cases, (3) the reasonable cost of repair or replacement at an authorized Miller service station; or (4) payment of or credit for the purchase price (less reasonable depreciation based upon actual use) upon return of the goods at customer's risk and expense. Miller's option of repair or replacement will be F.O.B., Factory at Appleton, Wisconsin, or F.O.B. at a Miller authorized service facility as determined by Miller. Therefore no compensation or reimbursement for transportation costs of any kind will be allowed.

TO THE EXTENT PERMITTED BY LAW, THE REMEDIES PROVIDED HEREIN ARE THE SOLE AND EXCLUSIVE REMEDIES. IN NO EVENT SHALL MILLER BE LIABLE FOR DIRECT, INDIRECT, SPECIAL, INCIDENTAL OR CONSEQUENTIAL DAMAGES (INCLUDING LOSS OF PROFIT), WHETHER BASED ON CONTRACT, TORT OR ANY OTHER LEGAL THEORY.

ANY EXPRESS WARRANTY NOT PROVIDED HEREIN AND ANY IMPLIED WARRANTY, GUARANTY OR REPRESENTATION AS TO PERFORMANCE, AND ANY REMEDY FOR BREACH OF CONTRACT TORT OR ANY OTHER LEGAL THEORY WHICH, BUT FOR THIS PROVISION, MIGHT ARISE BY IMPLICATION, OPERATION OF LAW, CUSTOM OF TRADE OR COURSE OF DEALING, INCLUDING ANY IMPLIED WARRANTY OF MERCHANTABILITY OR FITNESS FOR PARTICULAR PURPOSE, WITH RESPECT TO ANY AND ALL EQUIPMENT FURNISHED BY MILLER IS EXCLUDED AND DISCLAIMED BY MILLER.

Some states in the U.S.A. do not allow limitations of how long an implied warranty lasts, or the exclusion of incidental, indirect, special or consequential damages, so the above limitation or exclusion may not apply to you. This warranty provides specific legal rights, and other rights may be available, but may vary from state to state.

In Canada, legislation in some provinces provides for certain additional warranties or remedies other than as stated herein, and to the extent that they may not be waived, the limitations and exclusions set out above may not apply. This Limited Warranty provides specific legal rights, and other rights may be available, but may vary from province to province.

miller\_warr 2007-01

### Warranty Questions?

Call  
1-800-4-A-MILLER  
for your local  
Miller distributor.

Your distributor also gives  
you ...

### Service

You always get the fast,  
reliable response you  
need. Most replacement  
parts can be in your  
hands in 24 hours.

### Support

Need fast answers to the  
tough welding questions?  
Contact your distributor.  
The expertise of the  
distributor and Miller is  
there to help you, every  
step of the way.





# Owner's Record

Please complete and retain with your personal records.

Model Name

Serial/Style Number

Purchase Date

(Date which equipment was delivered to original customer.)

Distributor

Address

City

State

Zip



## For Service

**Contact a DISTRIBUTOR or SERVICE AGENCY near you.**

Always provide Model Name and Serial/Style Number.

Contact your Distributor for:

Welding Supplies and Consumables

Options and Accessories

Personal Safety Equipment

Service and Repair

Replacement Parts

Training (Schools, Videos, Books)

Technical Manuals (Servicing Information and Parts)

Circuit Diagrams

Welding Process Handbooks

To locate a Distributor or Service Agency visit [www.millerwelds.com](http://www.millerwelds.com) or call 1-800-4-A-Miller

Contact the Delivering Carrier to:

File a claim for loss or damage during shipment.

For assistance in filing or settling claims, contact your distributor and/or equipment manufacturer's Transportation Department.

### Miller Electric Mfg. Co.

An Illinois Tool Works Company  
1635 West Spencer Street  
Appleton, WI 54914 USA

### International Headquarters—USA

USA Phone: 920-735-4505 Auto-Attended  
USA & Canada FAX: 920-735-4134  
International FAX: 920-735-4125

### European Headquarters – United Kingdom

Phone: 44 (0) 1204-593493  
FAX: 44 (0) 1204-598066

[www.MillerWelds.com](http://www.MillerWelds.com)

